



POQUEMA - Ind. e Com. de Móveis Ltda, Rua Urundá, 1400 - Fonefex (43) 3303-3249  
Parque Industrial II - CEP 83703-070 - Arapongas PR - assistencia@poquema.com.br

requisito: COZINHA LOLITA

CÓDIGO : AV17

ASPECTO FINAL

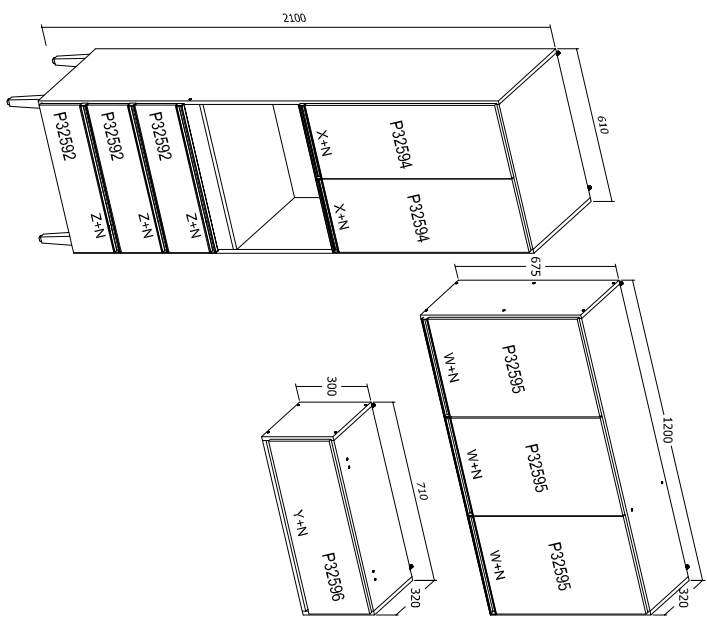

P0	NOME DA PEÇA / NAME OF PARTS	DIMENSÕES	QTD.
P32571	BASE DO PANELEIRO / BASE	578 X 450 X 15MM	1
P32572	VISTA FRONTAL / FRONT VIEW	578 X 80 X 15MM	1
P32573	BASE DA PORTA PANELEIRO / DOOR BASE	578 X 450 X 15MM	1
P32574	TAMPO PANELEIRO / TOP	578 X 450 X 15MM	1
P32575	PRATELEIRA SUP DO PANELEIRO / SUPERIOR SHELVES	578 X 450 X 15MM	1
P32576	CHABEU / TOP	578 X 450 X 15MM	1
P32577	BASE AÉREO / BASE	1166 X 300 X 15MM	1
P32578	PRATELEIRA AÉREO / SHELVES	772 X 300 X 15MM	1
P32579	PRATELEIRA MENOR AÉREO / SMALL SHELVES	379 X 300 X 15MM	1
P32580	CHABEU AÉREO / TOP	1166 X 300 X 15MM	1
P32581	BASE AÉREO GELADEIRA / BASE	680 X 300 X 15MM	1
P32582	CHABEU AÉREO GELADEIRA / TOP	680 X 300 X 15MM	1
P32583	LATERAL DIREITA PANELEIRO / RIGHT SIDE	1935 X 450 X 15MM	1
P32584	LATERAL ESQUERDA PANELEIRO / LEFT SIDE	1935 X 450 X 15MM	1
P32585	LATERAL DIREITA AÉREO / RIGHT SIDE	675 X 300 X 15MM	1
P32586	LATERAL ESQUERDA AÉREO / LEFT SIDE	675 X 300 X 15MM	1
P32587	DIVISÃO DO AÉREO / DIVISION	645 X 300 X 15MM	1
P32588	LATERAL DIREITA DO AÉREO / RIGHT SIDE	300 X 300 X 15MM	1
P32589	LATERAL ESQUERDA DO AÉREO / LEFT SIDE	300 X 300 X 15MM	1
P32590	LATERAL DE GAVETA / DRAWER SIDE	350 X 140 X 15MM	6
P32591	CONTRA FUNDO / DRAWER BACK	523 X 130 X 15MM	3
P32592	FRENTE DE GAVETA / DRAWER FRONT	588 X 172 X 15MM	3
P32594	PORTA PANELEIRO / DOOR	800 X 293 X 15MM	2
P32595	PORTA AÉREO / DOOR	630 X 390 X 15MM	3
P32596	PORTA AÉREO GELADEIRA / DOOR	690 X 255 X 15MM	1
P32597	FUNDO PANELEIRO / BACK	603 X 337 X 03MM	2
P32598	FUNDO CENTRAL PANELEIRO / CENTRAL BACK	603 X 415 X 03MM	1
P32599	FUNDO DIREITO AÉREO / LEFT BACK	670 X 399 X 03MM	1
P32600	FUNDO SUPERIOR AÉREO / SUPERIOR BACK	791 X 335 X 03MM	2
P32601	FUNDO AÉREO GELADEIRA / BACK	705 X 295 X 03MM	1
P32602	FUNDO DE GAVETA / DRAWER BACK	533 X 355 X 03MM	3
P32603	FUNDO PANELEIRO SUPERIOR / SUPERIOR BACK	603 X 415 X 03MM	2

1º PASSO - PREPARAÇÃO DAS PEGAS  
1º STEP - PARTS PREPARATION

LISTA DE ACESSÓRIOS / LIST OF ACCESSORIES	QTD.	IMAGEM
A PARA-FUSO / SCREW M4X25MM	4	
B PORCA / NUT M4	4	
C CAPA FIXADOR L / FIXER L	6	
D PARA-FUSO / SCREW 5.5X50MM	6	
E PREGO / NAIL 08 X 08MM	120	
F CALÇO DOBRADIÇA / SHIM OF HINGE	12	
G DOBRADIÇA / METAL HINGE	12	
H UNIÃO DE FUNDO / UNION BACK	20	
I CANTONEIRA / METAL CONNECTION	12	
J CAVILHA / PLUG 6X30MM	12	
K LOGOMARCA / TAG	1	
L FIXADOR L / FIXER L	6	
M BUCHA / PLASTIC ANCHOR 8MM	6	
N PARA-FUSO / SCREW 3.5X12MM	150	
O PARA-FUSO / SCREW 4.5X40MM	4	
P PARA-FUSO / SCREW 4.0X50MM	64	
Q PARA-FUSO DE UNIÃO / UNION SCREW	4	
R COLA / GLUE	1	
S PISTÃO A GAS 50N / GAS PISTON	2	
U TRILHO TELESCÓPICO / METAL SLIDE	3	
V PÉ / FOOT	4	
X PUXADOR PERFIL / HANDLE 292MM	2	
Z PUXADOR PERFIL / HANDLE 588MM	3	
W PUXADOR PERFIL / HANDLE 390MM	3	
Y PUXADOR PERFIL / HANDLE 690MM	1	

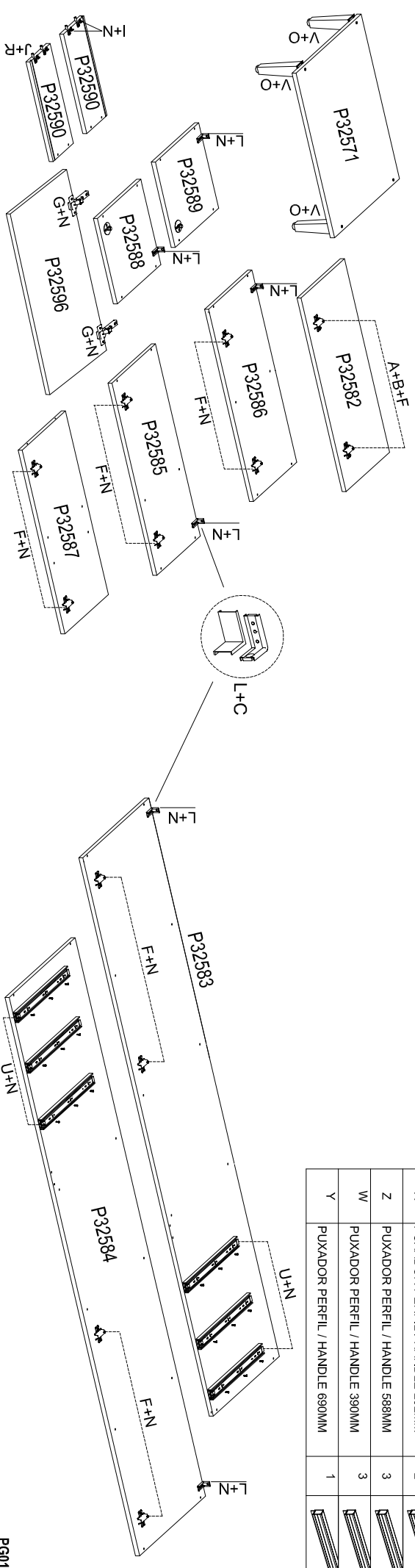

**2º PASSO - MONTAGEM PANELEIRO**  
STEP - KITCHEN ASSEMBLY

L+O+N+D

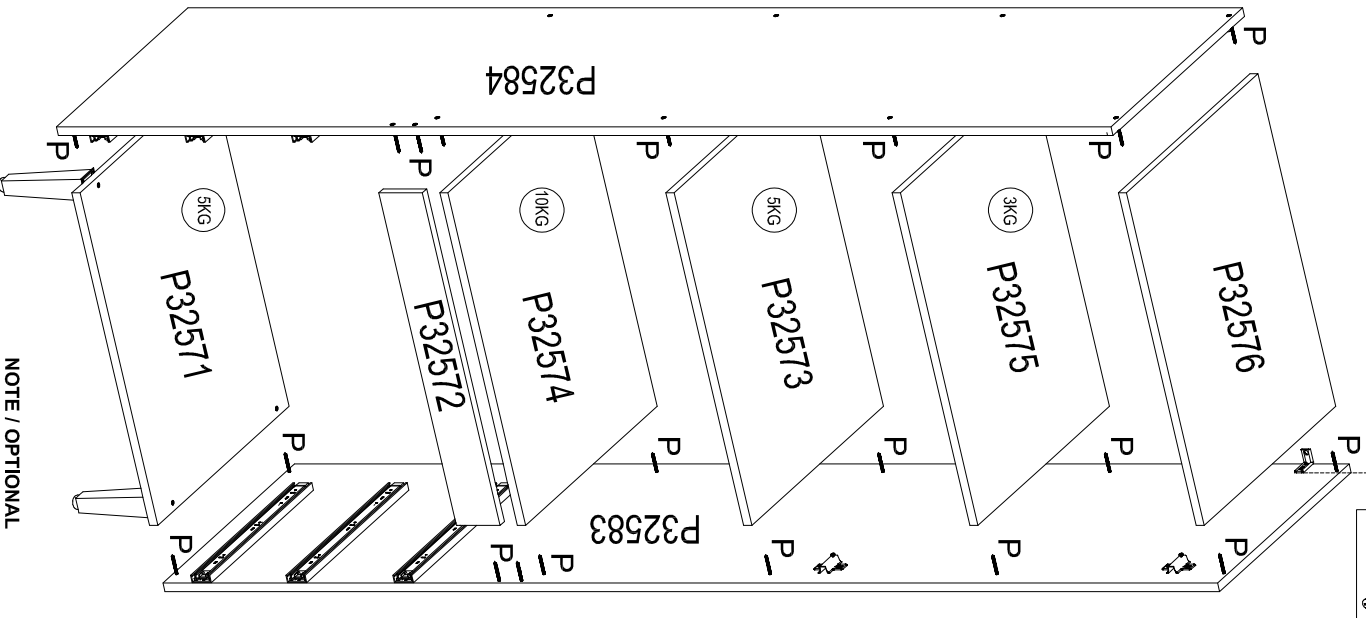

**PESO TOTAL SUPOSTADO 40KG**  
**WEIGHT SUPPORTED**

**NOTE / OPTIONAL**  
To join two modules use union screw, drill side with 6mm through drill.

**3º PASSO - MONTAGEM PANELEIRO**  
STEP - KITCHEN ASSEMBLY

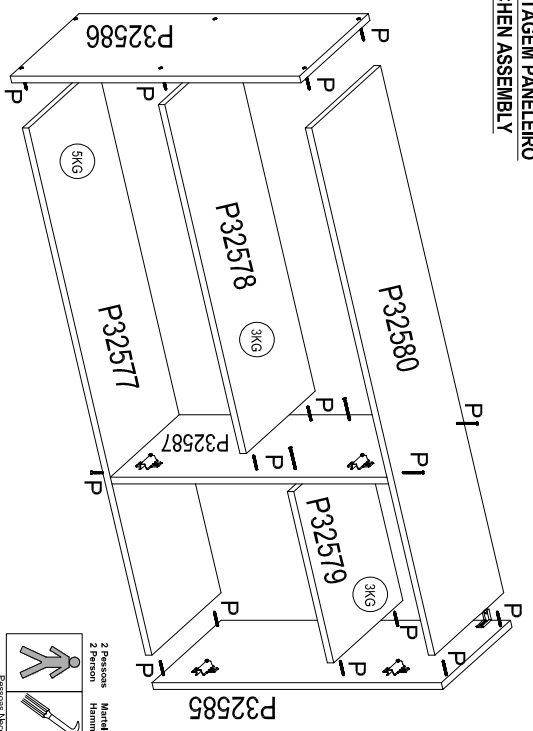

- 2 Pessoas: Martelo Parafusadeira Chave Phillips  
2 Person: Hammer Screwdriver Key Phillips  
Pessoas Necessárias para montagem: People required for assembly
- 

**4º PASSO - MONTAGEM PANELEIRO**  
STEP - KITCHEN ASSEMBLY

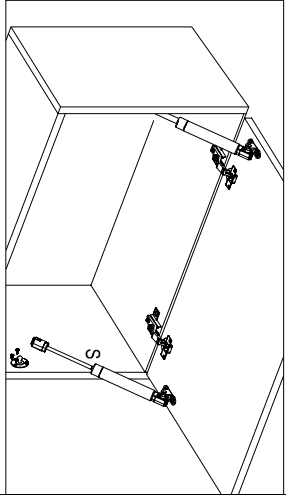
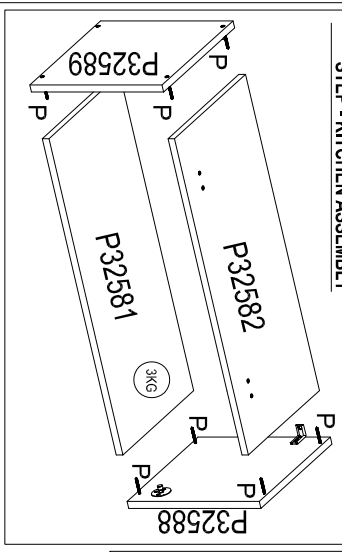

**MONTAGEM PORTA BASCULANTE COM PISTÃO A GÁS**  
**ASSEMBLY GAS PISTON WITH INCLINABLE DOOR**

**5º PASSO - PREGAR OS FUNDOS**  
STEP - KITCHEN ASSEMBLY

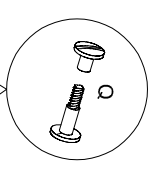

**OBSERVAÇÃO / OPCIONAL**  
Para unir dois módulos usar parafuso de união, furar lateral com broca 6mm passante.

Furar a parede com broca 8mm para inserção da bucha 8mm.

Drill the wall with drill 8mm for insertion of the 8mm bushing.

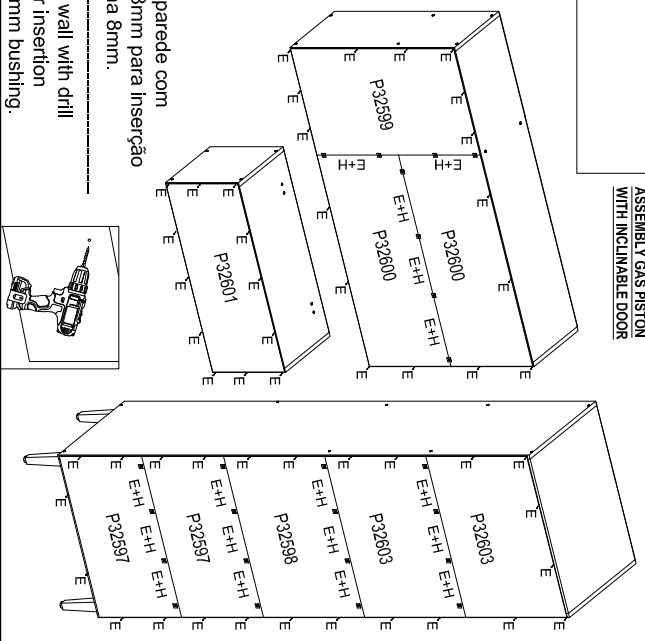

**MONTAGEM DE UMA GAVETA**  
DRAWER ASSEMBLY

**USAR COLA NAS CAVILHAS**  
**USE GLUE ON THE PLUG**

