

HENNInd. e Com. de Móveis Henn
Mondai - SC - Brasil

☎ +55 49 3674.3500

📷 @moveishenn
www.henn.com.br**INSTRUÇÕES DE
MONTAGEM**INSTRUCCIONES DE MONTAJE
ASSEMBLY INSTRUCTIONS**Roupeiro Casinha 3 Portas 2 Gavetas**

| Armario Casa 3 Puertas 2 Cajones | Wardrobe House 3 Doors 2 Drawers

I123-18 Rústico/Branco Brilho

I123-165 Rústico/Rosa Chá

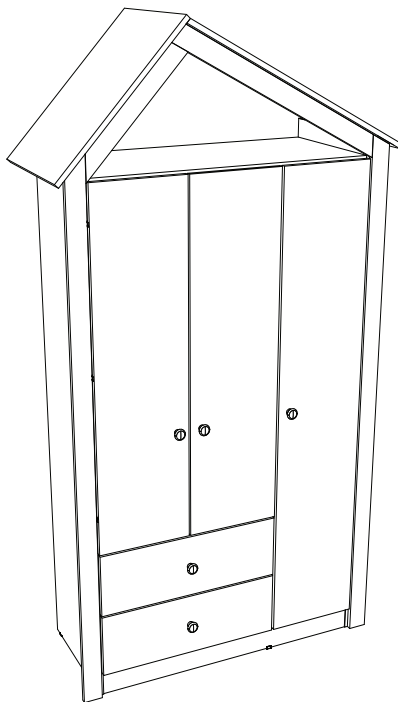
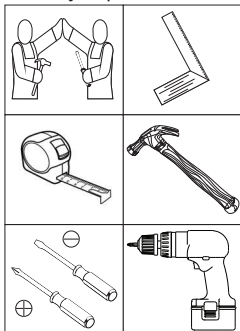
**Requisitos para montagem**
Requisitos para la montaje
Assembly Requirements

Imagens meramente ilustrativas,
não acompanha o produto.
Imágenes ilustrativas, no incluidas
con el producto.
Illustrative images, not included
with the product.

ASSISTÊNCIA TÉCNICA

Para solicitação de Assistência Técnica você consumidor deverá entrar em contato com o Lojista o qual você realizou a compra deste produto e solicitar a assistência técnica das peças avariadas. A garantia abrange todas as peças, partes e componentes que eventualmente venham apresentar defeito de fabricação no prazo de 03 (três) meses, contando a partir da entrega do produto ao consumidor, mediante nota fiscal de compra.

AVISO

Para limpeza de seu móvel, use uma flanela seca ou umedecida, e não utilize produtos químicos que possam danificar seu produto.

SISTEMA DE MONTAGEM

O sistema de montagem dos produtos, funciona de acordo com a ordem crescente dos números indicados no desenho. Ex: 01, 02, 03, 04... até a conclusão da montagem.

ADVERTENCIA

Para limpieza de su móvil, use una franela seca o húmeda, y no utilice productos químicos que puedan dañar su producto.

SISTEMA DE MONTAJE

El sistema de montaje de los productos funciona de acuerdo con el orden creciente de los números indicados en el dibujo. Ej.: 01, 02, 03, 04... hasta la conclusión del montaje.

NOTICE

To clean your furniture, use a dry or wet cloth, and do not use chemicals that may damage your product.

ASSEMBLY SYSTEM

The products' assembly system works according to the increasing order of the indicated numbers. For example: 01, 02, 03, 04 ... to the end of the assembly.

ACESSÓRIOS | ACCESORIOS | ACCESSORIES

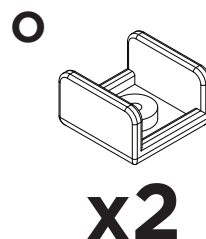
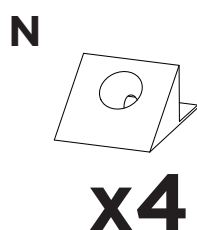
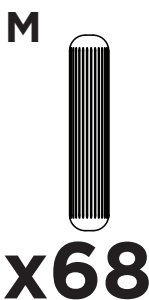
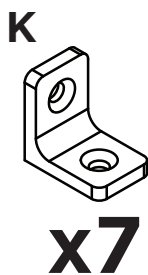
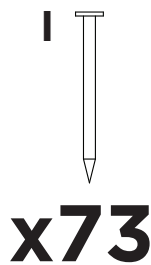
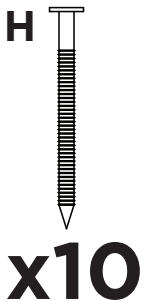
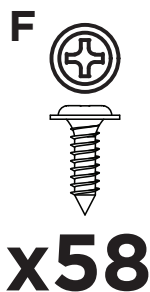
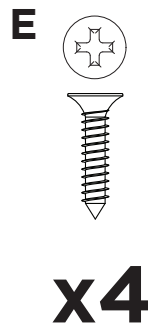
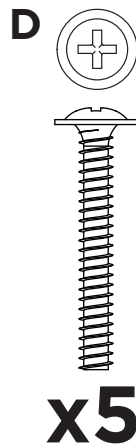
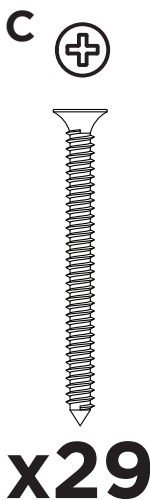
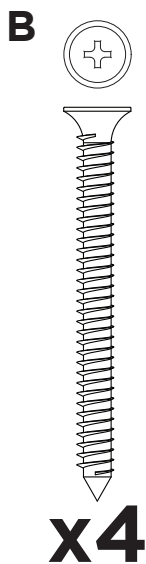
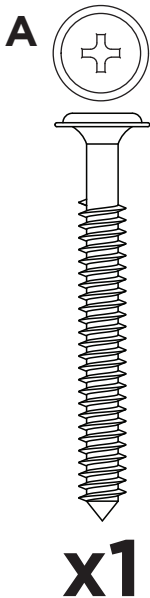

Parafusos em escala
Tornillos escalados
Scaled screws **1:1**

ACESSÓRIOS | ACCESORIOS | ACCESSORIES

P

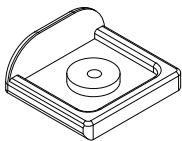
**x4**

Q

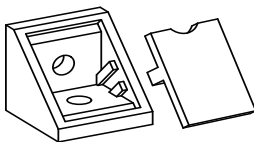
**x8**

R

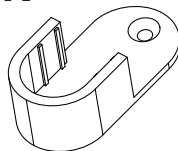
**x2**

S

**x5**

T

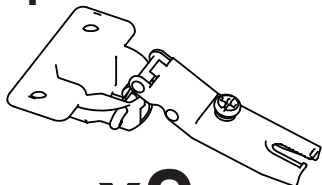
**x9**

U

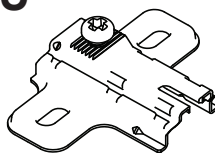
**x9**

V

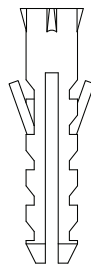
**x1**

W

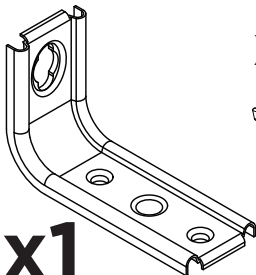
**x1**

X

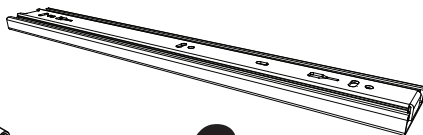
**x2**

Y

**x1**

Z

**x1**

AA

**x1**

AB

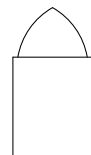
**x3**

AC

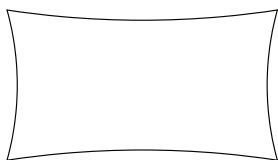
**x1**

AD

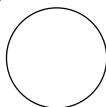
**x30**

AE

**x1**

LISTA DE PEÇAS | LISTA DE PIEZAS | LIST OF PIECES

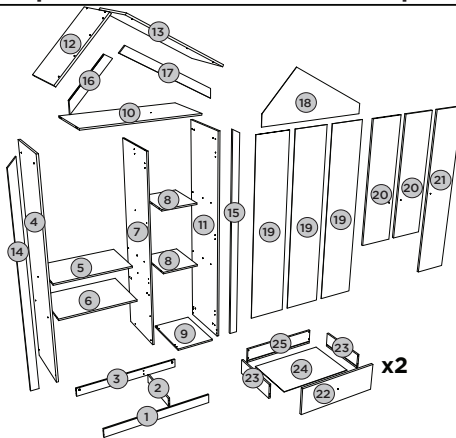

Item	Caixa Caja Box	Qty Ctd Qty	Descrição Descripción Description	Dimensões (mm) Dimensiones (mm) Dimensions (mm)		
				Comprimento Largo Length	Largura Ancho Width	Espessura Grosor Thickness
1	2/2	01	RODAPÉ FRONTAL PIE DE PÁGINA FRONTAL FRONT FOOTER	885	73	12
2	2/2	01	TRAVESSA DO RODAPÉ BARRA TRANSVERSAL DE PIE DE PÁGINA FOOTER CROSSBAR	380	73	12
3	2/2	01	RODAPÉ TRASEIRO PATÍN TRASERO BACK SKATEBOARD	885	73	12
4	1/2	01	LATERAL ESQUERDA LADO IZQUIERDO LEFT SIDE	1662	410	15
5	2/2	01	PRATELEIRA MAIOR ESTANTE MÁS GRANDE LARGER SHELF	584	350	12
6	2/2	01	TAMPO DAS GAVETAS TAPA DE LOS CAJONES TOP OF DRAWERS	584	410	12
7	1/2	01	DIVISÃO DIVISIÓN DIVISION	1493	410	12
8	2/2	02	PRATELEIRA ESTANTE SHELF	289	350	12
9	2/2	01	BASE BASE BASE	301	410	12
10	2/2	01	TAMPO TAPA TOP	885	410	12
11	1/2	01	LATERAL DIREITA LADO DERECHO RIGHT SIDE	1650	410	15
12	2/2	01	TAMPO MENOR PEQUENA TAPA SMALL TOP	563	445	15
13	2/2	01	TAMPO MAIOR TOP MÁS GRANDE TOP BIGGER	791	445	15
14	1/2	01	MOLDURA LATERAL ESQUERDA MARCO DEL LADO IZQUIERDO LEFT SIDE FRAME	1667	60	15
15	1/2	01	MOLDURA LATERAL DIREITA MARCO DEL LADO DERECHO RIGHT SIDE FRAME	1652	60	15
16	1/2	01	MOLDURA SUPERIOR MENOR MARCO SUPERIOR PEQUEÑO SMALL TOP FRAME	443	60	15
17	1/2	01	MOLDURA SUPERIOR MAIOR MARCO SUPERIOR MÁS GRANDE LARGER TOP FRAME	745	60	15
18	1/2	01	FUNDO SUPERIOR PARTE SUPERIOR INFERIOR UPPER BOTTOM	914	411	3
19	1/2	03	FUNDO FONDO BACKGROUND	1511	300	3
20	1/2	02	PORTA MENOR PUERTA MÁS PEQUEÑA SMALLER DOOR	1097	295	15
21	1/2	01	PORTA PUERTA DOOR	1505	295	15
22	2/2	02	FRENTE DE GAVETA FRENTE DEL CAJÓN DRAWER FRONT	592	200	15
23	2/2	04	LADO DE GAVETA LATERAL DEL CAJÓN DRAWER SIDE	350	110	12
24	2/2	02	FUNDO DE GAVETA FONDO DEL CAJÓN DRAWER BOTTOM	551	361	3
25	2/2	02	RIPA DE TRÁS TRAVESAÑO TRASERO REAR CLAPBOARD	564	110	12







PASSO 1

ITM/I123-

PEÇAS REQUERIDAS

1	RODAPÉ FRONTAL	x1
2	TRAVESSA DO RODAPÉ	x1
3	RODAPÉ TRASEIRO	x1

ACESSÓRIOS REQUERIDOS

F		02
H		02
K		02
L		04
M		08
O		02

FERRAMENTAS NECESSÁRIAS

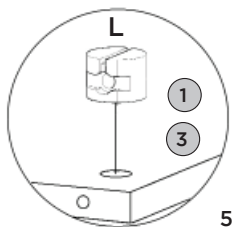
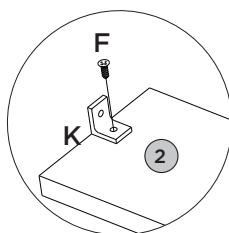
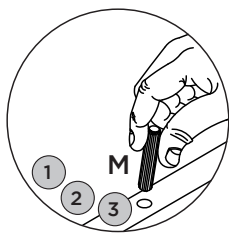
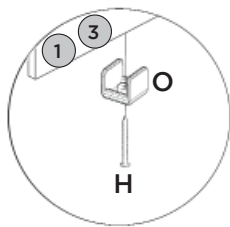
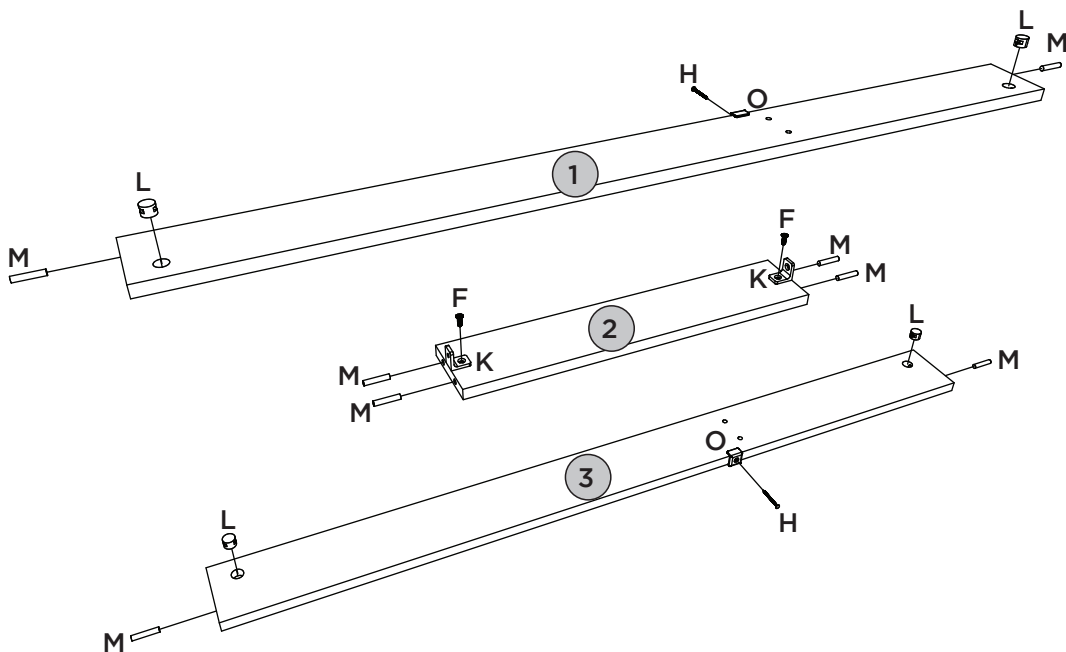
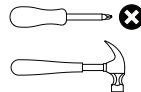

PEÇAS REQUERIDAS

4	LATERAL ESQUERDA	x1
5	PRATELEIRA MAIOR	x1
6	TAMPO DAS GAVETAS	x1

ACESSÓRIOS REQUERIDOS

F		06
G		08
H		02
M		08
P		02
R		01
U		03
X		02

FERRAMENTAS NECESSÁRIAS

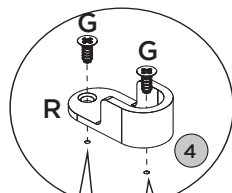
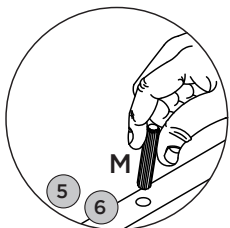
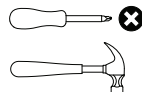

Observe:
Furos
pré-marcados

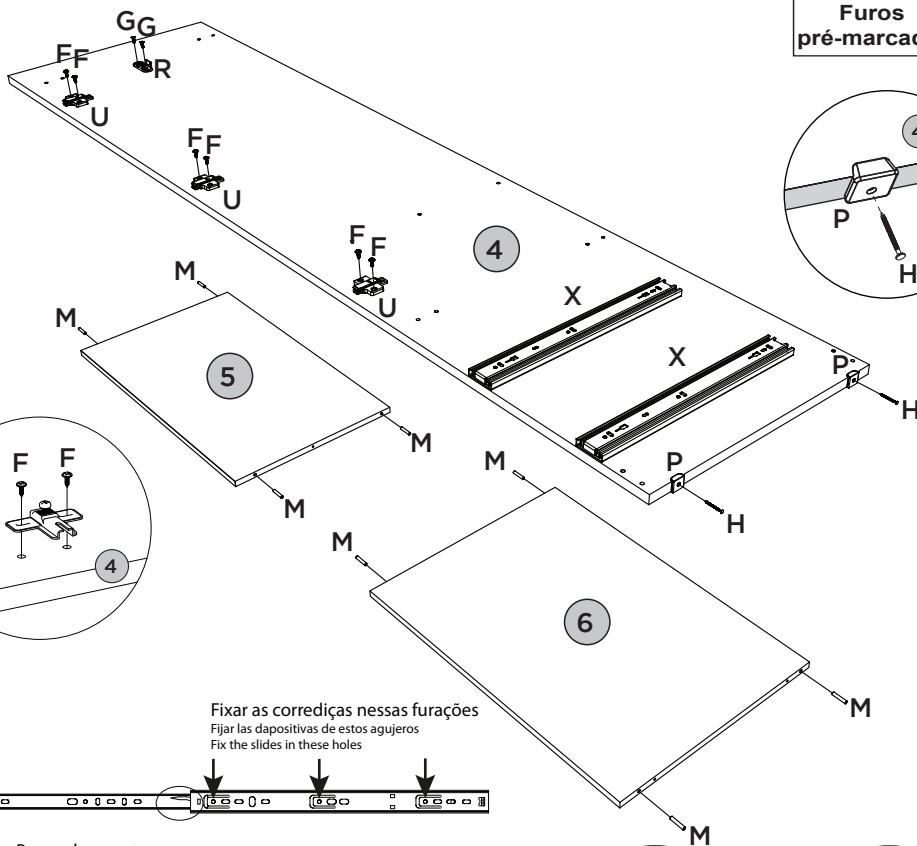
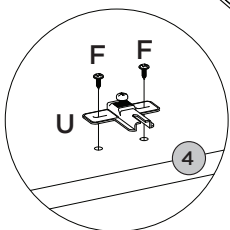
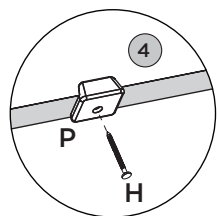

Fixar as correijas nessas furações
Fijar las dispositivos de estos agujeros
Fix the slides in these holes

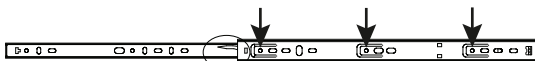

Para a desmontagem
da correija, siga a
instrução ao lado

Para el desmontaje
de la dispositivo, siga las
instrucción en el lado
For disassembly
of the slide, follow the
instruction on the side

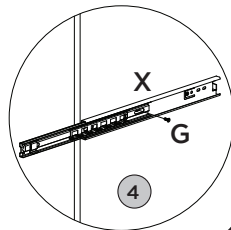
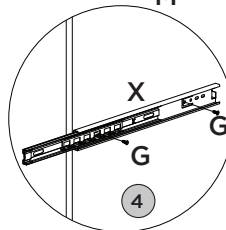
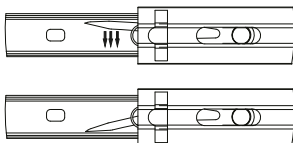







PASSO 3

ITM/I123-

PEÇAS REQUERIDAS

7	DIVISÃO	x1
8	PRATELEIRA	x2
9	BASE	x1

ACESSÓRIOS REQUERIDOS

F		06
G		08
M		14
R		01
U		03
X		02

FERRAMENTAS NECESSÁRIAS

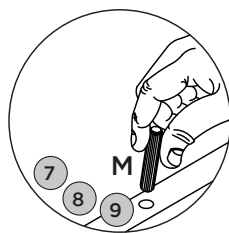
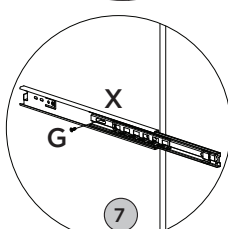
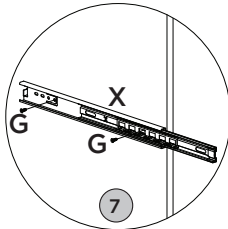
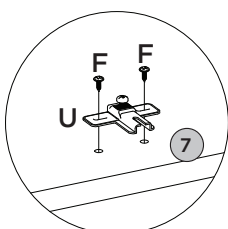
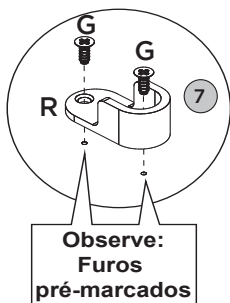
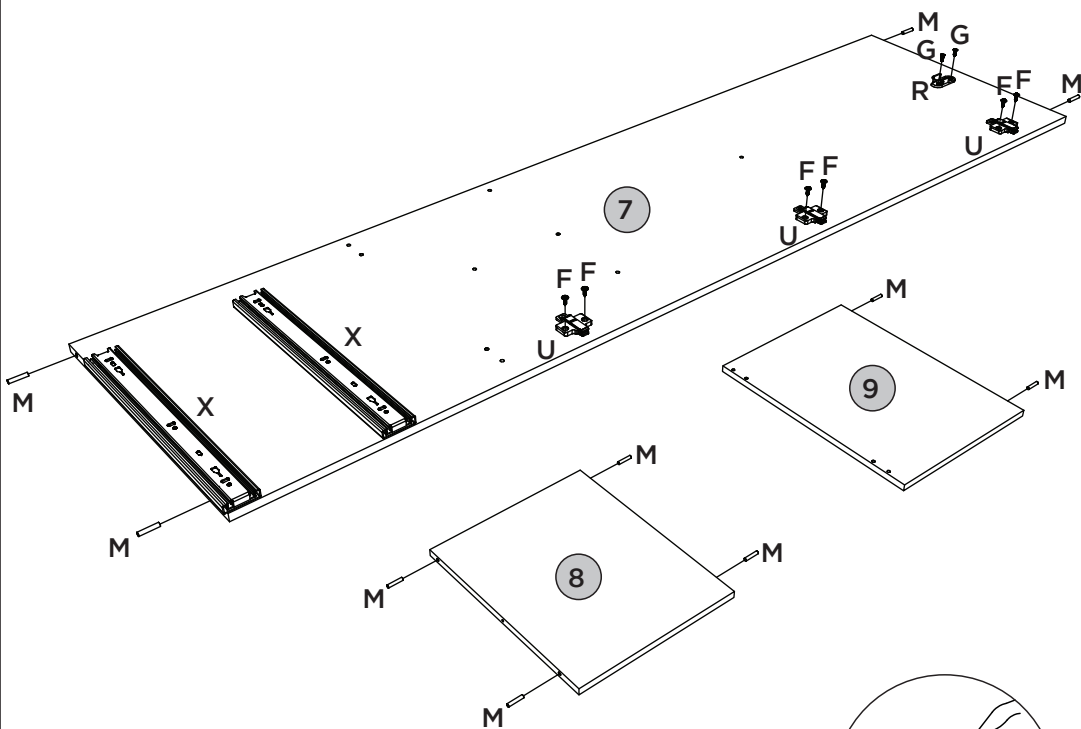
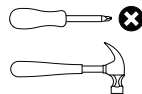





PASSO 4

ITM/1123-

PEÇAS REQUERIDAS

10	TAMPO	x1
11	LATERAL DIREITA	x1

ACESSÓRIOS REQUERIDOS

F		06
H		02
M		04
P		02
U		03

FERRAMENTAS NECESSÁRIAS

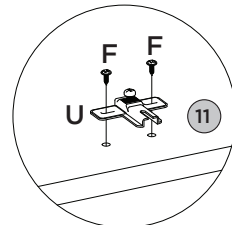
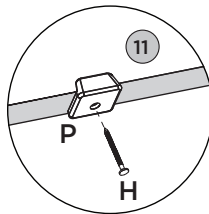
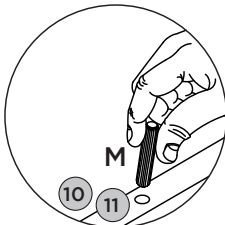
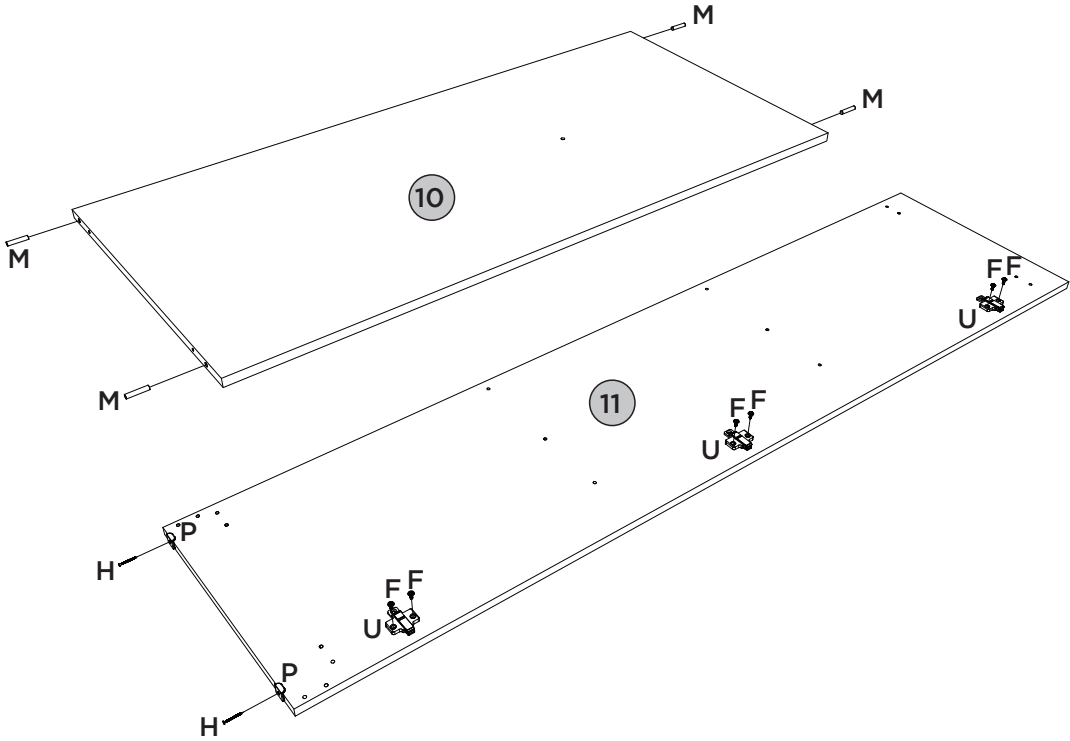
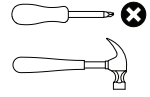

PASSO 5

ITM/I123-

PEÇAS REQUERIDAS

1	RODAPÉ FRONTAL	x1
2	TRAVESSA DO RODAPÉ	x1
3	RODAPÉ TRASEIRO	x1

ACESSÓRIOS REQUERIDOS

F		02
---	---	----

FERRAMENTAS NECESSÁRIAS

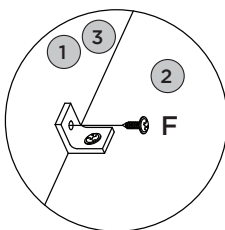
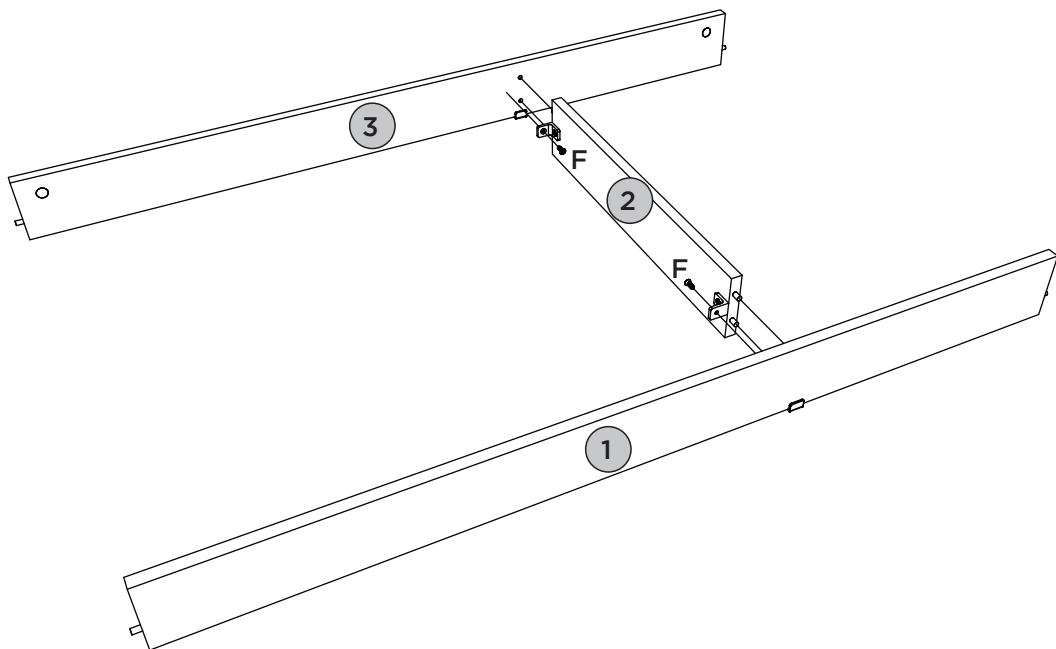
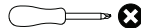



PASSO 6

ITM/1123-

PEÇAS REQUERIDAS

4	LATERAL ESQUERDA	x1
5	PRATELEIRA MAIOR	x1
6	TAMPO DAS GAVETAS	x1

ACESSÓRIOS REQUERIDOS

B		02
C		03

FERRAMENTAS NECESSÁRIAS

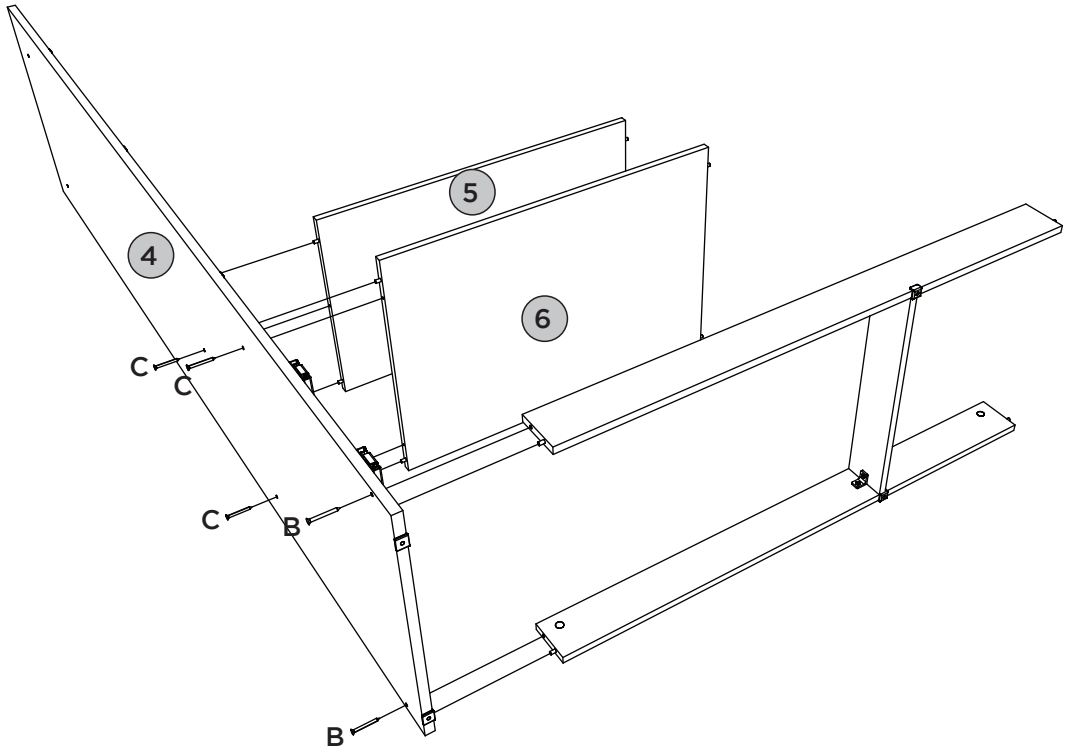
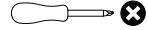

PASSO 7**PEÇAS REQUERIDAS**

7	DIVISÃO	x1
8	PRATELEIRA	x2
9	BASE	x1
10	TAMPO	x1

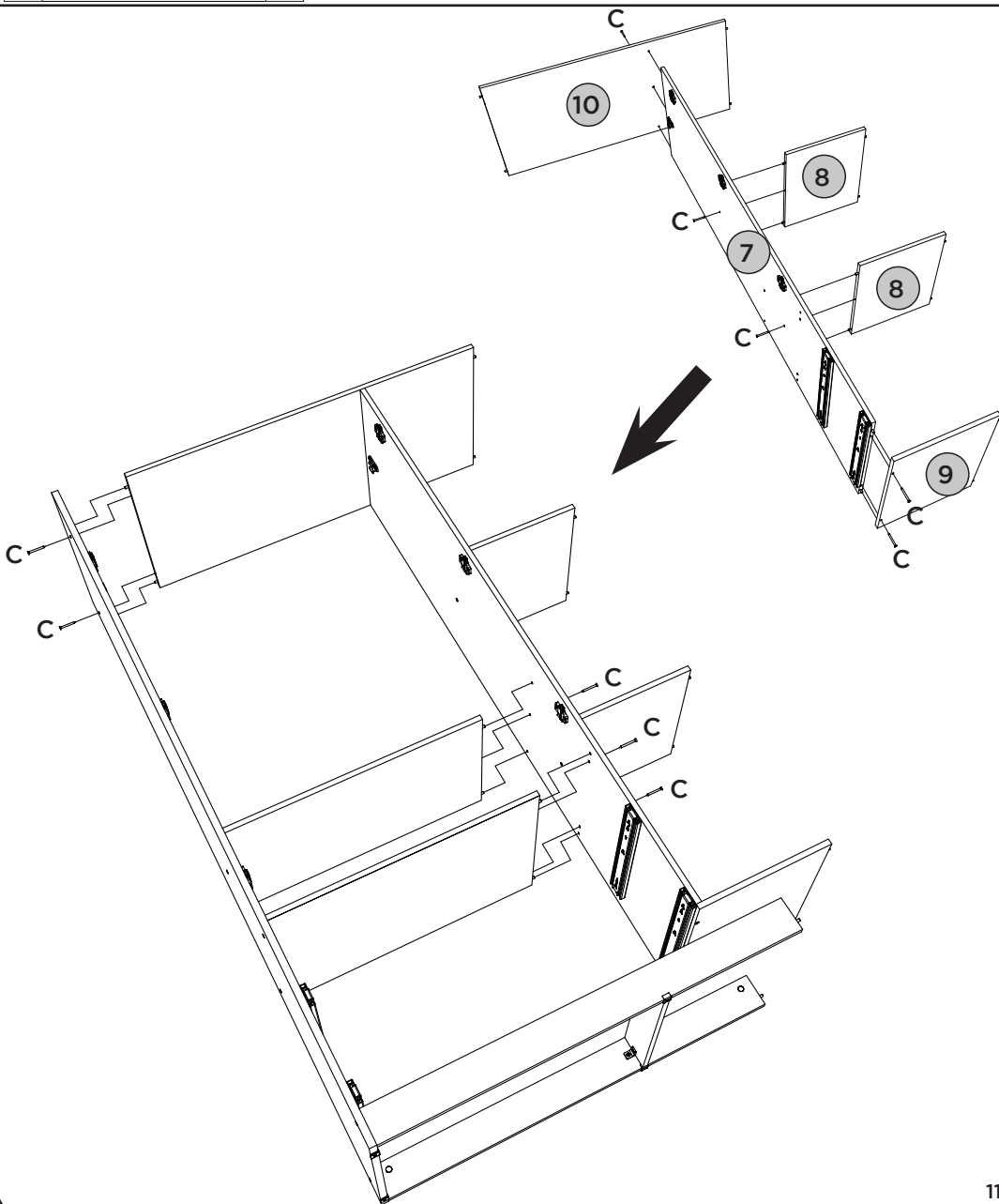
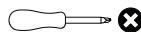
ACESSÓRIOS REQUERIDOS**FERRAMENTAS NECESSÁRIAS**

PASSO 8

PEÇAS REQUERIDAS

11	LATERAL DIREITA	x1
19	FUNDO	X3

ACESSÓRIOS REQUERIDOS

B		02
C		06
F		02
I		57
J		12
K		01
Y		01
Z		01



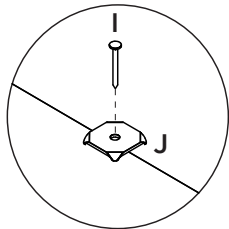
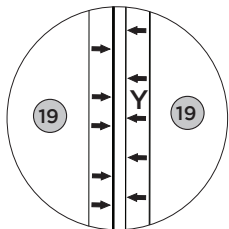
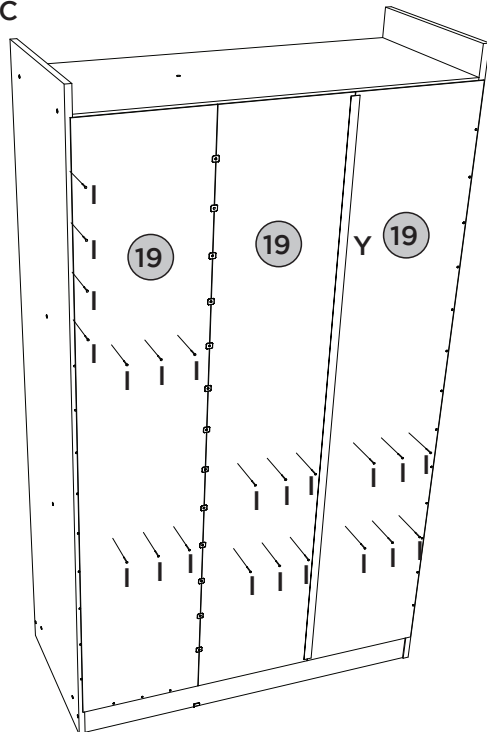
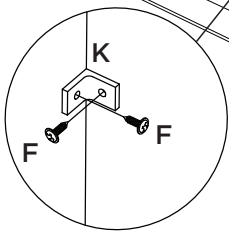
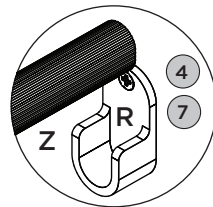
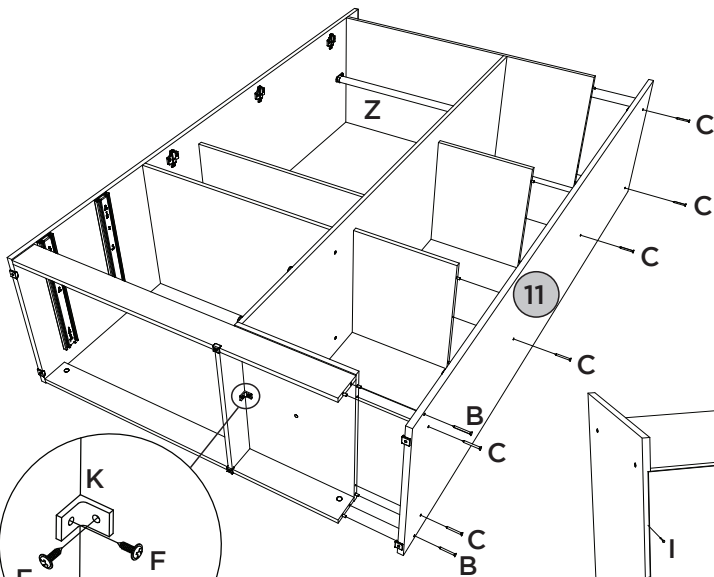
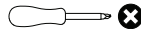

FERRAMENTAS NECESSÁRIAS



PEÇAS REQUERIDAS

12	TAMPO MENOR	x1
13	TAMPO MAIOR	x1
16	MOLDURA SUPERIOR MENOR	x1
17	MOLDURA SUPERIOR MAIOR	x1

ACESSÓRIOS REQUERIDOS

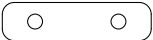
C			08
G			02
AA			01

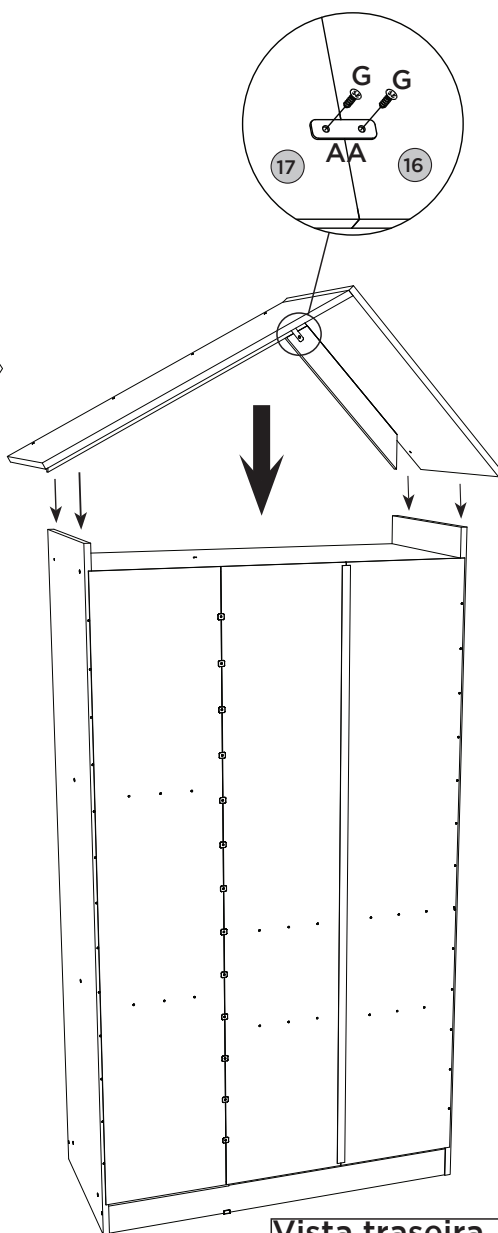
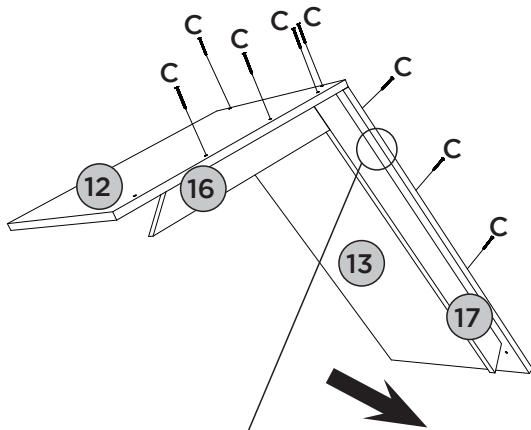
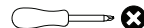
FERRAMENTAS NECESSÁRIAS

Molduras (16 e 17) ficam 20mm para dentro das bordas dos tampos (12 e 13)







Los marcos (16 y 17) estaban a 20 mm dentro de los bordes de las tapas (12 y 13)

Frames (16 and 17) were 20mm inside the edges of the tops (12 and 13)

PEÇAS REQUERIDAS

14	MOLDURA LATERAL ESQUERDA	x1
15	MOLDURA LATERAL DIREITA	x1

ACESSÓRIOS REQUERIDOS

C			02
F			16
Q			08

FERRAMENTAS NECESSÁRIAS

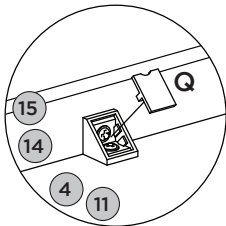
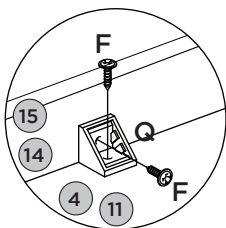
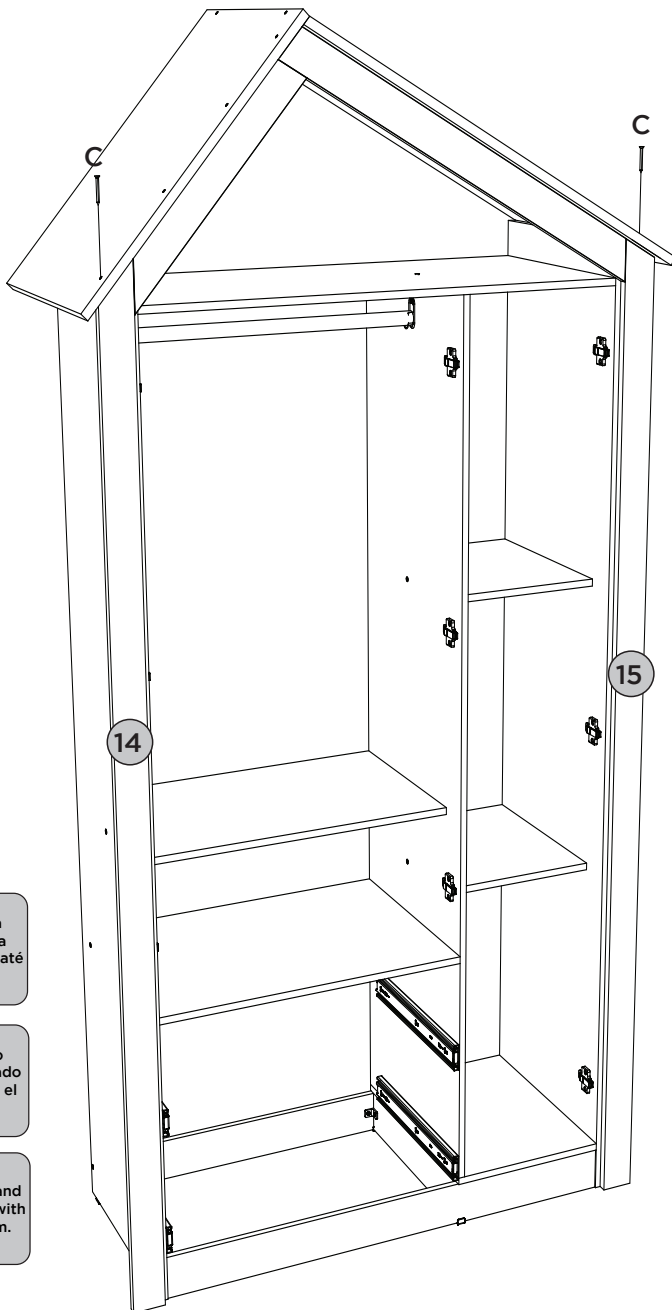

Após colocação do telhado parafusar moldura lateral (14 e 15) 2mm sobre a borda da frente da lateral alinhada com a mesma. Medida da borda até a moldura deverá ser de 58mm.



Después de colocar el techo, atornille el marco lateral (14 y 15) 2mm sobre el borde frontal del lado alineado con él. La medida desde el borde hasta el marco debe ser de 58 mm.

After placing the roof, screw the side frame (14 and 15) 2mm over the front edge of the side aligned with it. Measure from edge to frame should be 58mm.

PEÇAS REQUERIDAS

18	FUNDO SUPERIOR	x1
----	----------------	----

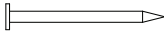
ACESSÓRIOS REQUERIDOS

I		16
J		06

FERRAMENTAS NECESSÁRIAS

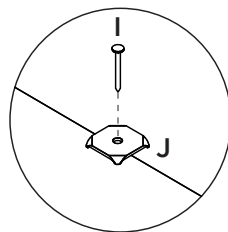
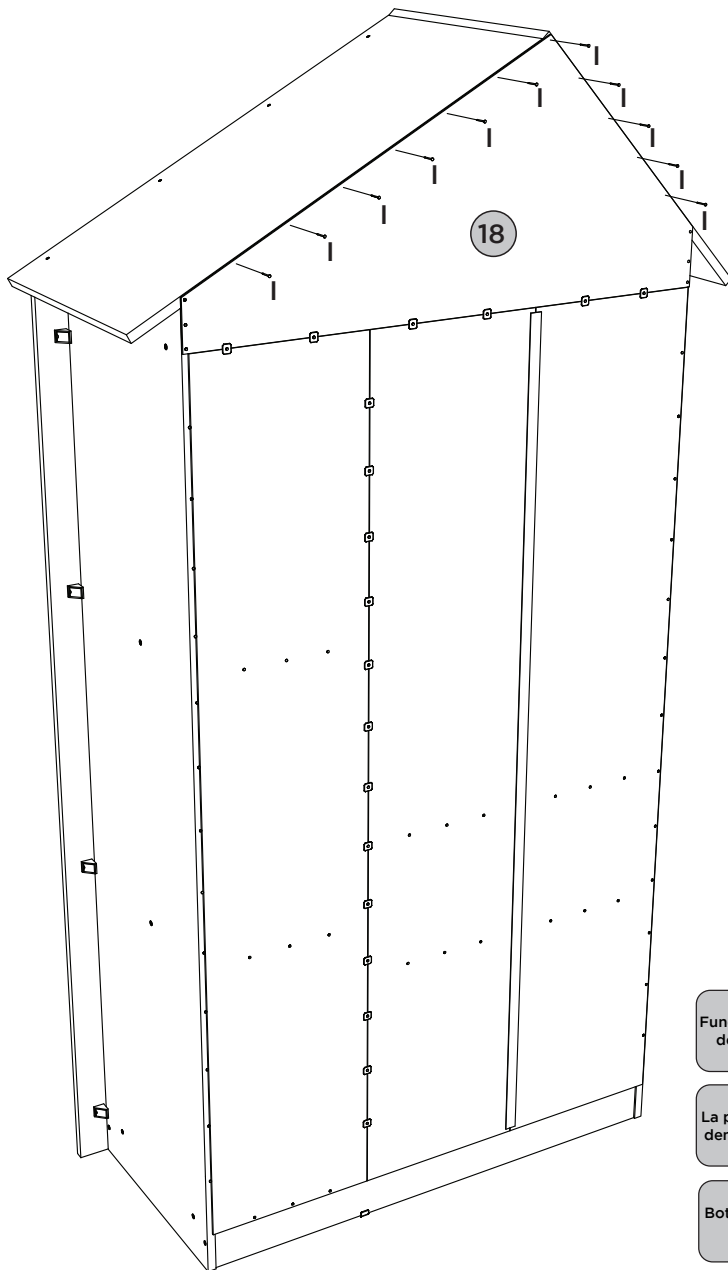
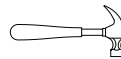

Fundo (18) deverá ser colocado 3mm para dentro das bordas do tampo (12 e 13).

La parte inferior (18) debe colocarse 3mm dentro de los bordes superiores (12 y 13).

Bottom (18) should be placed 3mm inside the top edges (12 and 13).





PASSO 12

ITM/1123-

PEÇAS REQUERIDAS

20	PORTA MEMOR	x2
21	PORTA	x1

ACESSÓRIOS REQUERIDOS

D		03
F		18
S		03
T		09

FERRAMENTAS NECESSÁRIAS

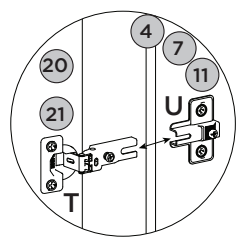
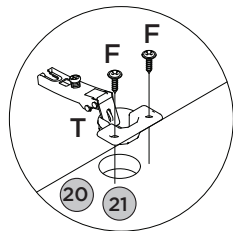
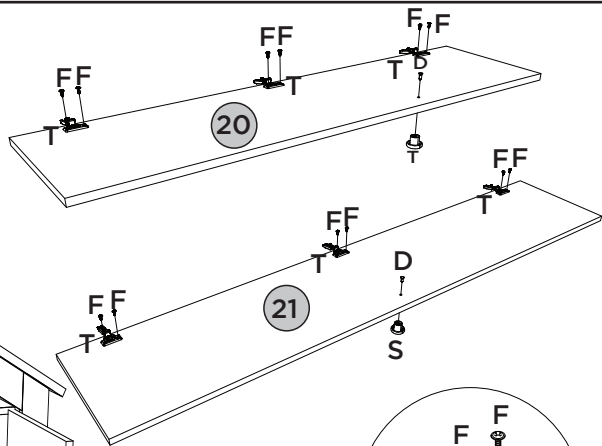
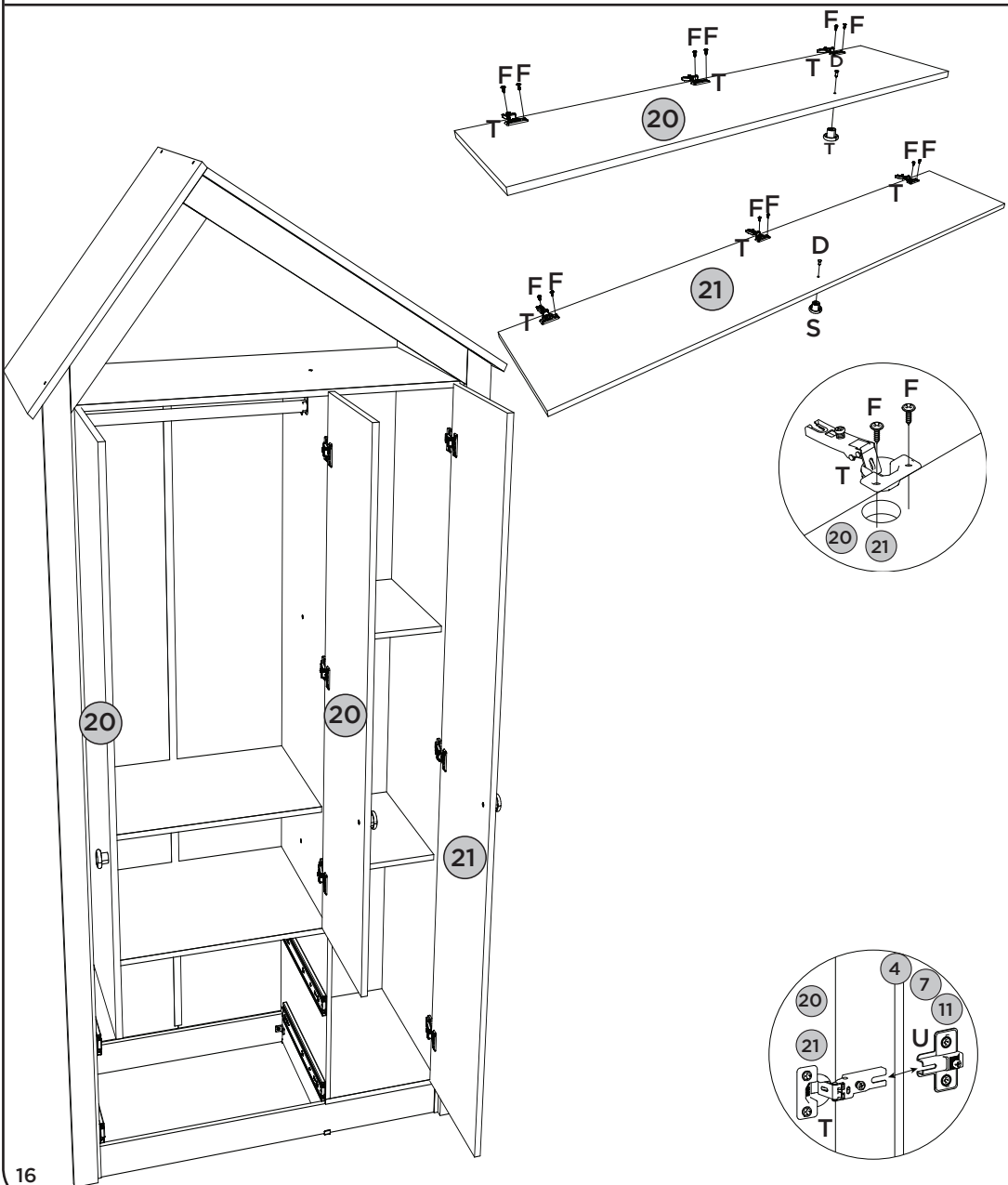
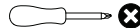

PEÇAS REQUERIDAS

22	FRENTE DE GAVETA	x2
23	LADO DE GAVETA	x4
24	FUNDO DE GAVETA	x2
25	RIPA DE TRAS	x2

ACESSÓRIOS REQUERIDOS

D		02
G		08
H		04
K		04
M		16
S		02
AC		

FERRAMENTAS NECESSÁRIAS

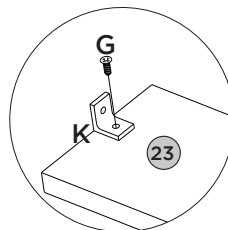
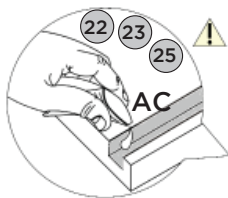
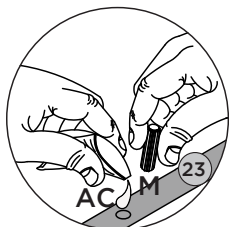
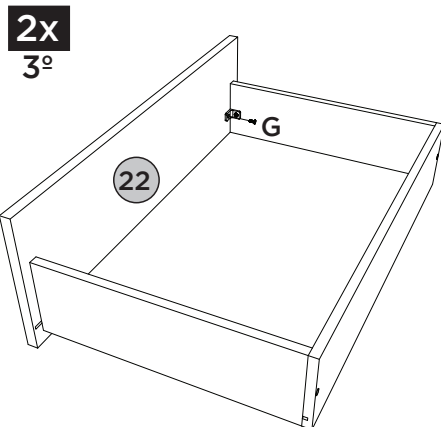
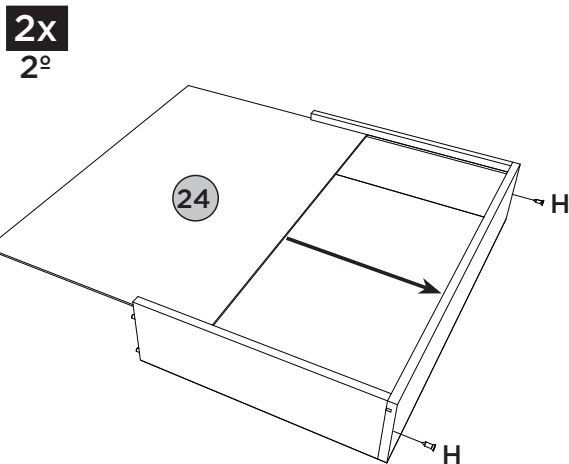
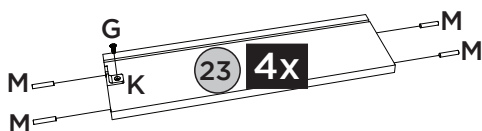
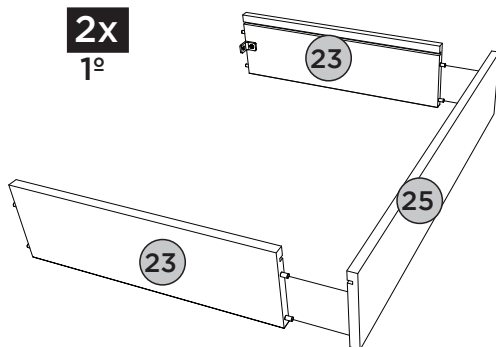
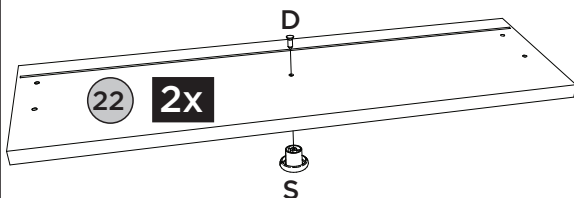
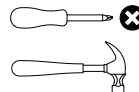

ACESSÓRIOS REQUERIDOS

E		04
G		12
N		04
X		04

FERRAMENTAS NECESSÁRIAS

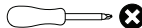

2x
4º

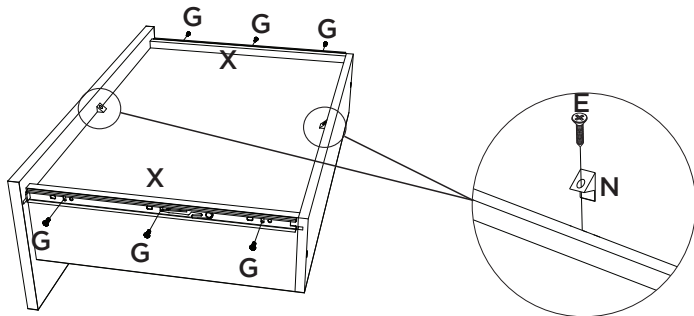

PASSO 15

ACESSÓRIOS REQUERIDOS

A		01
F		02
V		01
W		01

FERRAMENTAS NECESSÁRIAS

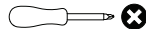

OU



Para parede: Ajustar no modo perfuração
Para peça (10): Usar torque 5



Imprescindível a fixação do produto na parede, a não colocação destas ferragens para fixação (A, F, V e W), poderá permitir que o produto vire, causando acidente.

Es imprescindible la fijación del producto en la pared, la no colocación de estos herrajes para fijación (A, F, V y W), podrá permitir que el producto se vuelva, causando accidente.

Indispensable to fix the product on the wall, not the placement of these attachment fittings (A, F, V and W) may allow the product to turn, causing an accident.

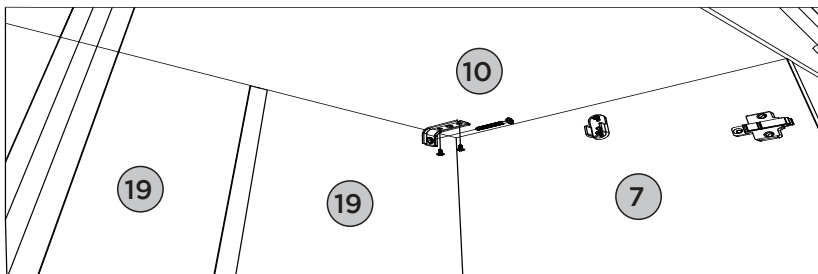
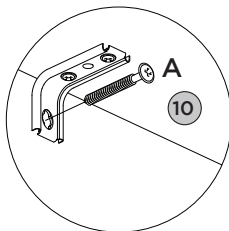
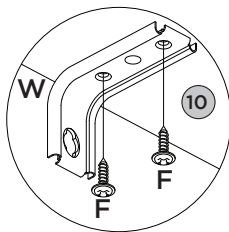

ACESSÓRIOS REQUERIDOS

AD	○	30
----	---	----

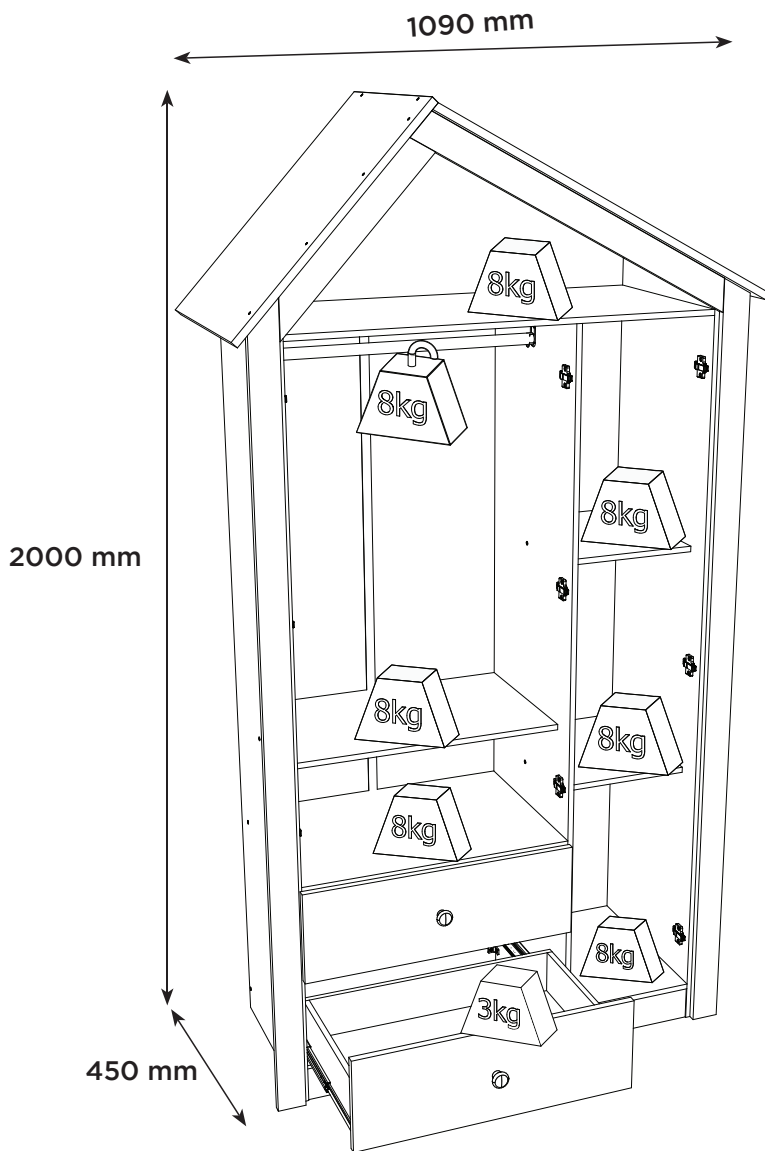

Pesos máximos recomendados com carga distribuída
 Peso máximo recomendado con la carga distribuida
 Recommended maximum weight with distributed load.

Produto Concluído
Producto terminado
Finished Product

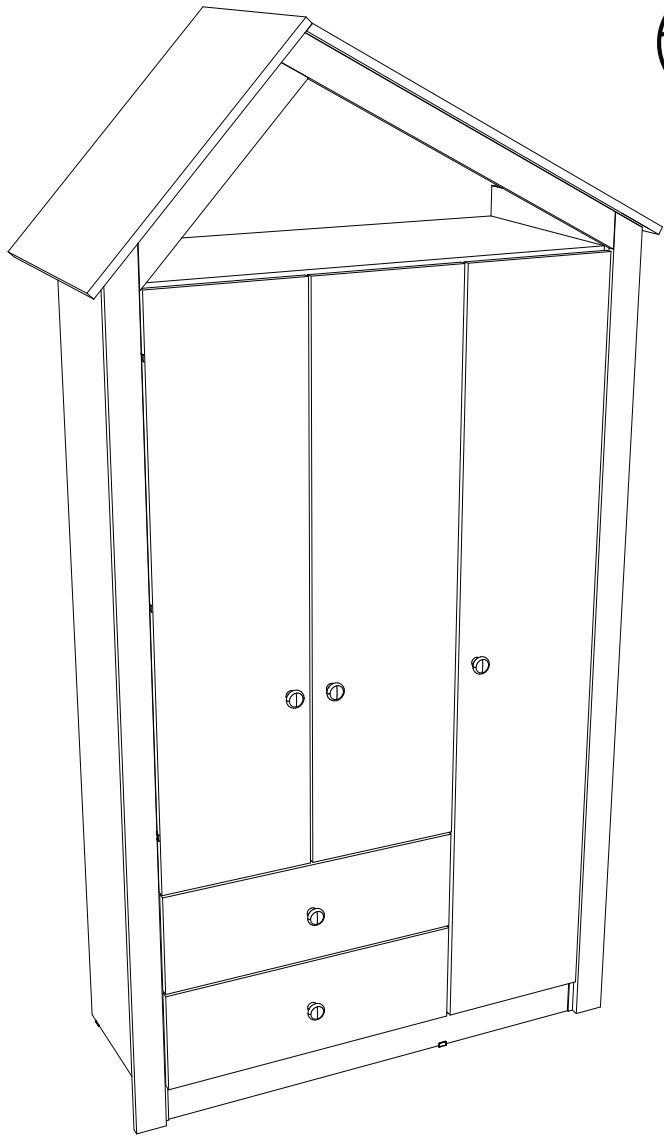

HENNInd. e Com. de Móveis Henn
Mondaí - SC - Brasil

☎ +55 49 3674.3500

📧 @moveishenn
www.henn.com.br**INSTRUÇÕES DE
MONTAGEM**INSTRUCCIONES DE MONTAJE
ASSEMBLY INSTRUCTIONS**Comoda Cafuné 1 Porta 3 Gavetas | Cómoda Cafuné 1 Puerta 3 Cajones |
Dresser Cafuné 1 Door 3 Drawers**

I718-18 Rústico/Branco

I718-165 Rústico/Rosa Chá

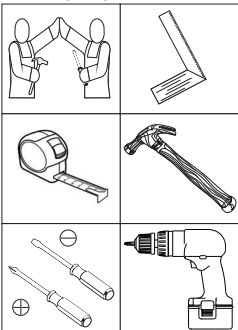
**Opção 1
Opción 1
Option 1****Opção 2
Opción 2
Option 2****Requisitos para montagem
Requisitos para la montaje
Assembly Requirements**

Imagens meramente ilustrativas,
não acompanha o produto.
Imágenes ilustrativas, no incluidas
con el producto.
Illustrative images, not included
with the product.

ASSISTÊNCIA TÉCNICA

Para solicitação de Assistência Técnica você consumidor deverá entrar em contato com o Lojista o qual você realizou a compra deste produto e solicitar a assistência técnica das peças avariadas. A garantia abrange todas as peças, partes e componentes que eventualmente venham apresentar defeito de fabricação no prazo de 03 (três) meses, contando a partir da entrega do produto ao consumidor, mediante nota fiscal de compra.

AVISO

Para limpeza de seu móvel, use uma flanela seca ou umedecida, e não utilize produtos químicos que possam danificar seu produto.

SISTEMA DE MONTAGEM

O sistema de montagem dos produtos funciona de acordo com a ordem crescente dos números indicados no desenho. Ex: 01, 02, 03, 04... até a conclusão da montagem.

ADVERTENCIA

Para limpieza de su móvil, use una franela seca o húmeda, y no utilice productos químicos que puedan dañar su producto.

SISTEMA DE MONTAJE

El sistema de montaje de los productos funciona de acuerdo con el orden creciente de los números indicados en el dibujo. Ej.: 01, 02, 03, 04... hasta la conclusión del montaje.

NOTICE

To clean your furniture, use a dry or wet cloth, and do not use chemicals that may damage your product.

ASSEMBLY SYSTEM

The products' assembly system works according to the increasing order of the indicated numbers. For example: 01, 02, 03, 04 ... to the end of the assembly.

ACESSÓRIOS | ACCESORIOS | ACCESSORIES

A

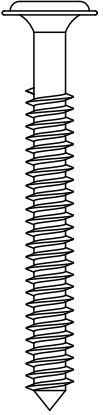

x1

B



x5

C

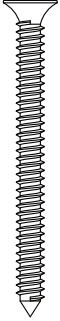

x19

D

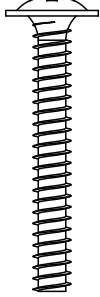

x4

E



x14

F



x48

G



x6

H

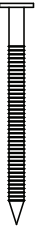

x6

I

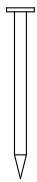

x39

J

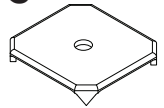

x10

K

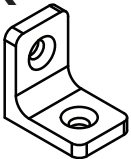

x8

L

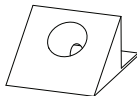

x6

M

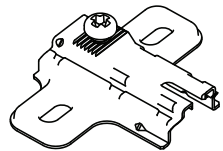

x2

Parafusos em escala
Tornillos escalados
Scaled screws

1:1

ACESSÓRIOS | ACCESORIOS | ACCESSORIES

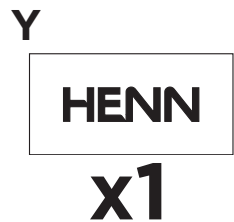
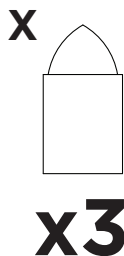
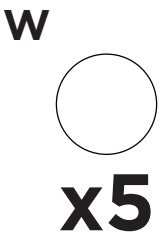
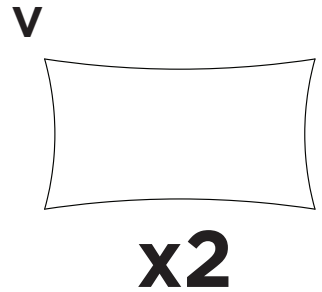
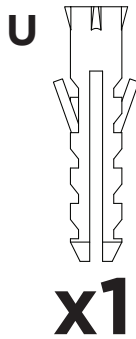
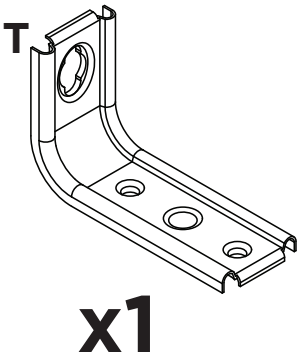
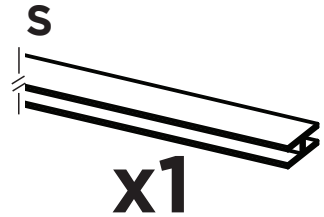
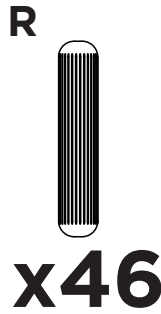
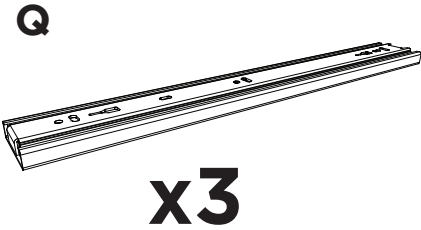
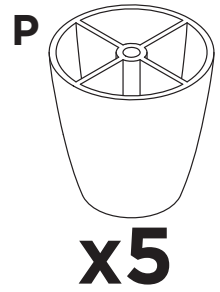
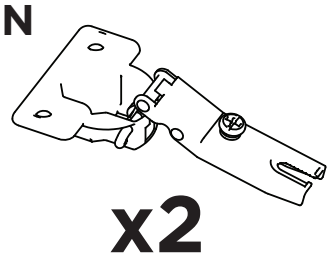

LISTA DE PEÇAS | LISTA DE PIEZAS | LIST OF PIECES

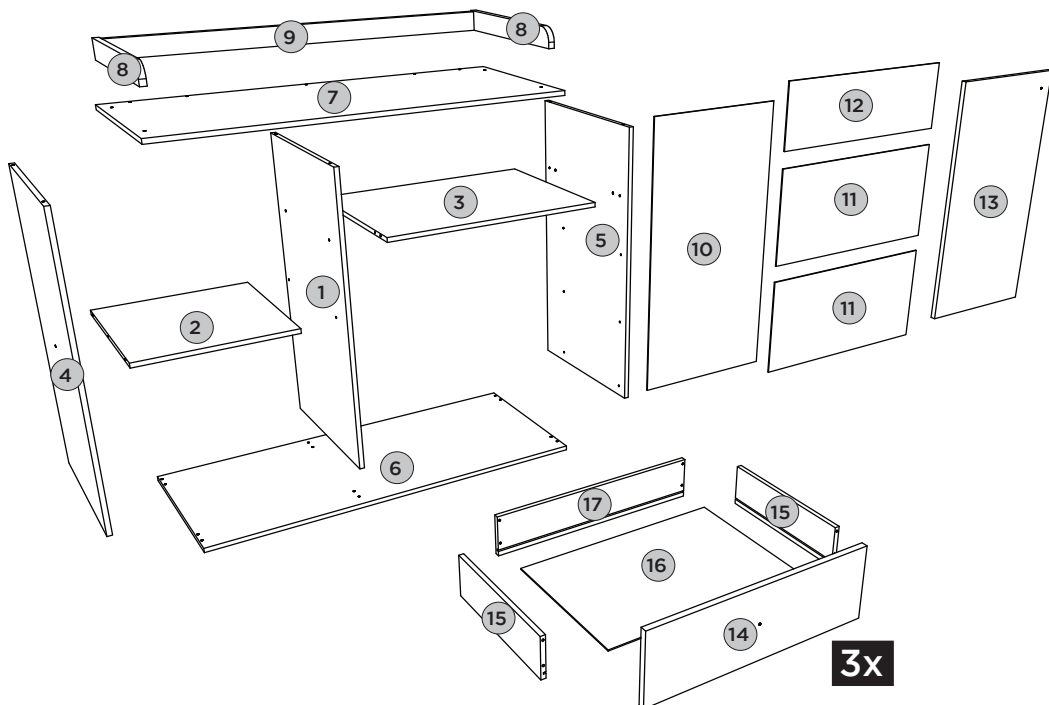



Item	Caja Caja Box	Qty Ctd Qty	Descrição Descripción Description	Dimensões (mm) Dimensiones (mm) Dimensions (mm)		
				Comprimento Largo Length	Largura Ancho Width	Espessura Grosor Thickness
1	1/1	01	DIVISÃO	772	410	12
2	1/1	01	PRATELEIRA FIXA	379	379	12
3	1/1	01	TAMPO DAS GAVETAS	563	410	12
4	1/1	01	LATERAL ESQUERDA	772	410	12
5	1/1	01	LATERAL DIREITA	772	410	12
6	1/1	01	BASE	980	410	12
7	1/1	01	TAMPO	980	410	12
8	1/1	02	MOLDURA LATERAL	390	50	15
9	1/1	01	MOLDURA SUPERIOR	917	48	15
10	1/1	01	FUNDO MAIOR	795	394	3
11	1/1	02	FUNDO CRU	296	577	3
12	1/1	01	FUNDO MENOR	577	200	3
13	1/1	01	PORTA	780	388	15
14	1/1	03	FRENTE DE GAVETA	571	192	15
15	1/1	06	LADO DE GAVETA	350	110	12
16	1/1	03	FUNDO DE GAVETA	530	361	3
17	1/1	03	RIPA DE TRÁS	543	110	12

PEÇAS REQUERIDAS

1	DIVISÃO	x1
2	PRATELEIRA FIXA	x1
3	TAMPO DAS GAVETAS	x1

ACESSÓRIOS REQUERIDOS

F		09
Q		03
R		12

FERRAMENTAS NECESSÁRIAS

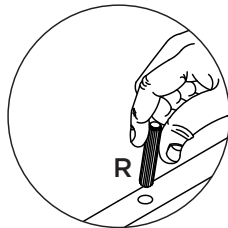
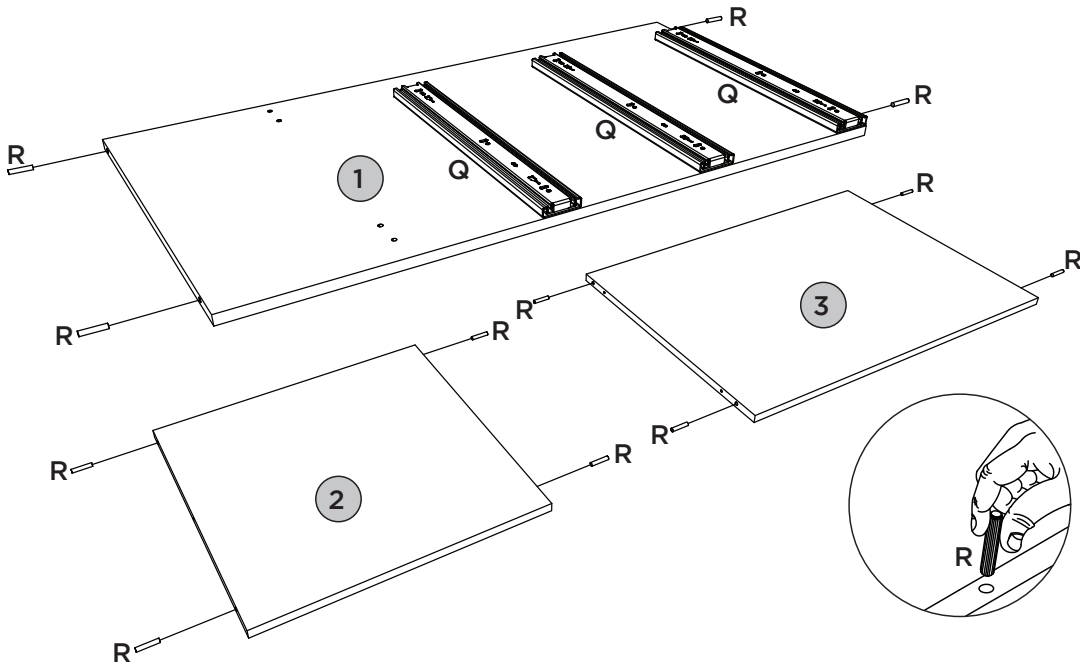
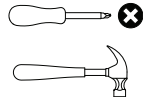

Fixar as correças nessas furações

Fijar las dapositivas de estos agujeros

Fix the slides in these holes

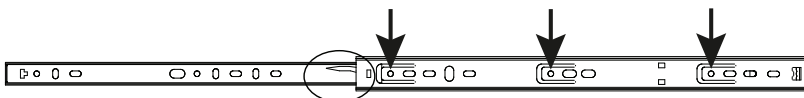
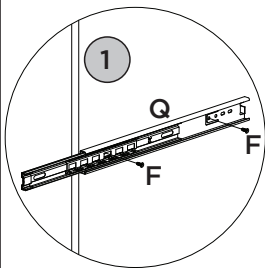

Para a desmontagem da correça, siga a instrução ao lado

Para el desmontaje de la diapositiva, siga las instrucciones en el lado

For disassembly of the slide, follow the instruction on the side

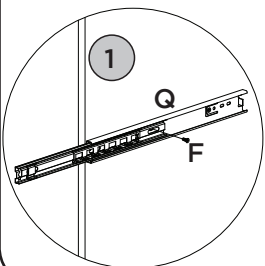
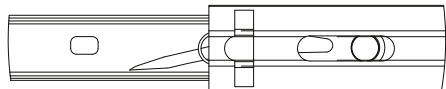
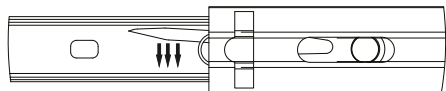

PEÇAS REQUERIDAS

4	LATERAL ESQUERDA	x1
5	LATERAL DIREITA	x1

ACESSÓRIOS REQUERIDOS

E		04
F		09
M		02
Q		03
R		08

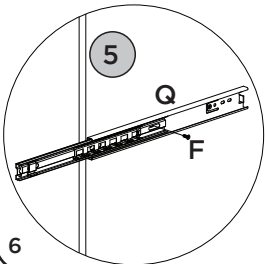
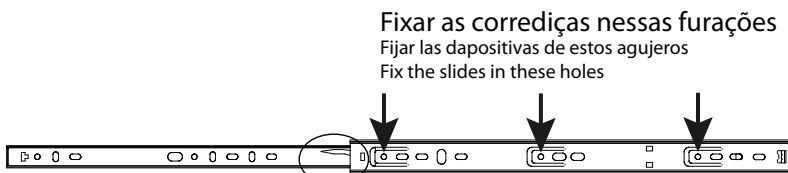
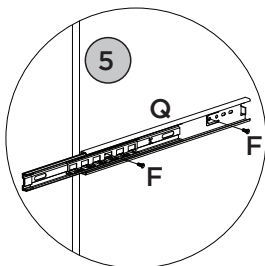
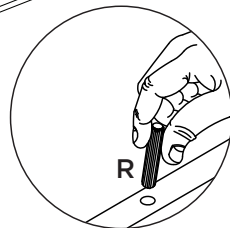
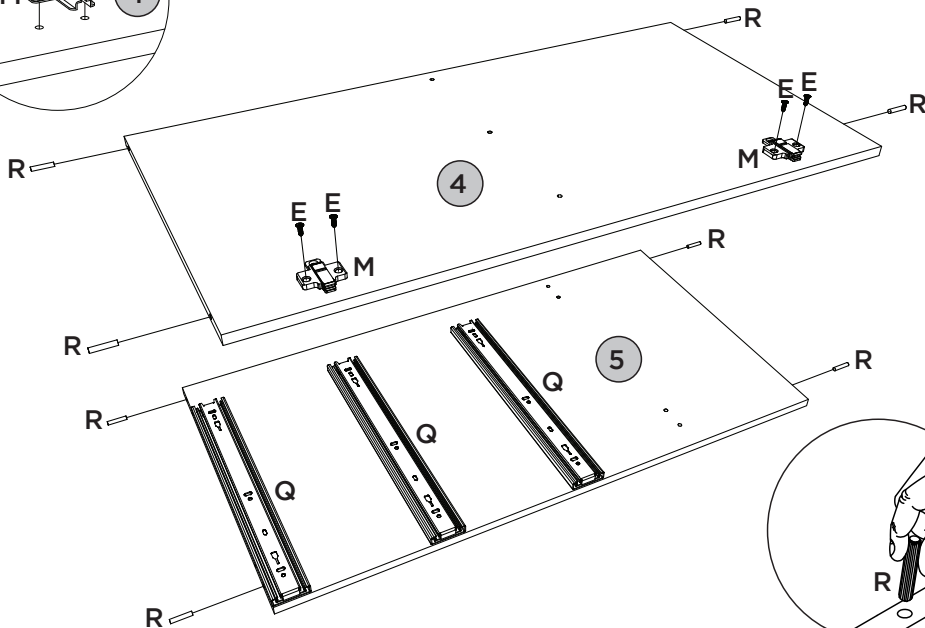
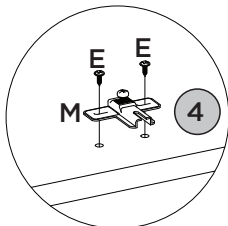
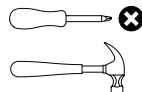
FERRAMENTAS NECESSÁRIAS

Para a desmontagem da correija, siga a instrução ao lado

Para el desmontaje de la diapositiva, siga las instrucciones en el lado

For disassembly of the slide, follow the instruction on the side

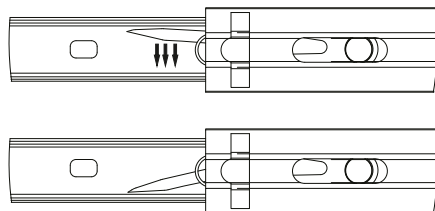

PASSO 3

ITM/1718-

PEÇAS REQUERIDAS

1	DIVISÃO	x1
2	PRATELEIRA FIXA	x1
3	TAMPO DAS GAVETAS	x1

ACESSÓRIOS REQUERIDOS

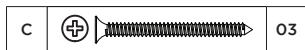

FERRAMENTAS NECESSÁRIAS

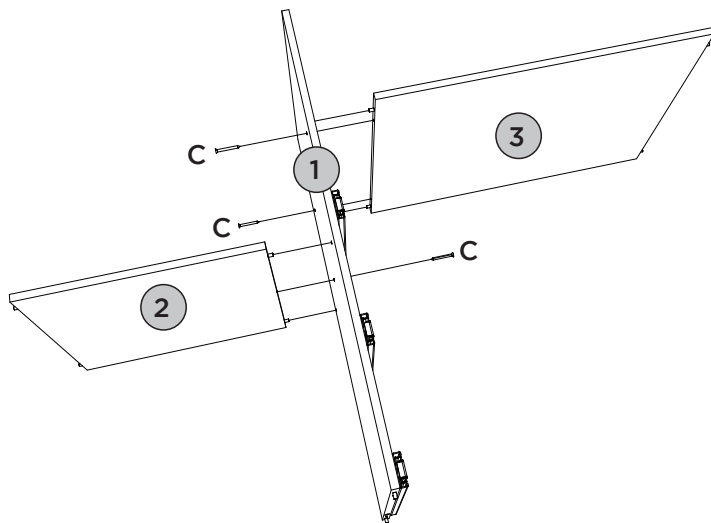
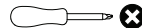

PASSO 4

PEÇAS REQUERIDAS

4	LATERAL ESQUERDA	x1
5	LATERAL DIREITA	x1

ACESSÓRIOS REQUERIDOS

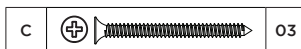



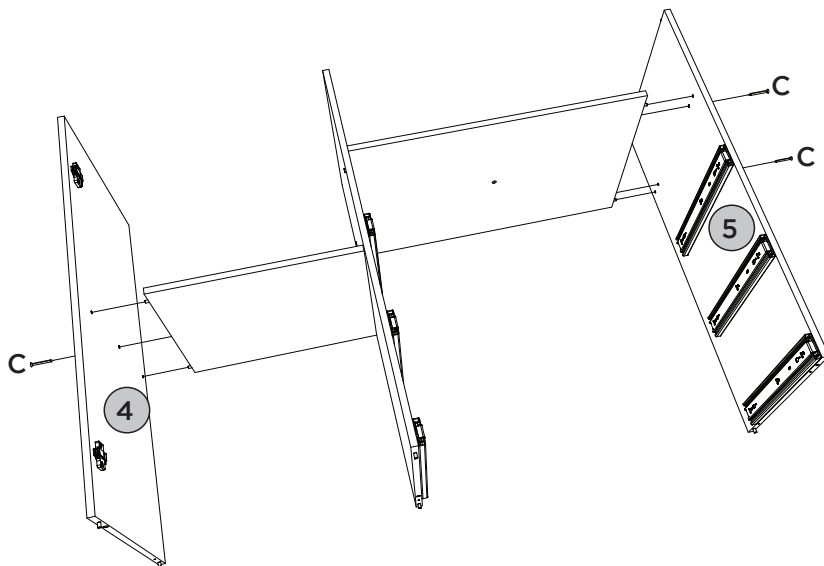
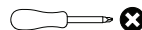

FERRAMENTAS NECESSÁRIAS

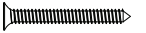

PEÇAS REQUERIDAS

6	BASE	x1
---	------	----

ACESSÓRIOS REQUERIDOS



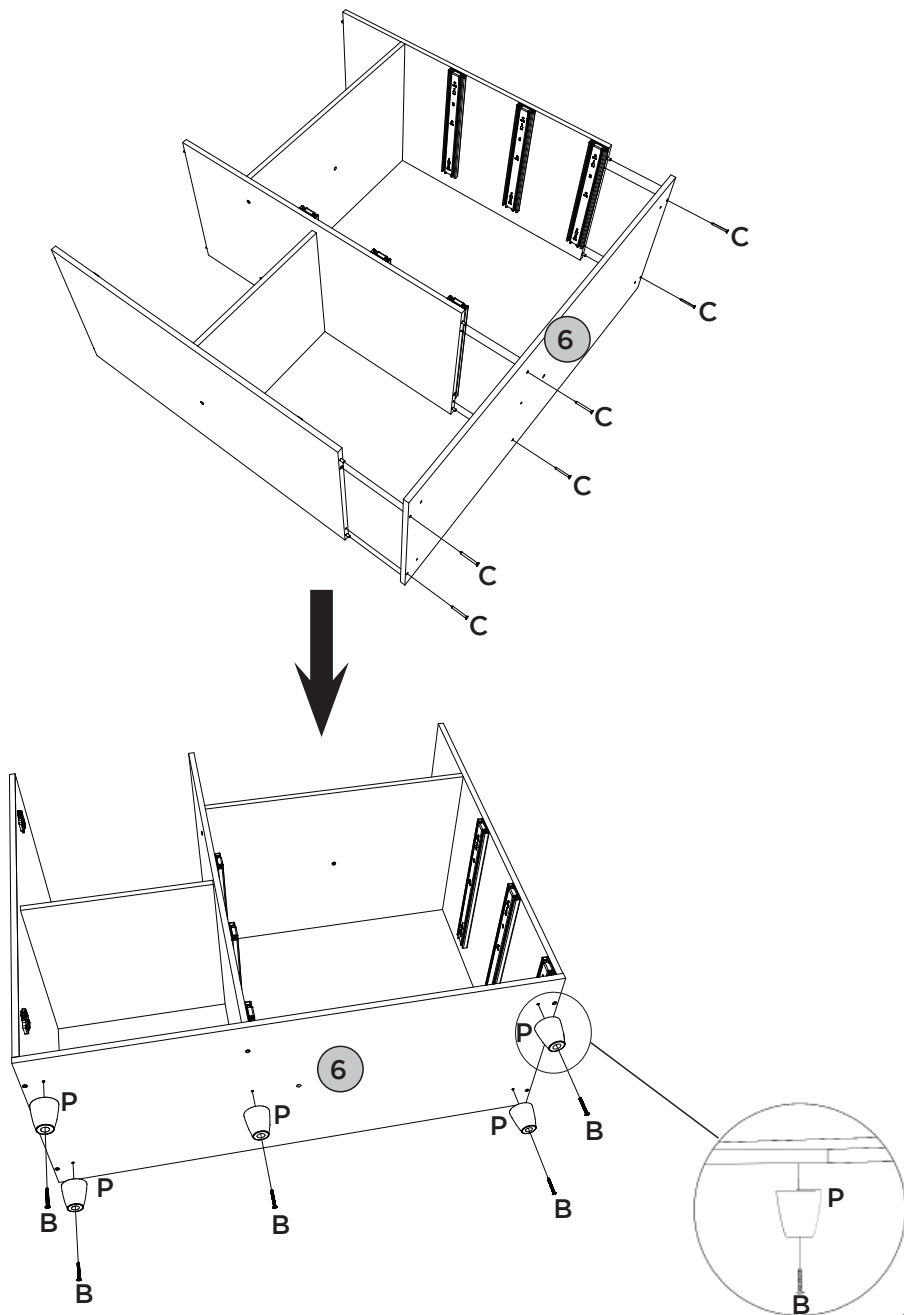
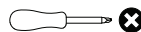

B			05
C			06
P			05

FERRAMENTAS NECESSÁRIAS

PEÇAS REQUERIDAS

7	TAMPO	x1
8	MOLDURA LATERAL	X2
9	MOLDURA SUPERIOR	x1

ACESSÓRIOS REQUERIDOS

B			07
R			02

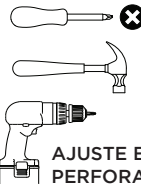
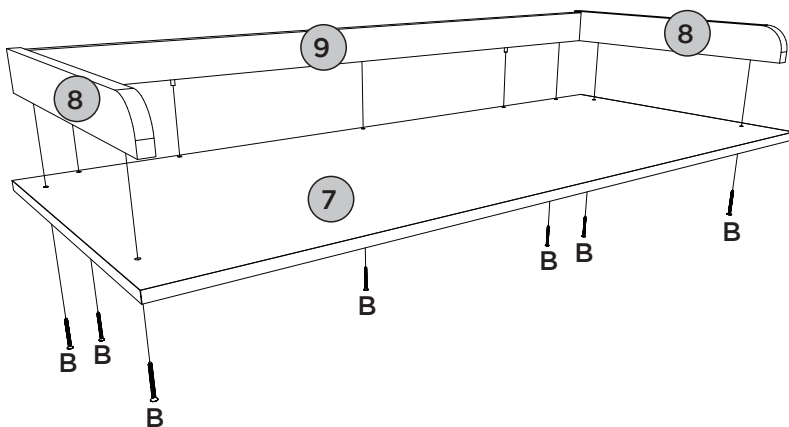
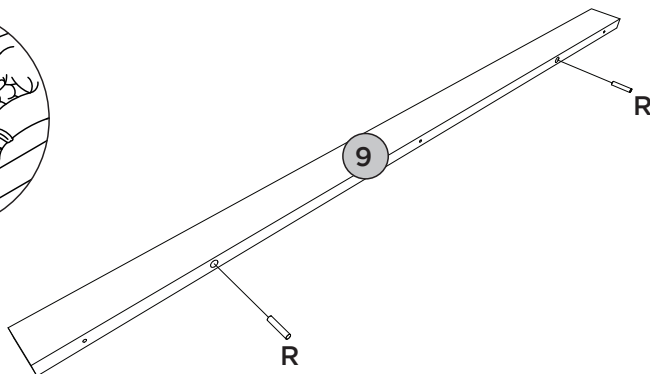
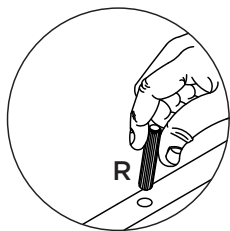
FERRAMENTAS NECESSÁRIAS

AJUSTE EN MODO PERFORACIÓN

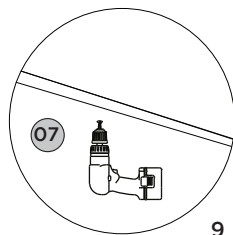

PARA COLOCAÇÃO DAS MOLDURAS NO TAMPO, É NECESSÁRIO FAZER A FURAÇÃO PASSANTE COM BROCA DE 5MM, UTILIZANDO COMO BASE AS PRÉ FURAÇÕES EXISTENTES NA PEÇA (7).

PARA COLOCAR LOS MARCOS EN LA PARTE SUPERIOR ES NECESARIO REALIZAR EL PERFORADO PASANTE CON TALADRO DE 5MM, UTILIZANDO COMO BASE LOS PRETALADRADOS EXISTENTES EN LA PIEZA (7).

TO PLACE THE FRAMES ON THE TOP, IT IS NECESSARY TO MAKE THE THROUGH DRILLING WITH A 5MM DRILL, USING AS A BASE THE EXISTING PRE DRILLINGS IN THE PART (7).

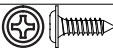

ACESSÓRIOS REQUERIDOS

E		04
K		02

FERRAMENTAS NECESSÁRIAS

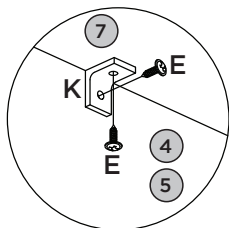
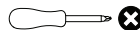

2 Cantoneiras próximo das bordas da frente das Laterais (04 e 05)

2 ángulos cerca de los bordes frontales de los lados (04 y 05)

2 Angles near the front edges of the Sides (04 and 05)

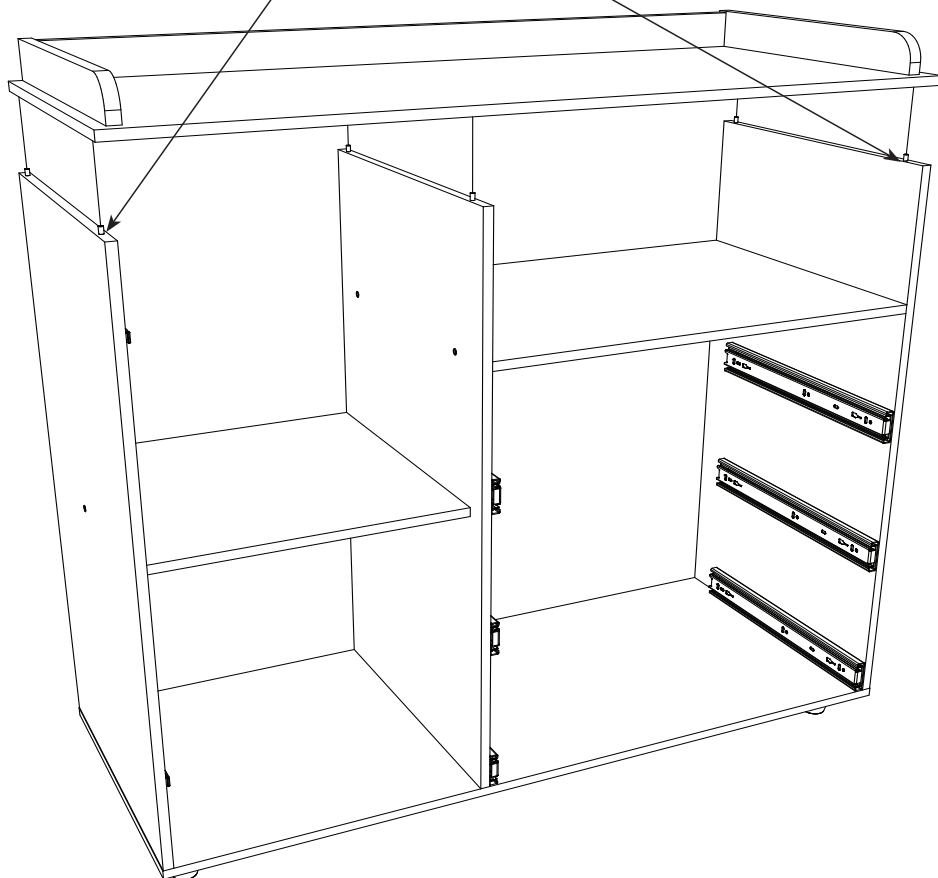



PASSO 8

ITM/1718-

PEÇAS REQUERIDAS

10	FUNDO MAIOR	x1
11	FUNDO CRU	x2
12	FUNDO MENOR	x1

ACESSÓRIOS REQUERIDOS

I		39
J		10
S		01



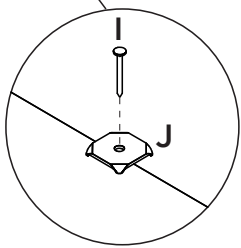
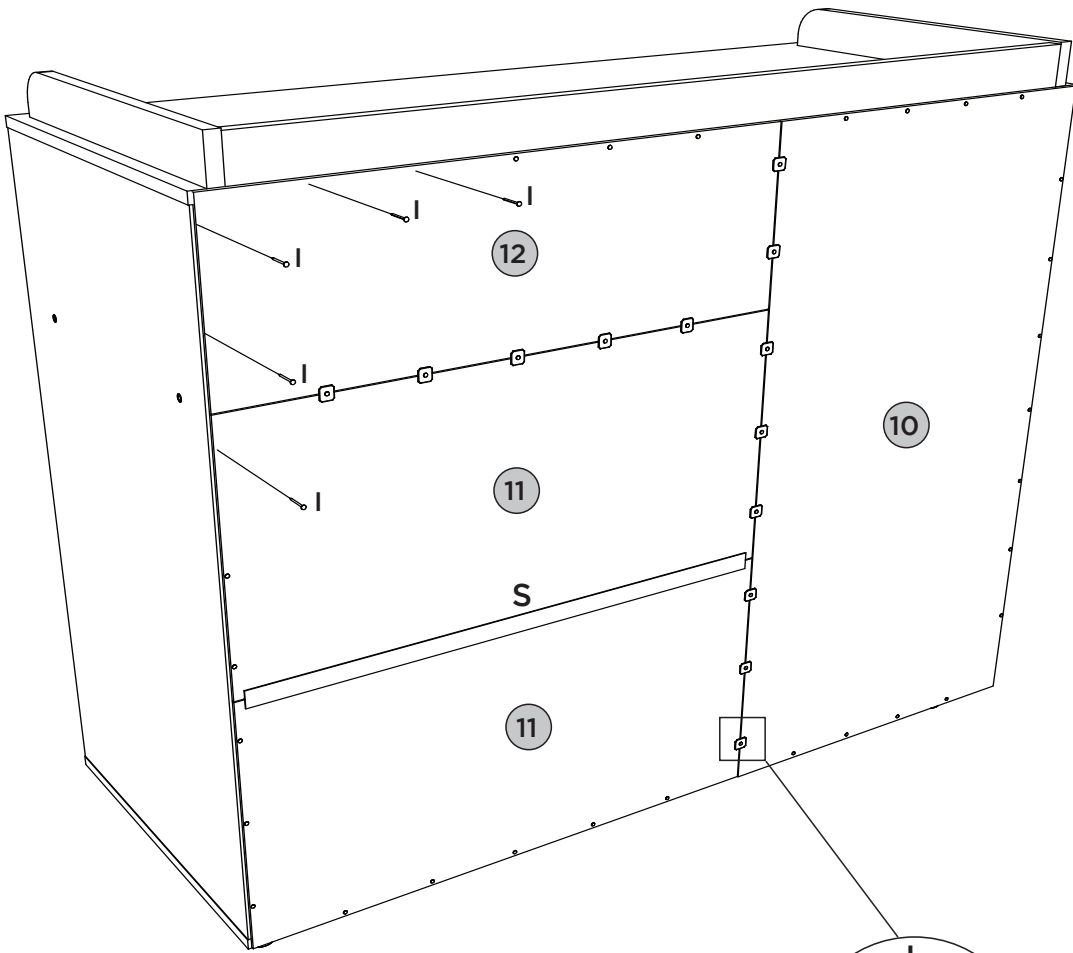

FERRAMENTAS NECESSÁRIAS



PEÇAS REQUERIDAS

13	PORTA	x1
----	-------	----

ACESSÓRIOS REQUERIDOS

D		01
E		04
N		02
O		01

FERRAMENTAS NECESSÁRIAS

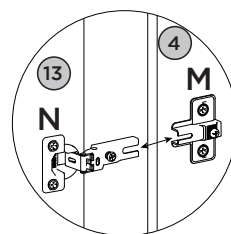
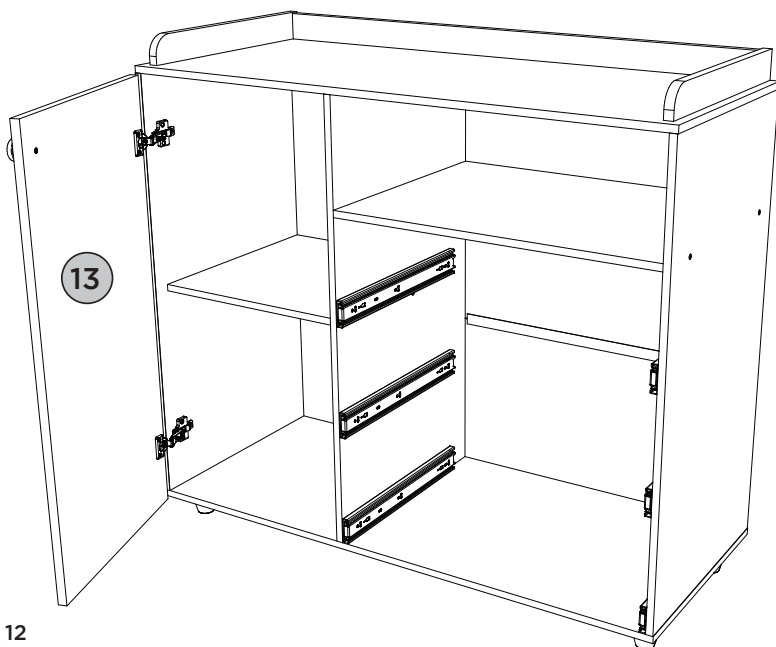
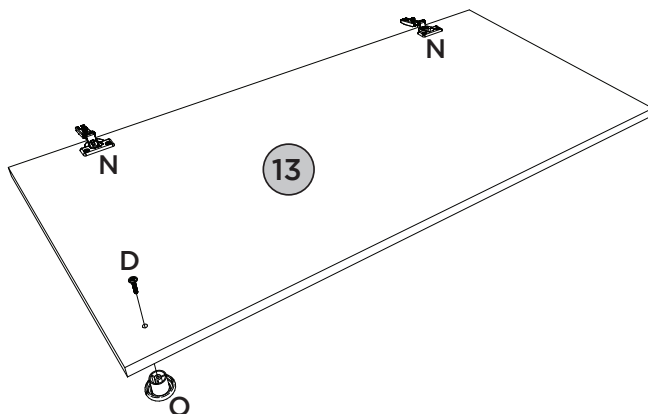
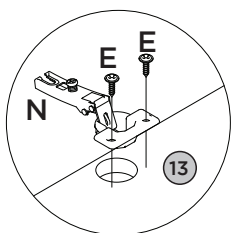
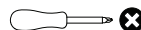

PASSO 10

ITM/1718-

PEÇAS REQUERIDAS

14	FRENTE DE GAVETA	x3
15	LADO DE GAVETA	x6

ACESSÓRIOS REQUERIDOS

D		03
F		06
K		06
O		03
R		24
V		

FERRAMENTAS NECESSÁRIAS

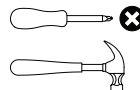

Cantoneira próximo da borda do lado de gaveta (15)

Soporte en ángulo cerca del borde del lado del cajón (15)

Angle bracket near edge of drawer side (15)

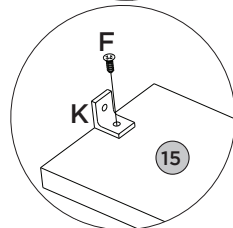
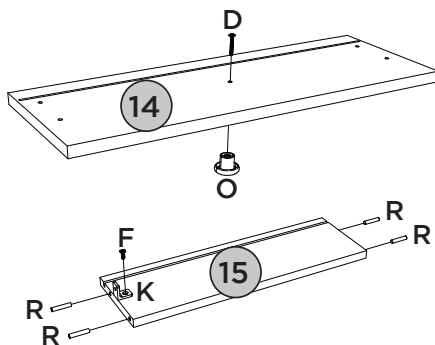

PASSO 11

PEÇAS REQUERIDAS

15	LADO DE GAVETA	x6
16	FUNDO DE GAVETA	x3
17	RIPA DE TRÁS	x3

ACESSÓRIOS REQUERIDOS

H		06
V		

FERRAMENTAS NECESSÁRIAS

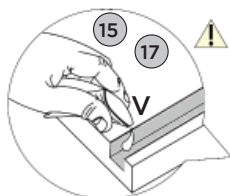
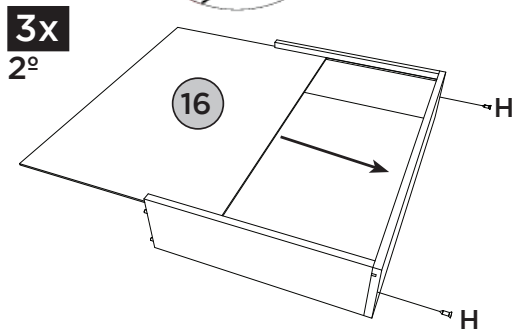
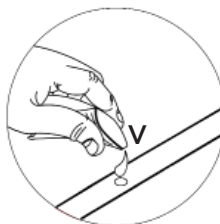
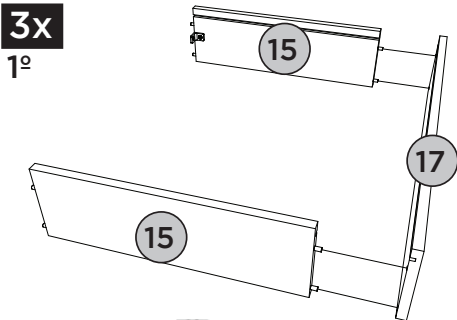

PEÇAS REQUERIDAS

14	FRENTE DE GAVETA	x3
----	------------------	----

ACESSÓRIOS REQUERIDOS

F		24
G		06
L		06
Q		03
V		

FERRAMENTAS NECESSÁRIAS

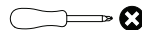
3x

3º

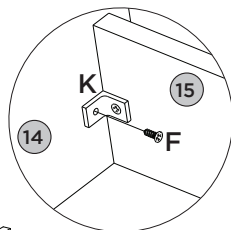
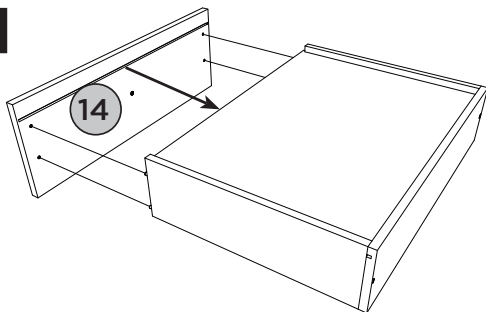



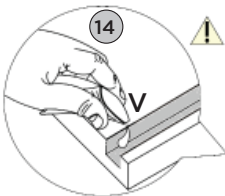
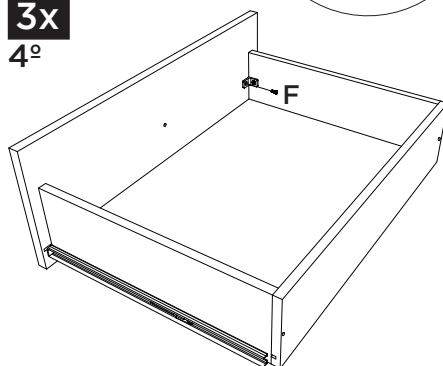

3x

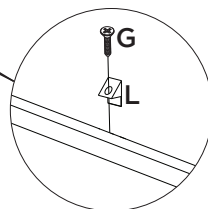
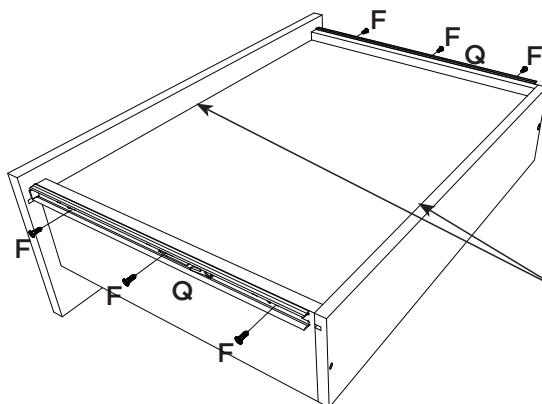
4º

3x

5º



ACESSÓRIOS REQUERIDOS		
A		01
E		02
T		01
U		01
W		05
X		03
Y	HENN	01

FERRAMENTAS NECESSÁRIAS



OU

Para parede: Ajustar no modo perfuração
Para peça (1): Usar torque 5

Pesos máximos recomendados com carga distribuída
Peso máximo recomendado con la carga distribuida
Recommended maximum weight with distributed load.

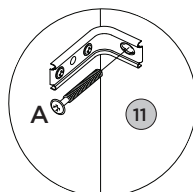
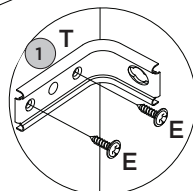
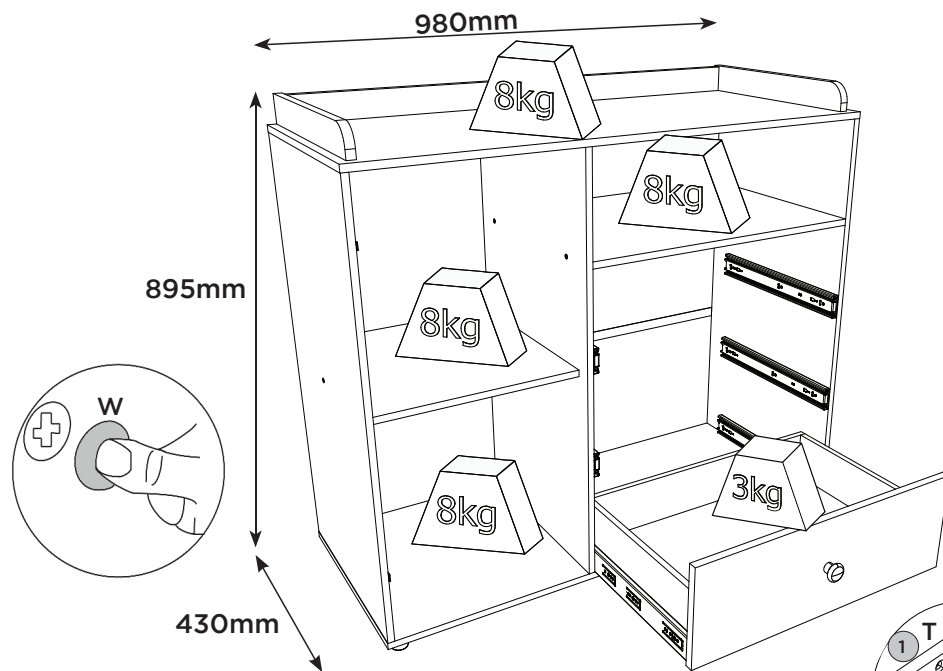

Imprescindível a fixação do produto na parede, a não colocação destas ferragens para fixação (A, E, T e U), poderá permitir que o produto vire, causando acidente.

Es imprescindible la fijación del producto en la pared, la no colocación de estos herrajes para fijación (A, E, T y U), podrá permitir que el producto se vuelva, causando accidente.

Indispensable to fix the product on the wall, not the placement of these attachment fittings (A, E, T and U) may allow the product to turn, causing an accident.

Produto Concluído
Producto terminado
Finished Product

ITM/1718-
REV- 001



HENN

Ind. e Com. de Móveis Henn
Mondai - SC - Brasil

+55 49 3674.3500

@moveishenn
www.henn.com.br

INSTRUÇÕES DE MONTAGEM



Vídeo de Montagem
Video de montaje
Assembly Video

INSTRUCCIONES DE MONTAJE
ASSEMBLY INSTRUCTIONS

Berço Mini Cama Bala de Menta Cuna Mini Cama Bala de Menta Crib Bala de Menta

- I02-10 Branco
- I02-18 Rústico/Branco

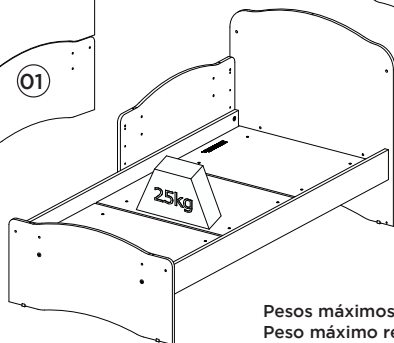
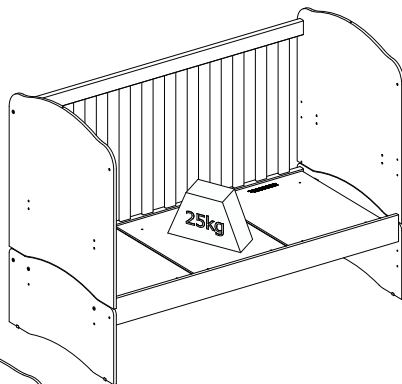
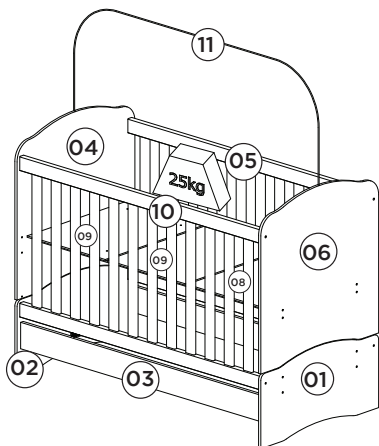

Pesos máximos recomendados com carga distribuída
Peso máximo recomendado con la carga distribuída
Recommended maximum weight with distributed load.

Requisitos para montagem Requisitos para la montaje Assembly Requirements

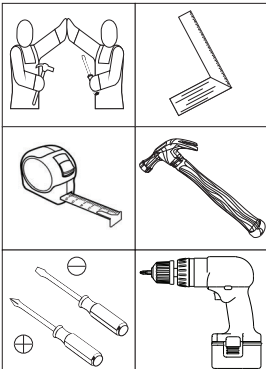

Imagens meramente ilustrativas
Imágenes meramente ilustrativas
Images for illustration only

AVISO

Para limpeza de seu móvel, use uma flanela seca ou umedecida, e não utilize produtos químicos que possam danificar seu produto.

SISTEMA DE MONTAGEM

O sistema de montagem dos produtos, funciona de acordo com a ordem crescente dos números indicados no desenho. Ex: 01, 02, 03, 04... até a conclusão da montagem.

ADVERTENCIA

Para limpieza de su móvil, use una flanela seca o húmeda, y no utilice productos químicos que puedan dañar su producto.

SISTEMA DE MONTAJE

El sistema de montaje de los productos funciona de acuerdo con el orden creciente de los números indicados en el dibujo. Ej.: 01, 02, 03, 04... hasta la conclusión del montaje.

NOTICE

To clean your furniture, use a dry or wet cloth, and do not use chemicals that may damage your product.

ASSEMBLY SYSTEM

The products' assembly system works according to the increasing order of the indicated numbers. For example: 01, 02, 03, 04 ... to the end of the assembly.

IMPORTANTE LER COM ATENÇÃO E GUARDAR PARA EVENTUAIS CONSULTAS

- I) **Advertências:** Não posicionar ou utilizar o produto perto de chama aberta e outras fontes de calor, tais como aquecedores elétricos, aquecedores a gás ou outras fontes, pois o material é inflamável.
- II) Não utilize o berço se alguma parte estiver quebrada, rasgada ou faltando. Utilizar somente peças de reposição recomendadas pelo fabricante.
- III) Não deixe nenhum objeto dentro ou próximo ao berço que possa servir de ponto de apoio ou ofereça risco de sufocação, engasgamento ou estrangulamento, como, por exemplo, cordas, cordões de persianas/cortina, protetores, almofadas, brinquedos, fios e cabos de aparelhos elétricos.
- IV) Nunca utilizar mais de um colchão no berço.
- V) Crianças pequenas não podem brincar, sem vigilância, nas proximidades de um berço.
- VI) Atenção: quando a criança for capaz de escalar o berço, ele não pode mais ser utilizado por essa criança, pois este berço foi construído para uso por crianças com capacidade motora para sentar-se, ajoelhar-se e/ou levantar-se sozinhas, porém que ainda não sejam capazes de escalar o berço.
- VII) Para berços com mais de uma função, não sujeita à regulamentação: Este produto atende à regulamentação para berços infantis, não sendo as suas demais funções sujeitas à regulamentação.
- VIII) Este berço não pode ser alterado, seja em sua estrutura ou em seus adornos, pois riscos à segurança da criança podem ser gerados.
- IX) O comprimento e a largura do colchão utilizado com o berço devem atender as especificações deste Manual.
- I) **Orientações:** A Sociedade Brasileira de Pediatria orienta colocar o bebê para dormir de barriga para cima, pois diminui em 70% o risco de morte súbita. Recomendamos conversar com o pediatra de seu filho para maiores informações.
- II) Só utilize o berço quando estiver totalmente montado conforme as orientações do Manual de Instruções e após certificar que seus sistemas de travamento estão devidamente acionados.
- III) O Berço deve ser colocado sobre um piso horizontal.
- IV) Para berços com altura da base ajustável: A posição mais baixa é a mais segura e a base deve ser sempre utilizada nessa posição tão logo o bebê tenha idade suficiente para sentar-se.
- V) Quando existirem dispositivos de apoio destacáveis para apoiar a base do berço acima da sua posição mais baixa: Antes que o berço seja utilizado na sua posição mais baixa, devem ser removidos os dispositivos usados para apoiar a base em posições mais altas.
- VI) As conexões de montagem devem ser sempre apertadas adequadamente e verificadas regularmente, ao longo do uso do berço, e reapertadas conforme necessário.
- VII) Caso alguma parte do berço quebre ou apresente defeito, deve-se procurar assistência técnica especializada e não serem realizados consertos caseiros.
- VIII) Orientações para a espessura do colchão, que podem ser dadas pelas seguintes formas:
- a) O comprimento e a largura do colchão utilizado com o berço devem ser tais que nunca seja possível a formação de espaço maior que 30mm entre as laterais ou extremidades e o colchão.
- b) A espessura do colchão deve ser tal que a altura interna (da superfície do colchão até a borda superior da armação do berço) seja de pelo menos 480mm na posição mais baixa da base do berço e pelo menos 180mm na posição mais elevada da base do berço.
- c) Quando for utilizada uma marcação no berço para indicar a espessura máxima do colchão: A marcação no berço indica a espessura máxima do colchão a ser utilizado com o berço.
- IX) Recomendação sobre o tamanho do colchão a ser utilizado com o berço.
- Para o Berço Mini Cama Bala de Menta, recomenda-se o uso de colchão de 1,30 m \pm 0,5 cm de comprimento, 60 cm \pm 0,5 cm de largura e 12 cm \pm 0,5 cm de altura, com densidade mínima de 18 kg/m³ \pm 2,0 kg/m³ (D18).

IMPORTANTE LEER CON ATENCIÓN Y GUARDAR PARA EVENTUALES CONSULTAS

I) **Advertencias:** No colocar o utilizar el producto cerca de llama abierta y otras fuentes de calor, tales como calentadores eléctricos, calentadores de gas u otras fuentes, ya que el material es inflamable.

II) No utilice la cuna si alguna parte está rota, rasgada o faltada. Utilice sólo piezas de repuesto recomendadas por el fabricante.

III) No deje ningún objeto dentro o cerca de la cuna que pueda servir de punto de apoyo o ofrezca riesgo de sofocación, engaño o estrangulamiento, como por ejemplo cuerdas, cordones de persianas / cortinas, protectores, cojines, juguetes, hilos y cables de aparatos eléctricos.

IV) Nunca utilizar más de un colchón en la cuna.

V) Los niños pequeños no pueden jugar, sin vigilancia, en las proximidades de una cuna.

VI) Atención: cuando el niño es capaz de escalar la cuna, ya no puede ser utilizado por ese niño, pues esta cuna fue construida para uso por niños con capacidad motora para sentarse, arrodillarse y / o levantarse pero que todavía no son capaces de escalar la cuna.

VII) Para cunas con más de una función, no sujeta a la reglamentación: Este producto atiende a la reglamentación para cunas infantiles, no siendo sus demás funciones sujetas a la reglamentación.

VIII) Esta cuna no puede ser alterada, sea en su estructura o en sus adornos, pues riesgos a la seguridad del niño pueden ser generados.

IX) La longitud y la anchura del colchón utilizado con la cuna deben cumplir las especificaciones de este manual.

I) **Orientaciones:** La Sociedad Brasileña de Pediatría orienta a colocar al bebé para dormir de barriga hacia arriba, pues disminuye en un 70% el riesgo de muerte súbita. Recomendamos consultar con el pediatra de su hijo para mayor información.

II) Sólo utilice la cuna cuando esté totalmente montado de acuerdo con las instrucciones del Manual de instrucciones y después de asegurarse de que sus sistemas de bloqueo están debidamente accionados.

III) La cuna debe colocarse sobre un piso horizontal.

IV) Para cunas con altura de base ajustable: La posición más baja es la más segura y la base debe ser siempre utilizada en esa posición tan pronto como el bebé tenga la edad suficiente para sentarse.

V) Cuando existan dispositivos de apoyo desmontables para apoyar la base de la cuna por encima de su posición más baja: Antes de que la cuna se utilice en su posición más baja, se deben quitar los dispositivos utilizados para apoyar la base en posiciones más altas.

VI) Las conexiones de montaje siempre deben ajustarse adecuadamente y verificadas regularmente, a lo largo del uso de la cuna, y reapertadas según sea necesario. VII) Si alguna parte de la cuna se rompe o presenta defecto, se debe buscar asistencia técnica especializada y no realizar reparaciones caseras.

VIII) Orientaciones para el espesor del colchón, que pueden darse de las siguientes formas:

a) La longitud y la anchura del colchón utilizado con la cuna deben ser tales que nunca sea posible la formación de espacio mayor a 30 mm entre los laterales o los extremos y el colchón.

b) El espesor del colchón debe ser tal que la altura interna (de la superficie del colchón hasta el borde superior del armazón de la cuna) sea de al menos 480 mm en la posición más baja de la base de la cuna y al menos 180 mm en la posición más elevada de la base de la cuna.

c) cuando se utilice un marcado en la cuna para indicar el espesor máximo del colchón: El marcado en la cuna indica el grosor máximo del colchón que se utilizará con la cuna.

IX) Recomendación sobre el tamaño del colchón que se utilizará con la cuna. Para la Cuna Mini Cama Bala de Menta, se recomienda el uso de un colchón de $1,30 \text{ m} \pm 0,5 \text{ cm}$ longitud, $60 \text{ cm} \pm 0,5 \text{ cm}$ de ancho y $12 \text{ cm} \pm 0,5 \text{ cm}$ de alto, con una densidad mínima de $18 \text{ kg} / \text{m}^3 \pm 2,0 \text{ kg} / \text{m}^3$ (D18).

WARNING READ WITH ATTENTION AND SAVE FOR EVENTUAL CONSULTATIONS

- I) **Warnings:** Do not position or use the product near open flame and other sources of heat such as electric heaters, gas heaters or other sources as the material is flammable.
- II) Do not use the crib if any part is broken, torn or missing. Use only replacement parts recommended by the manufacturer.
- III) Do not leave any object in or near the crib that may serve as a foothold or risk of suffocation, choking or strangulation, such as ropes, blinds / curtain cords, protectors, cushions, toys, wires and cables of electrical appliances.
- IV) Never use more than one mattress in the crib.
- V) Small children may not play, unattended, in the vicinity of a crib.
- VI) Caution: when the child is able to climb the crib, it can no longer be used by this child, as this crib was built for use by children with motor ability to sit, kneel and / or get up alone but not yet able to climb the crib.
- VII) For cribs with more than one function, not subject to regulation: This product complies with regulations for baby cribs, and its other functions are not subject to regulation.
- VIII) This crib can not be altered, either in its structure or in its adornments, because risks to the child's safety can be generated.
- IX) The length and width of the mattress used with the crib must comply with the specifications of this Manual.
- I) **Guidelines:** The Brazilian Society of Pediatrics advises to place the baby to sleep on his belly up, as it reduces the risk of sudden death by 70%. We recommend talking to your child's pediatrician for more information.
- II) Only use the crib when fully assembled in accordance with the instructions in the Instruction Manual and after making sure that your locking systems are properly engaged.
- III) The crib must be placed on a horizontal floor.
- IV) For cribs with adjustable base height: The lowest position is the safest and the base should always be used in this position as soon as the baby is old enough to sit.
- V) When there are detachable supporting devices to support the crib base above its lowest position: Before the crib is used in its lowest position, the devices used to support the crib in the highest positions should be removed.
- VI) The mounting connections must always be tightened properly and checked regularly, throughout the use of the crib, and retightened as necessary.
- VII) If any part of the crib breaks or is defective, you should look for expert technical assistance and no home repairs.
- VIII) Guidelines for the thickness of the mattress, which may be given in the following ways:
- a) The length and width of the mattress used with the crib shall be such that it is never possible to form a space greater than 30 mm between the sides or ends and the mattress.
- b) The thickness of the mattress shall be such that the inner height (from the mattress surface to the upper edge of the cradle frame) is at least 480 mm in the lowest position of the cradle base and at least 180 mm in the highest position of the cradle of the crib.
- c) When a marking is used on the crib to indicate the maximum thickness of the mattress: The marking on the crib indicates the maximum thickness of the mattress to be used with the crib.
- IX) Recommendation on the minimum size of mattress to be used with the crib. For the Mint Bullet Mini Bed Crib, the use of a 1,30 m \pm 0,5 cm mattress is recommended length, 60 cm \pm 0,5 cm wide and 12 cm \pm 0,5 cm high, with a minimum density of 18 kg / m³ \pm 2,0 kg / m³ (D18).

**O REGISTRO NO INMETRO E O
SELO DE IDENTIFICAÇÃO DA
CONFORMIDADE REFEREM-SE
SOMENTE AO BERÇO**

**EL REGISTRO EN EL INMETRO Y
EL SELLO DE IDENTIFICACIÓN
DE LA CONFORMIDAD SE
REFERE SOLAMENTE AL BERZO**

**THE INMETRO REGISTRATION
AND THE CONFORMITY IDEN-
TIFICATION SEAL REFER ONLY
TO THE CRIB**

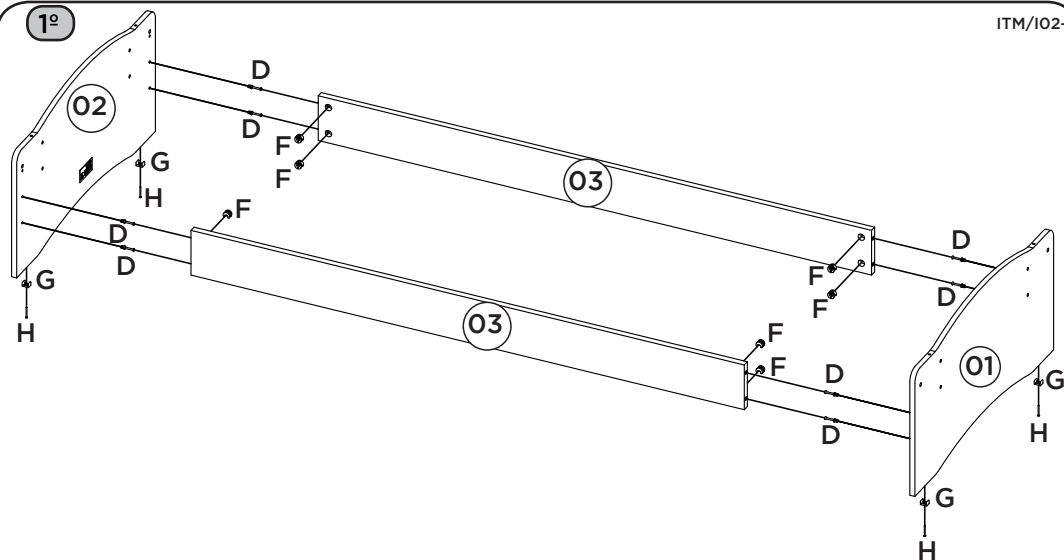

2º



Para não comprometer a estrutura do berço, o espaço entre as peças (03) e (05), não pode ser menor que 20mm e maior que 23mm.

Para no comprometer la estructura de la cuna, el espacio entre las piezas (03) y (05), no puede ser menor que 20mm y mayor que 23mm.

In order not to compromise the structure of the cradle, the space between parts (03) and (05) can not be less than 20mm and greater than 23mm.

Utilizar a parafusadeira com o torque em 15 para fixar a grade e para fixar o lastro.

Utilizar la atornilladora con el torque en 15 para fijar la rejilla y para fijar el lastre.

Use the screwdriver with the torque at 15 to attach the rail and base frame.

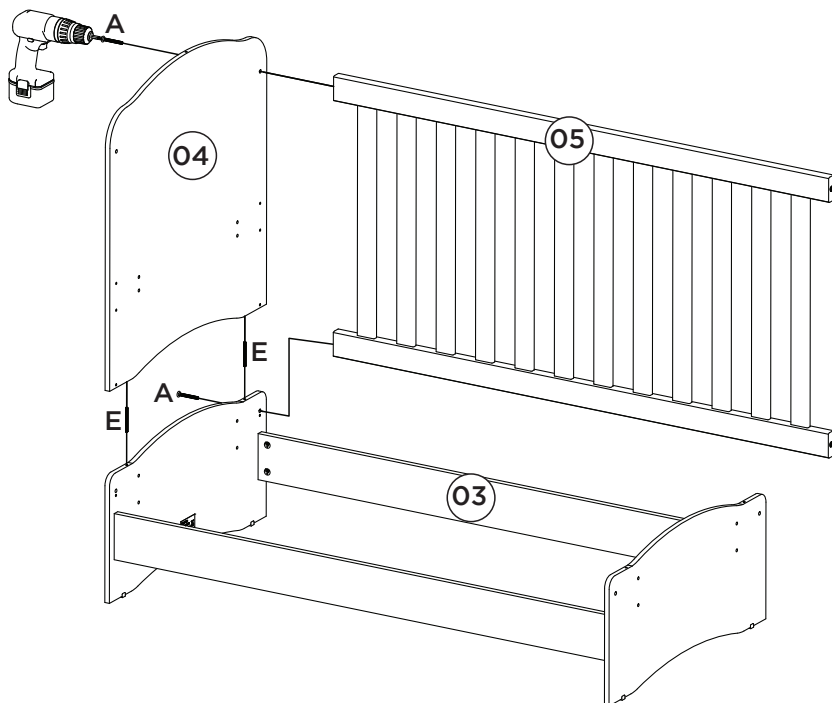

3º

ITM/102-

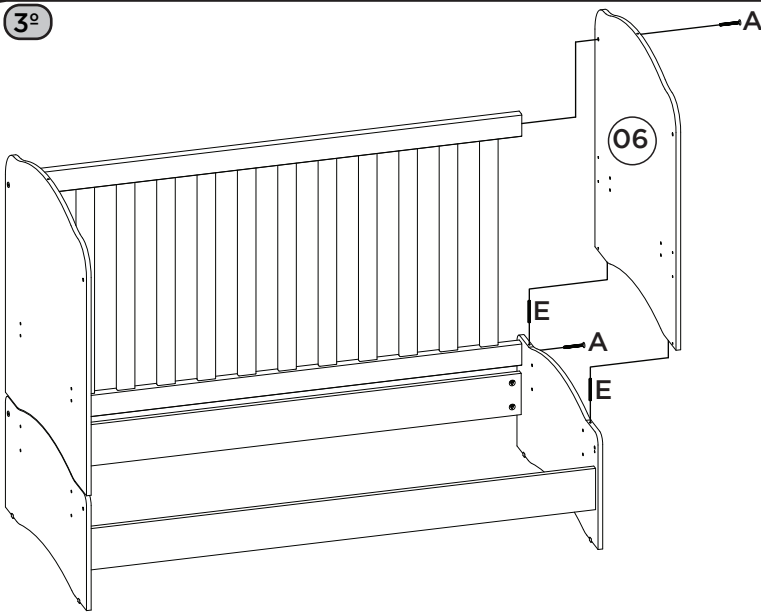

Fixar parafuso (A) antes de fixar a peça nº 06

Fijar tornillo (A) antes de fijar la pieza nº 06

Secure bolt (A) before securing part 06

4º



Opções para montar o Lastro

Opções para montar o Lastro

Opções para montar o Lastro

Furação para Berço - Opção mais alta do lastro

Perforación de cuna - Opción de lastre superior

Cradle Drilling - Higher Ballast Option

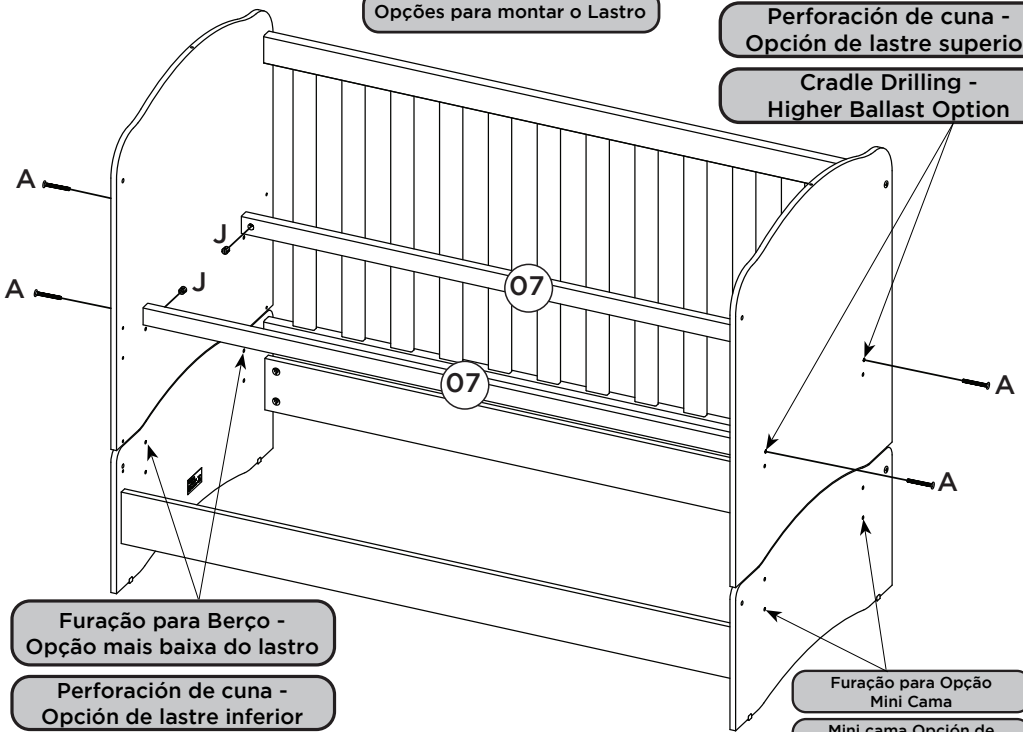

Furação para Berço - Opção mais baixa do lastro

Perforación de cuna - Opción de lastre inferior

Cradle Drilling - Lower Ballast Option

Furação para Opção Mini Cama

Mini cama Opción de perforación

Mini Bed Option Drilling

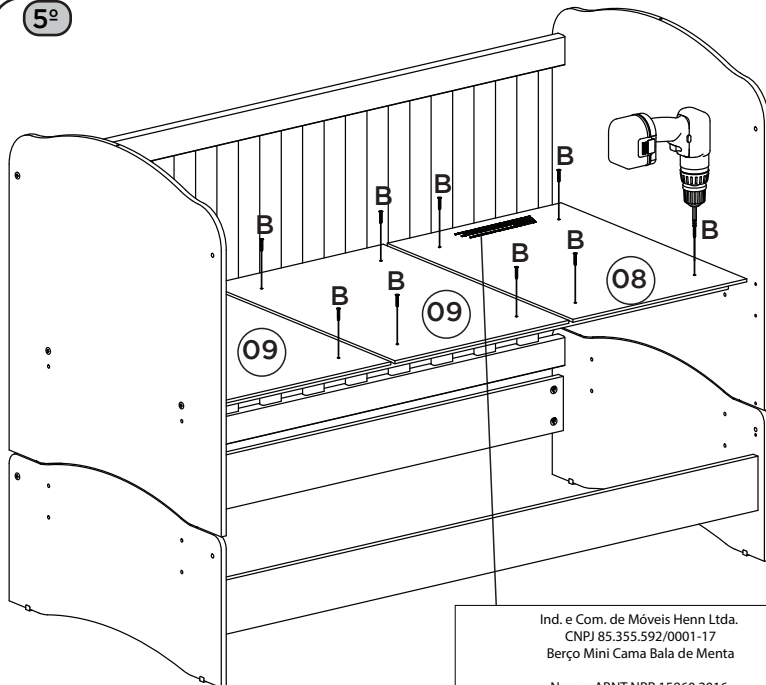

Utilizar a parafusadeira com o torque em 15 para fixar a grade e para fixar o lastro.

Utilizar la atornilladora con el torque en 15 para fijar la rejilla y para fijar el lastre.

Use the screwdriver with the torque at 15 to attach the rail and base frame.

Ind. e Com. de Móveis Henn Ltda.
CNPJ 85.355.592/0001-17
Berço Mini Cama Bala de Menta

Norma ABNT NBR 15860:2016;
Recomenda-se o uso de colchões com espessura máxima permitida de 120mm conforme ABNT NBR 13579-1.

PEDIDO: (numero) LOTE: (numero) DATA: (dia/mês/ano)

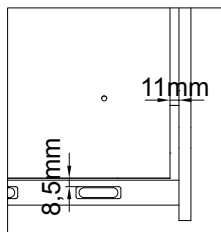

Para a opção mais alta a distância entre os lastros da extremidade com as laterais deverá ser de 11mm.

Para la opción más alta la distancia entre los lastres extremos con los laterales deberá ser de 11mm.

For the higher option the distance between the end base frame to the sides should be 11mm.

As extremidades dos lastros (08) e (09) devem ficar 8,5mm da grade fixa (05).

Lastres extremos (08) y (09) deben quedar 8,5mm de la rejilla fija (05).

The end base frames (08) and (09) must be 8,5mm from the fixed rail (05).

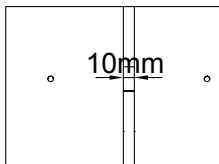

A distância entre os lastros deve ser 10mm.

La distancia entre los lastres debe ser 10mm.

The distance between ballast should be 10mm.

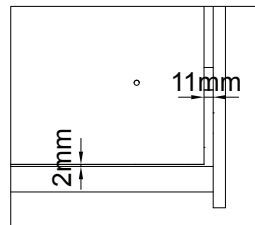

Para a opção mais baixa a distância entre os lastros da extremidade com as laterais deverá ser de 11mm.

Para la opción más baja la distancia entre los lastres extremos con los laterales deberá ser de 11mm.

For the lower option the distance between the end base frame to the sides should be 11mm.

As extremidades dos lastros (08) e (09) devem ficar 2mm da grade fixa (05).

Lastres extremos (08) y (09) deben quedar 2mm de la rejilla fija (05).

The end base frames (08) and (09) must be 2mm from the fixed rail (05).

Utilizar a parafusadeira com o torque em 15 para fixar a grade e para fixar o lastro.

Utilizar la atornilladora con el torque en 15 para fijar la rejilla y para fijar el lastre.

Use the screwdriver with the torque at 15 to attach the rail and base frame.

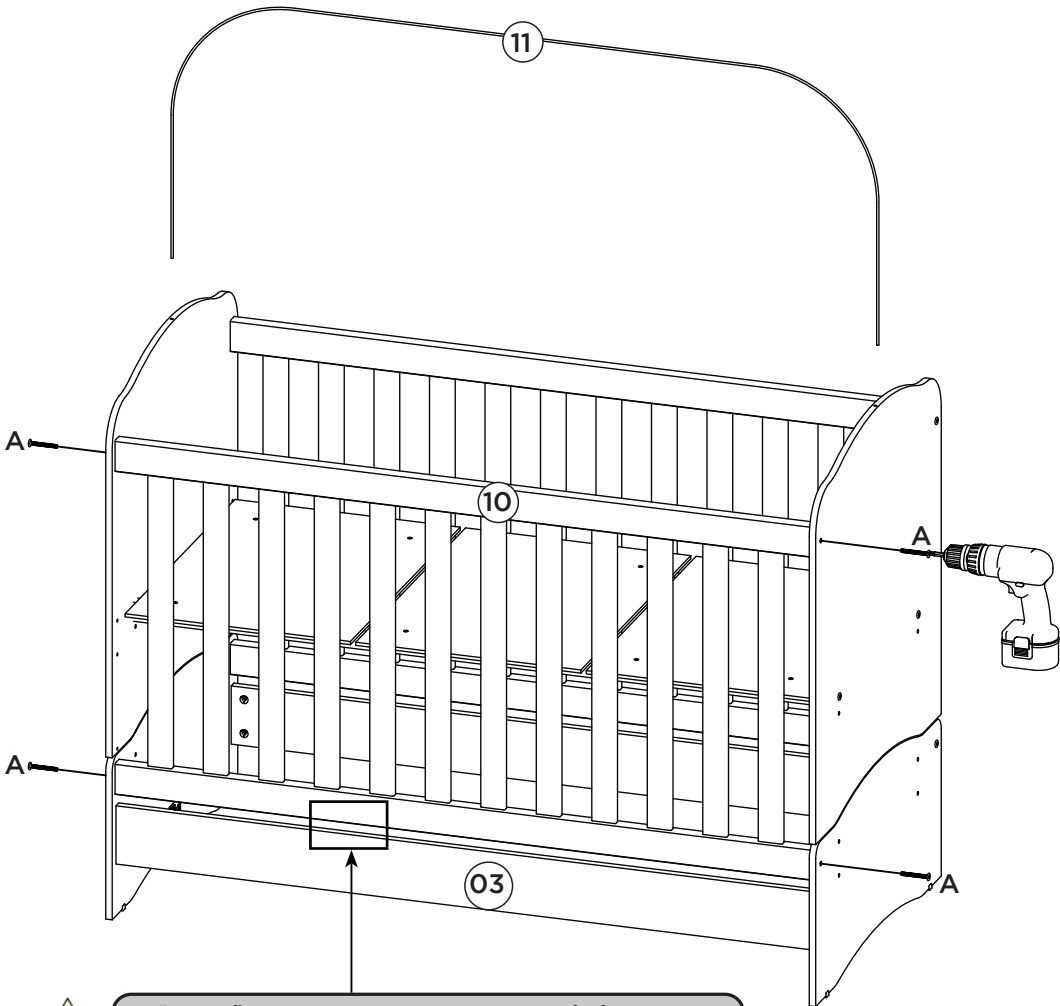

Para não comprometer a estrutura do berço, o espaço entre as peças (03) e (10), não pode ser menor que 20mm e maior que 23mm.

Para no comprometer la estructura de la cuna, el espacio entre las piezas (03) y (10), no puede ser menor que 20mm y mayor que 23mm.

In order not to compromise the structure of the cradle, the space between parts (03) and (10) can not be less than 20mm and greater than 23mm.

Montagem berço concluída

Montaje cuna completa

Completed crib assembling

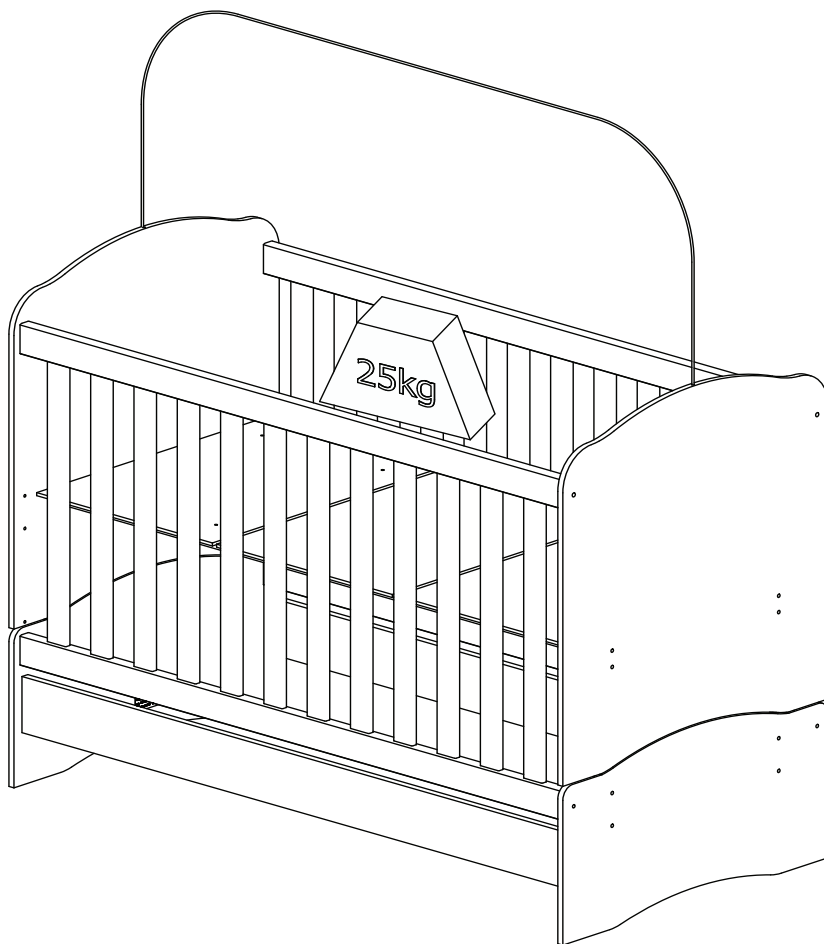

Para o Berço Mini Cama Bala de Menta, os lastros da base não podem ser removidos da travessa estrutural para fins de transporte, armazenamento e/ou alteração de função.

Para la Cuna Mini Cama Bala de Menta, los lostros de la base no pueden ser removidos del travesa estructural para fines de transporte, almacenamiento y / o alteración de función.

For the Mini Mint Bed Cradle, the base ballast can not be removed from the structural beam for transportation, storage and / or function change purposes.

Para a montagem do berço cama, tirar as peças marcadas com "X" e o restante das peças deverão ser utilizadas para a montagem do berço cama.

Para el montaje de la cuna cama, sacar las piezas marcadas con "X" y el resto de las piezas deberán ser utilizadas para el montaje de la cuna cama.

To assemble the crib bed, remove the parts marked with "x" and the remaining parts should be used for assembly it.

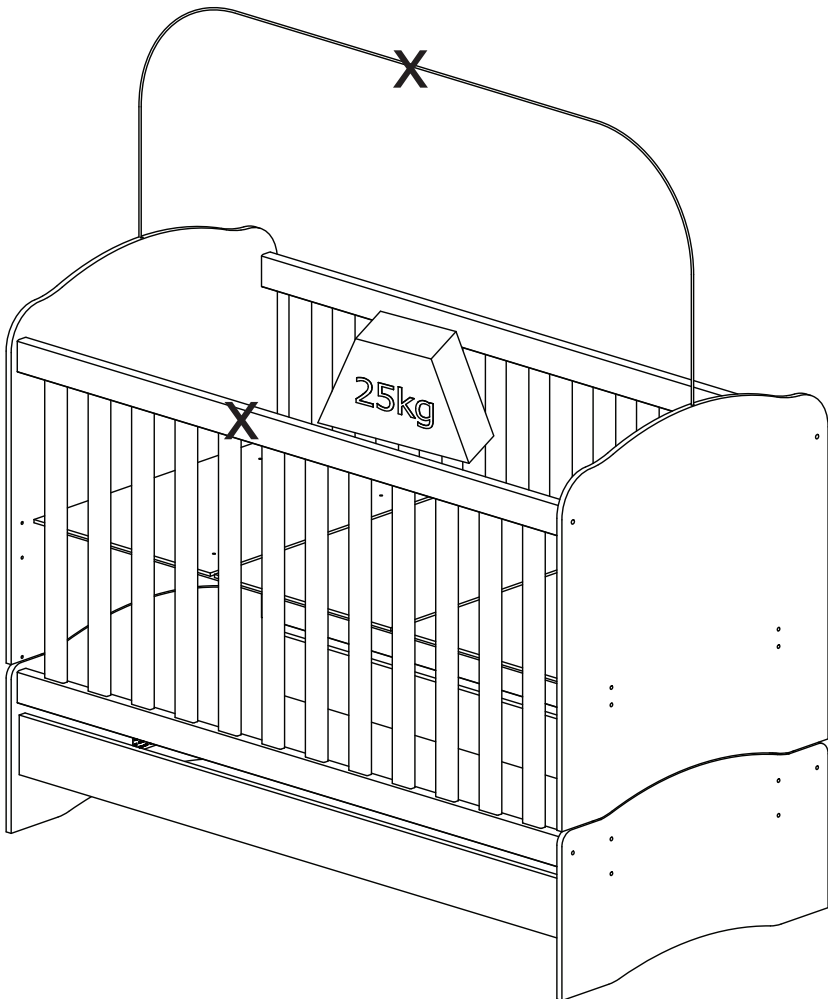

Montagem da opção do berço cama.

Montaje de la opción de la cuna cama.

Mounting the bed crib option.

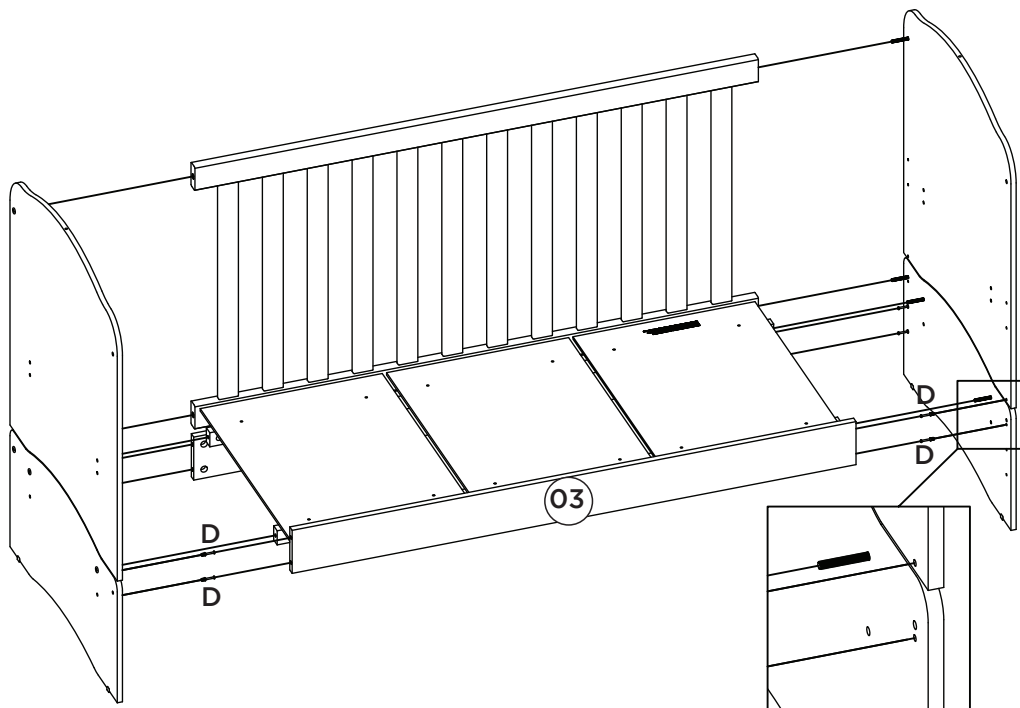

Para a montagem do berço cama a peça (03) deve ser deslocada na parte externa do lastro conforme demonstrado acima.

Para el montaje de la cuna cama la pieza (03) debe ser desplazada en la parte externa del lastre como se muestra arriba.

To install the crib bed the piece (03) must be moved for the outside of the base frame as shown above.

Para a montagem da mini cama, tirar as peças marcadas com "X" e o restante das peças deverão ser utilizadas para a montagem da mini cama.

Para el montaje de la mini cama, sacar las piezas marcadas con "X" y el resto de las piezas deberán ser utilizadas para el montaje de la mini cama.

To assemble the mini bed, remove the parts marked with "X" and the remaining parts should be used to assemble the mini bed.

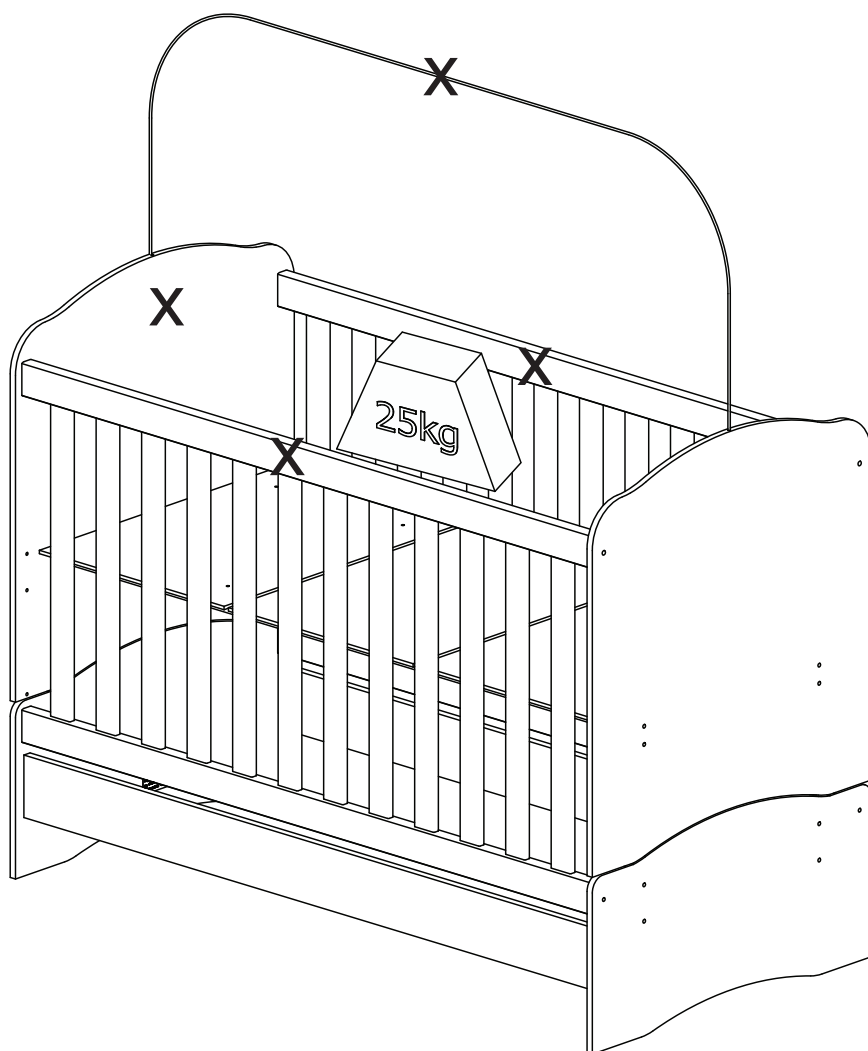

11º

Montagem da opção da mini cama.

ITM/I02-

Montaje de la opción de la mini cama.

Mount the mini bed option.

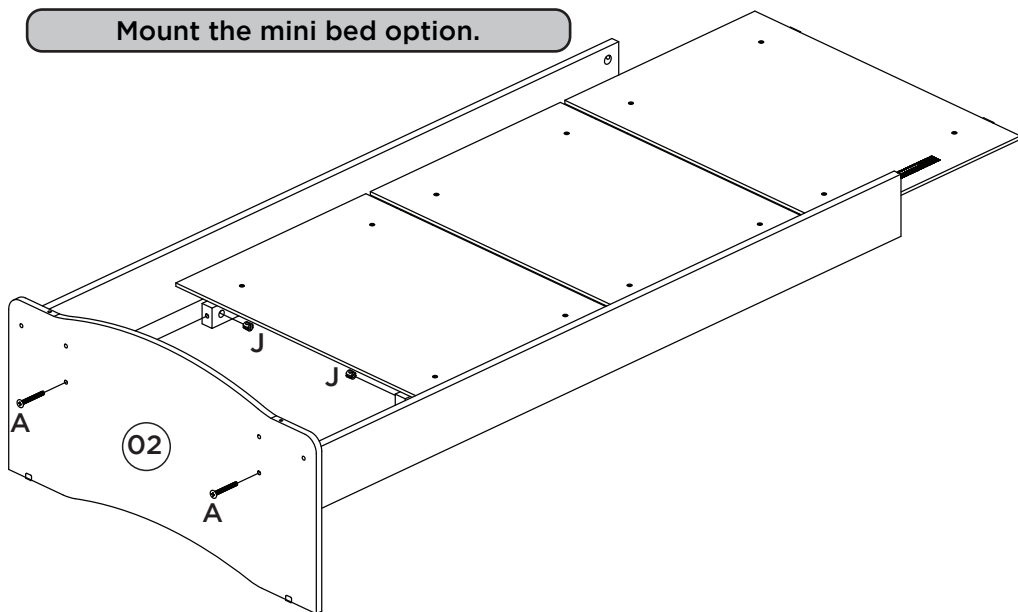

12º

Para a montagem da Mini Cama é necessário utilizar a peça de nº 02 para a montagem da peseira e a peça de nº 06 para a montagem da cabeceira.

Para el montaje de la Mini Cama es necesario utilizar la pieza de nº 02 para el montaje de la peseira y la pieza de nº 06 para el montaje de la cabecera.

To install the Mini Bed it is necessary to use the parts nº 02 for the assembly of the footboard and the parts nº 06 for the assembly of the headboard.

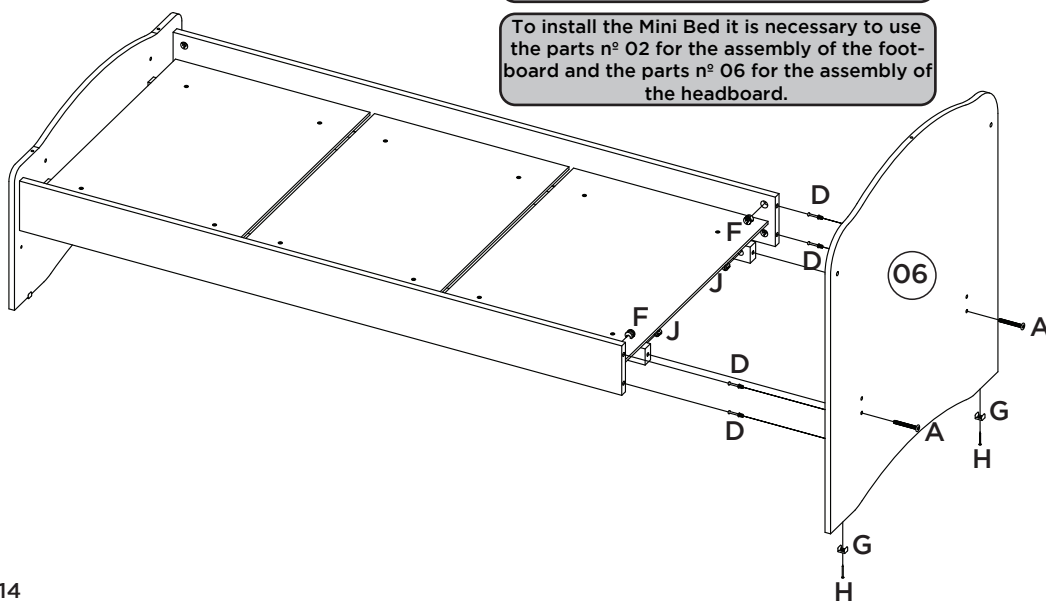

13º

Para fixação da lateral inferior (01) na travessa estrutural (03) deve ser feita as furações.

Para la fijación del lateral inferior (01) en el tramo estructural (03) se deben realizar las perforaciones.

For fixing the lower side (01) on the structural cross member (03) drills must be made.

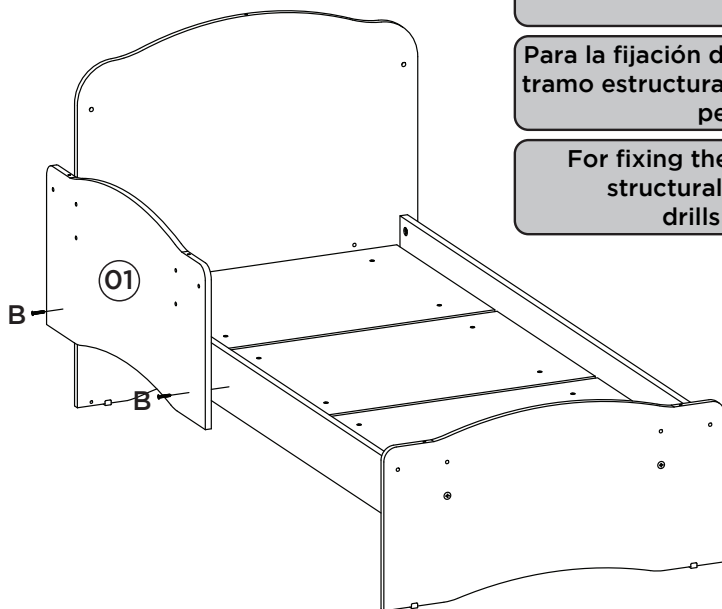

14º

Colocação da cantoneira (I).





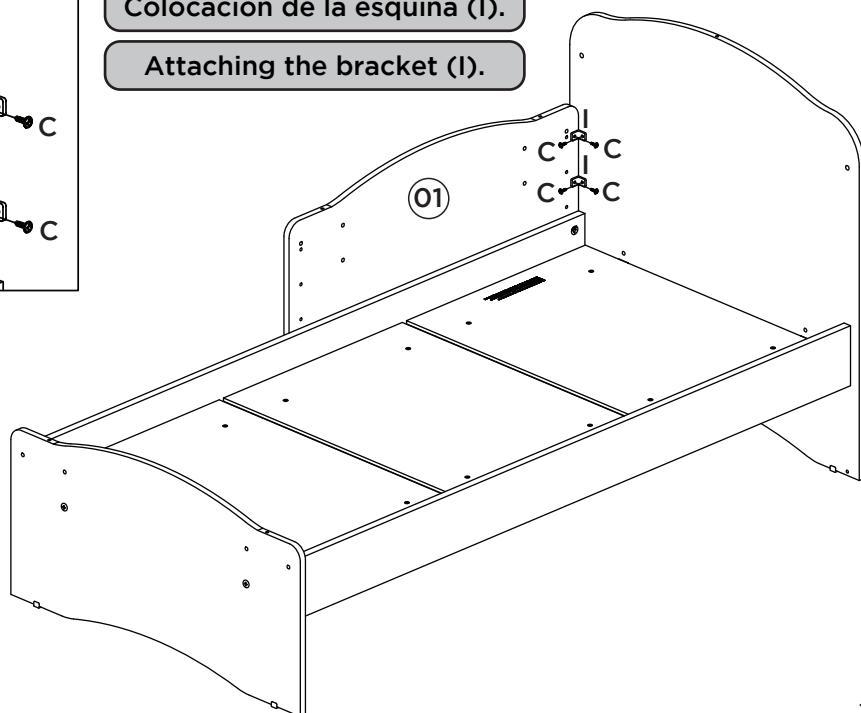
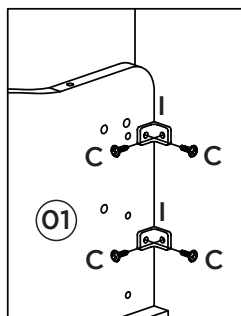



Colocación de la esquina (I).

Attaching the bracket (I).

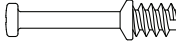

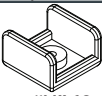
Item	Caixa Caja Box	Qtd Ctd Qty	Descrição Descripción Description	Medidas (mm) Dimensions (mm) Size (measurements) (mm)
01	1/1	01	Lateral inferior Lateral inferior Lateral side	680x340x12
02	1/1	01	Lateral inferior com etiqueta Lateral inferior con etiqueta Lateral side with tag	680x340x12
03	1/1	02	Travessa estrutural Travesaño estrutural Structural Frame	1301x110x15
04=06	1/1	01	Lateral superior Lateral superior Upper Lateral	705x680x12
05=10	1/1	01	Grade fixa Rejilla fija Fixed Rail	1300x670x25
06=04	1/1	01	Lateral superior Lateral superior Upper Lateral	705x680x12
07	1/1	02	Travessa para berço Travesaño para Cuna Crib Frame	1301x36x22
08	1/1	01	Lastro maior 6mm com carimbo Lastre mayor 6mm con sello 6mm Large base Frame with seal	595x420x6
09	1/1	02	Lastro maior 6mm Lastre mayor 6mm 6mm Largest Base Frame	595x420x6
10=05	1/1	01	Grade fixa Rejilla fija Fixed Rail	1300x670x25
11	1/1	01	Suporte mosquitoeiro 1320mm Soporte de mosquiteros 1320mm 1320mm mosquito net support	1320mm

Ferragens | Herrajes | Hardware

A  Parafuso 1/4x50mm PAN. Tornillo 1/4x50mm PAN. Screw 1/4x50mm PAN.	B  Parafuso 4,5x25mm CHT. Tornillo 4,5x25mm CHT. Screw 4,5x25mm CHT.	C  Parafuso 3,5x12mm FLA. Tornillo 3,5x12mm FLA. Screw 3,5x12mm FLA.	D  Parafuso minifix Tornillo minifix Minifix bolt
E  Cavilha 5x60mm Tarugo 5x60mm Dowel 5x60mm	F  Tambor minifix Tambor minifix Minifix nut	G  Sapata "U" 12x15mm Zapata "U" 12x15mm "U" shoe 12x15mm	H  Prego 12x12mm Anelado Clavo 12x12mm Anillado Ringed Nails 12x12mm
I  Cantoneira plástica Cantonera plástica Plastic angle brackets	J  Porca Zamac 12x12 Tuerca Zamac 12x12 Zamac nut 12x12		