

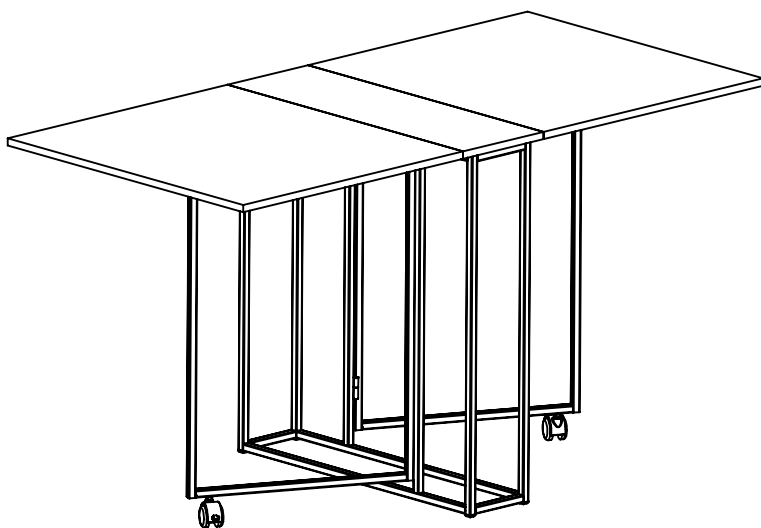





PLACA&PONTO



**P1003 - MESA DOBRÁVEL**

**01**

**LISTA DE FERRAGENS**

REF.	DESCRIÇÃO	VINHETA	QTD.
<b>A</b>	Parafuso C.Chata 3,5x14mm ZA		28
<b>B</b>	Suporte "u"		02
<b>C</b>	Rodizio RD40 HR 1-4" com trava		04
<b>D</b>	Dobradiça 1. 1/2"		04
<b>E</b>	Ponteira plastica 15x15		04

VISTA EXPLODIDA

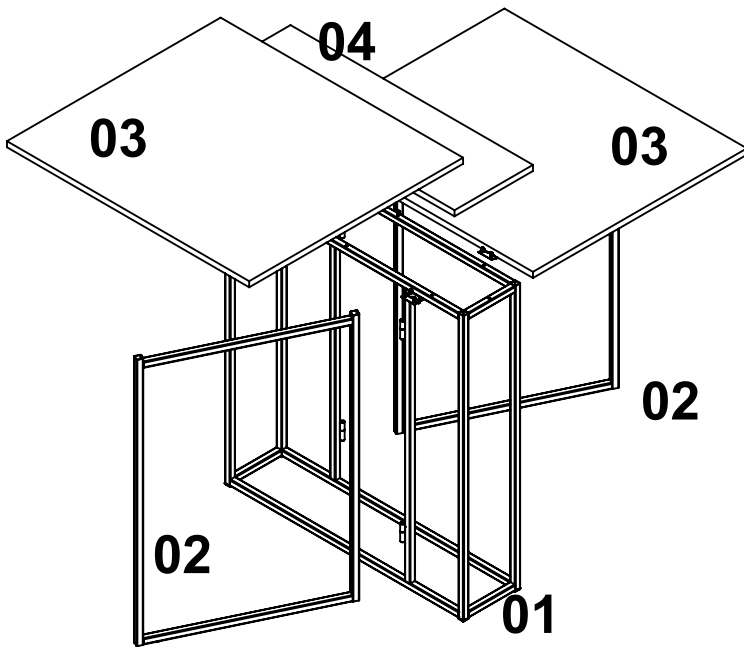

**LISTA DE PEÇAS**

Nº	DESCRIÇÃO	QTD.	DIMENSÕES (mm)		
			COMP.	LARG.	ESP.
01	Estrutura Central/ Centro de Mesa/ Table Center	01	670	740	275
02	Estrutura Mesa/ Estructura Mesa/ Table Structure	02	695	470	15
03	Tampo Maior/ Parte Maior/ Bigger Top	02	680	600	15
04	Tampo Central/ Centro Sup/ Center Top	01	680	220	15

# PLACA&PONTO

01

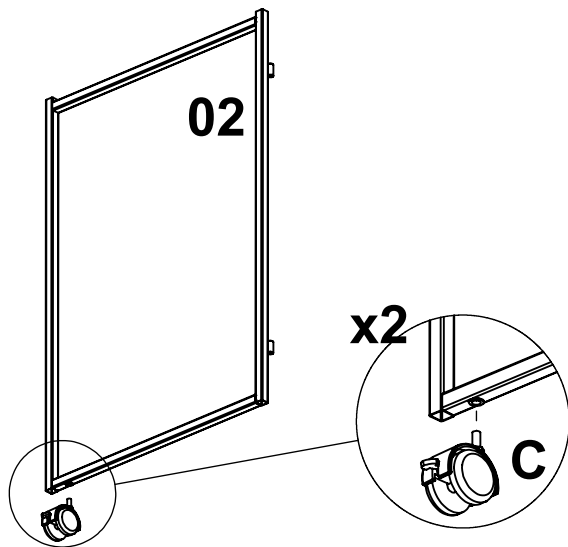

02

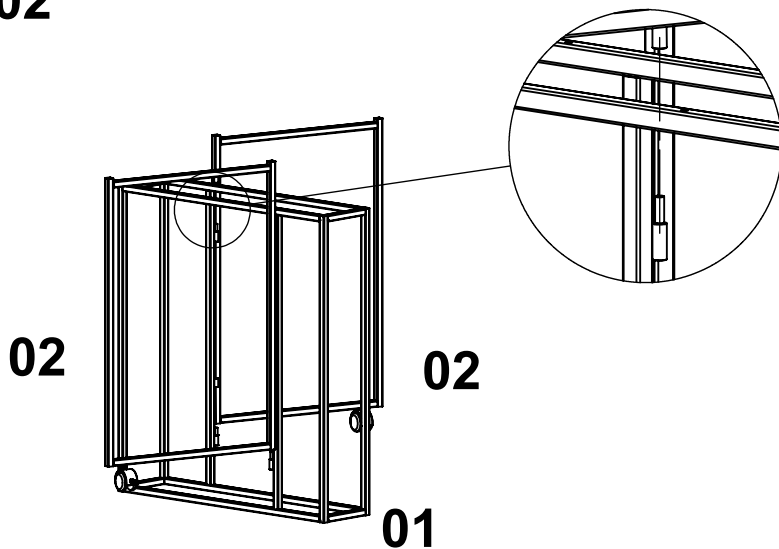

05

# PLACA&PONTO

**03**

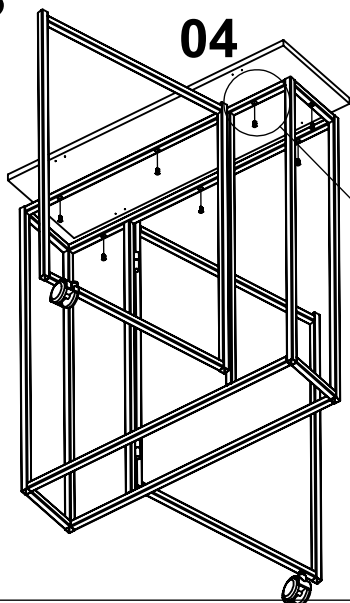

**04**

Lado para Cima

Lado para Baixo

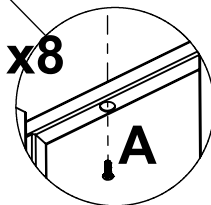

**04**

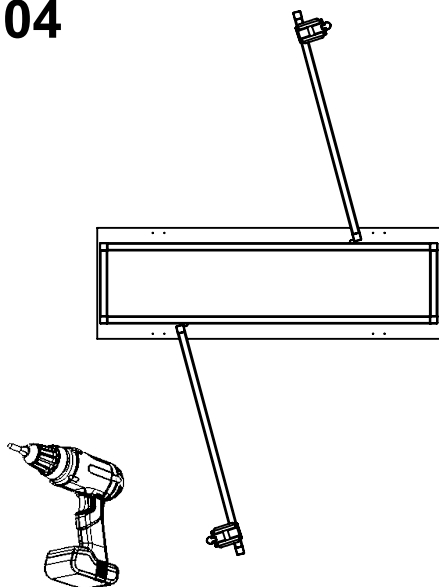

OBS: Centralize o tampo antes de parafusar.  
Monte de cabeça para baixo.

NOTA: Centre la parte superior antes de atornillar.  
Montar al revés.

NOTE: Center the top before screwing.  
Mount upside down.

**06**

# PLACA&PONTO

05

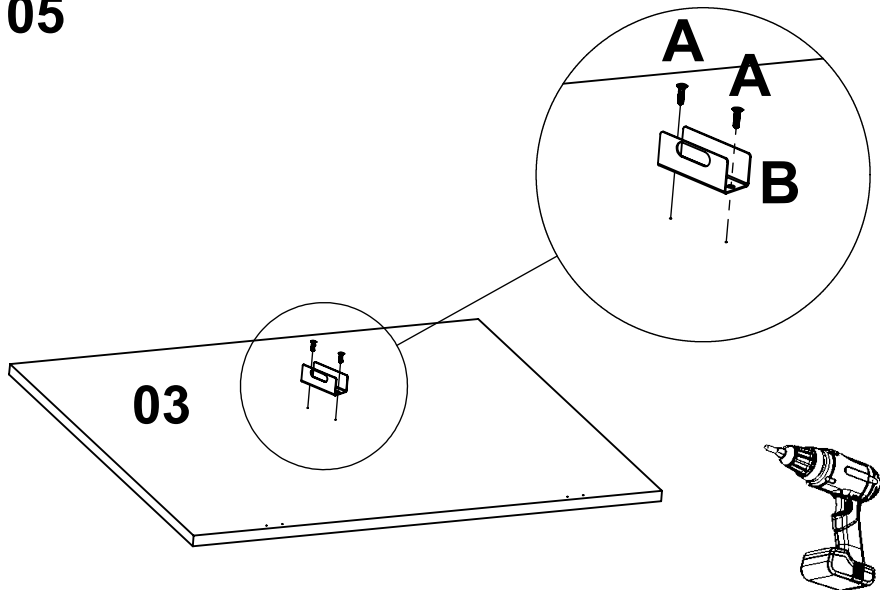

06

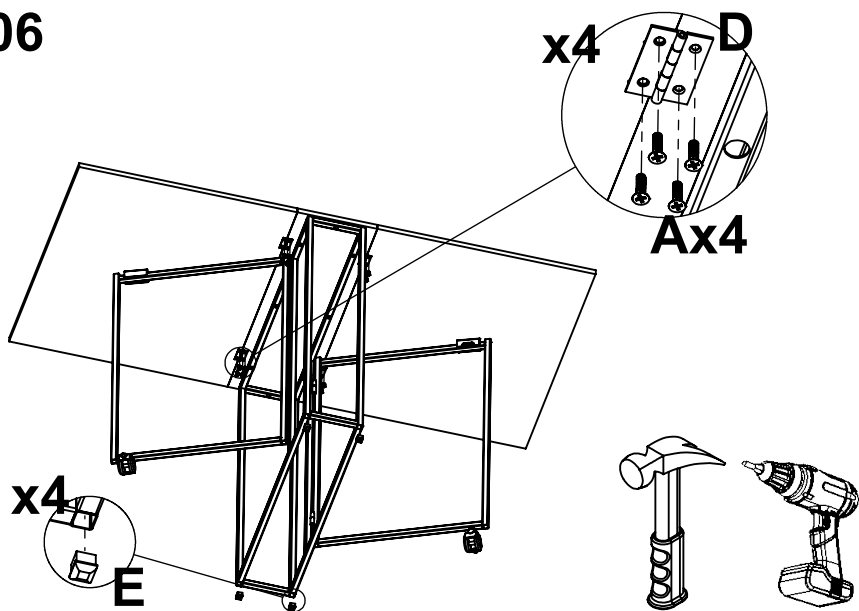

07

07

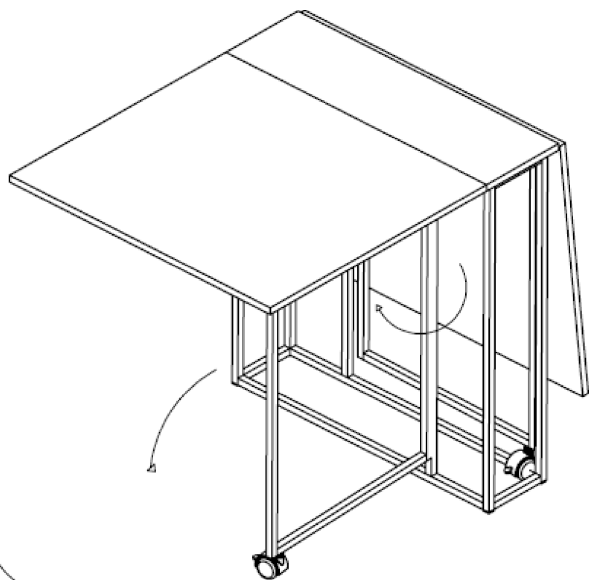

08

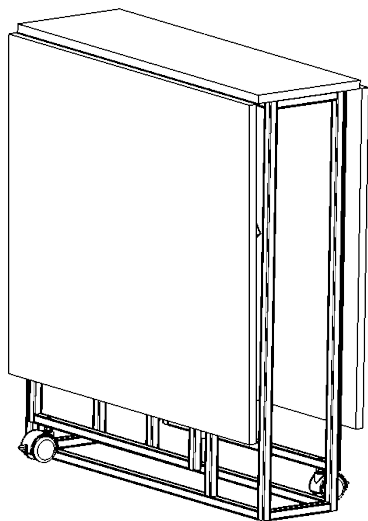

08