

HOME MACEIÓ

V-2 16/03/22

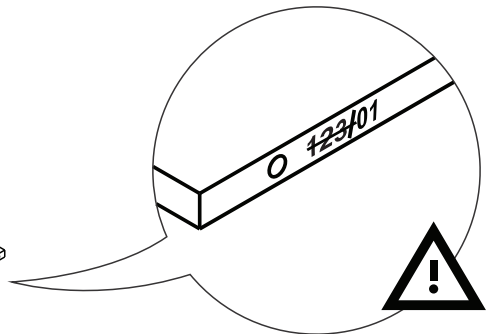
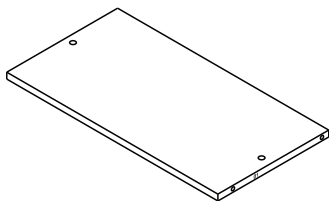
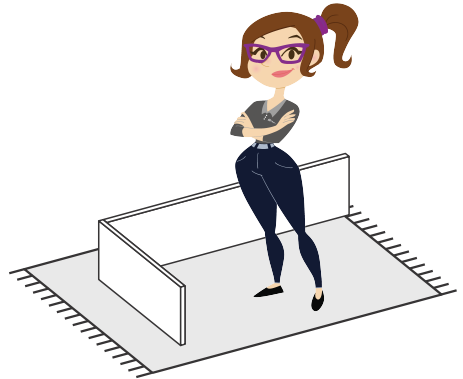
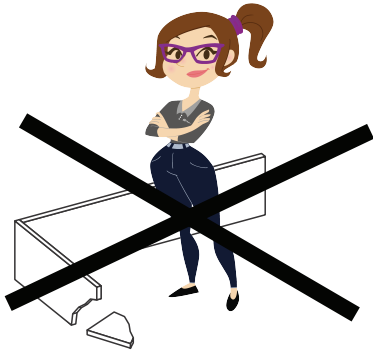
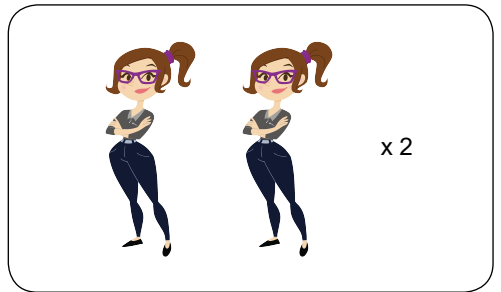
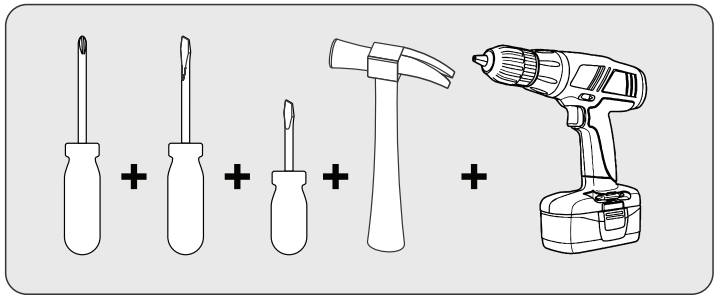
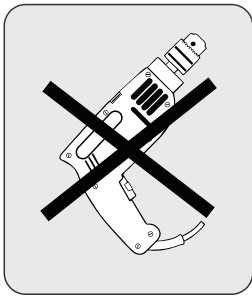

Nossos produtos são garantidos por 90 dias contra defeitos de fabricação. Ao constatar um problema coberto pela garantia, entre em contato com a loja onde o produto foi comprado. Ela estará capacitada para atendê-lo da melhor forma diante de cada caso. Reclamações de garantia somente poderão ser atendidas se o termo de garantia for apresentado no ato de reivindicação, acompanhado de sua nota fiscal de compra.

Nuestros productos están garantidos contra defectos de fabricación por 90 días, a partir de la compra. Ao constatar un problema protegido por la garantía, póngase en contacto con la tienda donde se adquirió el producto. Ella estará capacitada para atenderlo de la mejor manera de acuerdo con cada caso.

Our products are guaranteed against manufacturing defects for 90 days from the date of purchase. When you find a problem covered by the warranty, please contact the store where the product was purchased. The store be able to serve you in the best way in each case.

Exclusões

- Desgaste natural ou danos causados por água, maresia, ferrugem, incêndio, calor, cupins e pragas em geral
- Montagem, manutenção e uso inadequado
- Não cumprimento das recomendações técnicas do esquema
- Montagens e desmontagens após a primeira instalação
- Instalações elétricas e outras afins

Exclusiones

- Desgaste natural o daños causados por agua, maresia, incendios, calor, termitas y plagas en general
- Montaje, mantenimiento y uso inadecuado
- No cumplimiento de las recomendaciones técnicas del esquema
- Montaje y desmontaje después de la primera instalación
- Instalaciones eléctricas y otras afines

Exclusions

- Natural wear or damage caused by water, sea, rust, fire, heat, termites and plagues in general
- Assembly, maintenance and improper use
- Failure to comply with the technical recommendations of the assembly instructions
- Assembly and disassembly after first installation

Importante

A Linha Brasil não autoriza nenhuma pessoa, loja ou entidade assumir em seu nome qualquer outra garantia que não conste no certificado. A fabricante reserva-se no direito de efetuar nos produtos eventuais modificações que considerar necessárias, sem prejudicar as características essenciais. Os produtos terão peças de assistência para reposição no período de 1 ano a contar de sua retirada do mercado, desde que haja matéria-prima equivalente, observando o dispositivo no Art.32 da Lei 8.078/90 (Cód. Defesa do Consumidor). O atendimento para produtos fora de linha é feito por programação especial, através da loja revendedora sob aprovação de consulta prévia ao fabricante.

Importante / Línea Brasil no autoriza a ninguna persona, tienda o entidad a asumir in su nombre cualquier otra garantía que no figure en el certificado. El fabricante se reserva el derecho de efectuar en los productos eventuales modificaciones que considere necesarias, sin perjudicar las características esenciales. Los productos tendrán piezas de asistencia para reposición en el período de 1 año a partir de su retirada del mercado. La atención para productos fuera de línea es hecha por programación especial, a través de la tienda revendedora bajo aprobación de consulta previa al fabricante.

Important / Línea Brasil does not authorize any person, store or entity to assume on its behalf any other warranty that does not appear on the certificate. The manufacturer reserves the right to make in the products any modifications that it considers necessary without prejudice to the essential characteristics. The products will have replacement parts within one year of being withdrawn from the market. The service for off-line products is done by special programming, through the store reseller under prior consultation with the manufacture.

INSTRUÇÕES DE LIMPEZA E CONSERVAÇÃO

CLEAN AND PRESERVATION INSTRUCTURE / INSTRUCCIONES PARA LA LIMPIEZA Y CONSERVACION

Para retirar pó, utilize um pano seco, espanador ou aspirador. Se necessário para uma limpeza mais efetiva, utilize um pano levemente úmido com água. Finalize com uma flanela limpa e seca.

To take dirty, use a dry cloth, duster or vacuum. If necessary to take the dust, use a wet cloth. Finish with a clean and dry flannel.

Para eliminar o pó, utilize um pano seco, mopa ou a aspiradora. Si es necesario para una limpieza más eficaz, con paño ligeramente humedecido con agua. Terminar con un paño limpio y seco.



! IMPORTANTE / IMPORTANT / IMPORTANTE

Não utilize produtos abrasivos como álcool e detergentes, como também esponjas rígidas ou palhas de aço na limpeza dos móveis.

Do not use abrasives such as alcohol and detergent, though soaker also steel wool to clean the furniture.

No use limpiadores abrasivos como alcohol y detergentes, así como esponjas rígidas o lana de acero para limpiar los muebles.



Proteja a superfície do móvel de objetos que transmitam calor ou umidade.

Protect the surface of the furniture against objects that can pass heat and humidity.

Proteja la superficie del mueble de objetos que transmitan calor o humedad.



Evitar o contato de água e produto de limpeza com o rodapé do produto, pois poderá danificá-lo.

Avoid the contact of water and cleaning products with baseboard, cause it should damage your product.

Evitar el contacto con agua y producto de limpieza con el rodapié del producto, pues podrá dañarlo.



Procure sempre utilizar flanela limpa e seca para limpeza.

Try always to use a clean and dry flannel to cleaning.

Busque siempre utilizar franela limpia y seca para la limpieza.



Cuidado com objetos pontiagudos, eles podem arranhar a superfície das portas e tampo.

Take care with sharp objects, they can scratch the door lid surface.

Cuidado con objetos afilados, ellos pueden rayar la superficie de las puertas y la tapa.

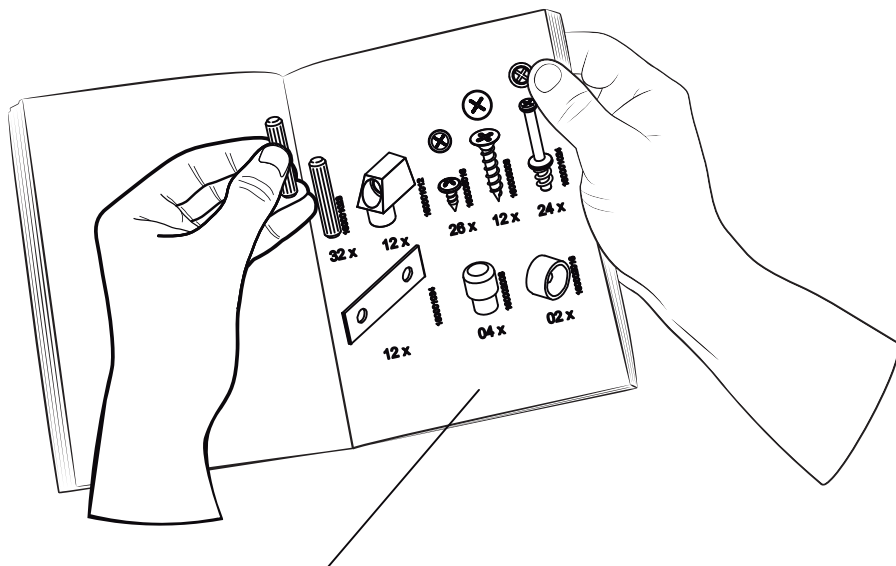

Preste Atenção! ¡Preste atención! Attention!



As ferragens dos nossos manuais são sempre apresentadas nas mesmas proporções da peça na vida real.
Caso apareça alguma dúvida no decorrer do processo de montagem, coloque a ferragem ao lado do desenho e faça a consulta :D

Los accesorios de nuestros manuales siempre se presentan en las mismas proporciones que la pieza en la vida real.
Si tiene alguna duda durante el proceso de montaje, coloque los accesorios junto al dibujo y haga una consulta :D

The accessories in our manuals are always presented in the same proportions as the spare part in real life.
If you have any questions during the assembly process, place the accessory next to the drawing and make an inquiry :D

Símbolos: Simbolos: Symbols:



- + Parafuso Phillips
- Parafuso Fenda
- ⬡ Parafuso Allen

- + Tornillo Phillips
- Tornillo Ranurado
- ⬡ Tornillo Allen

- + Phillips screw
- Slotted Screw
- ⬡ Allen screw

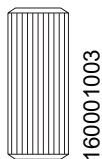

160001003

10 x

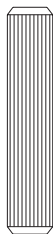

160001023

49 x

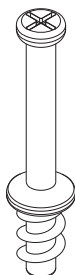

160001024

73 x

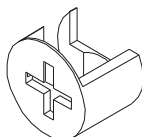

160001025

73 x

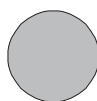

160002022

12 x

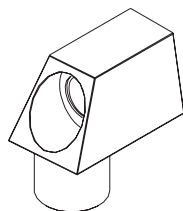

160001012

10 x

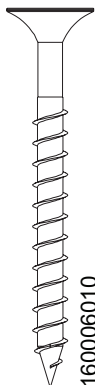

160006010

08 x



160006006

33 x

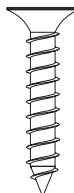

160006008

57 x



160006001

16 x



160006016

234 x



160006002

19 x

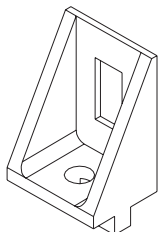

160001011

15 x



160001022

04 x



160006044

04 x



160006011

74 x



160002015

04 x

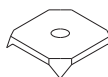

160001002

06 x



160002002

22 x

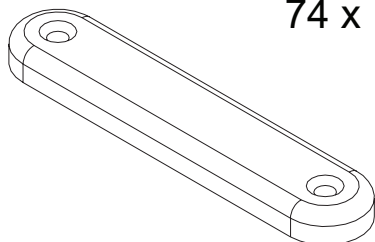

160002004

08 x

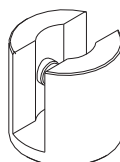

160004001

04 x

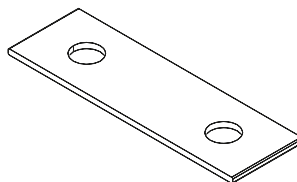

160001034

30 x

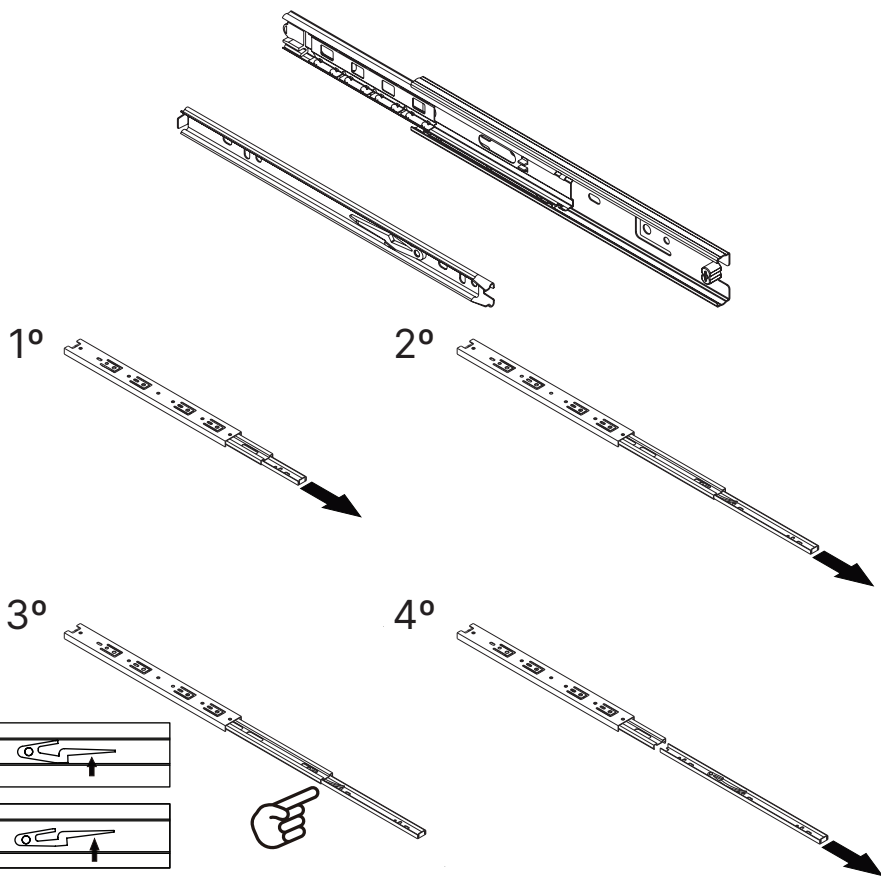
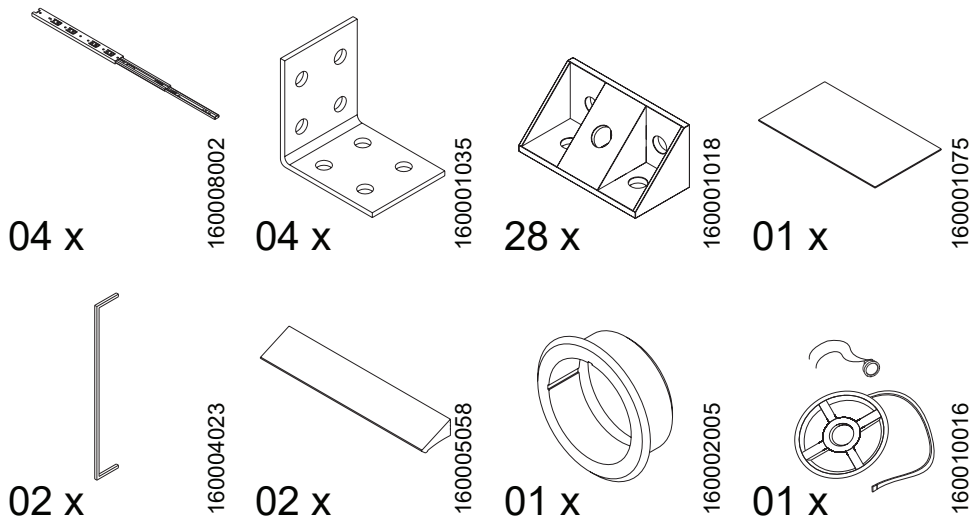

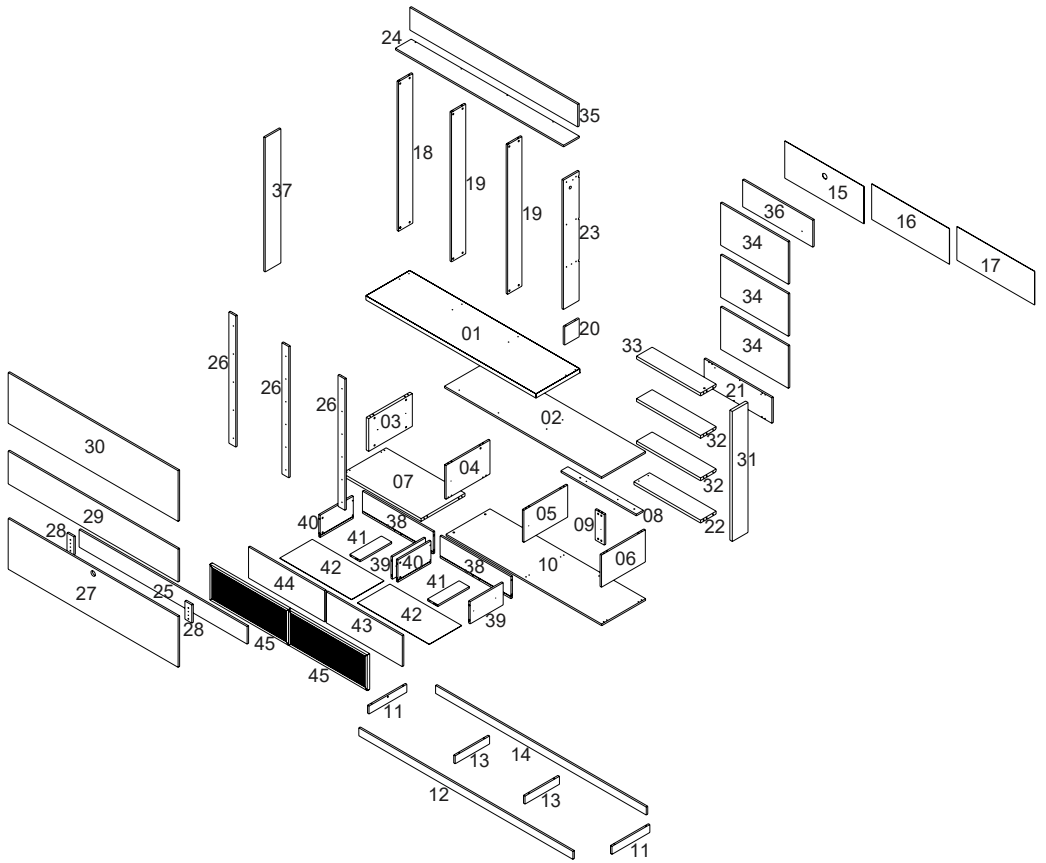

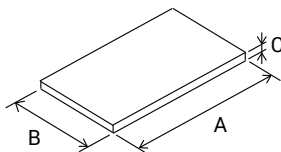

VOLUME Caja Box	ITEM Artículo Item	PEÇA Pieza Part	DESCRIÇÃO Descrição Description	DIMENSÕES (mm) Dimensión/Dimension			QUANTIDADE La Cantidad The Amount	MATERIAL
				A	B	C		
4	1	510236001	TAMPO TV	1730	445	37	1	MDP
3	2	510236002	TAMPO DIREITO	1599	448	15	1	MDP
1	3	510236003	LATERAL ESQUERDA	443	288	25	1	MDP
2	4	510236004	DIVISÃO ESQUERDA	447	298	15	1	MDP
1	5	510236005	DIVISAO CENTRAL	445	283	15	1	MDP
4	6	510236006	LATERAL DIREITA	445	283	15	1	MDP
3	7	510236007	BASE ESQUERDA	803	445	25	1	MDP
1	8	510236008	APOIO FUNDO	767	70	15	1	MDP
4	9	510236009	APOIO TAMPO	268	92	15	1	MDP
3	10	510236010	BASE DIREITA	1583	446	15	1	MDP
1	11	510236011	RODAPE LATERAL	384	70	15	2	MDP
2	12	510236012	RODAPE FRONTAL	2178	70	15	1	MDP
2	13	510236013	RODAPE CENTRAL	350	70	15	2	MDP
2	14	510236014	RODAPE TRASEIRO	2143	70	15	1	MDP
4	15	510236015	FUNDO ESQUERDO COM FURO	805	328	2,8	1	MDF
4	16	510236016	FUNDO CENTRAL	789	313	2,8	1	MDF
4	17	510236017	FUNDO DIREITO	790	296	2,8	1	MDF
2	18	510236018	TRAVESSA LATERAL ESQUERDA	1317	145	15	1	MDP
1	19	510236019	TRAVESSA CENTRAL	1317	145	15	2	MDP
1	20	510236020	TRAVESSA LATERAL INFERIOR DIREITA	154	145	15	1	MDP
2	21	510236021	PAINEL INFERIOR NICHU	689	224	15	1	MDP
1	22	510236022	BASE NICHU	678	159	25	1	MDP
2	23	510236023	TRAVESSA DIREITA	1138	160	15	1	MDP
1	24	510236024	TRAVESSA SUPERIOR	1709	160	15	1	MDP
1	25	510236025	PAINEL INFERIOR	1711	154	15	1	MDP
1	26	510236026	TRAVESSA APOIO	1155	70	15	3	MDP
1	27	510236027	PAINEL INFERIOR TV	1734	447	15	1	MDP
1	28	510236028	TRAVESSA INFERIOR PAINEL	160	70	15	2	MDP
1	29	510236029	PAINEL CENTRAL TV	1734	290	15	1	MDP
2	30	510236030	PAINEL SUPERIOR TV	1734	447	15	1	MDP
1	31	510236031	LATERAL DIREITA NICHU	1147	160	25	1	MDF
1	32	510236032	PRATELEIRA NICHU	650	158	25	2	MDF
1	33	510236033	TAMPO NICHU	650	158	25	1	MDF
2	34	510236034	PAINEL CENTRAL NICHU	689	373	15	3	MDP
1	35	510236035	PAINEL SUPERIOR ESQUERDO	1705	199	15	1	MDP
2	36	510236036	PAINEL SUPERIOR DIREITO	714	238	15	1	MDP
1	37	510236037	ACABAMENTO LATERAL	1181	159	15	1	MDP
2	38	510236038	CONTRA FUNDO GAVETA	720	194	15	2	MDP
3	39	510236039	LATERAL DIREITA GAVETA	336	196	15	2	MDP
4	40	510236040	LATERAL ESQUERDA GAVETA	336	196	15	2	MDP
4	41	510236041	TRAVA DA GAVETA	321	104	15	2	MDP
4	42	510236042	FUNDO GAVETA	730	330	2,8	2	MDF
2	43	510236043	CONTRA FRENTE GAVETA DIREITA	771	273	15	1	MDP
4	44	510236044	CONTRA FRENTE GAVETA ESQUERDA	771	273	15	1	MDP
3	45	510236045	FRENTE DE GAVETA	798	316	25	2	MDF

ARTÍCULO	DESCRIPCIÓN
1	BASE
2	BASE DERECHA
3	LATERAL IZQUIERDA
4	DIVISIÓN IZQUIERDA
5	DIVISIÓN CENTRAL
6	LATERAL DERECHA
7	BASE IZQUIERDA
8	APOYO DE FONDOS
9	APOYO BASE
10	BASE DERECHA
11	ZOCALO LATERAL
12	ZOCALO FRONTAL
13	ZOCALO CENTRAL
14	ZOCALO TRASERO
15	FONDO IZQUIERDO CON AGUJERO
16	FONDO CENTRAL
17	FONDO DERECHO
18	DIVISIÓN LATERAL EZQUIERDA
19	DIVISIÓN CENTRAL
20	DIVISIÓN LATERAL INFERIOR DERECHA
21	PANEL INFERIOR DEL NICHOS
22	BASE DEL NICHOS
23	DIVISIÓN DERECHA
24	DIVISIÓN SUPERIOR
25	PANEL INFERIOR
26	DIVISIÓN APOYO
27	PANEL INFERIOR TV
28	DIVISIÓN INFERIOR TV
29	PANEL CENTRAL TV
30	PANEL SUPERIOR TV
31	LATERAL DERECHA DEL NICHOS
32	ESTANTE DEL NICHOS
33	BASE DEL NICHOS
34	PANEL CENTRAL DEL NICHOS
35	PANEL SUPERIOR IZQUIERDO
36	PANEL SUPERIOR DERECHO
37	ACABADO LATERAL
38	FONDO CAJÓN
39	LATERAL DERECHA DEL CAJÓN
40	LATERAL IZQUIERDA DEL CAJÓN
41	APOYO DEL CAJÓN
42	FONDO DEL CAJÓN
43	FRENTE DERECHA DEL CAJÓN
44	FRENTE IZQUIERDA DEL CAJÓN
45	FRENTE DEL CAJÓN

ITEM	DESCRIPTION
1	BASE
2	LEFT BASE
3	LEFT SIDE
4	LEFT DIVISION
5	CENTRAL DIVISION
6	RIGHT SIDE
7	LEFT BASE
8	FUND SUPPORT
9	BASE SUPORT
10	RIGHT BASE
11	SIDE BASEBOARD
12	FRONTAL BASEBOARD
13	CENTRAL BASEBOARD
14	BACK BASEBOARD
15	LEFT BOTTOM WITH HOLE
16	CENTRAL BACK
17	RIGHT BACK
18	LEFT SIDE DIVISION
19	CENTRAL DIVISION
20	RIGHT SIDE LOWER DIVISION
21	NICHE BOTTOM PANEL
22	NICHE BASE
23	RIGHT DIVISION
24	UPPER DIVISION
25	LOWER PANEL
26	SUPPORT DIVISION
27	LOWER TV PANEL
28	LOWER TV DIVISION
29	CENTRAL TV PANEL
30	UPPER TV PANEL
31	RIGHT SIDE NICHE
32	NICHE SHELF
33	NICHE BASE
34	NICHE CENTER PANEL
35	LEFT UPPER PANEL
36	RIGHT UPPER PANEL
37	SIDE FINISH
38	DRAWER BACK
39	RIGHT SIDE DRAWER
40	LEFT SIDE DRAWER
41	DRAWER SUPPORT
42	DRAWER BACK
43	RIHT DRAWER FRONT
44	LEFT DRAWER FRONT
45	DRAWER FRONT

1

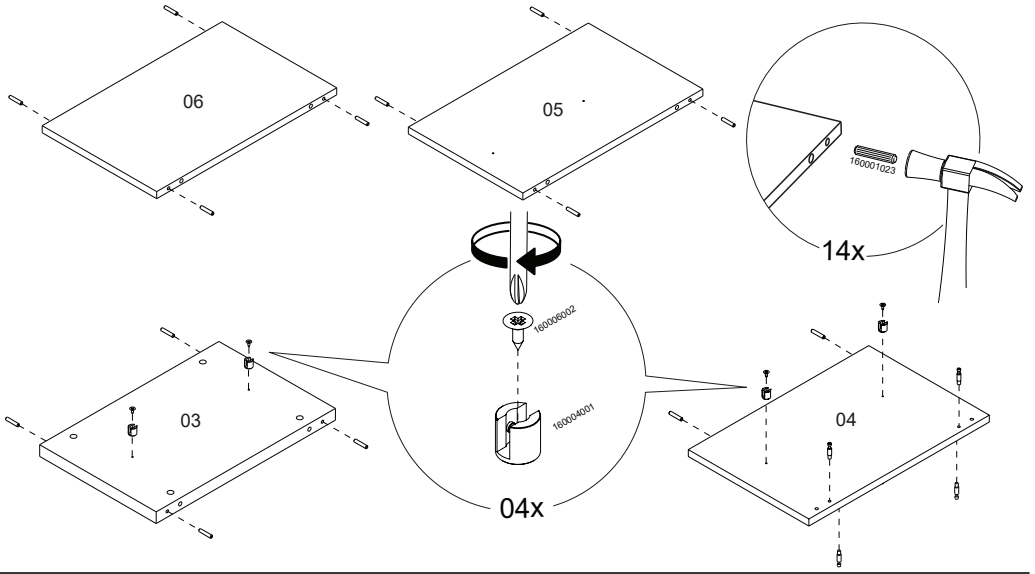
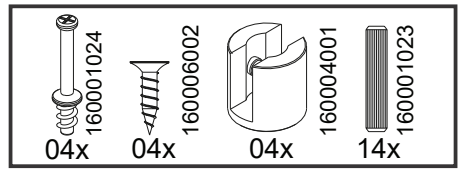

2

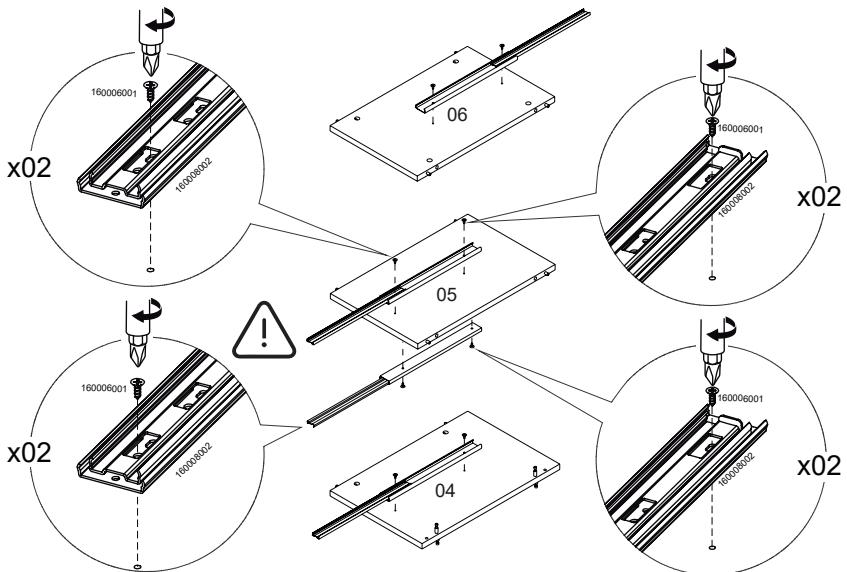
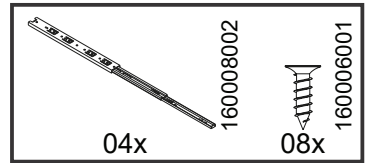

3

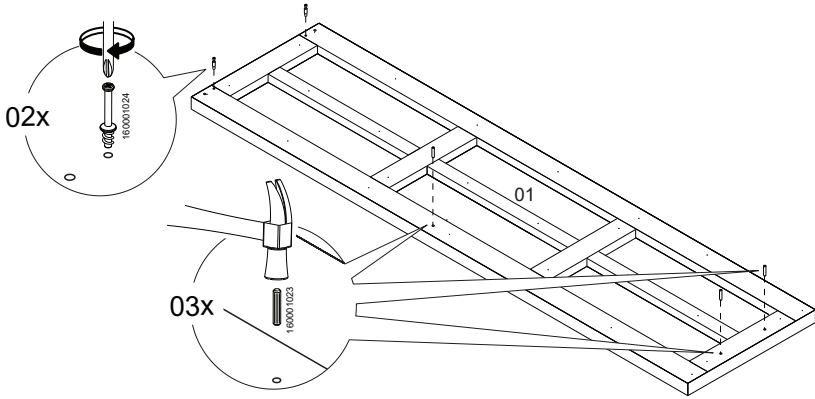
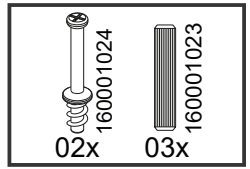

4

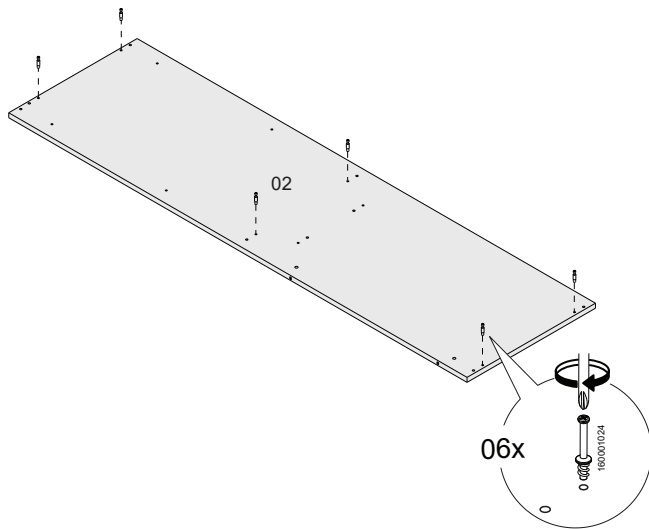
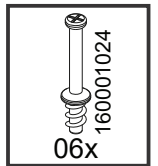

5

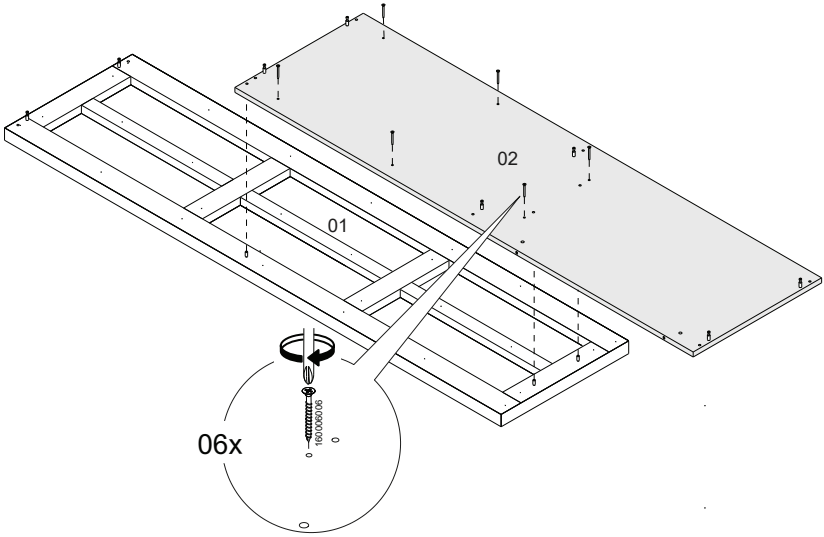
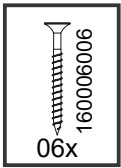

6

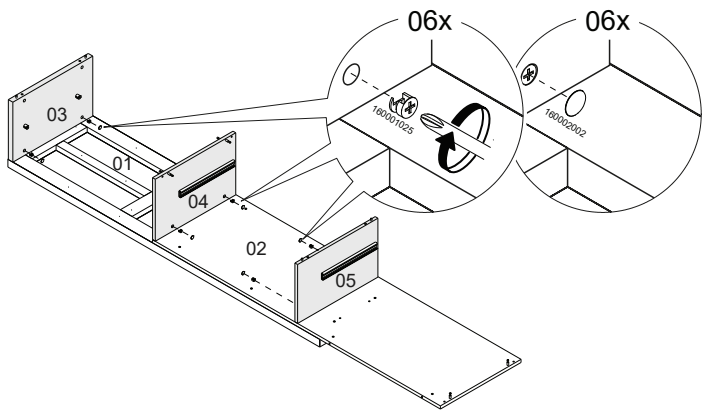
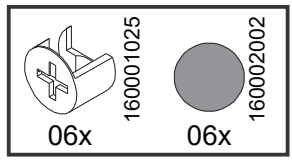
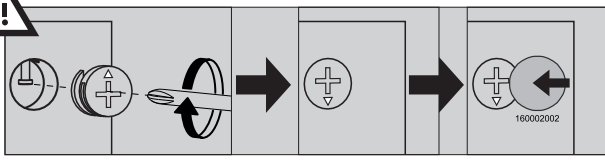

7

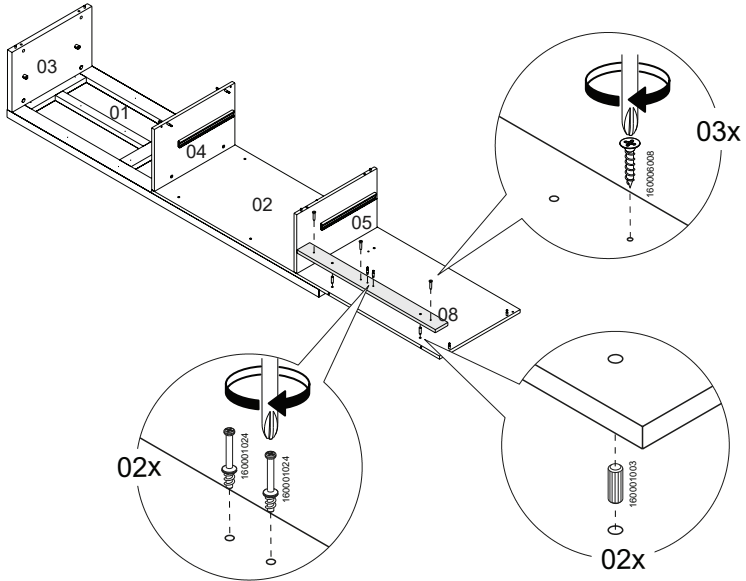
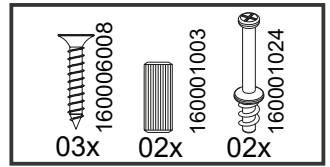

8

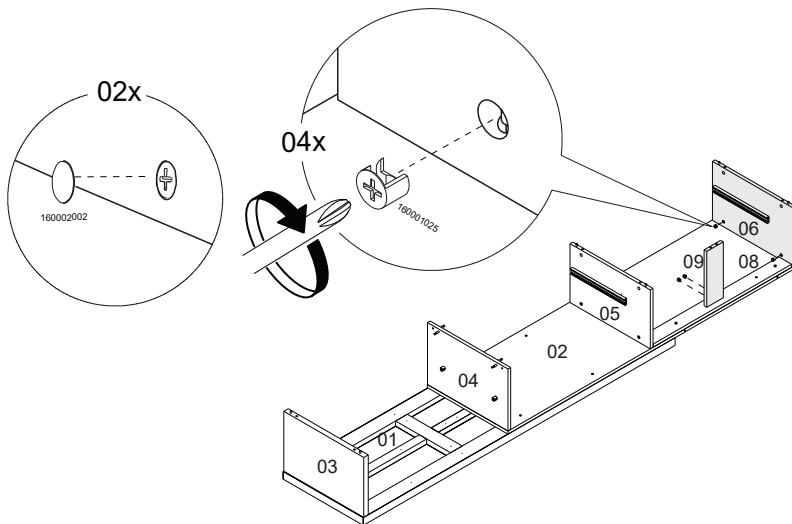
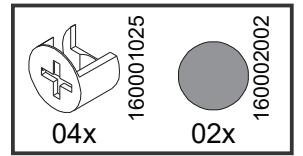
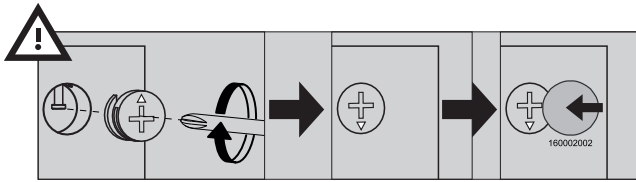

9

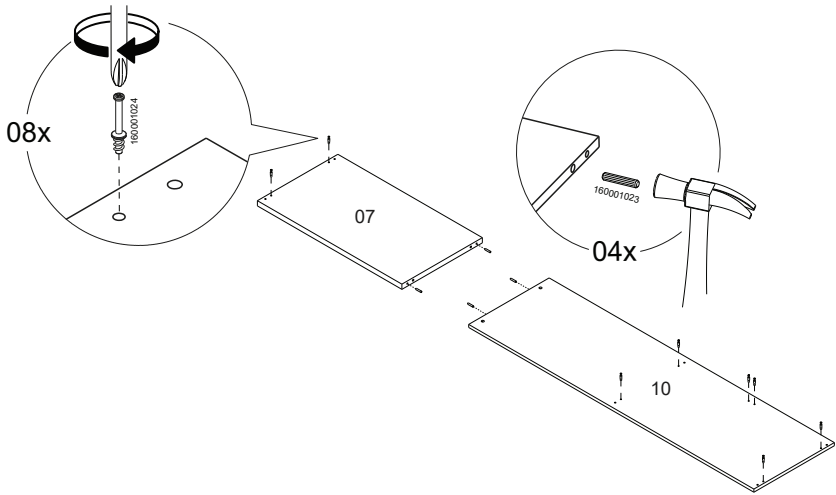
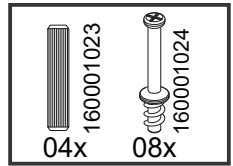

10

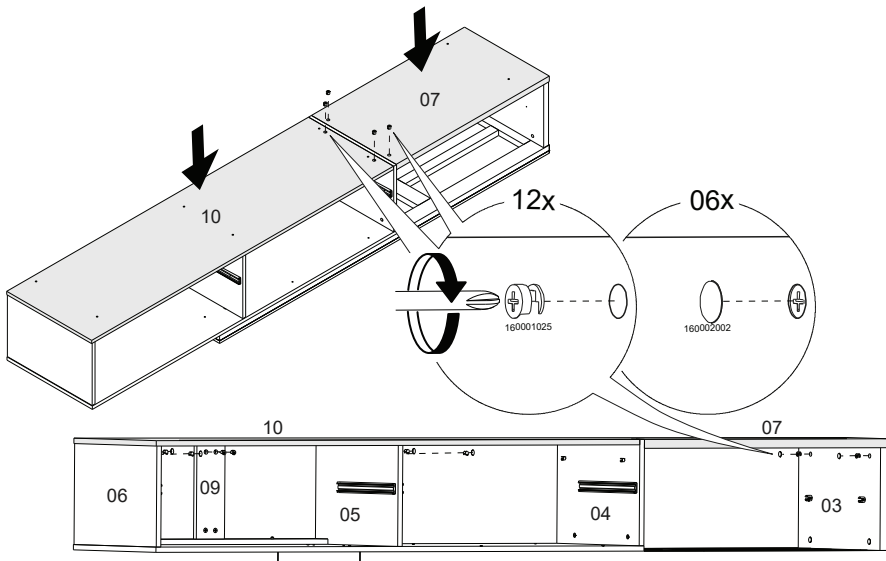
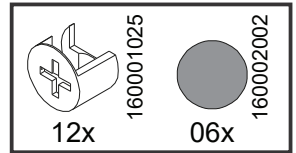
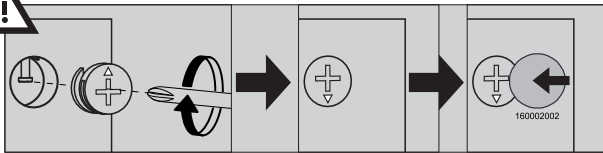

11

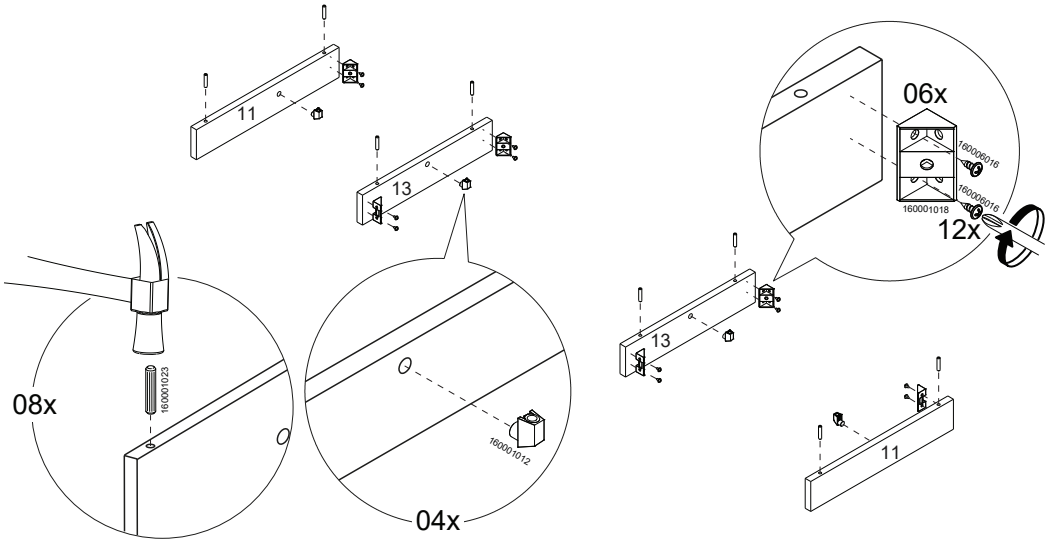
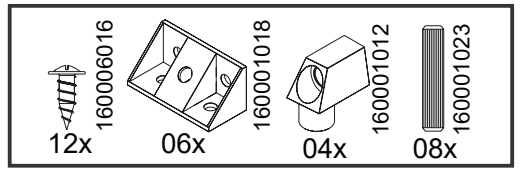

12

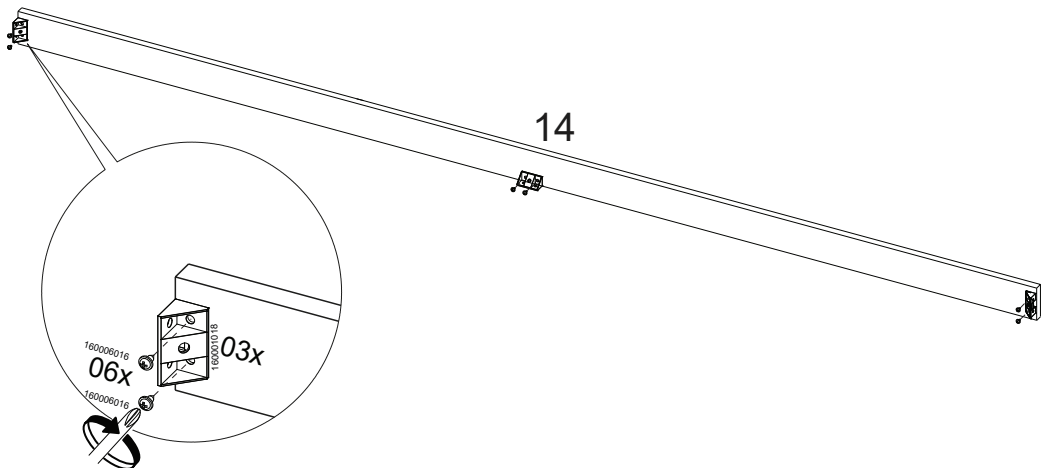
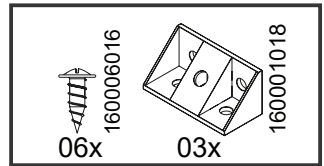

13

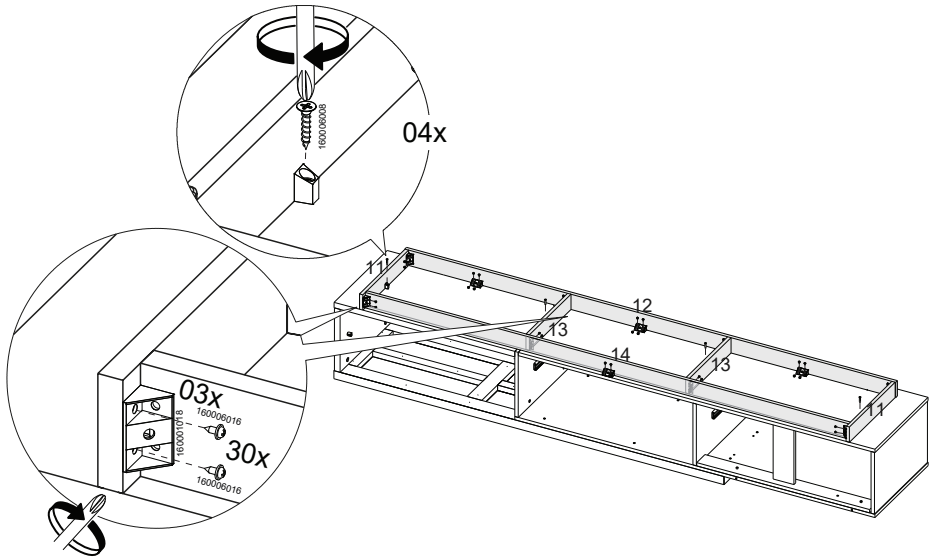
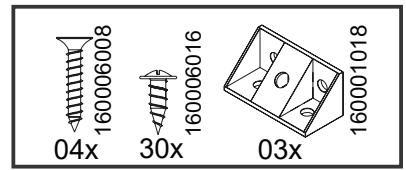

14

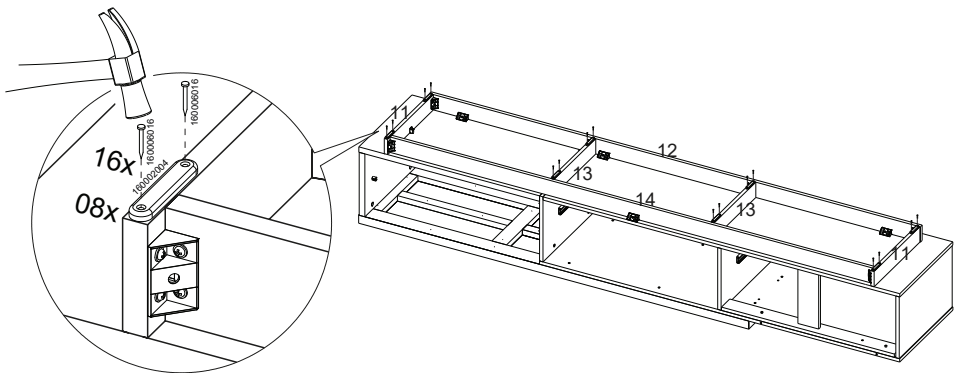
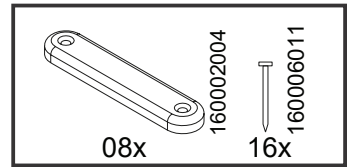

15

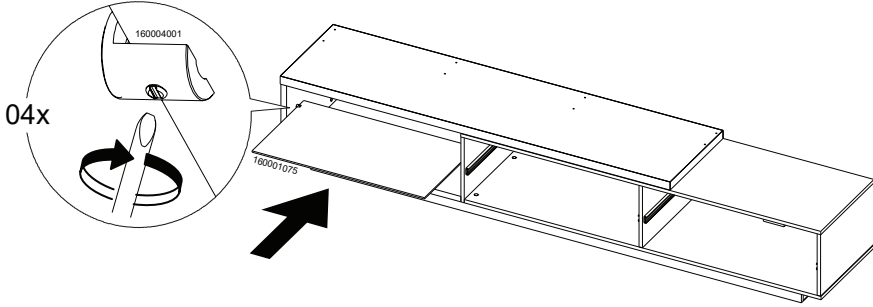
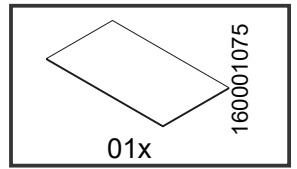

16

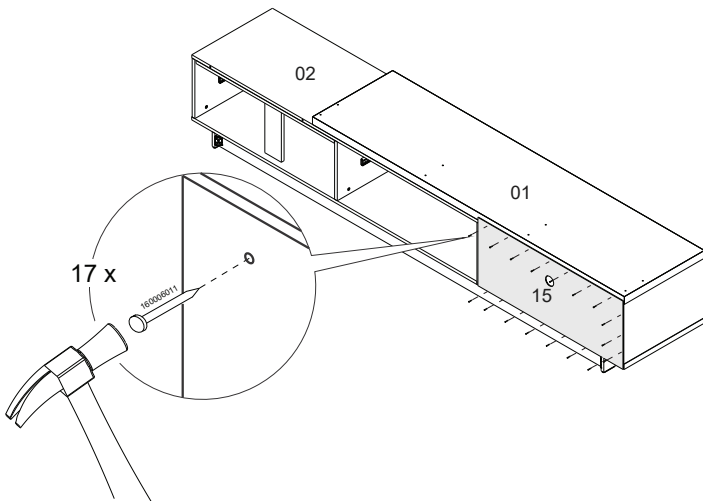
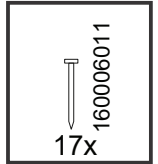

17

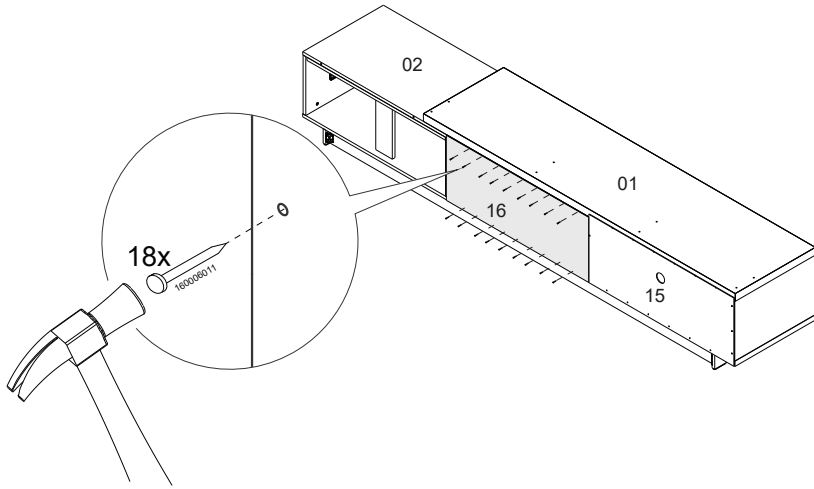
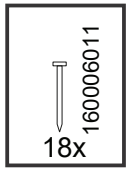

18

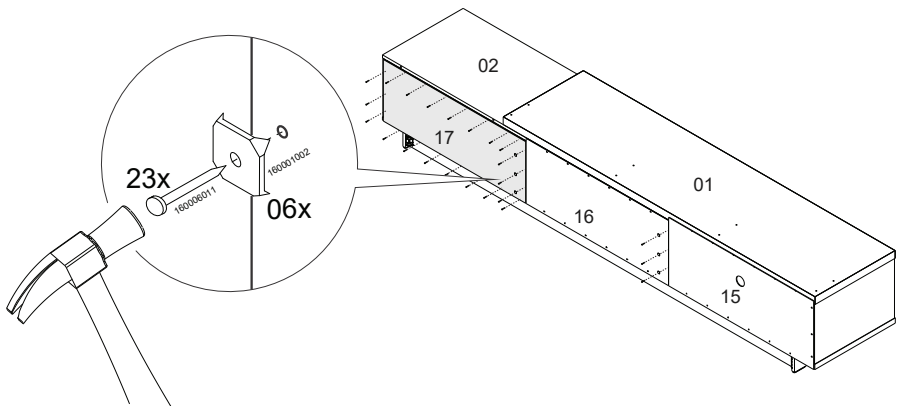
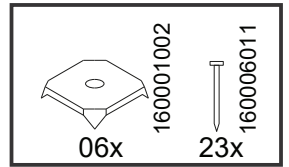

19

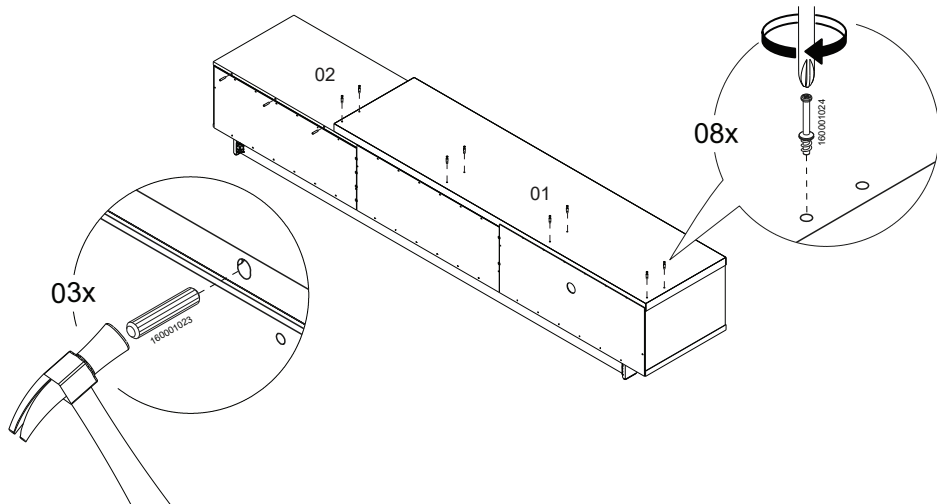
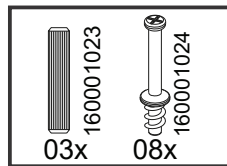

20

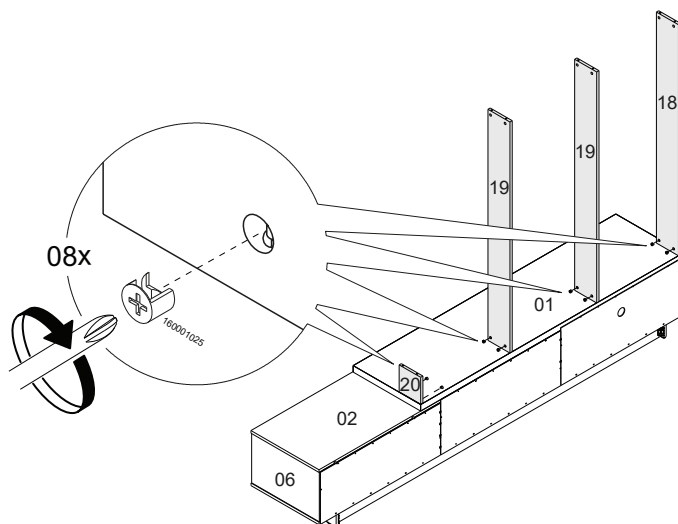
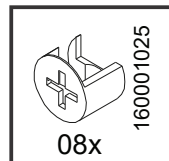
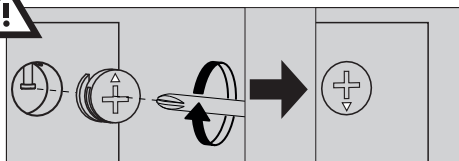

21

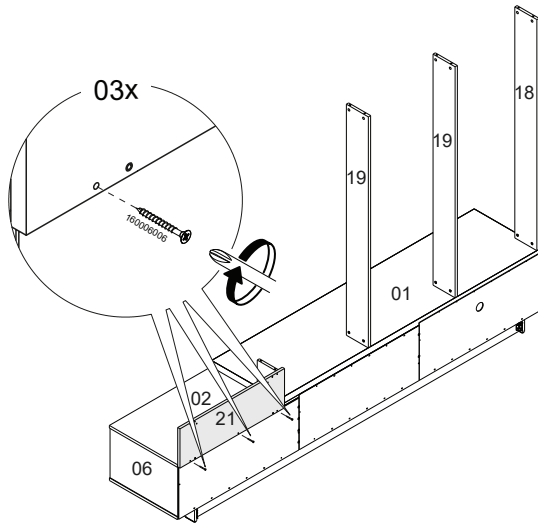
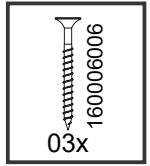

22

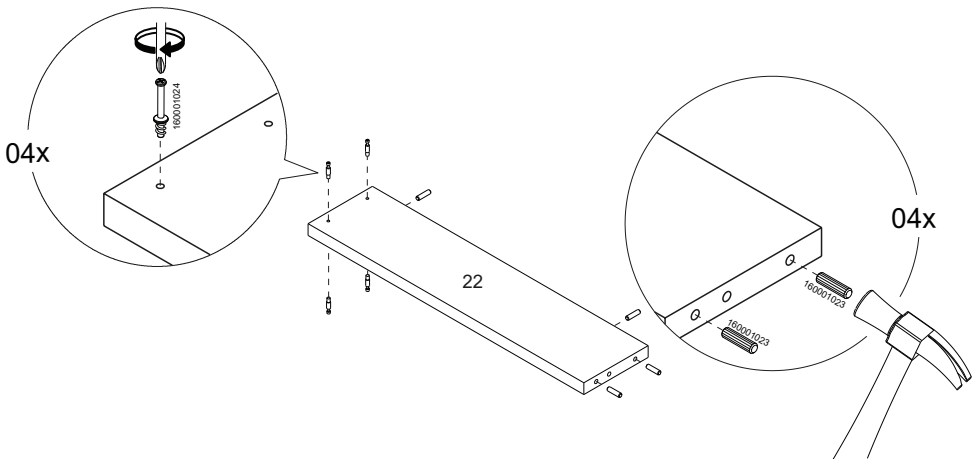
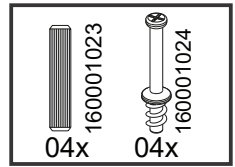

23

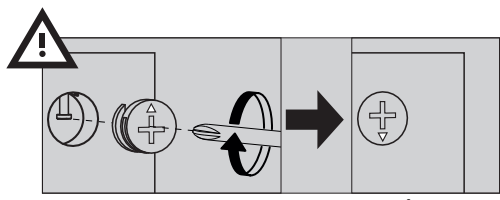

	160001025		160006006
02x		03x	

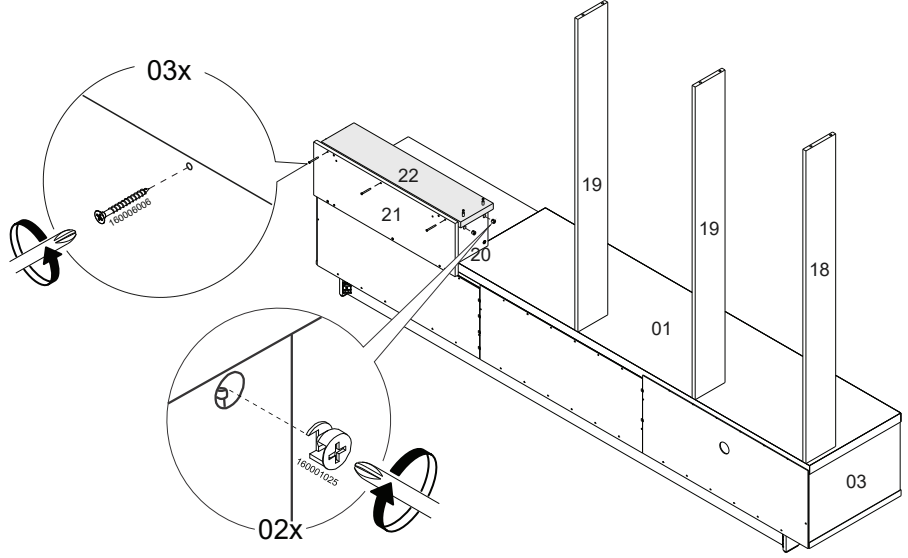

24

	160001023		160001012		160001024
02x		06x		08x	

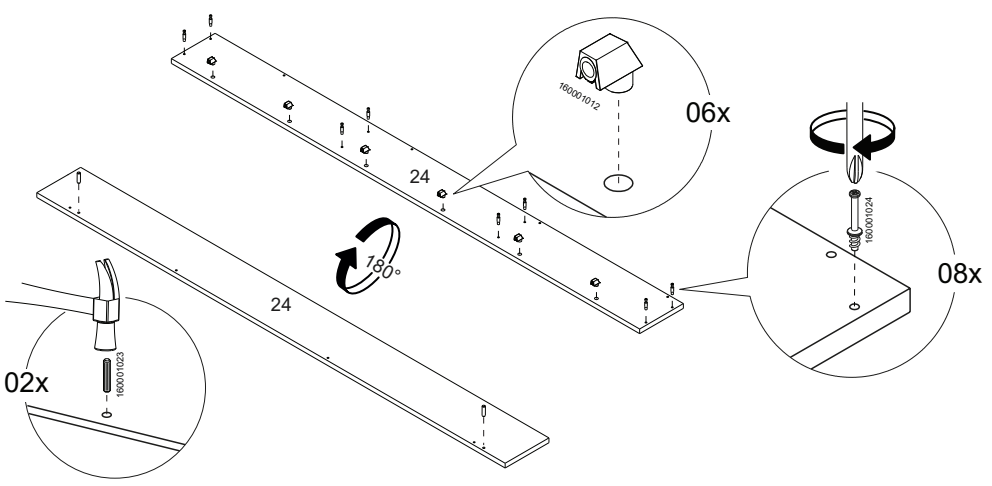

25

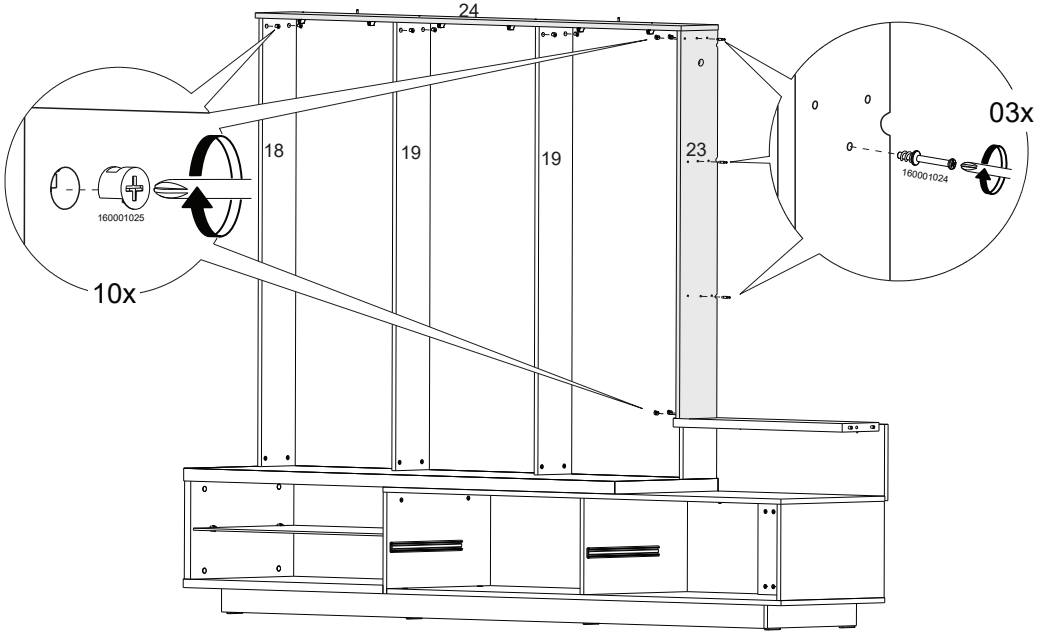
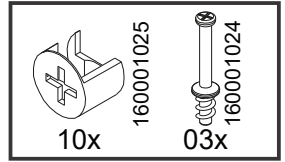
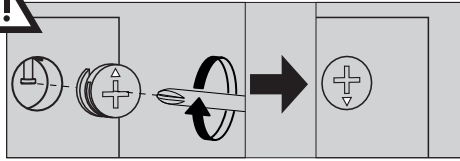

26

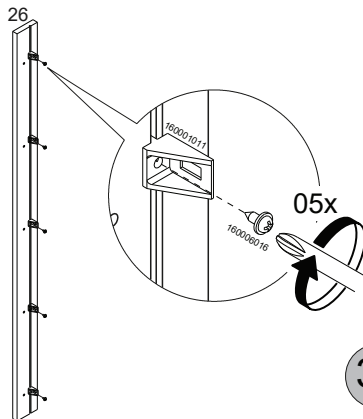
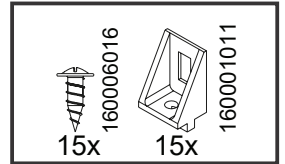

27

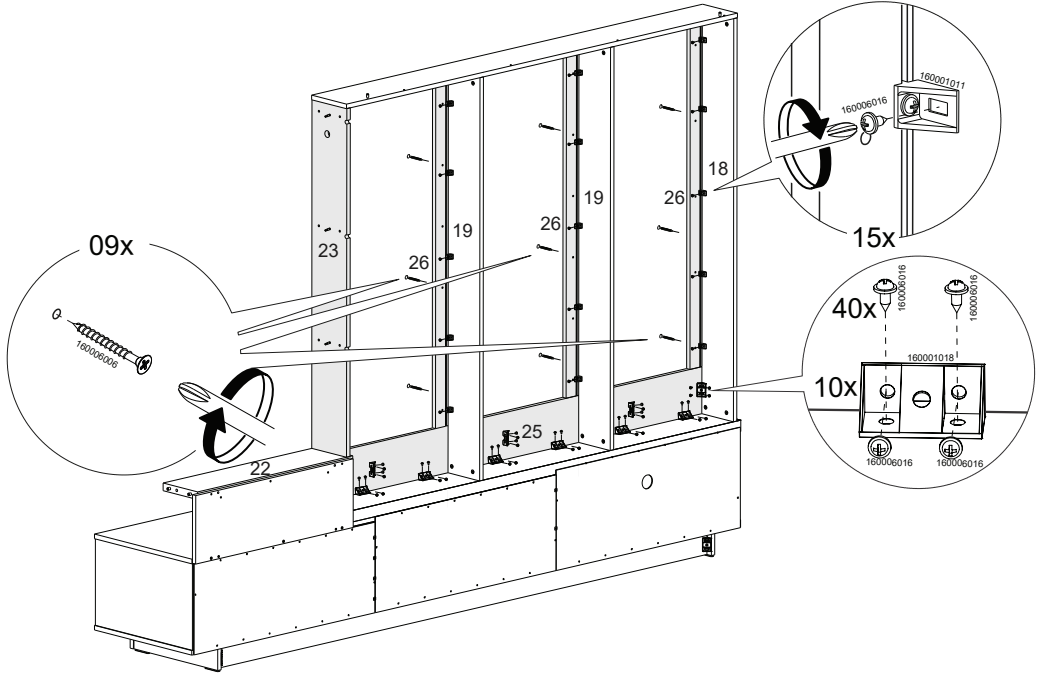
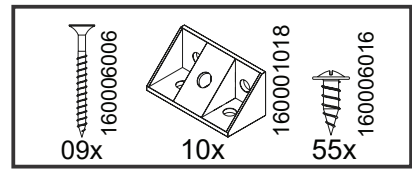

28

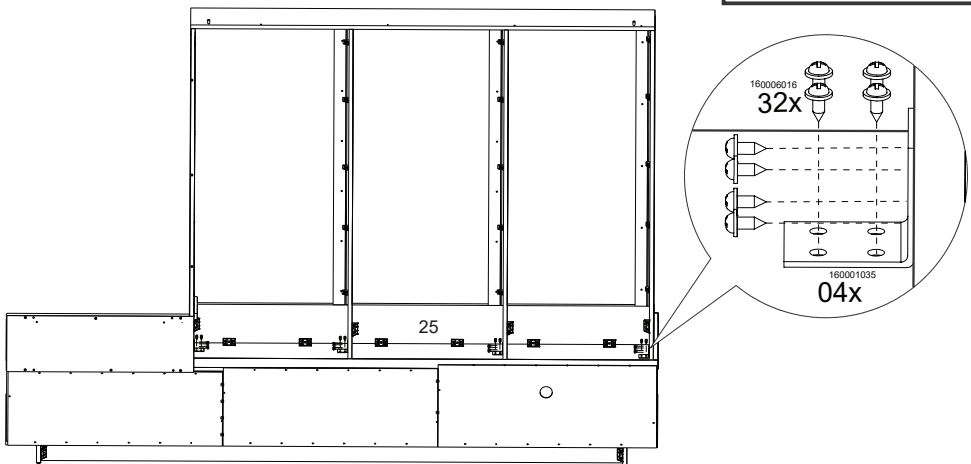
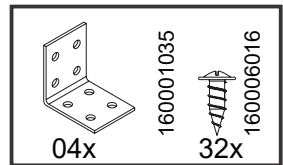

29

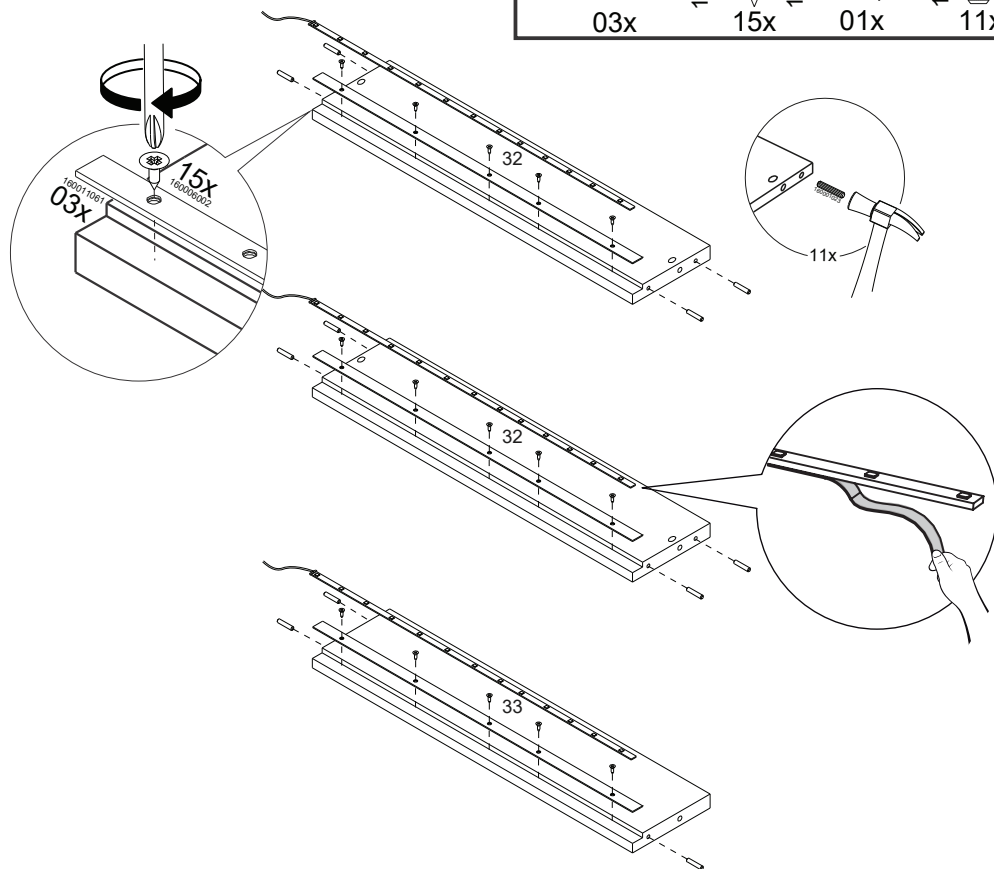
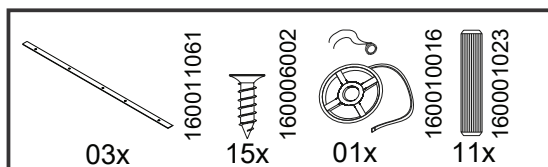

30

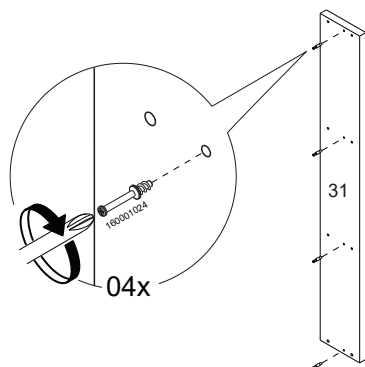
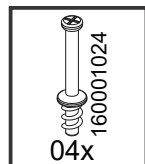

31

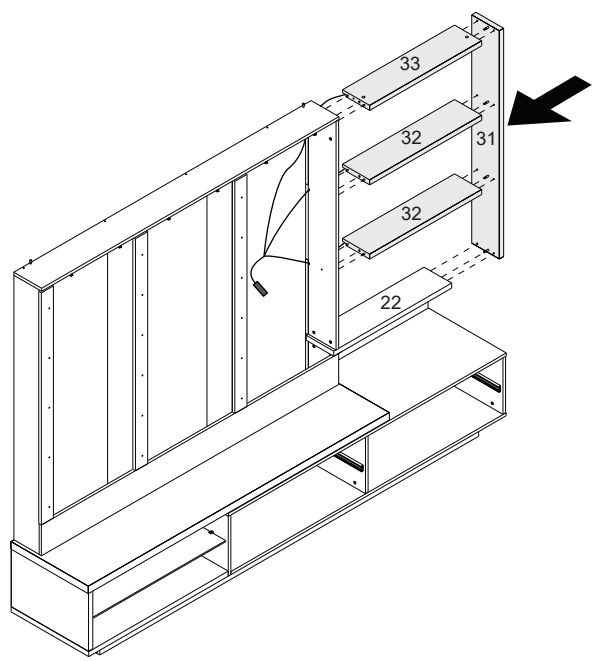

32

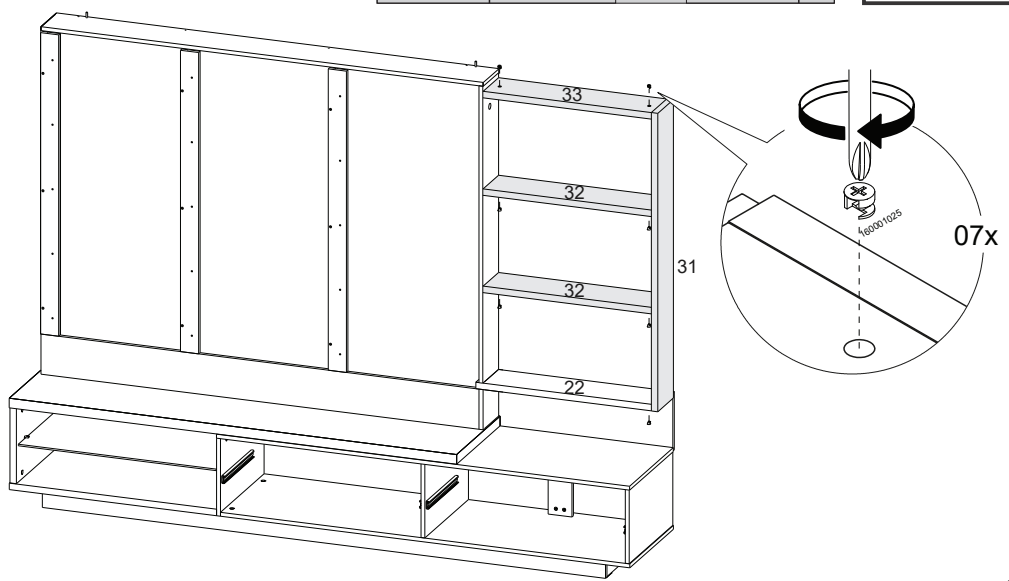
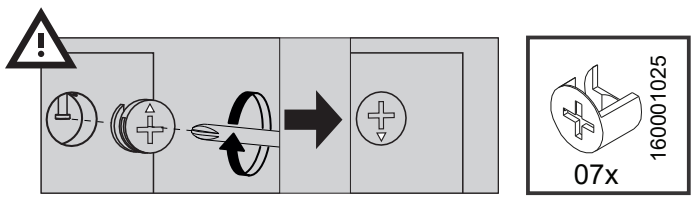

33

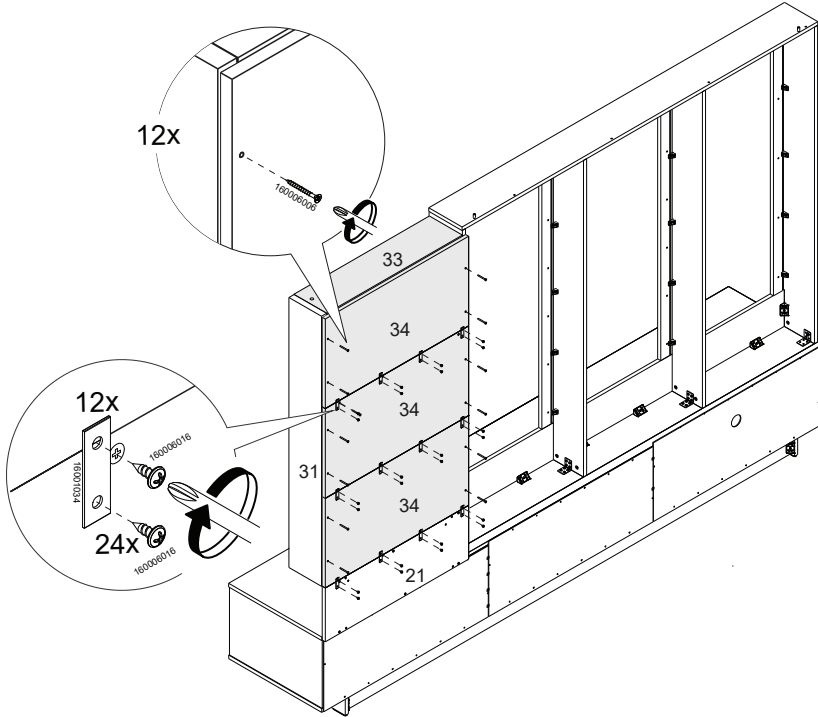
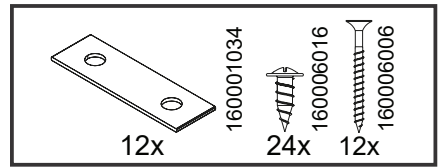

34

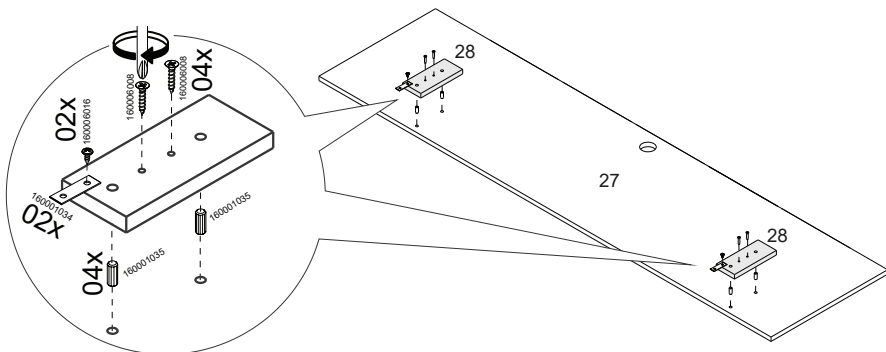
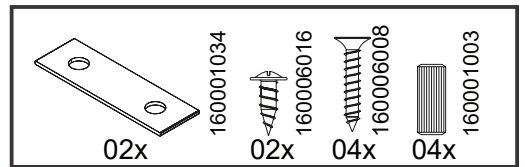

35

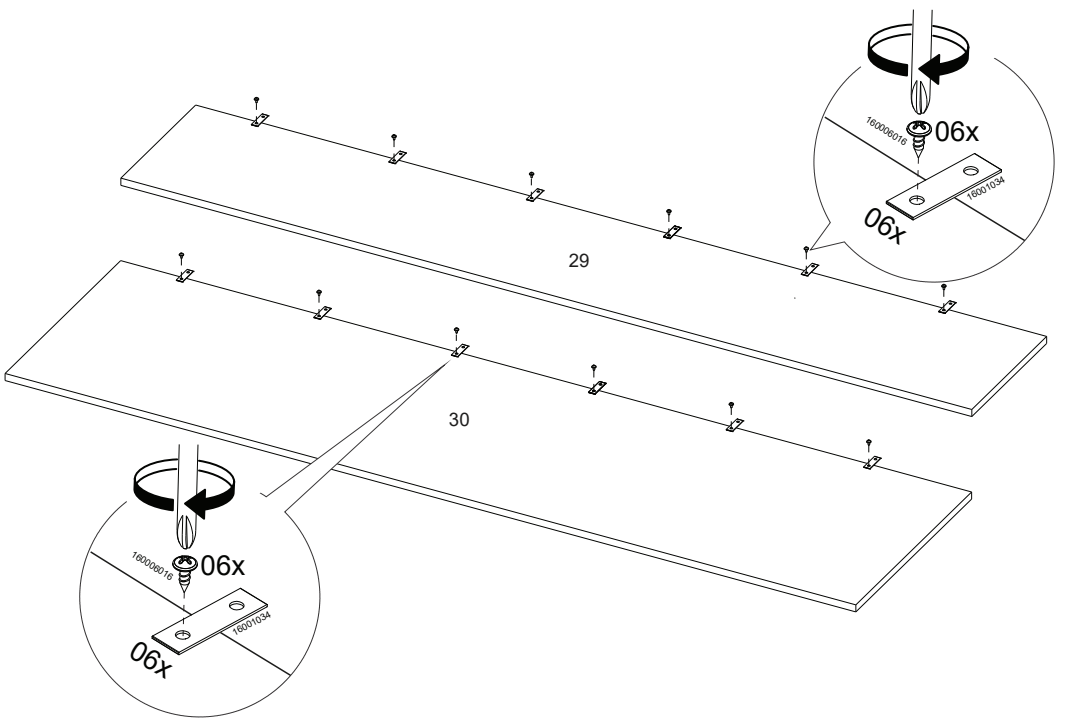
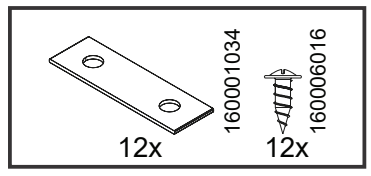

36

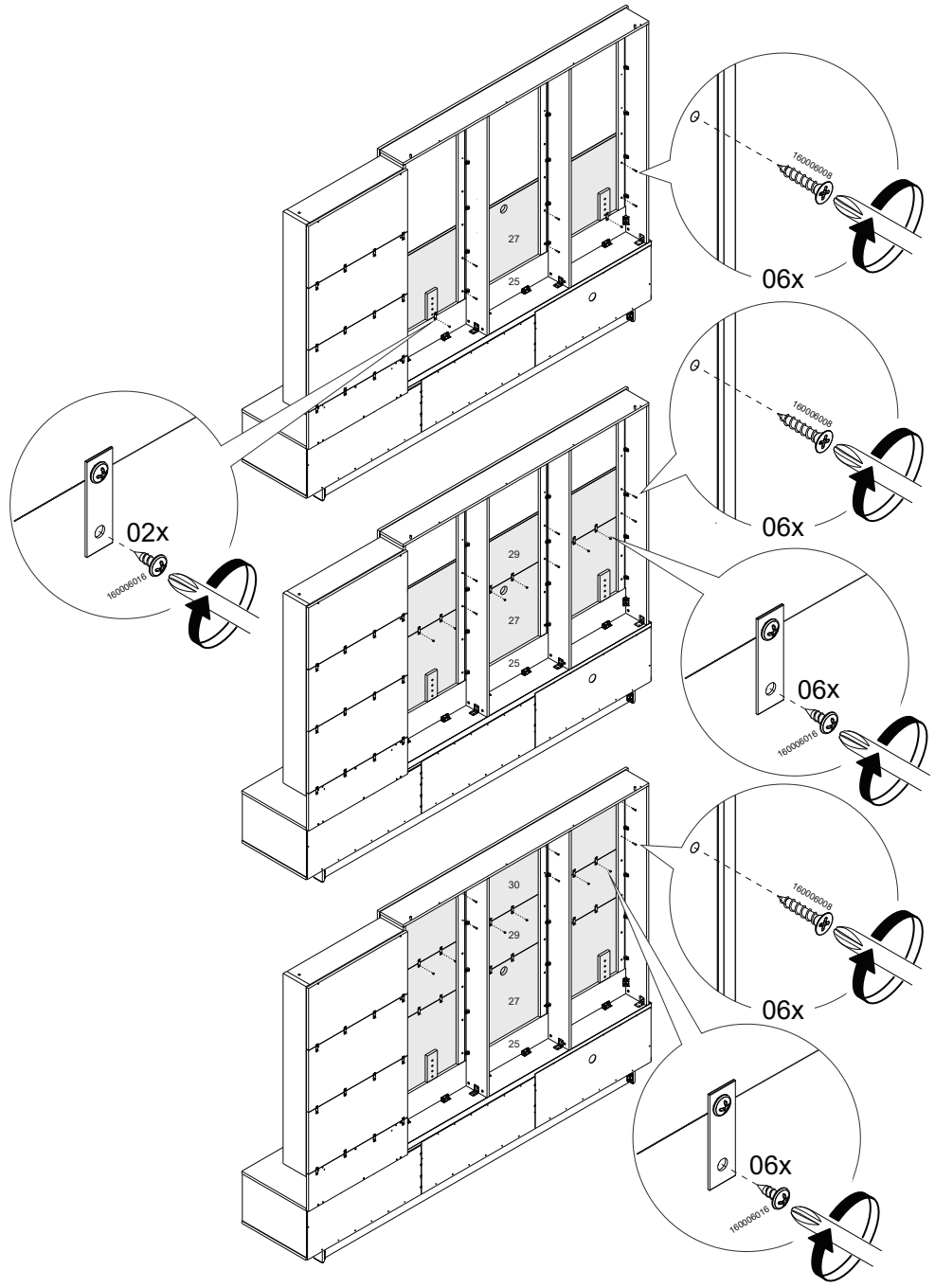
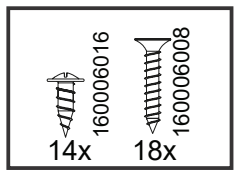

37

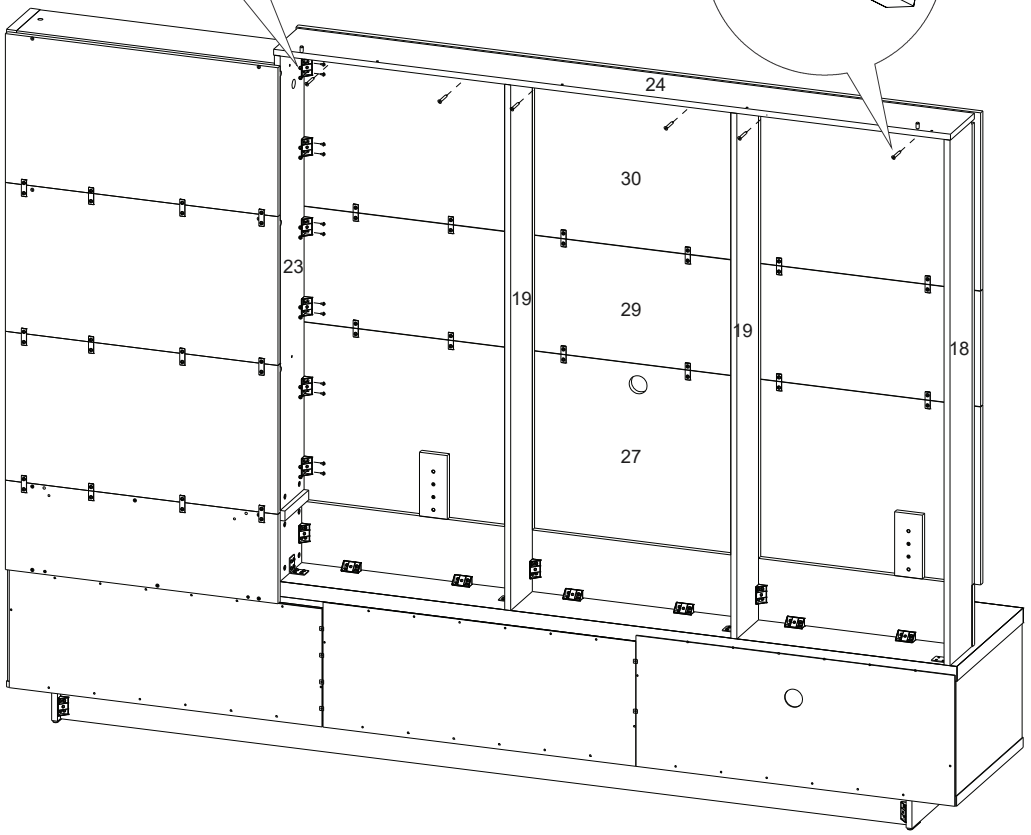
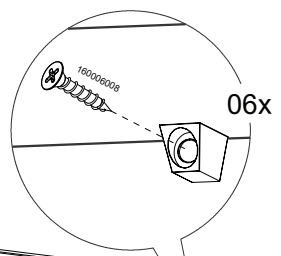
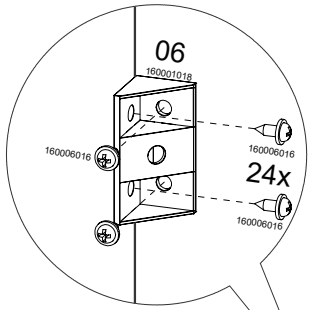
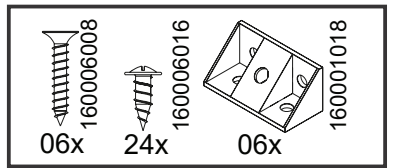

38

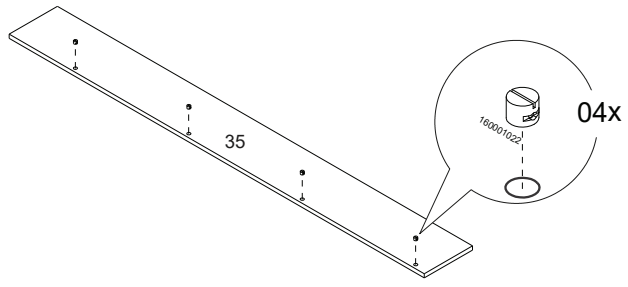
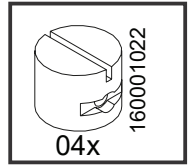

39

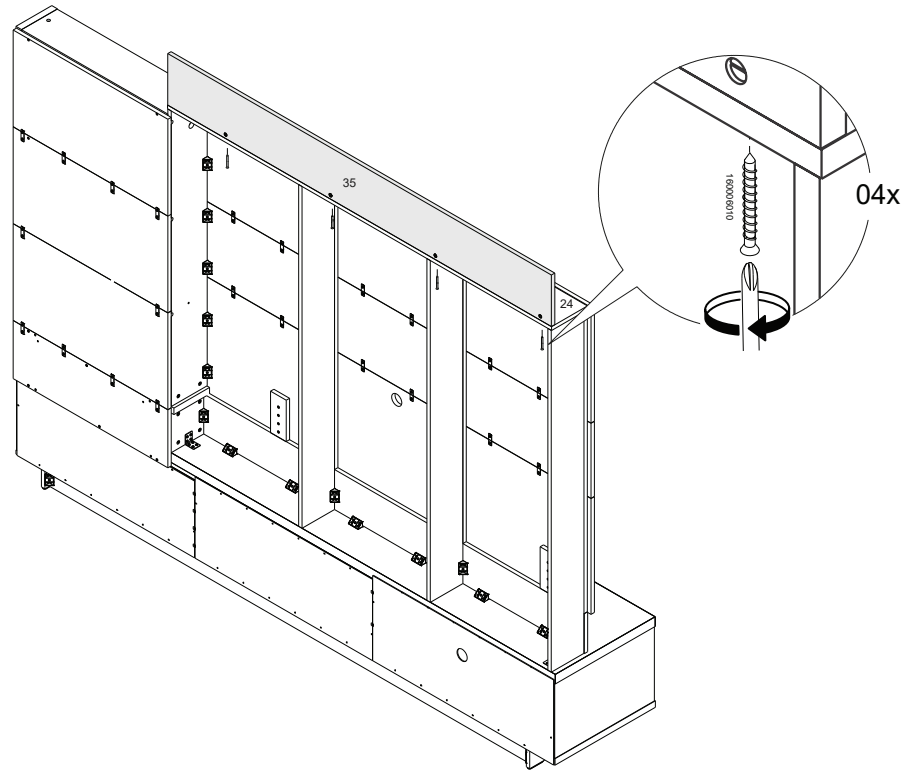
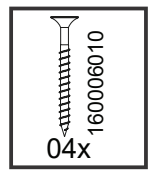

40

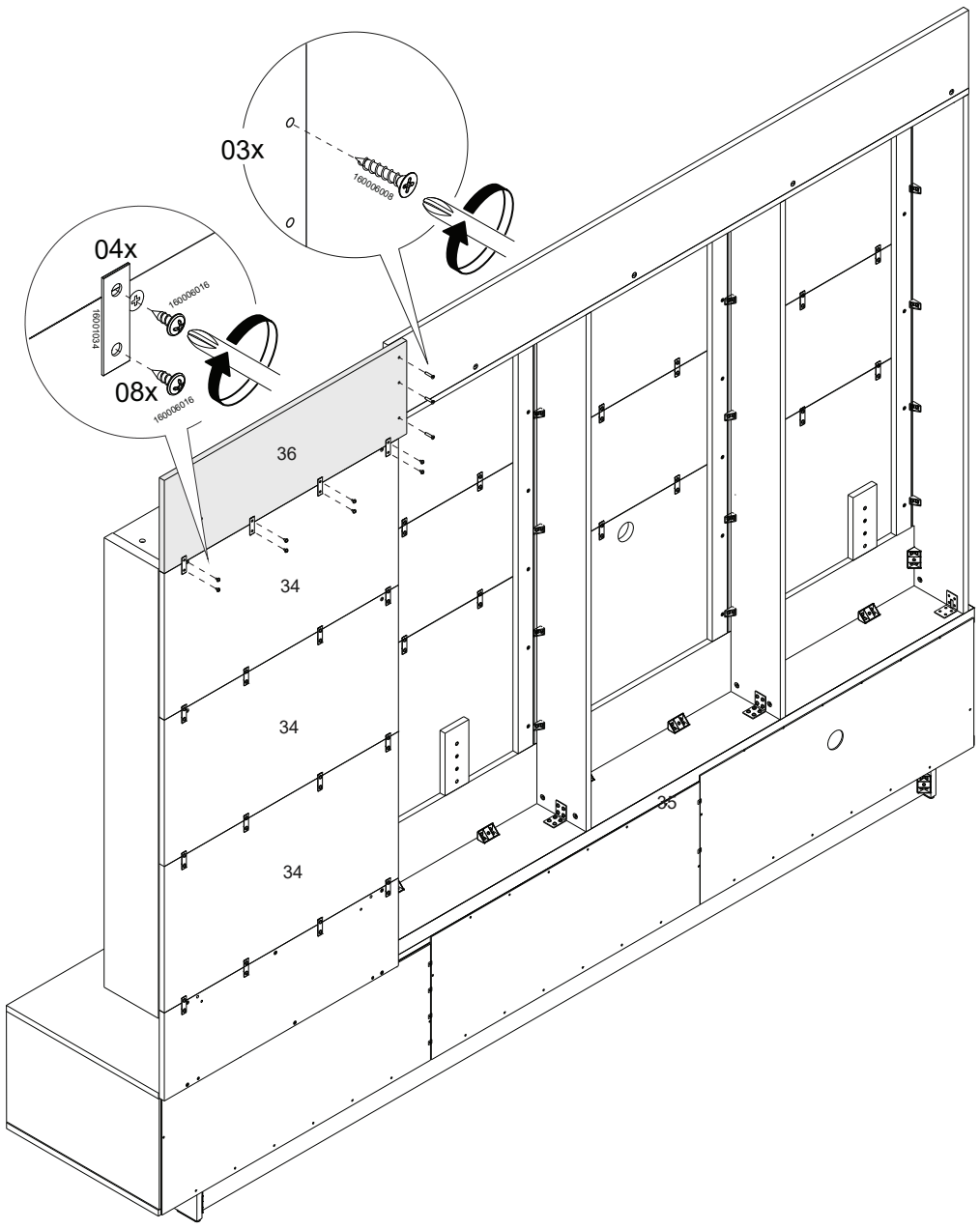
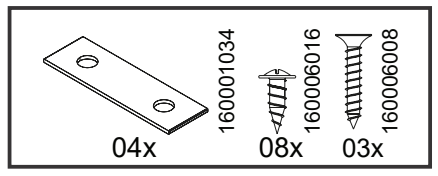

41

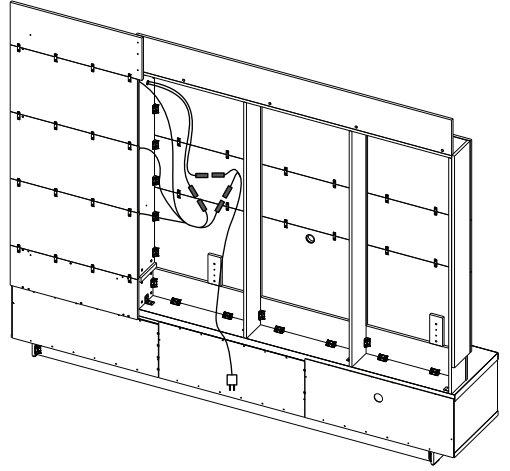
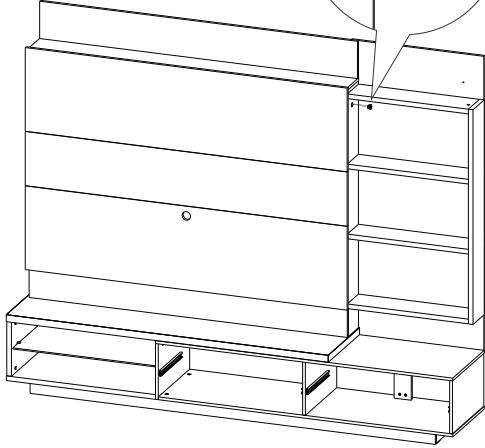
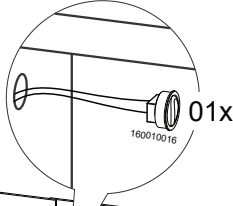
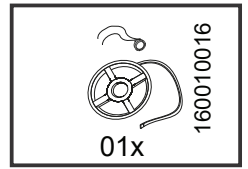

42

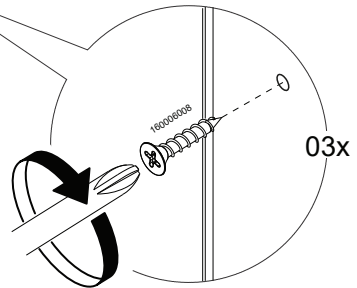
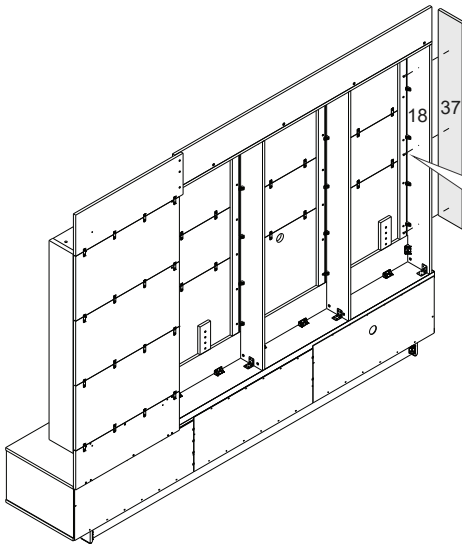
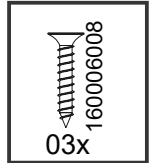

43

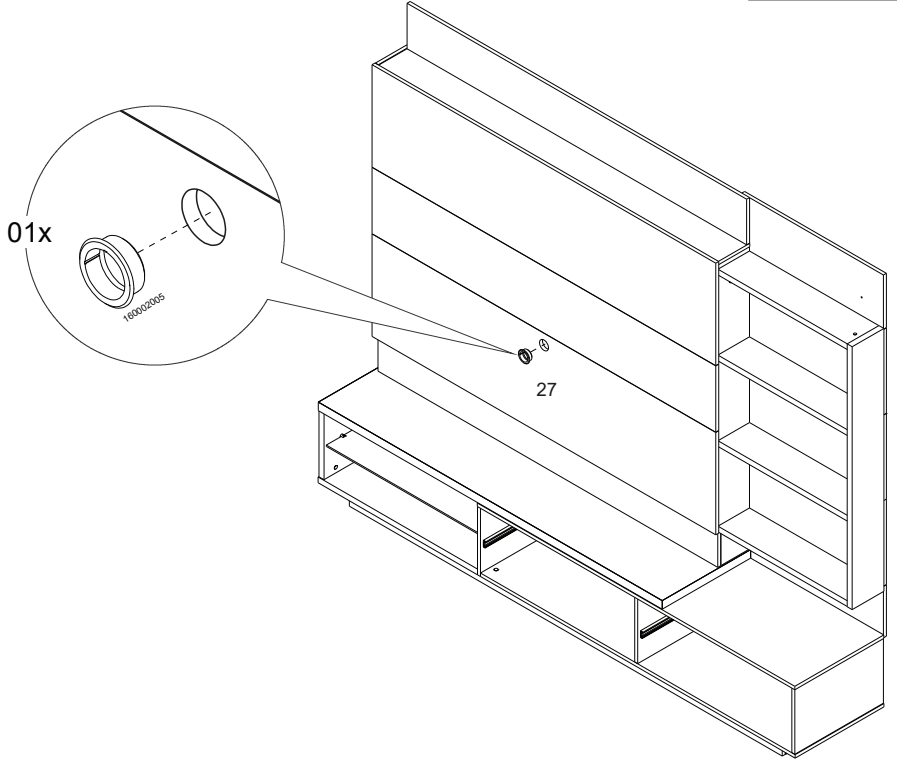
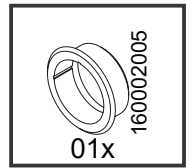

44

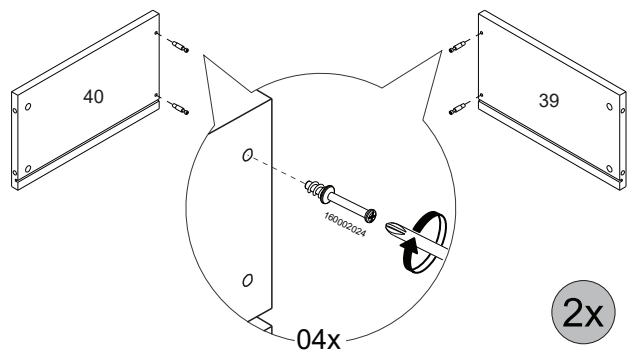
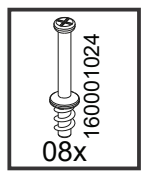

45

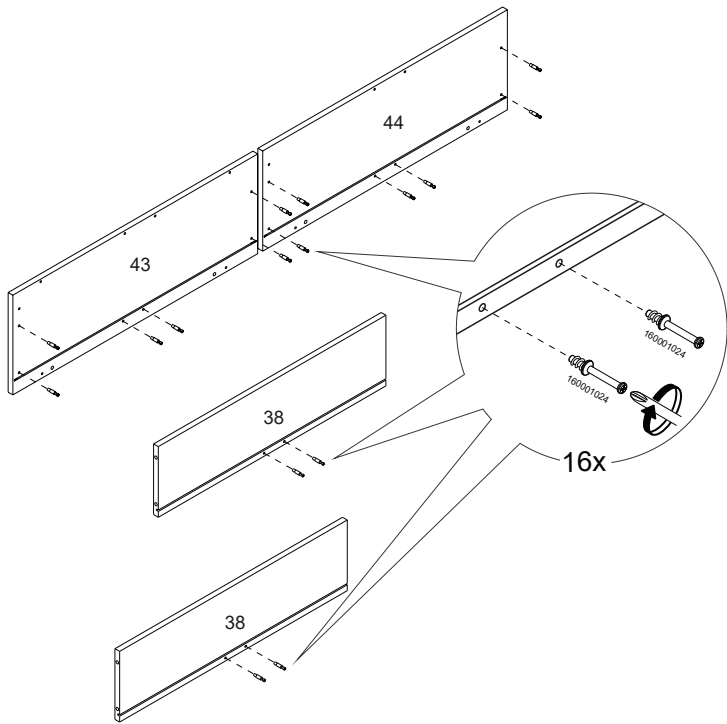
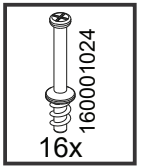

46

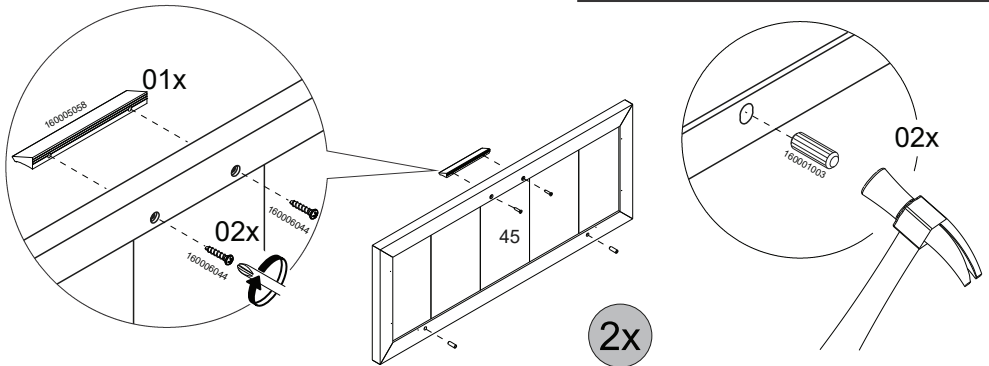
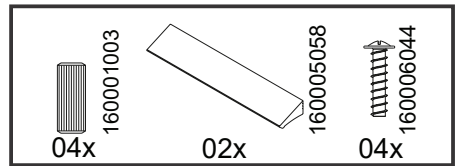

47

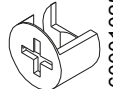
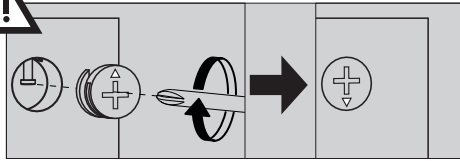

160001025

08x

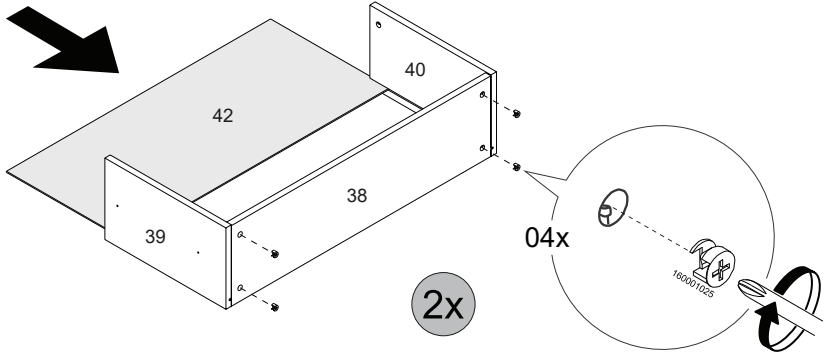

48

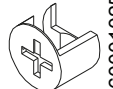
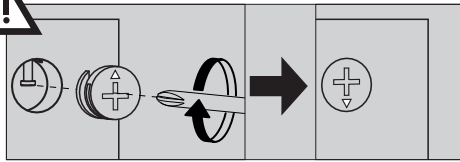

160001025

04x

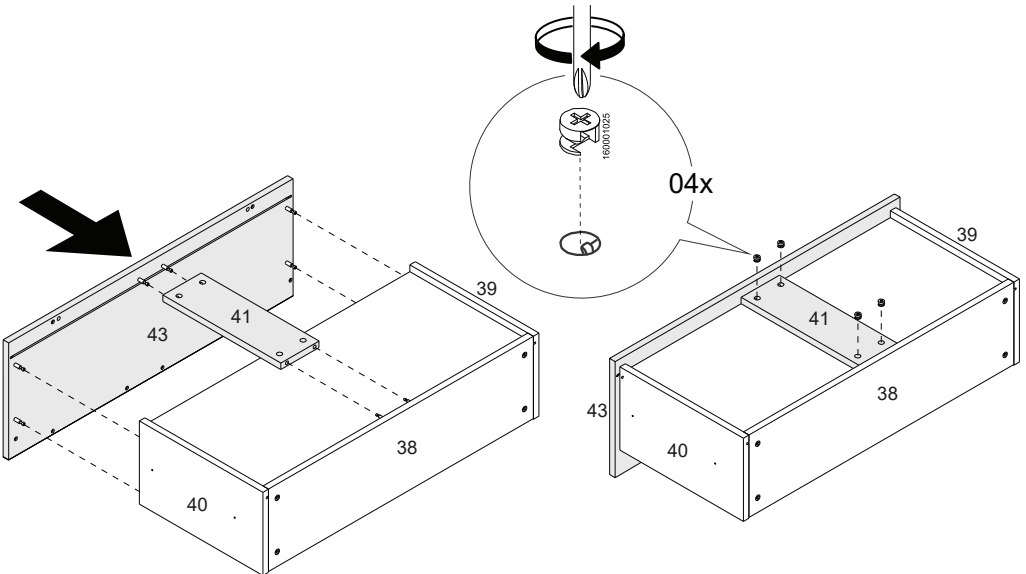

49

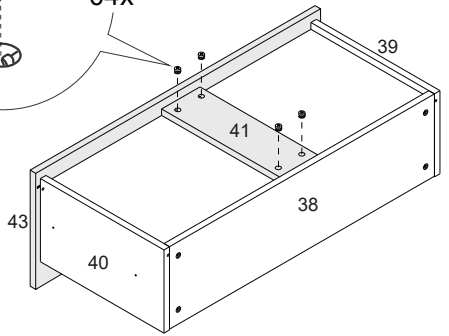
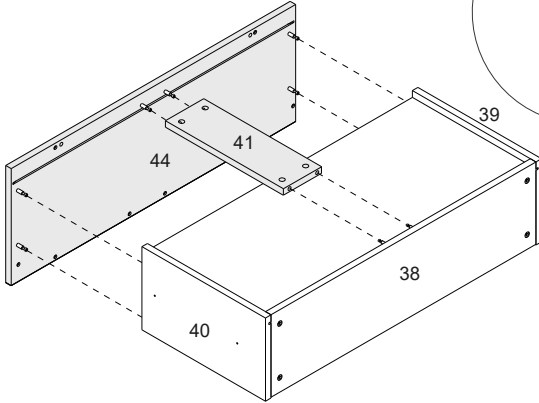
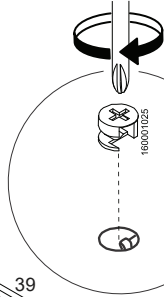
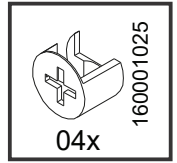
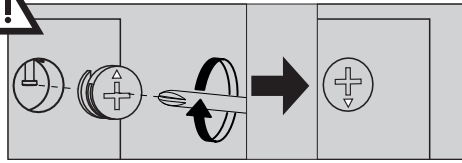

50

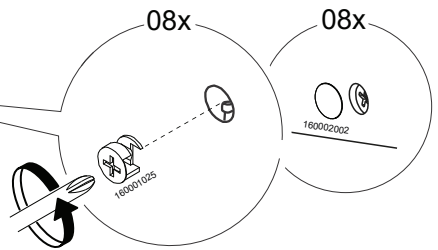
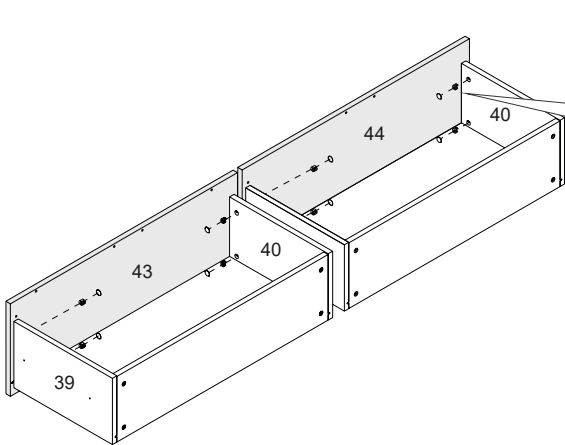
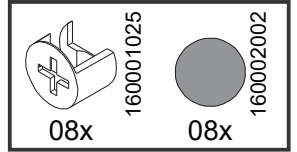
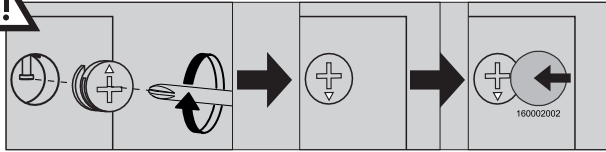

51

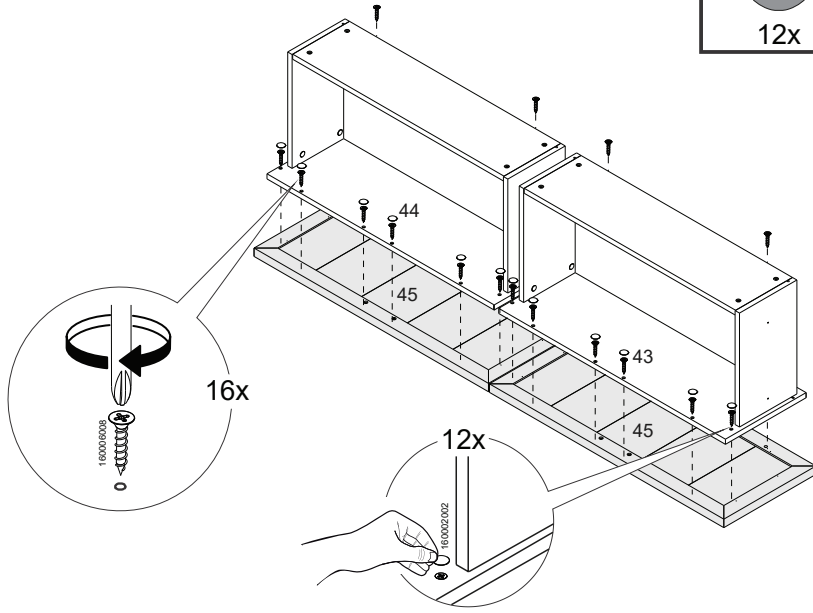
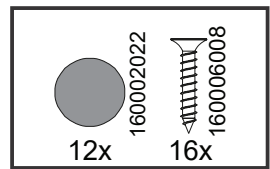

52

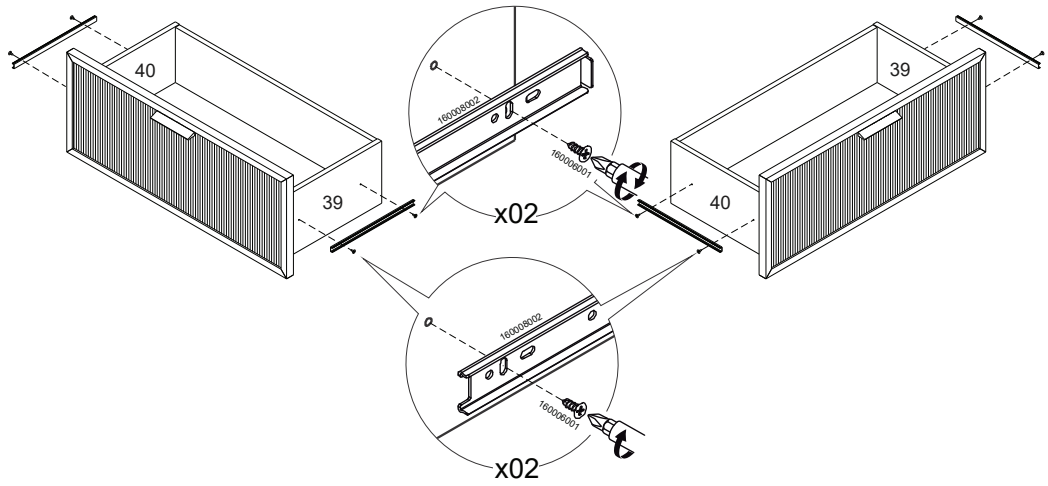
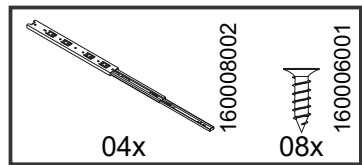

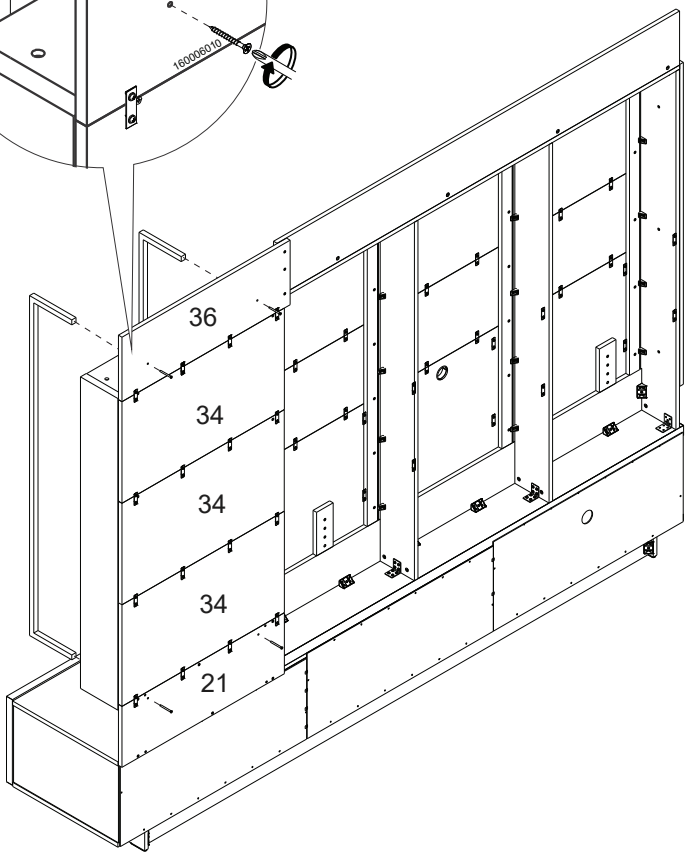
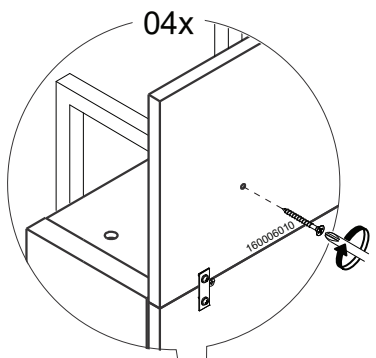
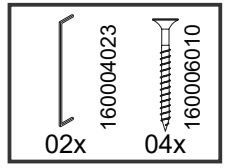

○	160002015
04x	

