

CO9203 - BALCÃO 0,80 M

Manual de Montagem
 Assembly Instructions
 Instrucción de Montaje

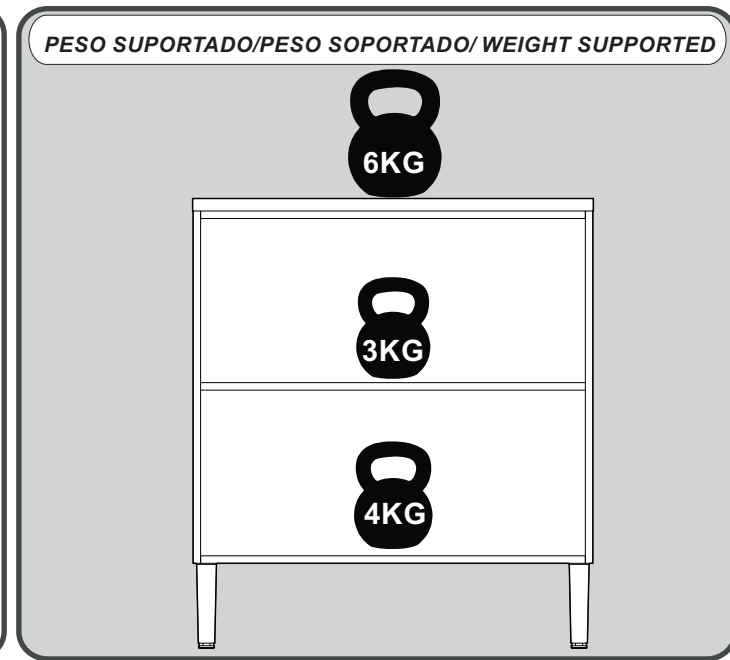
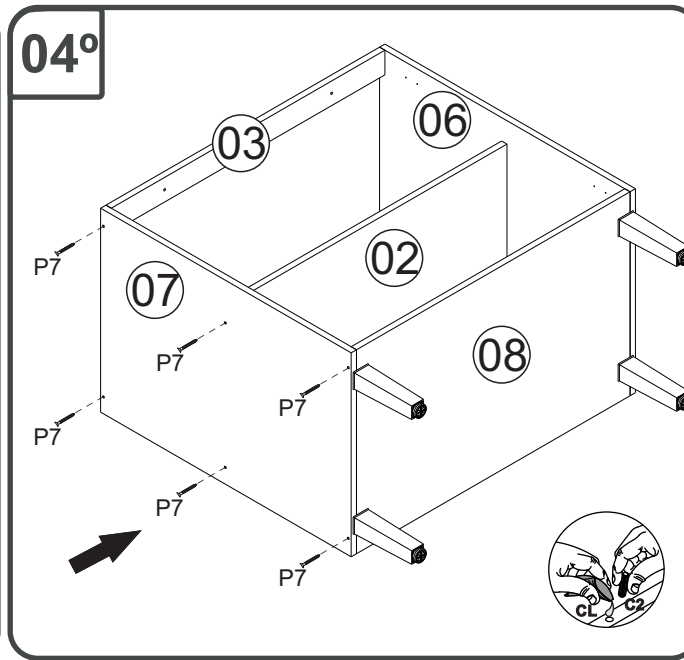
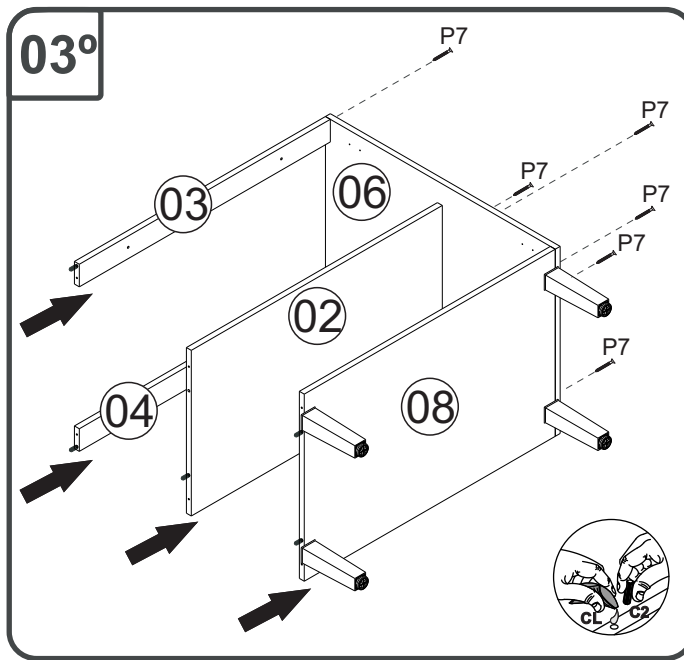
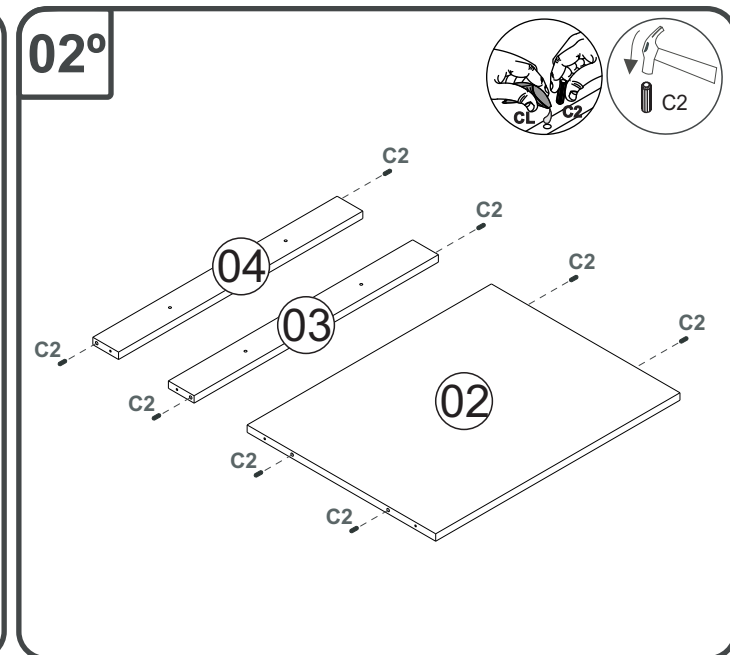
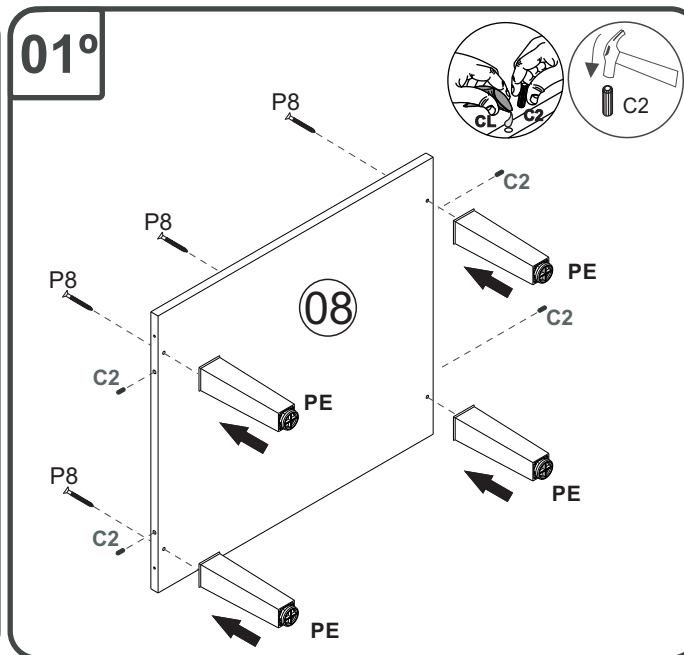
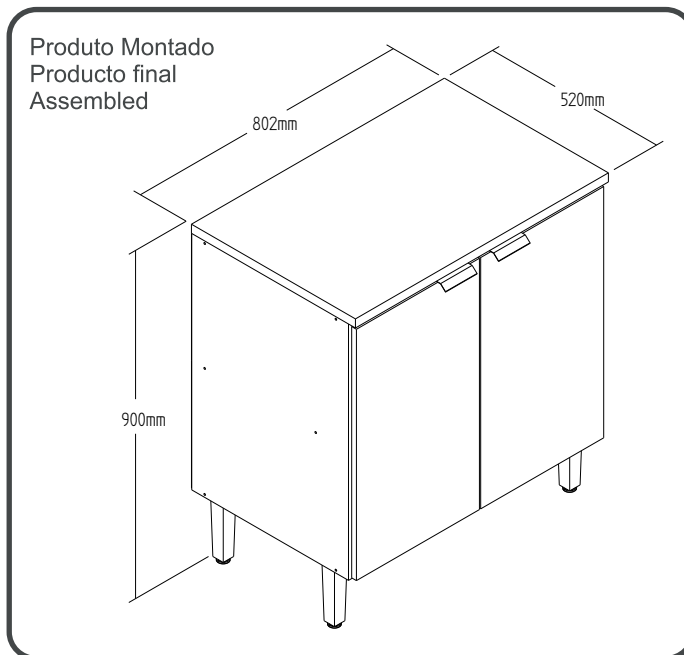

CO9203 - BALCÃO 0,80 M

Manual de Montagem
Assembly Instructions
Instrucción de Montaje

decibal[®]
móveis

07°

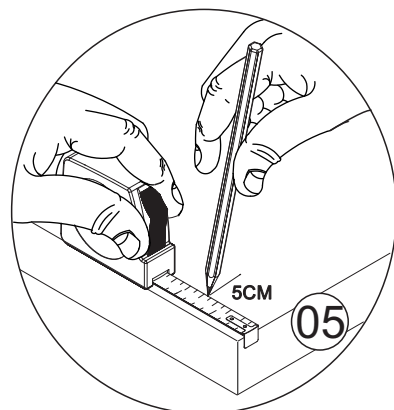
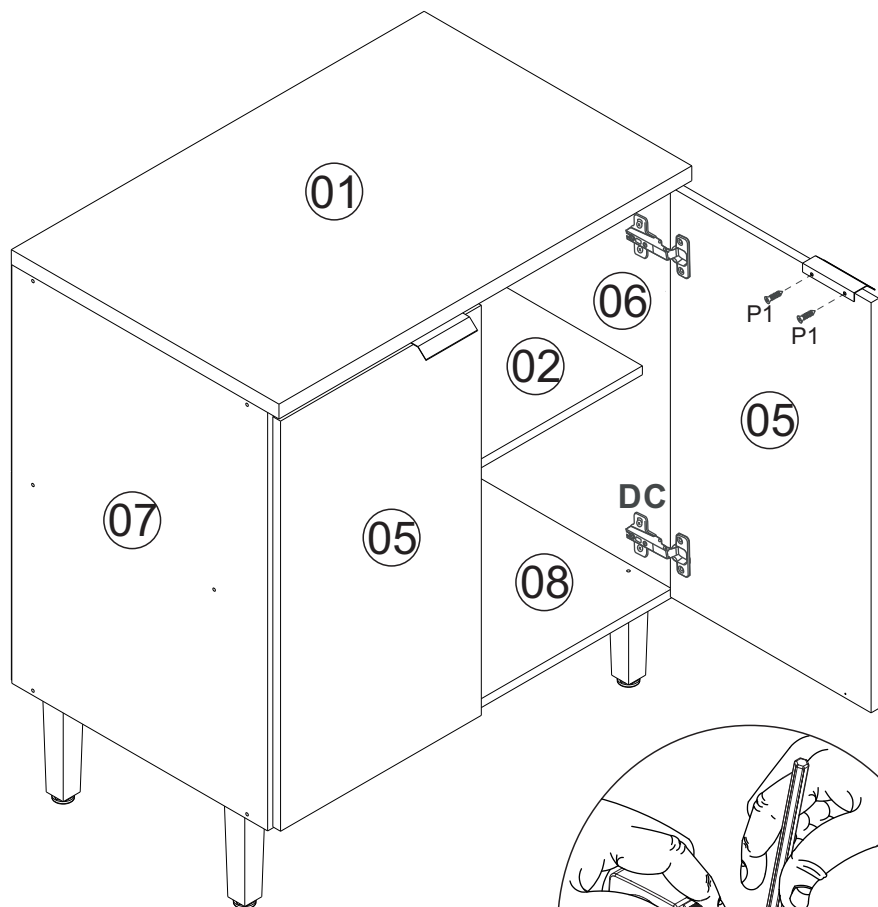
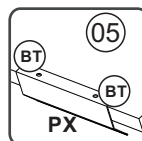
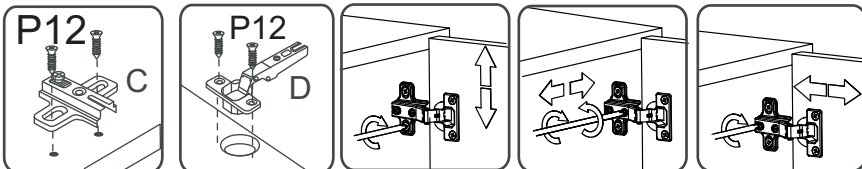

ATENÇÃO!!!!

MARCAÇÃO PRA O PRIMEIRO FURO DO PUXADOR

MARCADO PARA EL PRIMER AGUJERO

MARKING FOR THE FIRST HANDLE HOLE

Relação de Peças/ Relación de Piezas/Parts List

N°	CÓDIGO/CODE	DESCRIÇÃO/DESCRIPCIÓN/DESCRIPTION	QTD/CANT	VOL.
1	0548708	TAMPO/TAPA/TOP	802X520X25MM	1
2	0548712	PRATELERIA/ESTANTE/SHELF	770X440X15MM	1
3	0548714	TRAVESSA FRT/TRAVIESA/TRAVERSE	770X60X15MM	1
4	0548715	TRAVESSA TRS/TRAVIESA/TRAVERSE	770X60X15MM	1
5	0548711	PORTA/PUERTA/DOOR	690X390X15MM	2
6	0548709	LATERAL DIR/LATERAL/SIDE	705X497X15MM	1
7	0548707	LATERAL ESQ/LATERAL/SIDE	705X497X15MM	1
8	0548710	BASE	770X497X15MM	1
9	0548713	COSTA/REVÉS/BACK	796X350X2,8MM	2

www.decibal.com.br

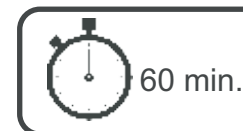

ATENÇÃO!!!! montadores e consumidores
* Ajustar o torque da parafusadeira para não danificar as peças escareando o parafuso *

ATENCIÓN!!!! montadores e consumidores
* Ajuste el torque del destornillador para no dañar las piezas avallando el tornillo *

ATTENTION!!!! assemblers and consumers
* Adjust the torque of the screwdriver so as not to damage the parts by countersinking the screw *

Ferramenta necessárias
Necessary tools
Herramientas necesarias

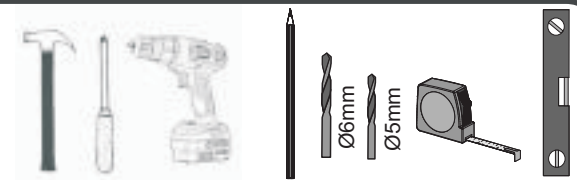

ATENÇÃO!!!! montadores e consumidores
* Para limpar o móveis utilize somente um pano úmido (umedecido em água pura ou água com sabão neutro). Depois, passe um pano seco. Evite a umidade excessiva.
* Evite usar álcool, água sanitária, detergente e outros produtos químicos, mesmo diluídos em água. Não utilize produtos abrasivos de nenhuma espécie

ATENCIÓN!!!! montadores e consumidores
* Para limpiar el mueble utilice solamente un paño húmedo (humedecido con agua limpia o con un jabón suave). A continuación, utilice un paño seco. Evite el exceso de humedad.
* Evite uso de alcohol, hipoclorídoro solución basada, detergente y otros productos químicos, mismo diluídos en agua. No utilice productos abrasivos de ningún tipo.









ATTENTION!!!! assemblers and consumers
* To clean the furniture, use only a damp cloth (humidify it only in pure water ou water and neutral soap). After, use a dry cloth. Avoid excessive humidity.
* Avoid using alcohol, bleach, detergent and other chemical products, even diluted in water. Do not use any kind of abrasive cleaning agents to clean the furniture.
The use of such products may jeopardize the ?nal characteristics of the furniture.

CO9203 - BALCÃO 0,80 M









Manual de Montagem
Assembly Instructions
Instrucción de Montaje



escala (1:1)

LEGENDA	DESCRIÇÃO/DESCRIÇÃO/DESCRIPTION	CÓDIGO	QUANT.
P7	 PARAFUSO/TORNILLO/SCREW 4X45	01318	12
P1	 PARAFUSO/TORNILLO/SCREW 3,5X12	01328	04
Pr1	 PREGO/CLAVO/NAIL 10X10	01330	40
C2	 CAVILHA/TARUGO/DOWEL 6X30 MM	01211	13
PU	 PARAFUSO UNIÃO/UNIÓN DETORNILLO /SCREW UNION	01495	02
P12	 PARAFUSO/TORNILLO/SCREW 3,5X13	09927	24
P8	 PARAFUSO/TORNILLO/SCREW 5X45	01320	04
P5	 PARAFUSO/TORNILLO/SCREW 4X25	01317	04

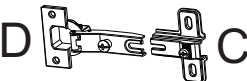
escala (N/A)

LEGENDA	DESCRIÇÃO/DESCRIÇÃO/DESCRIPTION	CÓDIGO	QUANT.
CL	 COLA/PEGAMENTO/GLUE	01213	01
PX	 PUXADOR/PEGADOR /HANDLE (MOV410 /100MM)	11440	02
ET	 ETIQUETA LOGO DECIBAL/LABEL DECIBAL	01312	01
Ct1	 CANTONEIRA/PIEZA L/SHEET	03077	04
FX	 FIXADOR COSTA/FIJADOR FONDO/FIXER COAST	01331	06
PE	 PÉ/PATA/FOOT (170mm) CINZA170mm	11121	04
DC	 DOBRADIÇA/BISAGRA/HINGE D=35mm C=0mm	09449	04
AD	 ADESIVO /ADHESIVO /ADHESIVE	Griseo 11895	12
BT	 BATENTE/BATIENTE DE SILICONA/SILICONE STOP 8MM	02921	04

Medida em mm

