

INSTRUÇÕES DE MONTAGEM

INSTRUCCIONES DE MONTAJE
ASSEMBLY INSTRUCTIONS

Roupeiro Alvorada 03 Portas e 02 Gavetas com Pés / Armario Alvorada 03 puertas y 02 cajones con Pies / Alvorada Wardrobe 03 doors 02 drawers with feet

- BE143-66 Branco/Branco/Rosa-Chá
- BE143-94 Rústico
- BE143-130 Castanho HP

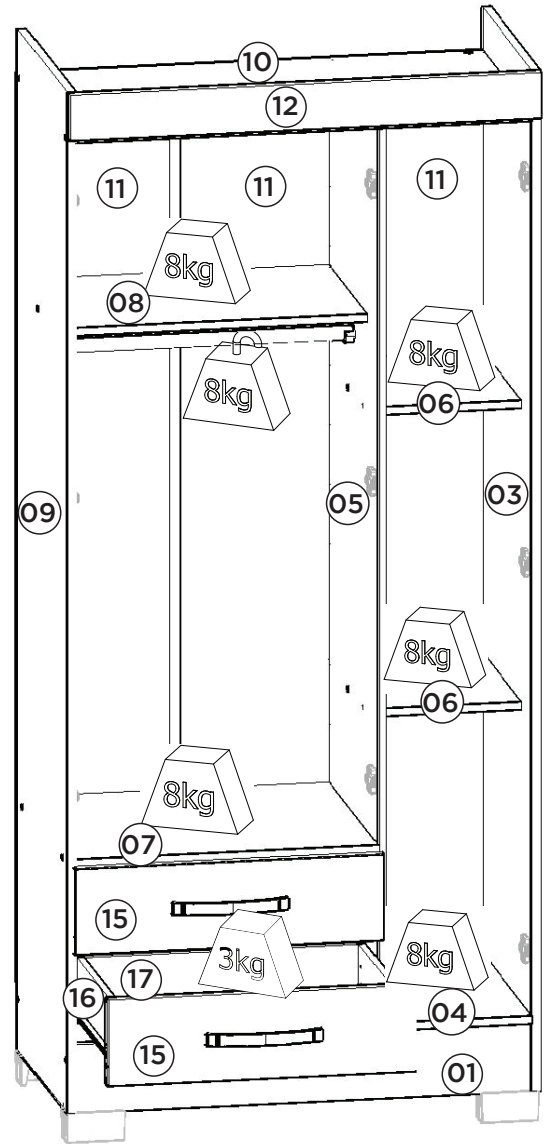
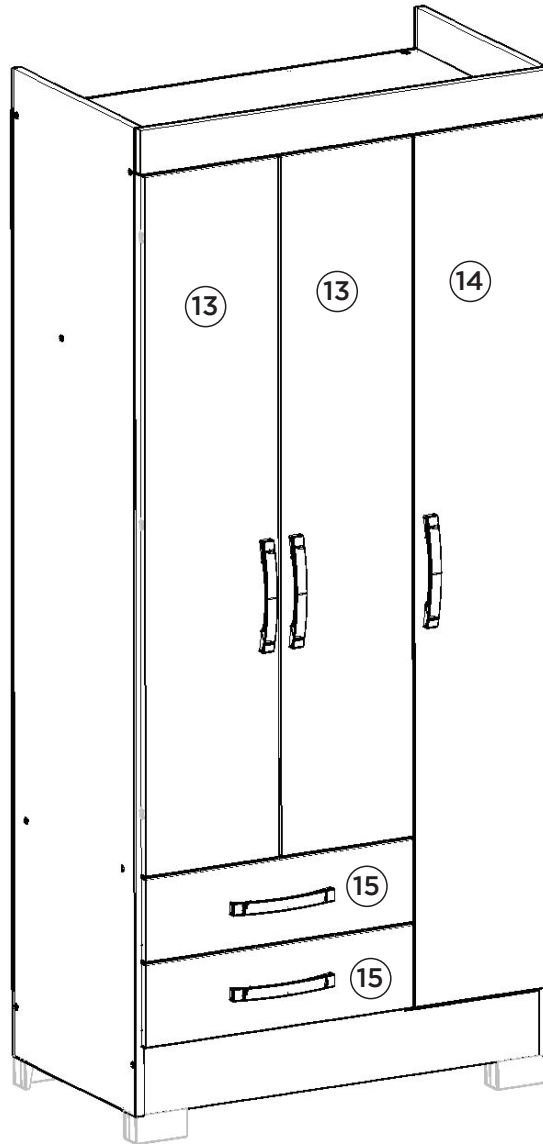

Requisitos para montagem
Requisitor para la montaje
Assembly Requirements

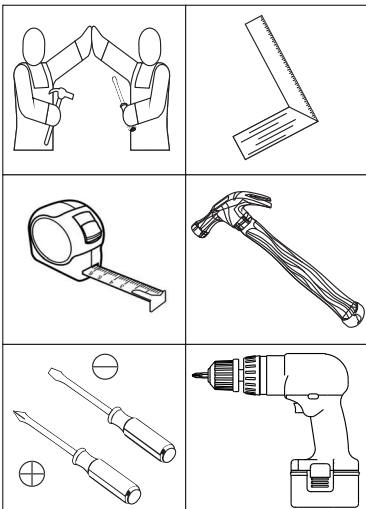

Imagens meramente ilustrativas
Imágenes meramente ilustrativas
Images for illustration only

Pesos máximos recomendados com carga distribuída
Peso máximo recomendado con la carga distribuida
Recommended maximum weights with evenly distributed.

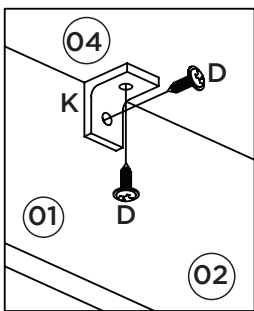
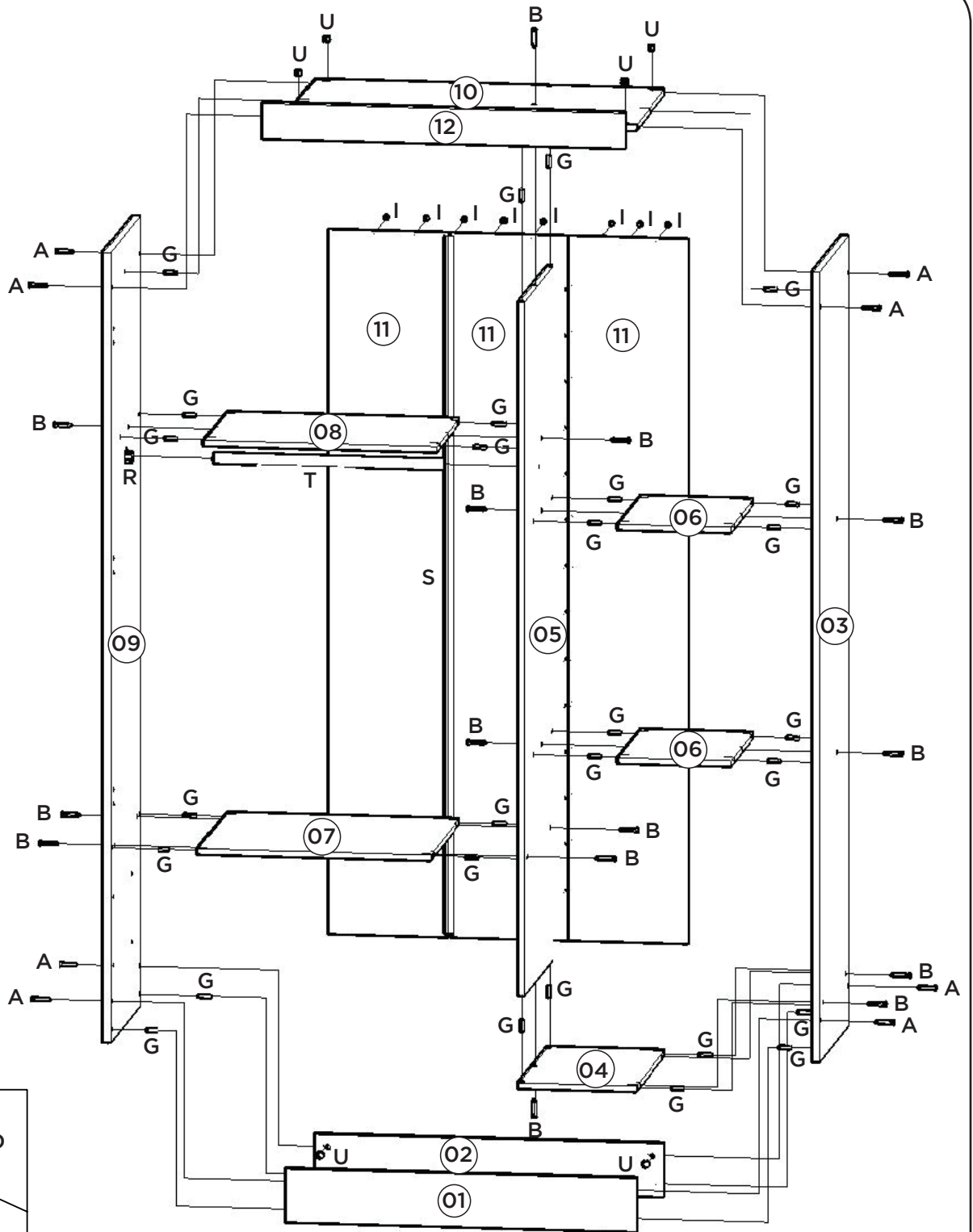
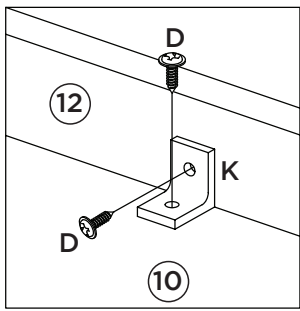

Fixação da cantoneira (K) na base (04) com os rodapés (01) e (02).

Soporte de fijación (K) la base (04) con los pies (01) y (02).

Angle bracket (K) fixing on the base (04) with the footboards (01) and (02).

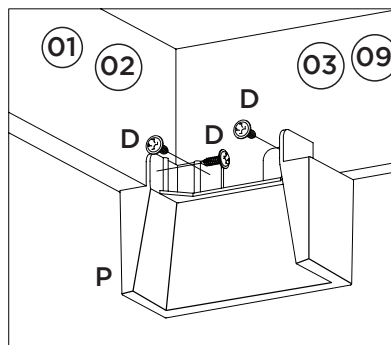

Colocação dos pés "U" (P).

La colocación de los pies "U" (P).

Placement of "U" feet (P).

2°

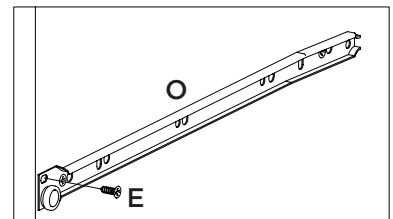
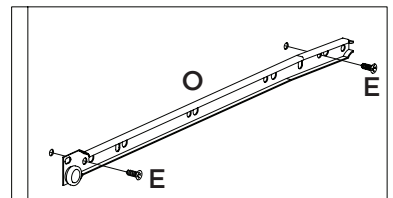
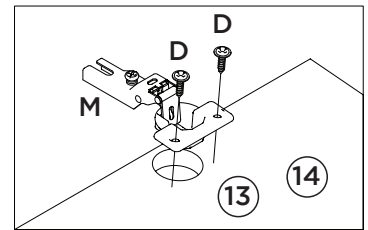
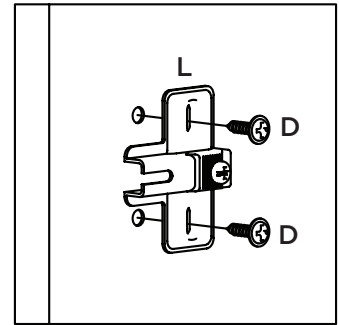
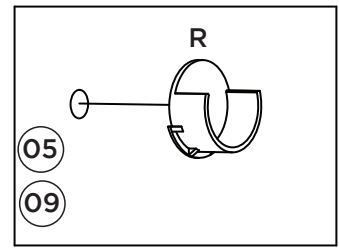
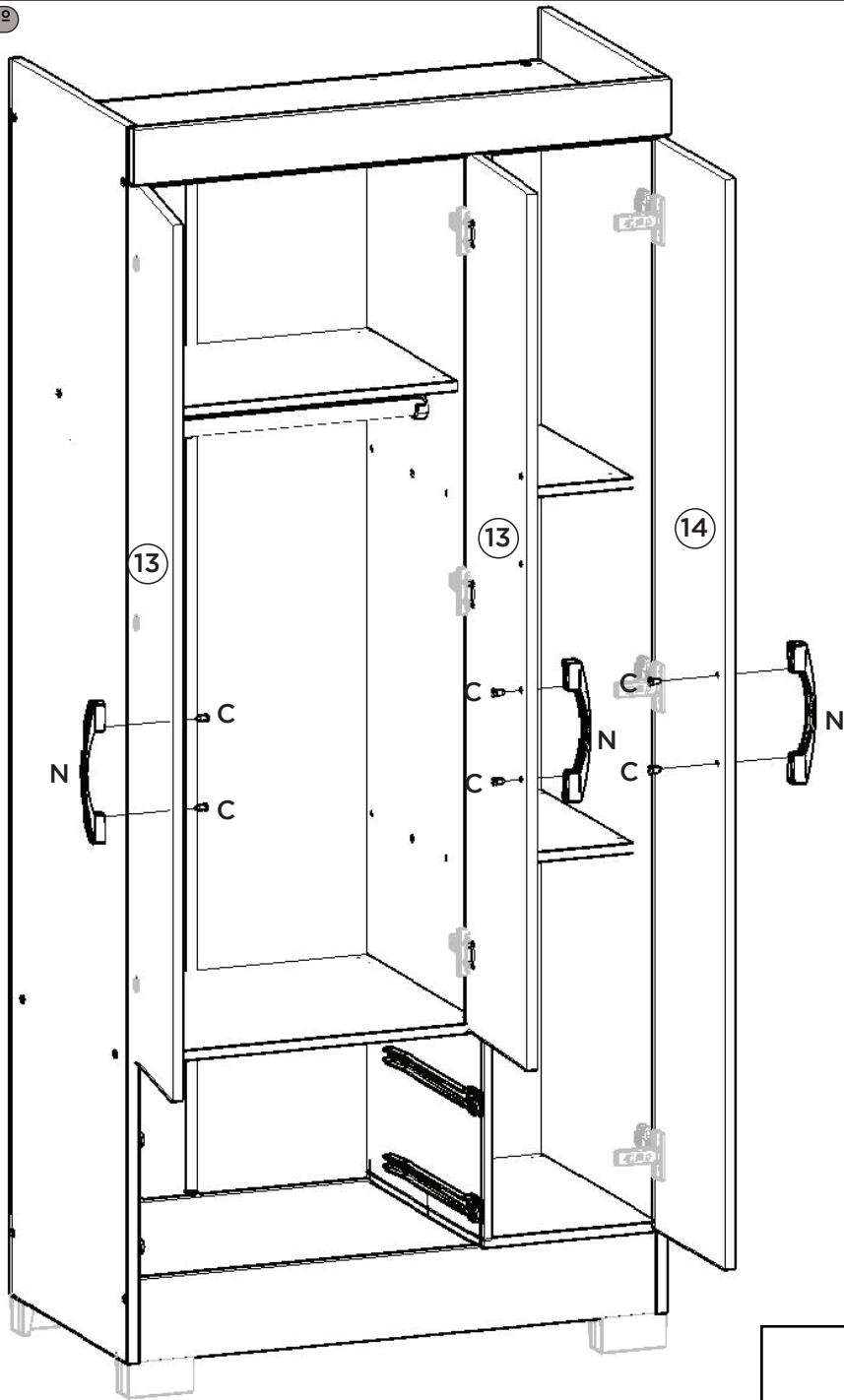

3°

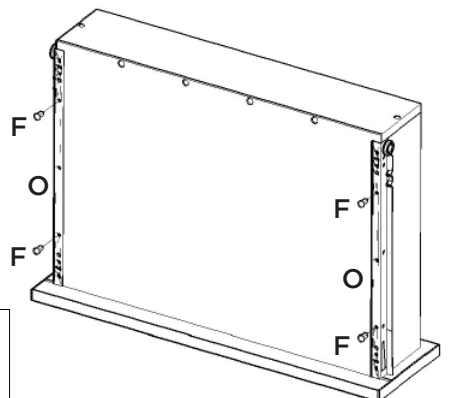
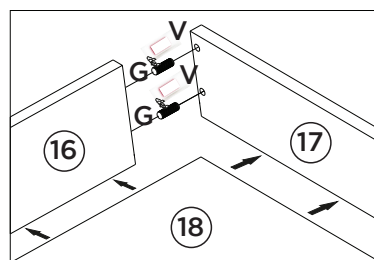
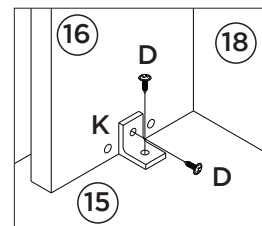
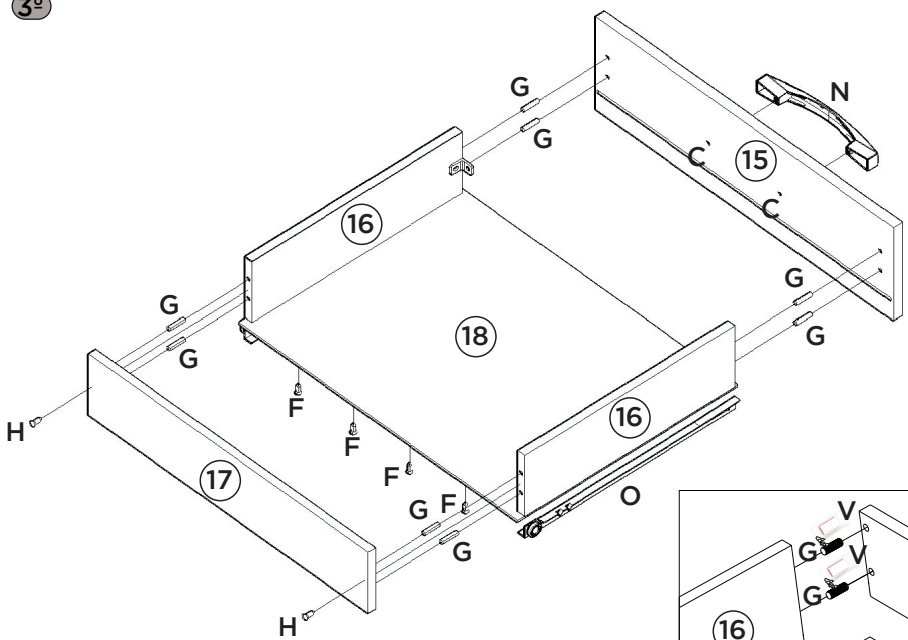

LISTA DE PEÇAS | LISTA DE PIEZAS | LIST OF PARTS

Item	Caixa Caja Box	Qtd Ctd Qty	Descrição Descripción Description	Medidas (mm) Dimensions (mm) Size (measurements) (mm)
01	1/1	01	Rodapé frontal Pie frontal Front footboard	792x120x12
02	1/1	01	Rodapé traseiro Pie trasero Rear footboard	792x120x12
03	1/1	01	Lateral direita Lateral derecho Right side	1800x445x12
04	1/1	01	Base Base Base	267x445x12
05	1/1	01	Divisão División Division	1580x445x12
06	1/1	02	Prateleira menor Estante menos Smaller tray	255x350x12
07	1/1	01	Tampa das gavetas Cubre cajones Drawer cover	525x445x12
08	1/1	01	Prateleira Estante Shelf	525x350x12
09	1/1	01	Lateral esquerda Lateral izquierdo Left side	1800x445x12
10	1/1	01	Tampo superior Panel superior Top cover	792x455x12
11	1/1	03	Fundo Fondo Bottom	1604x268x3
12	1/1	01	Chapéu Sombrero Hat	814x80x15
13	1/1	02	Porta menor puerta más pequeña Smaller door	1276x265x15
14	1/1	01	Porta Puerta Door	1588x265x15
15	1/1	02	Frente de gaveta Frente de cajón Drawer front	533x152x15
16	1/1	04	Lado de gaveta Lado del cajón Drawer side	350x100x12
17	1/1	02	Ripa de trás Malla detrás Rear batten	500x100x12
18	1/1	02	Fundo de gaveta Fondo del cajón Drawer bottom	499x367x3

FERRAGENS | HERRAJES | HARDWARE

A  Parafuso 4,5x50mm CHT. Tornillo 4,5x50mm CHT. Screw 4,5x50mm CHT.	B  Parafuso 3,5x40mm CHT. Tornillo 3,5x40mm CHT. Screw 3,5x40mm CHT.	C  Parafuso 3,5x25mm FLA. Tornillo 3,5x25mm FLA. Screw 3,5x25mm FLA.	D  Parafuso 3,5x12mm FLA. Tornillo 3,5x12mm FLA. Screw 3,5x12mm FLA.	E  Parafuso 3,5x12mm CHT. Tornillo 3,5x12mm CHT. Screw 3,5x12mm CHT.	F  Parafuso 3,0x16mm CHT. Tornillo 3,0x16mm CHT. Screw 3,0x16mm CHT.	G  Cavilha 5x25mm Cinta 5x25mm Dowel 5x25mm	H  Prego 12x12mm Anelado Clavo 12x12mm Anillado Ringed Nails 12x12mm
I  Prego 10x10mm Clavo 10x10mm Nail 10x10mm	J  Fixador de fundos Fijador de fondos Bottom fixer	K  Cantoneira plástica Cantонера plástica Plastic angle brackets	L  Calço metal 5mm Calzado metálico 5mm 5mm metal shim	M  Dobradiça metal 26mm Bisagra de metal 26mm 26mm metal hinge	N  Puxador Indonésia 128mm Tirador Indonésia 128mm 128mm Indonésia Handle	O  Corrediça metal 350mm Corredera de metal 350mm Sliding metal 350mm	P  Pé "U" 50x40x100mm Pie "U" 50x40x100mm 50x40x100mm "U" feet
Q  Etiqueta resinada Briz Etiqueta resinada Briz Briz resin label	R  Suporte cabideiro Soporte de percha Coat hanger support	S  Perfil "I" 1589mm Perfil "I" 1589mm Profile "I" 1589mm	T  Cabideiro Madeira 519mm Cabezal Madera 519mm 519mm wooden hanger	U  Porca cilíndrica Tuerca cilíndrica Cylindrical nut	V  Sachê de cola Bolsa de pegamento Glue bag	W  Adesivo tapa parafuso 10mm Adhesivo tapón de tornillo 10mm Bolt cover adhesive 10mm	

AVISO

Para limpeza de seu móvel, use uma flanela seca ou umedecida, e não utilize produtos químicos que possam danificar seu produto.

SISTEMA DE MONTAGEM

O sistema de montagem dos produtos, funciona de acordo com a ordem crescente dos números indicados no desenho. Ex: 01, 02, 03, 04... até a conclusão da montagem.

ADVERTENCIA

Para limpieza de su móvil, use una flanela seca o húmeda, y no utilice productos químicos que puedan dañar su producto.

SISTEMA DE MONTAJE

El sistema de montaje de los productos funciona de acuerdo con el orden creciente de los números indicados en el dibujo. Ej.: 01, 02, 03, 04... hasta la conclusión del montaje.

NOTICE

To clean your furniture, use a dry or wet cloth, and do not use chemicals that may damage your product.

ASSEMBLY SYSTEM

The products' assembly system works according to the increasing order of the indicated numbers. For example: 01, 02, 03, 04 ... to the end of the assembly.