

F33

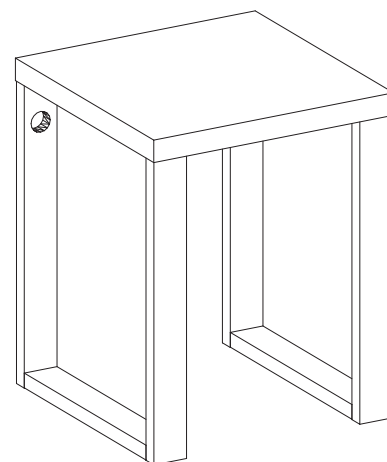
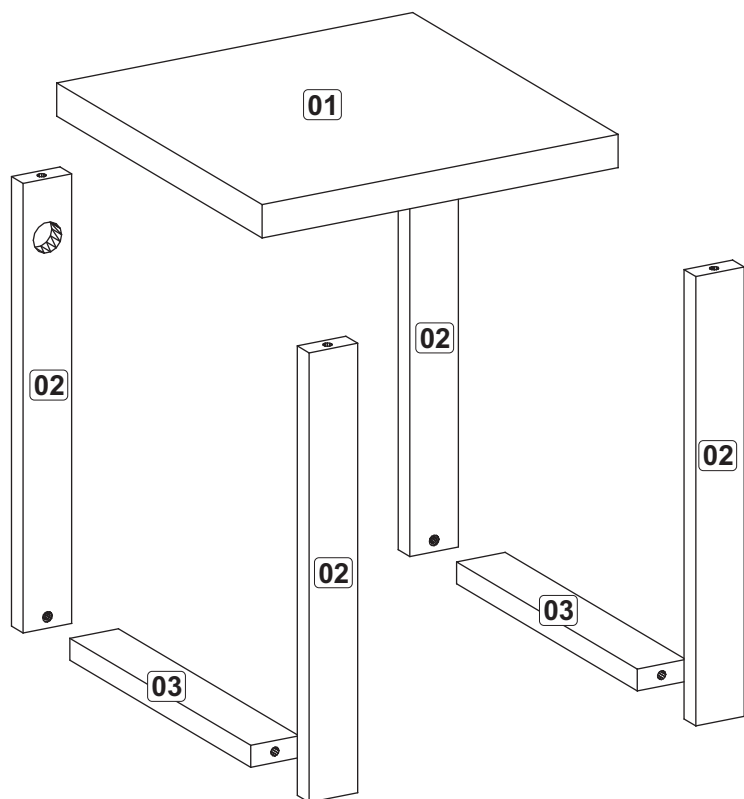

Caixa	Nº	Relação de Peça	Qtde	Medida Peça Corte	Medida Peça Pronta	Sup.	Borda
A	1	Tampo	1	444 x 444 x 38	440 x 440 x 38	A/C	A/A A/A
		Painel A	1	444 x 444 x 6	444 x 444 x 6	A/D	D/D D/D
		Painel B	1	444 x 444 x 6	444 x 444 x 6	C/D	D/D D/D
		Engr 444	2	444 x 40 x 25	444 x 40 x 25	D/D	D/D D/D
		Engr 364	2	364 x 40 x 25	364 x 40 x 25	D/D	D/D D/D
4A	2	Pé	4	512 x 59 x 25	512 x 58 x 25	A/A	A/A D/D
2A	3	Travessa pé (F13)	2	-	-	-	-