



**MANUAL DE MONTAGEM  
ASSEMBLY INSTRUCTIONS  
INSTRUCCIONES DE MONTAJE**

**COD BR: BC 85**



# Sumário Summary Resumen

Introdução Introduction Introducción	.....	3
Antes de começar Before starting Antes de comenzar	.....	4
Evite acidentes Avoid accidents Evitar accidentes	.....	4
Dimensões e ferramentas Dimensions and tools Dimensiones y herramientas	.....	5
Identificação das peças Identifying parts Identificación de las piezas	.....	6
Acessórios incluídos na caixa Hardware included in box Accesorios incluidos en la caja	.....	7
Montagem do móvel Furniture assembly Montaje del mueble	.....	8

## Introdução Introduction Introducción

Leia atentamente este manual e siga os passos indicados para que o produto não perca a garantia e também para uma perfeita montagem.

Read this manual and follow the steps in order to keep the guarantee and also for the perfect fit.

Lea este manual y siga los pasos para que el producto no pierda la garantía y también para el ajuste perfecto.

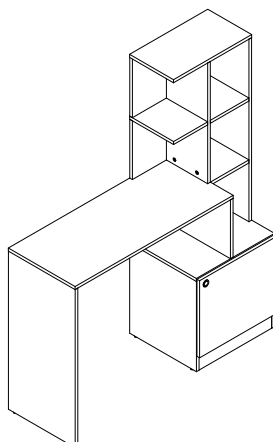

## Antes de começar Before starting Antes de comenzar

Antes de começar a montagem prepare o ambiente, deixando-o completamente limpo e com bom espaço para iniciar o trabalho.

Prepare the room before starting the assembly, leaving it completely clean and the area in good condition to start the work.

Antes de comenzar el montaje preparar el ambiente, dejándolo completamente limpio y con bueno espacio para comenzar el trabajo.

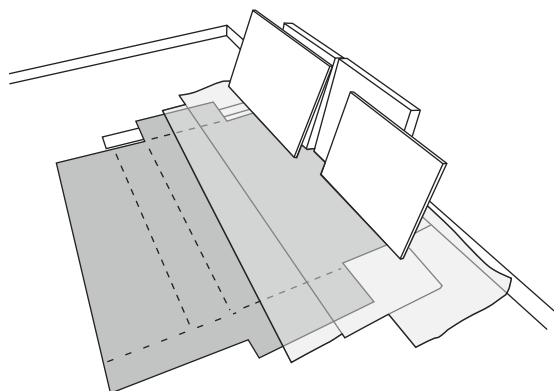

Utilize o papelão da própria embalagem para separar e apoiar as peças retiradas das caixas.

Use the cardboard of the packaging to separate and support the parts removed from the boxes.

Utilice el cartón de la embalaje para separar y apoyar las piezas desmontadas de las cajas.

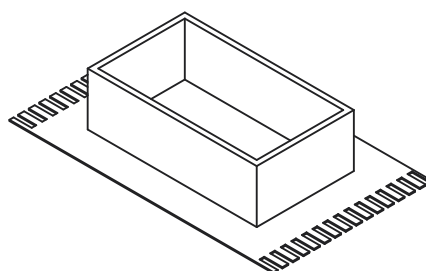

Forre a área de montagem com um cobertor ou tapete. Assim, você evita avarias nas peças durante o processo de montagem.

Cover the assembly area with a blanket or carpet to avoid damaging the parts during the assembly process.

Cubrir la zona de ensamble con una manta o alfombra. De este modo, se evitan daños en las piezas durante el proceso de montaje.



## Evite acidentes Avoid accidents Prevenir accidentes

Solicitamos observar atentamente as orientações de montagem como: fixação do produto na parede, colocação de cola em locais específicos necessários, o peso suportado pelo produto, etc...

We request you to carefully observe the assembly instructions as: fixing the product on the wall, adding glue in needed and specific places, product weight limit, etc.

Pedimos que lea atentamente las instrucciones, principalmente las informaciones de fijación del producto en la pared, colocación de pegamento en local específico y necesario, el peso soportado por el producto etc...

Não escale ou se apoie no móvel.

Do not climb or lean on the furniture.

No se suba ni se apoye en el mueble.

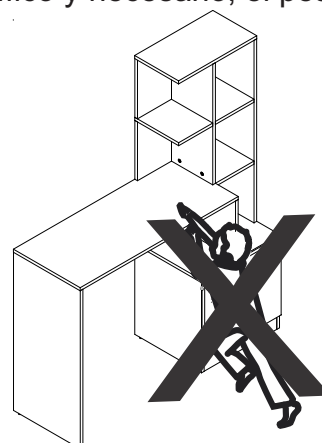

Dimensões e ferramentas  
Dimensions and tools  
Dimensiones y herramientas

Dimensões:

L: 1135 A: 1380 P: 395 mm

Dimensions:

W: 44.68 H: 54.33 D: 15.55 inches

Dimensiones:

L: 1135 A: 1380 P: 395 mm

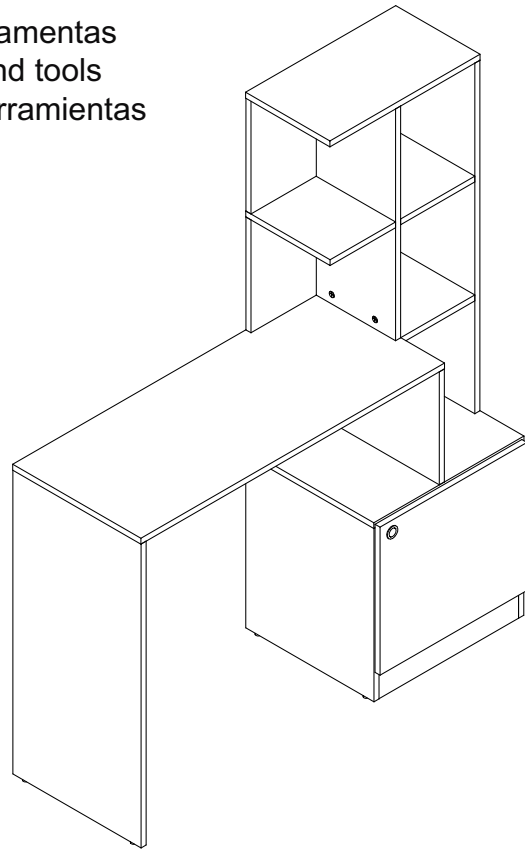

Limpeza  
Cleaning  
Limpieza

Pano levemente umedecido com água, seguido de pano seco, não utilizar produtos químico ou abrasivos.  
You can clean the product with slightly dampened cloth followed by a dry cloth. Do not use chemicals or abrasives.  
Solamente utilizar un paño húmedo y después un paño seco, no utilice productos químicos o abrasivos.

Todas as peças do móvel foram marcadas com um número. Antes de começar a montagem, identifique as peças numeradas em relação às instruções de montagem. Uma vez concluída a montagem, os números podem ser facilmente removidos com um pano ligeiramente embebido em álcool. Use álcool apenas para remover números das peças.

All the furniture parts have been marked with a number. Before you start assembling, please identify the numbered parts in relation to the assembly instructions. Once assembly is completed, the numbers can be easily removed with a cloth slightly damped in alcohol. Use alcohol only to remove part numbers.

Todos las piezas del mueble fueron marcadas con un número. Antes de empezar el montaje, identifique las piezas numeradas en relación con las instrucciones de montaje. Una vez que se completa el armado, los números se pueden quitar fácilmente con un paño ligeramente empapado en alcohol. Use alcohol solo para eliminar números de las piezas.

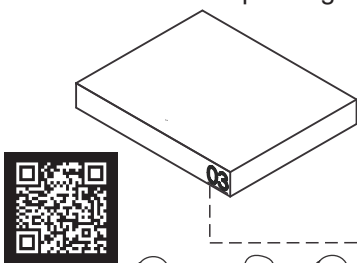

**UTILIZE ALCOOL APENAS PARA REMOVER O NUMERO DAS PEÇAS**  
**USE ALCOHOL ONLY TO REMOVE PART NUMBERS**  
**UTILICE ALCOHOL SOLAMENTE PARA ELIMINAR EL NUMERO DE LAS PIEZAS**

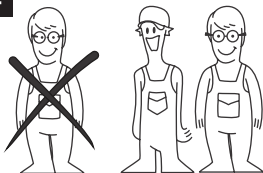

Para facilitar a montagem, utilize uma parafusadeira elétrica.  
To speed assembly, use an electronic screwdriver.  
Para facilitar el armado, utilice un destornillador eléctrico.

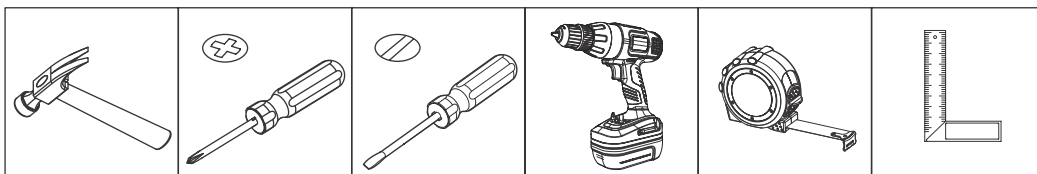

# COD BR: BC 85

PEÇA	DESCRIÇÃO	QUANT.
001	TAMPO MAIOR	1
002	LATERAL ESQUERDA	1
003	TRAVESSA	1
004	LATERAL MENOR	1
005	LATERAL DIREITA SUPERIOR	1
006	TAMPO MENOR	1
007	DIVISÓRIA	1
008	PRATELEIRA MAIOR SUPERIOR	1
009	PRATELEIRA MAIOR INFERIOR	1
010	PRATELEIRA MENOR	1
011	COSTA 15mm	2
012	LATERAL DIREITA INFERIOR	1
013	LATERAL ESQUERDA INFERIOR	1
014	RODAPE	1
015	PORTA	1
016	BASE	1
017	COSTA	1
018	TAMPO INTERMEDIÁRIO	1

PART	DESCRIPTION	QTY
001	LONGER TOP	1
002	LEFT SIDE	1
003	TRAVERSE	1
004	LOWER SIDE	1
005	UPPER RIGHT SIDE	1
006	LOWER TOP	1
007	PARTITION	1
008	LARGER TOP SHELF	1
009	LARGER LOWER SHELF	1
010	SMALLER SHELF	1
011	BACK 0,59 in	2
012	LOWER RIGHT SIDE	1
013	LOWER LEFT SIDE	1
014	BASEBOARD	1
015	DOOR	1
016	BASE	1
017	BACK	1
018	INTERMEDIARY TOP	1

PIEZA	DESCRIPCIÓN	CANTIDAD
001	TAPA MENOR	1
002	LATERAL IZQUIERDA	1
003	TRAVESAÑO	1
004	LATERAL MENOR	1
005	LATERAL DERECHA SUPERIOR	1
006	TAPA MENOR	1
007	PARTICIÓN	1
008	REPISA MAYOR SUPERIOR	1
009	REPISA MAYOR INFERIOR	1
010	REPISA MENOR	1
011	REVÉS 15mm	2
012	LATERAL DERECHA INFERIOR	1
013	LATERAL IZQUERDA INFERIOR	1
014	RODAPIE	1
015	PUERTA	1
016	BASE	1
017	REVÉS	1
018	REVÉS CAJÓN	2

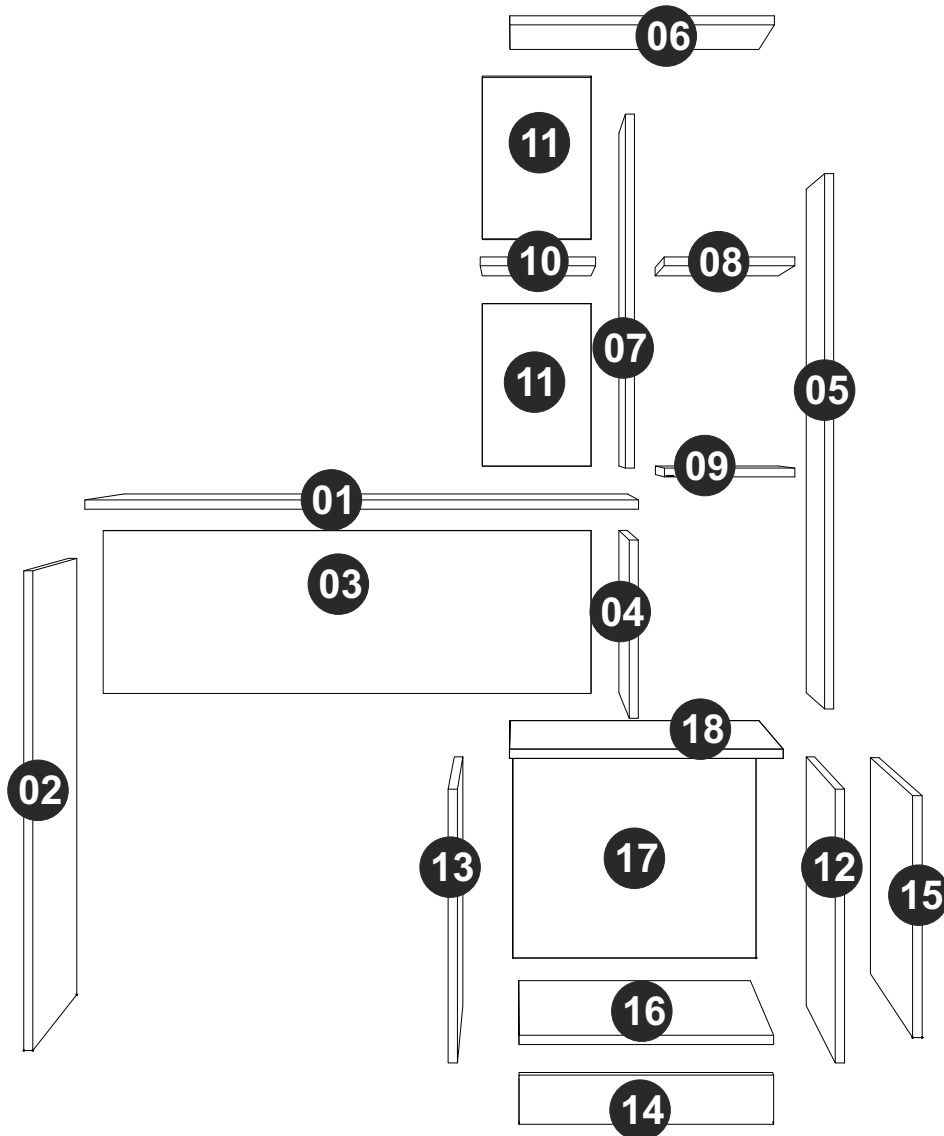

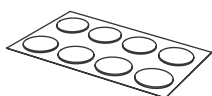

TAPA FUROS x 33  
STICKER x 33  
TAPAS PLÁSTICAS x 33



EF 000731 X 8  
8x55



EF 000724 X 2  
8x40



EF 000033x 29  
8x30



GIZ x 01  
CHALK x 01  
TIZA x 01



EF 000216 X 33



EF 000094 X 21



PÉS REDONDOS x 6  
ROUND FEET x 6  
PIES REDONDOS x 6

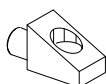

EF 000714 X 02



EF 000168 X 24  
10X10 C/C



PUXADOR x 1  
HANDLE x 1  
MANIJA x 1

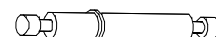

EF 000067 X 6



EF 000106 x 12  
3,5X14 CC



EF 000132 x 4  
4X50 CC

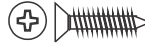

EF 000107 x 2  
3,5X16 CC



SUPORTE ANGULAR X 2  
ANGULAR SUPPORT X 2  
SOPORTE ANGULAR X 2

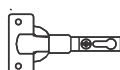

EF 000044 X 2



EF 000024 X 2

Utilize para medir as ferragens.

Utilice para medir el herraje.

Use for measuring the hardware.

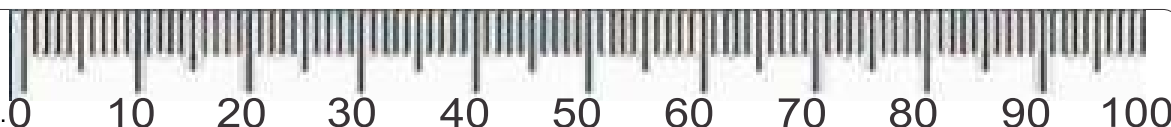

**Garantia (exclusivo para o Brasil/exclusivo de Brasil/exclusive to Brazil):**

A garantia dos produtos fabricados pela BRV Móveis, abrange eventuais defeitos-vícios de fabricação, no prazo estabelecido pelo código de Defesa do Consumidor, em seu artigo 26.II. o qual prevê a garantia de 90 (noventa) dias.

**A** = 12KG - 26.45LB

**B** = 5KG - 11.02LB

**C** = 1KG - 2.20LB

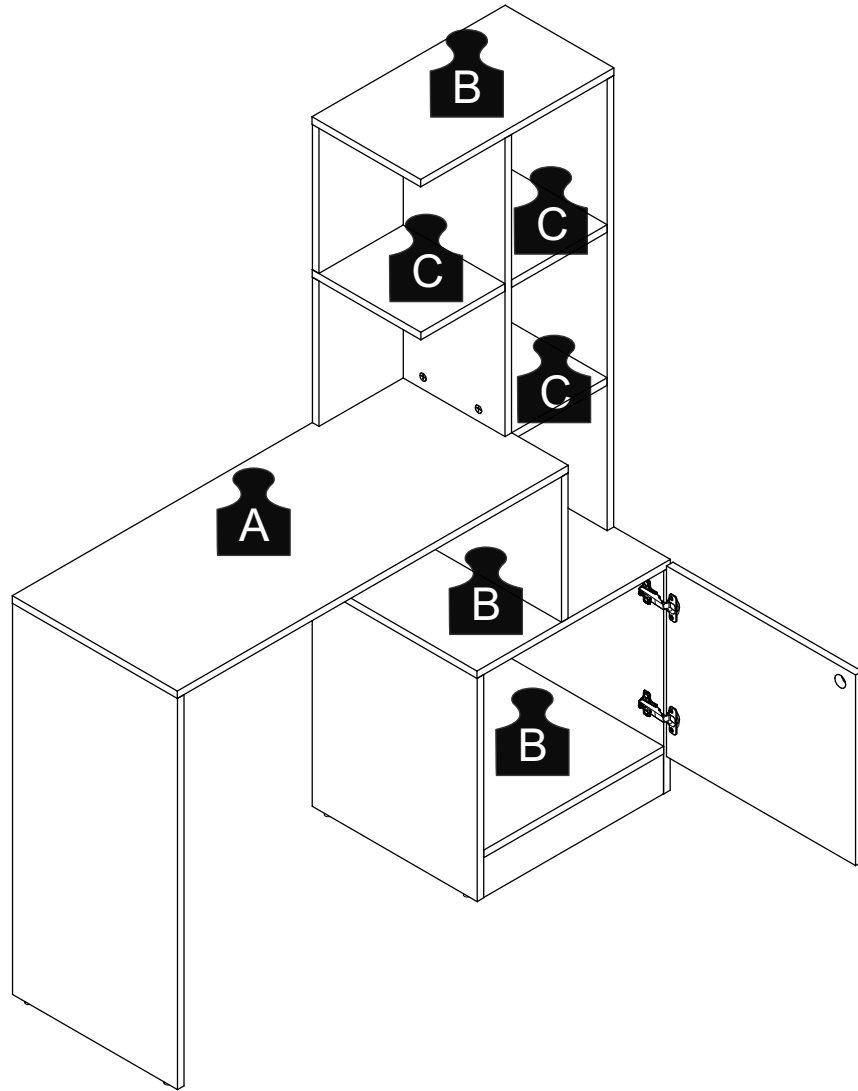

**PASSO 1 / STEP 1 / PASO 1**

Fixe a ferragem EF 000094 nas peças 01, 06 e 18.  
Attach hardware EF 000094 in pieces 01, 06 and 18.  
Fije el herraje EF 000094 en las piezas 01, 06 y 18.

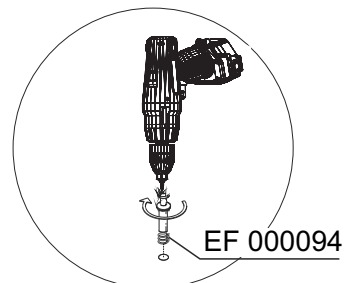
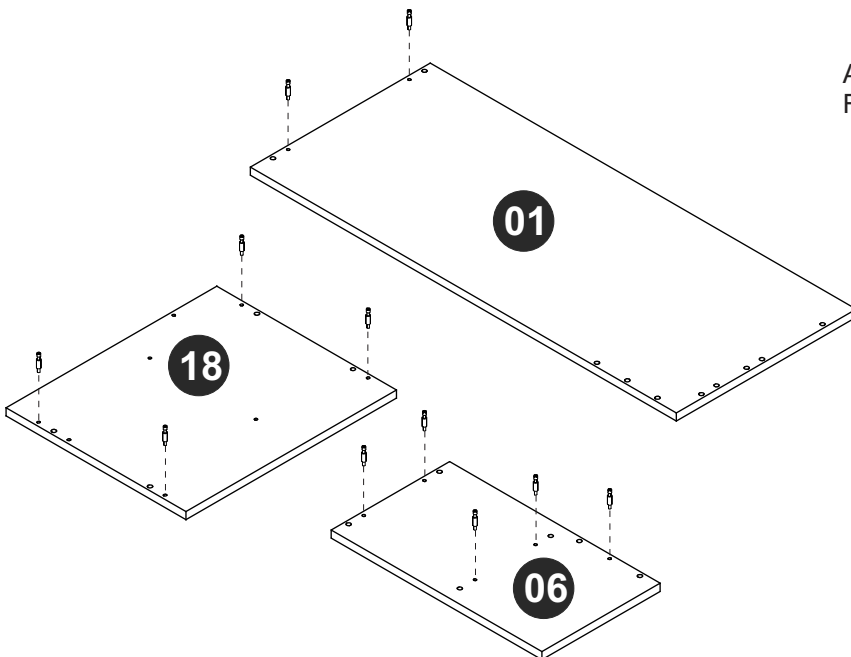

Não insira a ferragem EF 000033 aqui.  
Do not insert hardware EF 000033 here  
No añade el herraje EF 000033 aquí.

## PASSO 2 / STEP 2 / PASO 2

Insira a ferragem EF 000033 nas peças 03, 04, 10 e 16.  
Insert hardware EF 000033 into pieces 03, 04, 10 and 16.  
Añade el herraje EF 000033 en las piezas 03, 04, 10 y 16.

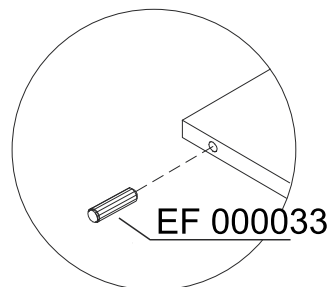
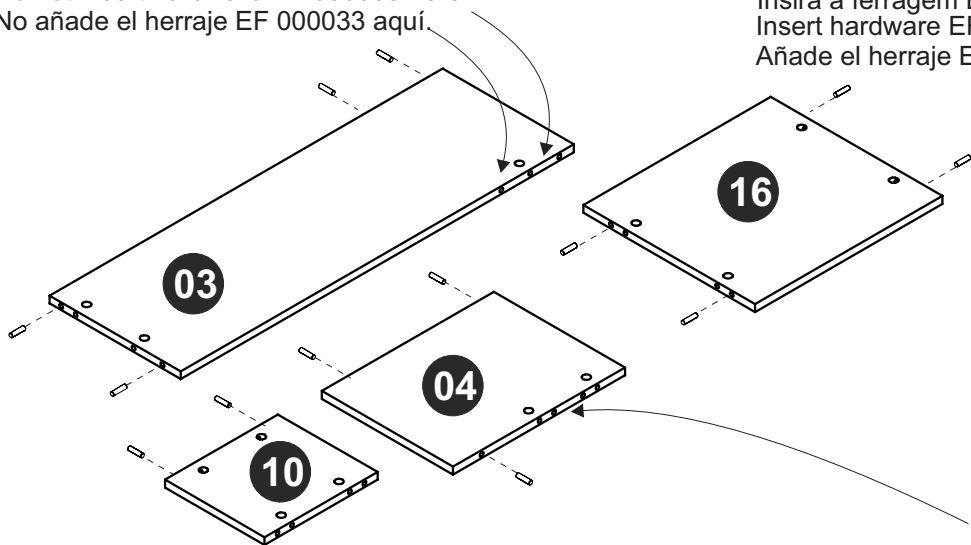

Não insira a ferragem EF 000033 aqui.  
Do not insert hardware EF 000033 here  
No añade el herraje EF 000033 aquí.

## PASSO 3 / STEP 3 / PASO 3

Insira a ferragem EF 000033 e EF 000094 nas peças 02 e 05.  
Insert hardware EF 000033 and EF 000094 in pieces 02 and 05.  
Añade el herraje EF 000033 y EF 000094 en las piezas 02 y 05.

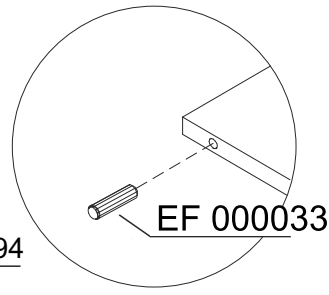
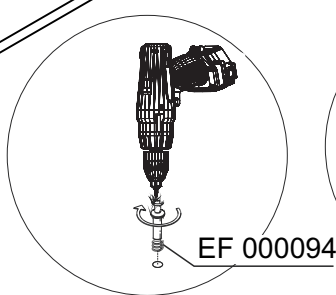
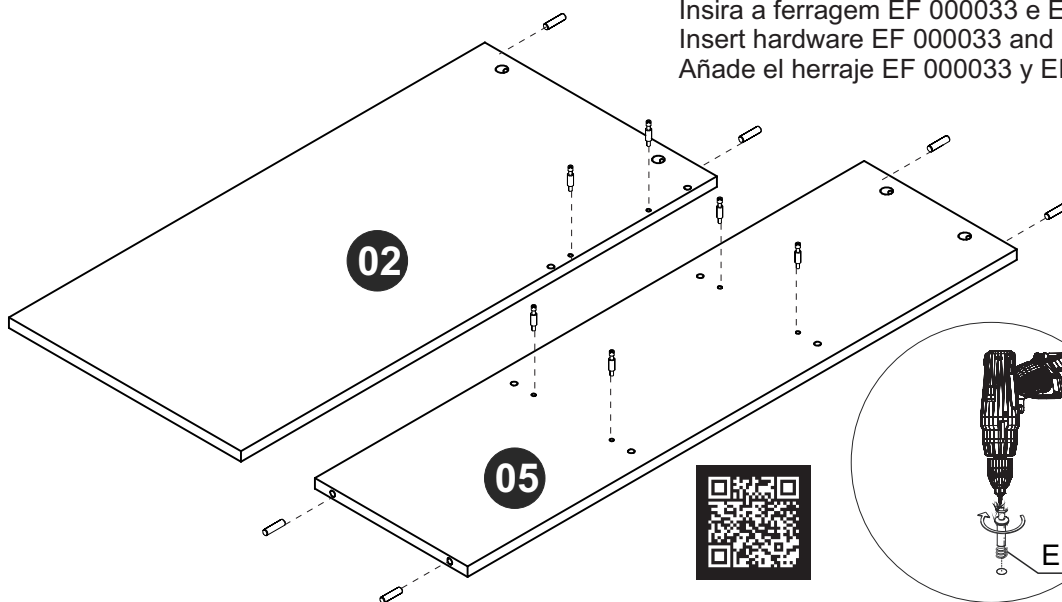

## PASSO 4 / STEP 4 / PASO 4

Insira a ferragem EF 000714 e EF 000033 nas peças 12 e 13. Fixe a ferragem EF 000024 na peça 12 utilizando a ferragem EF 000106.  
Insert hardware EF 000714 and EF 000033 into pieces 12 and 13. Attach hardware EF 000024 to piece 13 using hardware EF 000106.  
Añade el herraje EF 000714 y EF 000033 en las piezas 12 y 13. Fije el herraje EF 000024 en la pieza 12 utilizando el herraje EF 000106.

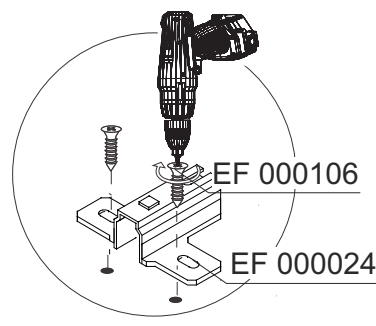
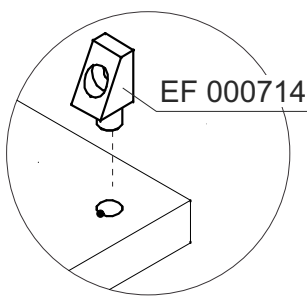
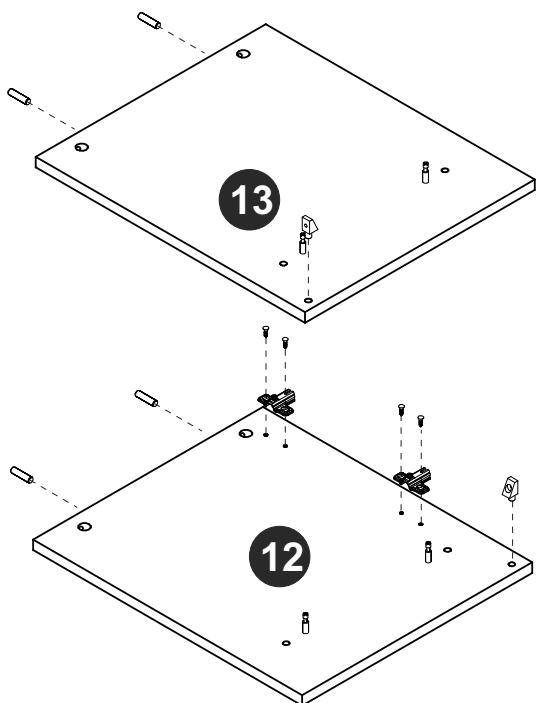

## PASSO 5 / STEP 5 / PASO 5

Fixe a ferragem EF 000044 na peça 15 utilizando a ferragem EF 000106.  
Attach hardware EF 000044 to piece 15 using hardware EF 000106.  
Fije el herraje EF 000044 en la pieza 15 utilizando el herraje EF 000106.

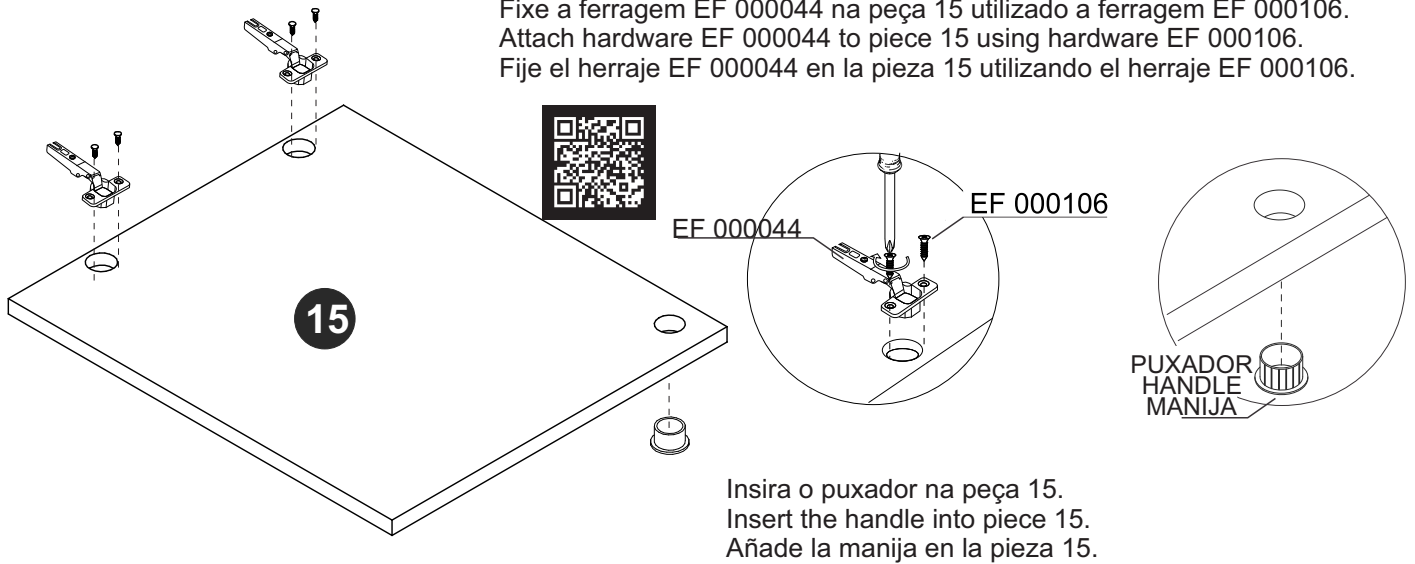

## PASSO 6 / STEP 6 / PASO 6

Encaixe o suporte angular na ranhura da peça 14, fixe à peça 16 usando a ferragem EF 000106.  
Fit the angular support at indicated space in piece 14, fix to piece 16 using hardware EF 000106.  
Encaste el soporte angular en las ranuras de la pieza 14, fije a la pieza 16 con el herraje EF 000106.

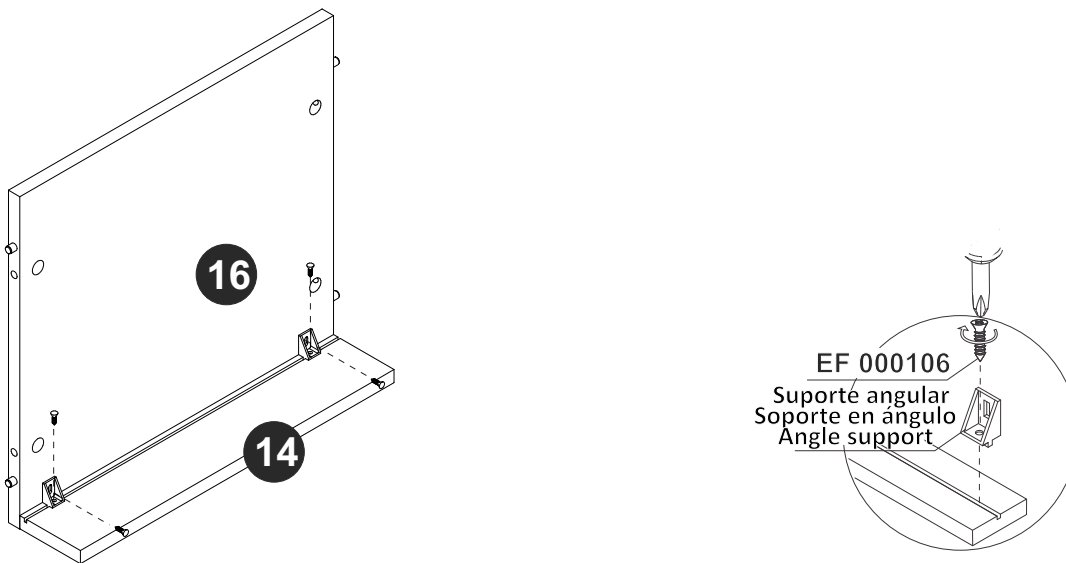

## PASSO 7 / STEP 7 / PASO 7

Insira a ferragem EF 000033 aqui.  
Insert hardware EF 000033 here  
Añade el herraje EF 000033 aquí.

Use as ferragens EF 000067 e EF 000731 para conectar as peças 10 e 11.  
Use hardware EF 000067 and EF 000731 to connect pieces 10 and 11.  
Utilice los herrajes EF 000067 y EF 000731 para juntar las piezas 10 y 11.

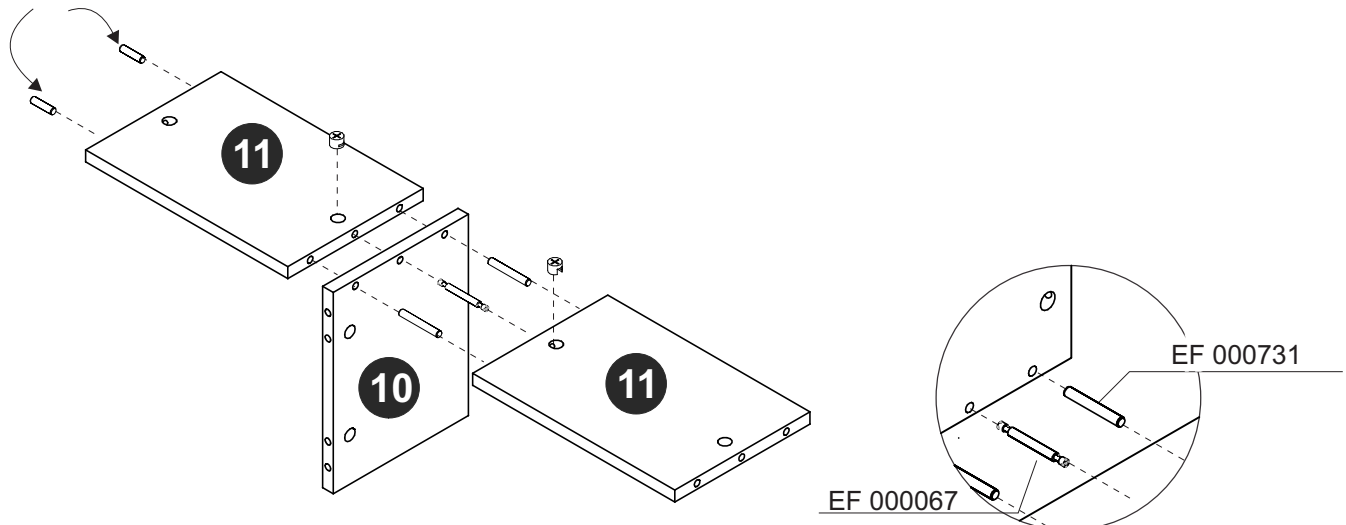

### PASSO 8 / STEP 8 / PASO 8

Use as ferragens EF 000067 e EF 000731 para conectar as peças 07, 08 e 10.  
Use hardware EF 000067 and EF 000731 to connect pieces 07, 08 and 10.  
Utilice los herrajes EF 000067 y EF 000731 para juntar las piezas 07, 08 y 10.

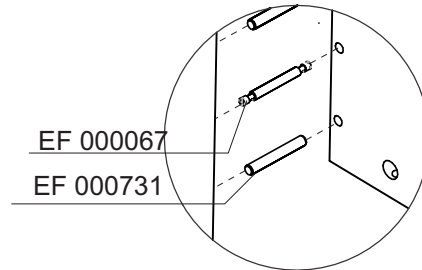
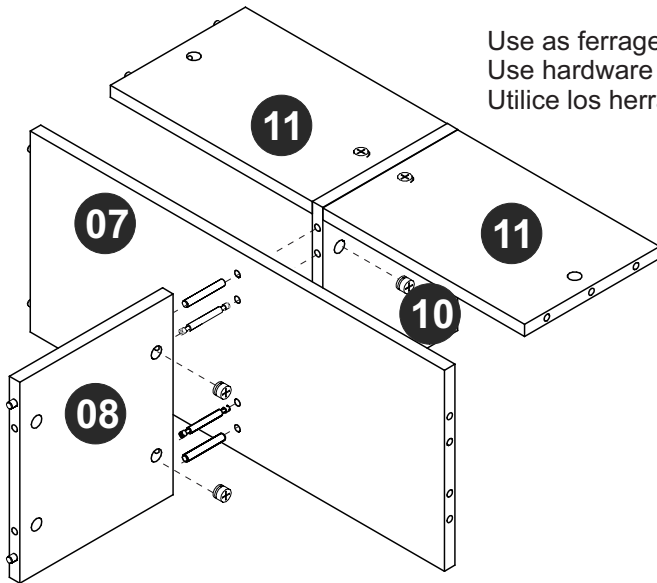

EF 000067  
EF 000731

### PASSO 9 / STEP 9 / PASO 9

Conecte as peças 02 e 03, insira a ferragem EF 000216 e gire para apertar.  
Connect pieces 02 and 03, insert hardware EF 000216 and turn to tighten.  
Junte las piezas 02 y 03, añada el herraje EF 000216 y gire para apretar.

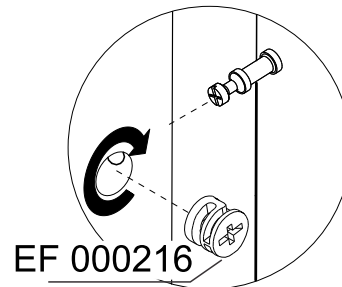
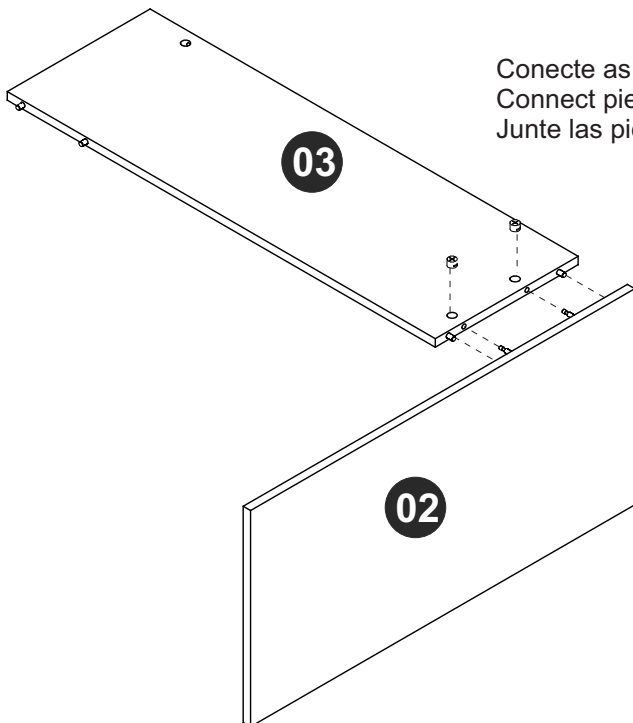

EF 000216

### PASSO 10 / STEP 10 / PASO 10

Conecte as peças 01 e 04, insira a ferragem EF 000216 e gire para apertar.  
Connect pieces 01 and 04, insert hardware EF 000216 and turn to tighten.  
Junte las piezas 01 y 04, añada el herraje EF 000216 y gire para apretar.

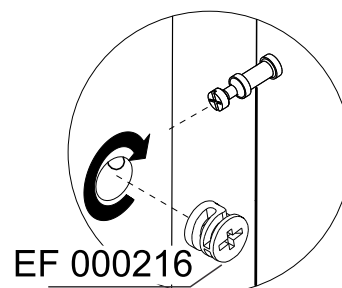
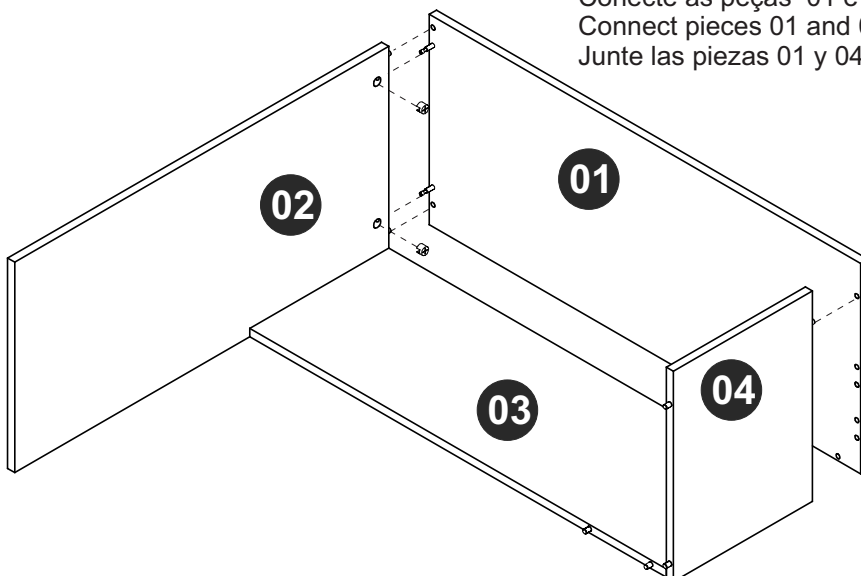

EF 000216

### PASSO 11 / STEP 11/ PASO 11

Use as ferragens EF 000067 e EF 000731 para conectar as partes montadas nos passos 8 e 10, insira a ferragem EF 000216 e gire para apertar.  
Use hardware EF 000067 and EF 000731 to connect the parts assembled in steps 8 and 10, insert hardware EF 000216 and turn to tighten.  
Utilice los herrajes EF 000067 y EF 000731 para juntar las partes armadas en los pasos 8 y 10, añada el herraje EF 000216 y gire para apretar.

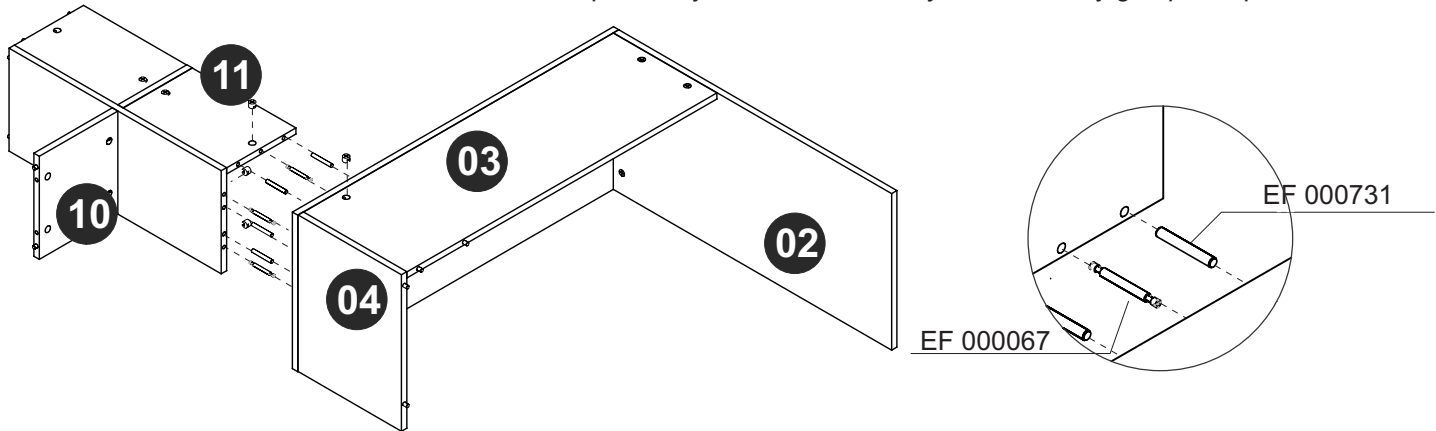

### PASSO 12 / STEP 12 / PASO 12

Insira a ferragem EF 000724 para conectar a peça 09.  
Insert hardware EF 000724 to connect piece 09.  
Añade el herraje EF 000724 para juntar la pieza 09.

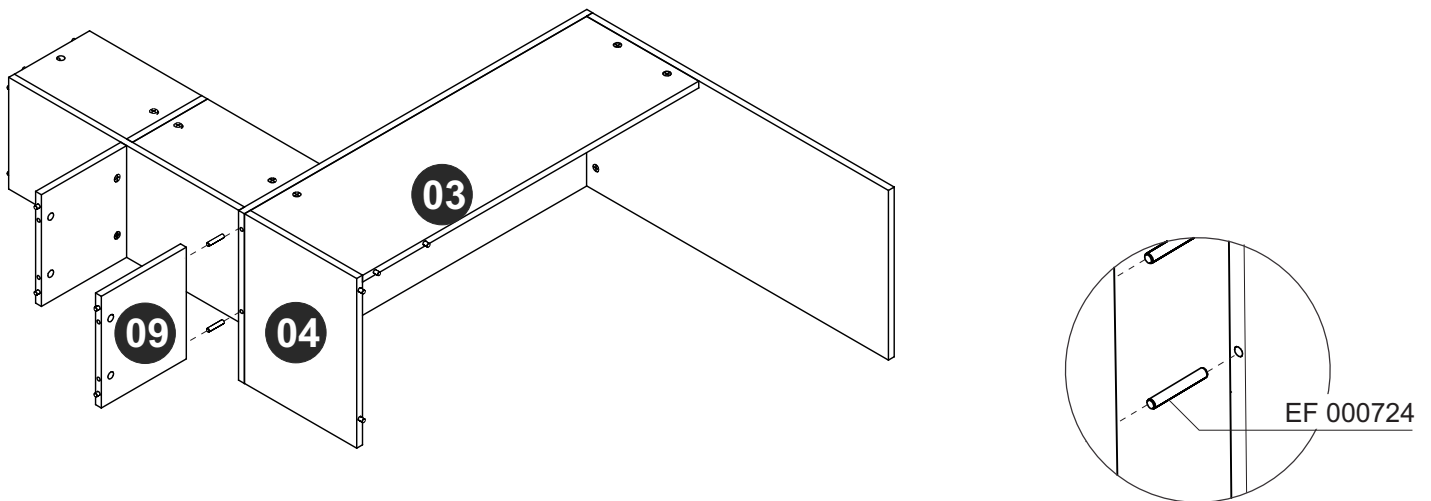

### PASSO 13 / STEP 13 / PASO 13

Conecte a peça 05, insira a ferragem EF 000216 e gire para apertar.  
Connect piece 05, insert hardware EF 000216 and turn to tighten.  
Junte la pieza 05, añada el herraje EF 000216 y gire para apretar.

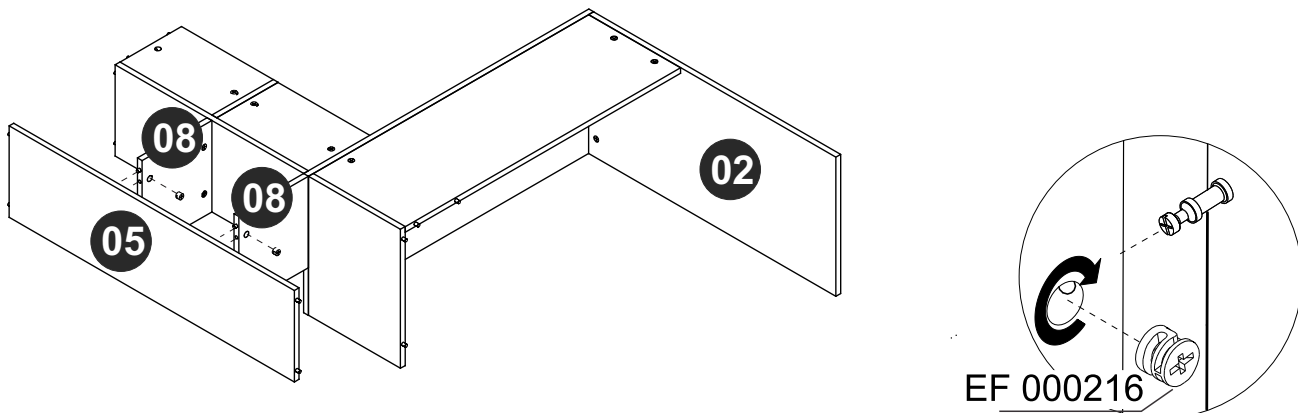

### PASSO 14 / STEP 14/ PASO 14

Conecte a peça 06, insira a ferragem EF 000216 e gire para apertar.  
Connect piece 06, insert hardware EF 000216 and turn to tighten.  
Junte la pieza 06, añade el herraje EF 000216 y gire para apretar.

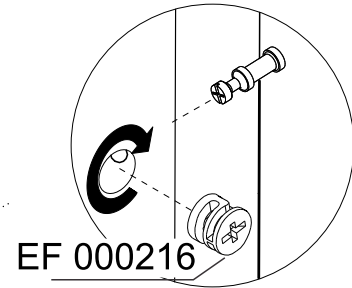
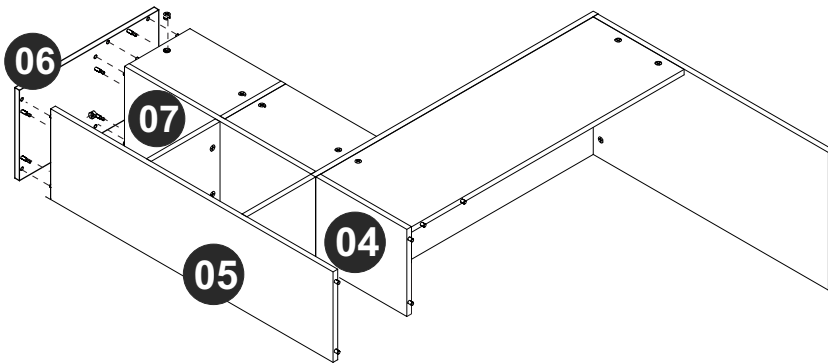

### PASSO 15 / STEP 15 / PASO 15

Fixe a peça 18 utilizando a ferragem EF 000132.  
Attach piece 18 using hardware EF 000132.  
Fije la pieza 18 utilizando el herraje EF 000132.

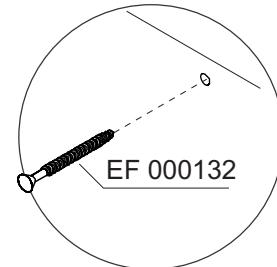
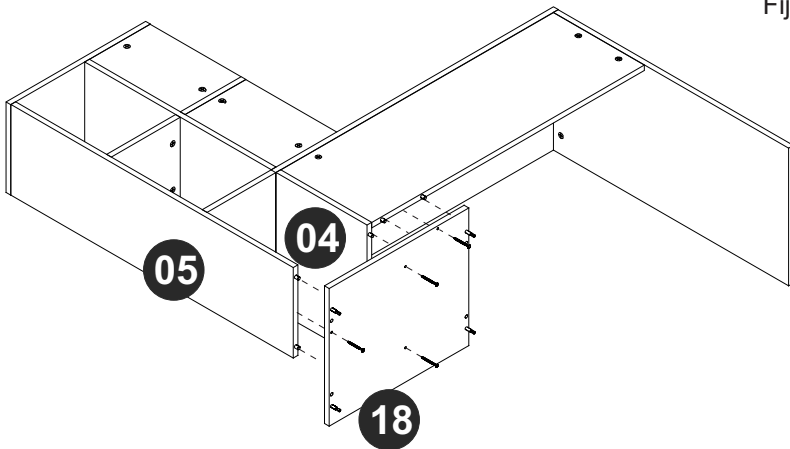

### PASSO 16 / STEP 16 / PASO 16

Conecte as peças 12, 13, 14 e 16, insira a ferragem EF 000216 e gire para apertar.  
Fixe a ferragem EF 000714 à peça 14 utilizando a ferragem EF 000107.  
Connect pieces 12, 13, 14 and 16 using hardware EF 000216 and turn to tighten.  
Attach hardware EF 000714 to piece 14 using hardware EF 000107.  
Junte las piezas 12, 13, 14 y 16, añade el herraje EF 000216 y gire para apretar.  
Fije el herraje EF 000714 a la pieza 14 utilizando el herraje EF 000107.

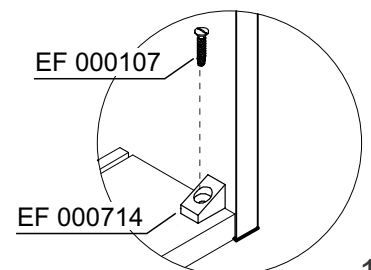
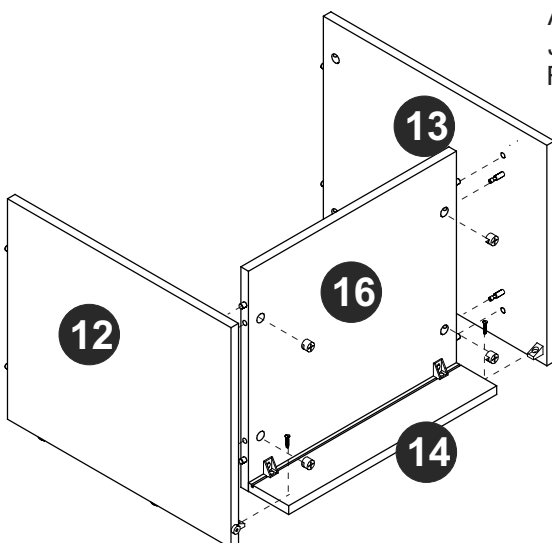

### PASSO 17 / STEP 17 / PASO 17

Conecte a peça 18, insira a ferragem EF 000216 e gire para apertar.  
Connect piece 18, insert hardware EF 000216 and turn to tighten.  
Junte la pieza 18, añáde el herraje EF 000216 y gire para apretar.

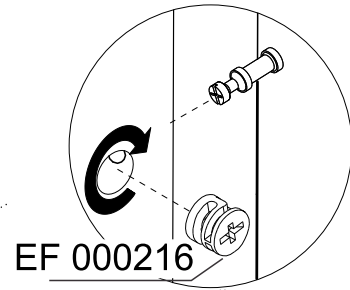
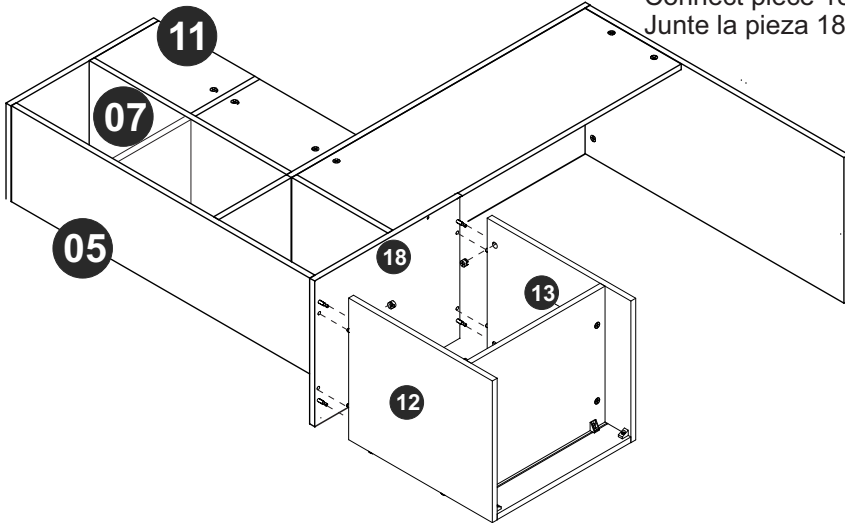

### PASSO 18 / STEP 18 / PASO 18

Conecte a peça 06, insira a ferragem EF 000216 e gire para apertar.  
Connect piece 06, insert hardware EF 000216 and turn to tighten.  
Junte la pieza 06, añáde el herraje EF 000216 y gire para apretar.

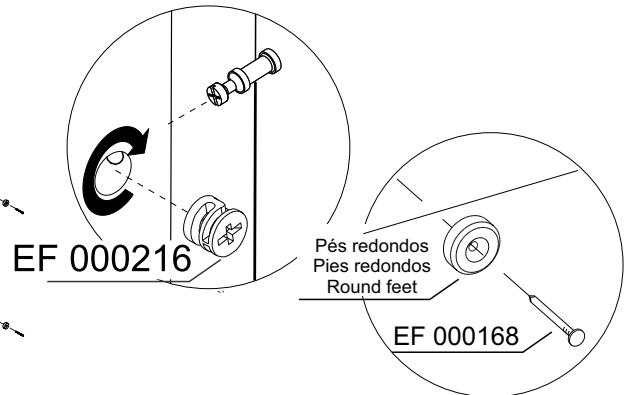
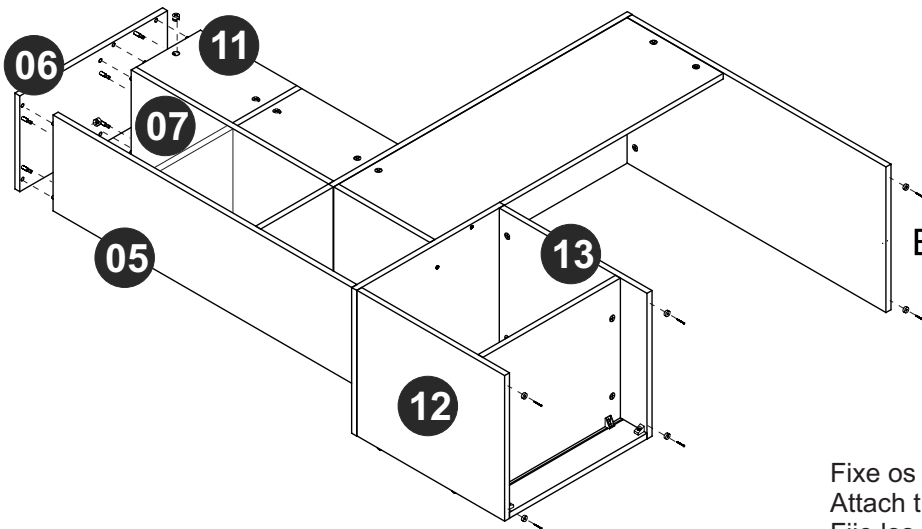

Fixe os pés utilizando a ferragem EF 000168.  
Attach the feet using hardware EF 000168.  
Fije los pies utilizando el herraje EF 000168.

### PASSO 19 / STEP 19 / PASO 19

Fixe a peça 17 utilizando a ferragem EF 000168.  
Attach piece 17 using hardware EF 000168.  
Fije la pieza 17 utilizando el herraje EF 000168.

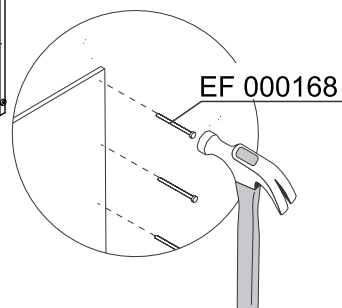
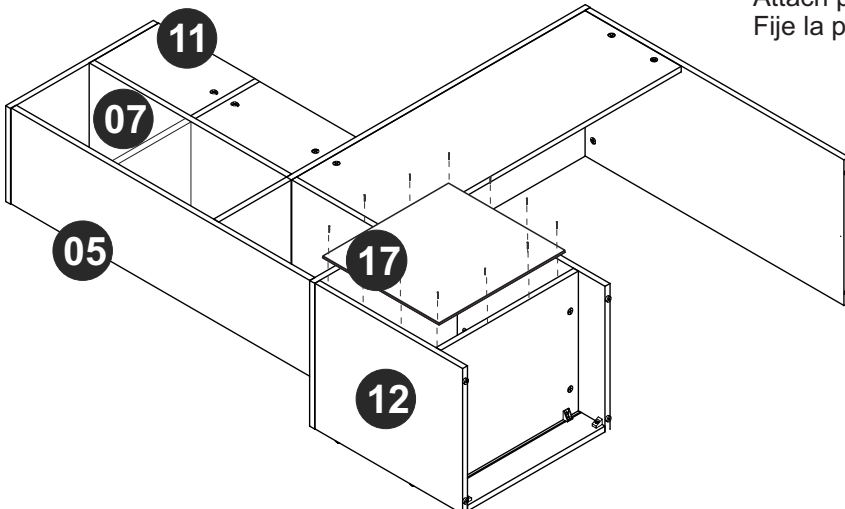

## PASSO 20 / STEP 20 / PASO 20

Fixe a peça 15 ao móvel montado, gire o parafuso para ajustar a porta conforme necessário.  
Attach piece 15 to assembled furniture, turn the screw for adjusting the door as needed.  
Fije la pieza 15 al mueble armado, gire el tornillo para ajustar la puerta según sea necesario.

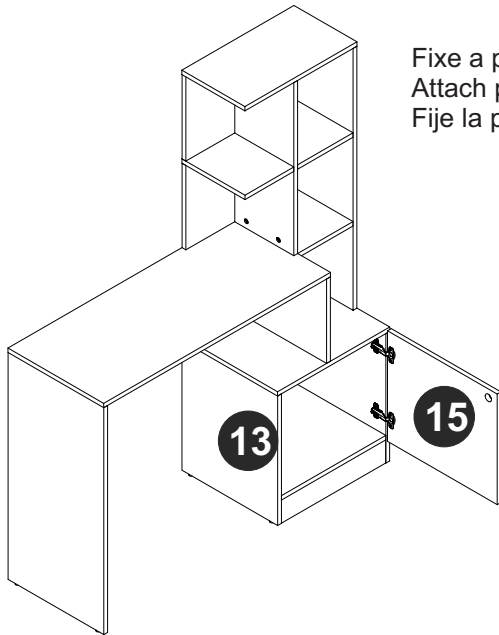

Ajuste de profundidade  
Deph  
adjusting  
Ajuste de  
profundidad

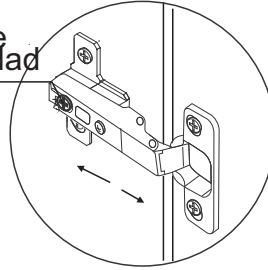

## PASSO 21 / STEP 21 / PASO 21

Solte o parafuso para ajustar a porta conforme necessário.  
Release the screw for adjusting the door as needed.  
Suelete el tornillo para ajustar la puerta según sea necesario.

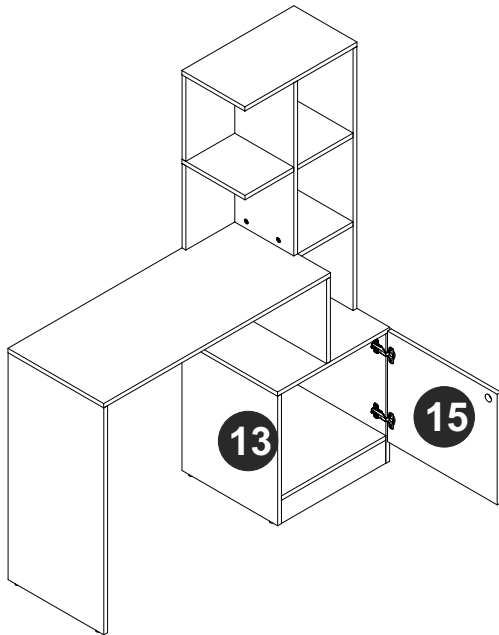

Ajuste Vertical  
Vertical adjusting

Ajuste horizontal  
Horizontal adjusting

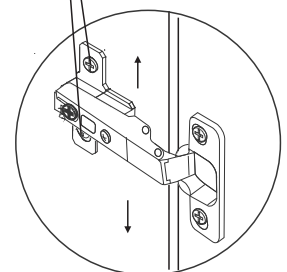
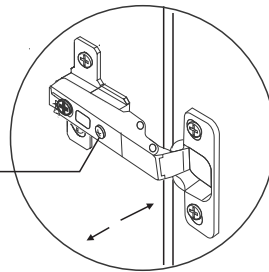

## PASSO 22 / STEP 22 / PASO 22

Use o giz para dar o acabamento final ao produto. Use os tapa furos para cobrir os parafusos aparentes.  
Use the chalk to give the final finish on the product. Use stickers to cover apparent screws.  
Utilice la tiza para dar el acabado final al producto. Utilice los tapa huecos para cubrir los tornillos aparentes.

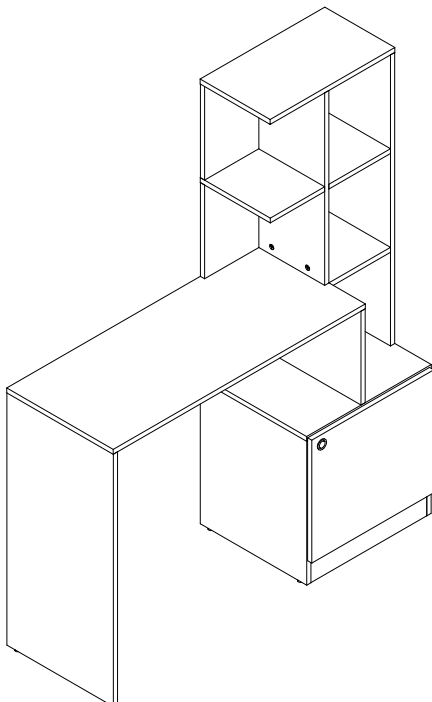

Giz  
Chalk  
Tiza

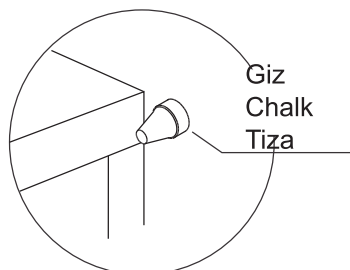

Tapa furos  
Sticker  
Tapas Plasticas

