

## YOU WILL NEED

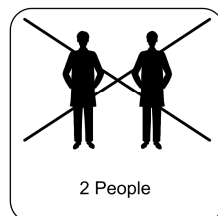

## Tools not included

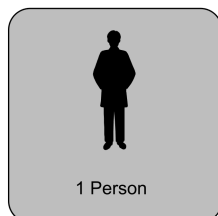
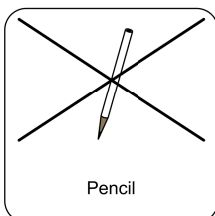
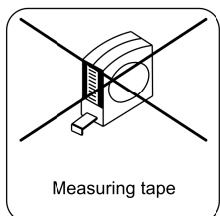
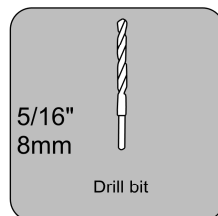
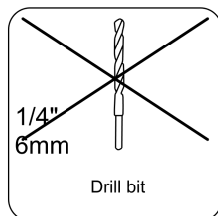
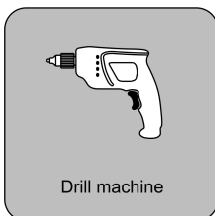
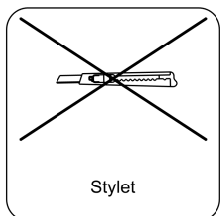
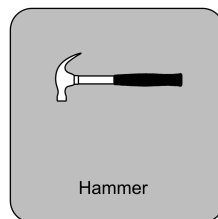
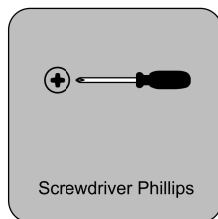
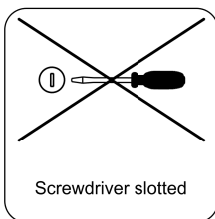
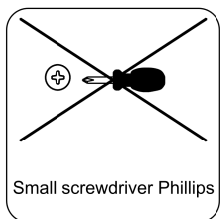
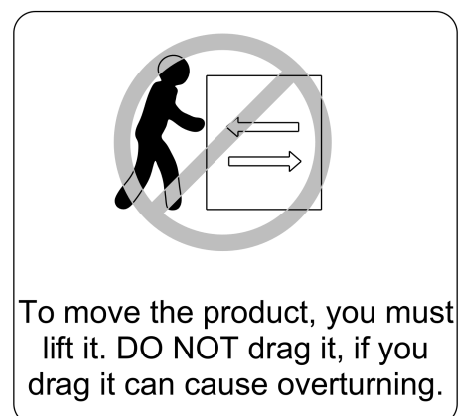
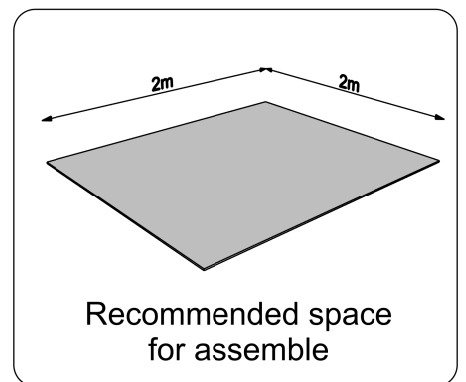

# PARTS IDENTIFICATION

<b>01</b>	Top Plan de Travail Tapa Tampo	Qty./Qtd. <b>01</b>
<b>02</b>	Base Base Base Base	Qty./Qtd. <b>01</b>
<b>03</b>	Left Side Côté Gauche Lateral Izquierdo Lateral Esquerda	Qty./Qtd. <b>01</b>
<b>04</b>	Division Division División Divisória	Qty./Qtd. <b>01</b>
<b>05</b>	Right Side Côté Droite Lateral Derecho Lateral Direita	Qty./Qtd. <b>01</b>
<b>06</b>	Panel Panneau Panel Painel	Qty./Qtd. <b>01</b>
<b>07</b>	Left Drawer Front Avant de Tiroir Gauche Frente del Cajón Izquierdo Frente de Gaveta Esquerda	Qty./Qtd. <b>01</b>
<b>08</b>	Right Drawer Front Avant de Tiroir Droite Frente del Cajón Derecho Frente de Gaveta Direita	Qty./Qtd. <b>01</b>
<b>09</b>	Rear of Drawer Arrière du Tiroir Posterior de Cajón Traseiro de Gaveta	Qty./Qtd. <b>02</b>
<b>10</b>	Left Side of Drawer Côté Gauche du Tiroir Lateral Izquierdo de Cajón Lateral Esquerda de Gaveta	Qty./Qtd. <b>02</b>
<b>11</b>	Right Side of Drawer Côté Droite du Tiroir Lateral Derecho de Cajón Lateral Direita de Gaveta	Qty./Qtd. <b>02</b>
<b>12</b>	Backboard of drawer Arrière du Tiroir Fondo de cajón Fundo de Gaveta	Qty./Qtd. <b>02</b>
<b>13</b>	Backboard Panneau Fondo Trasero Costa	Qty./Qtd. <b>01</b>

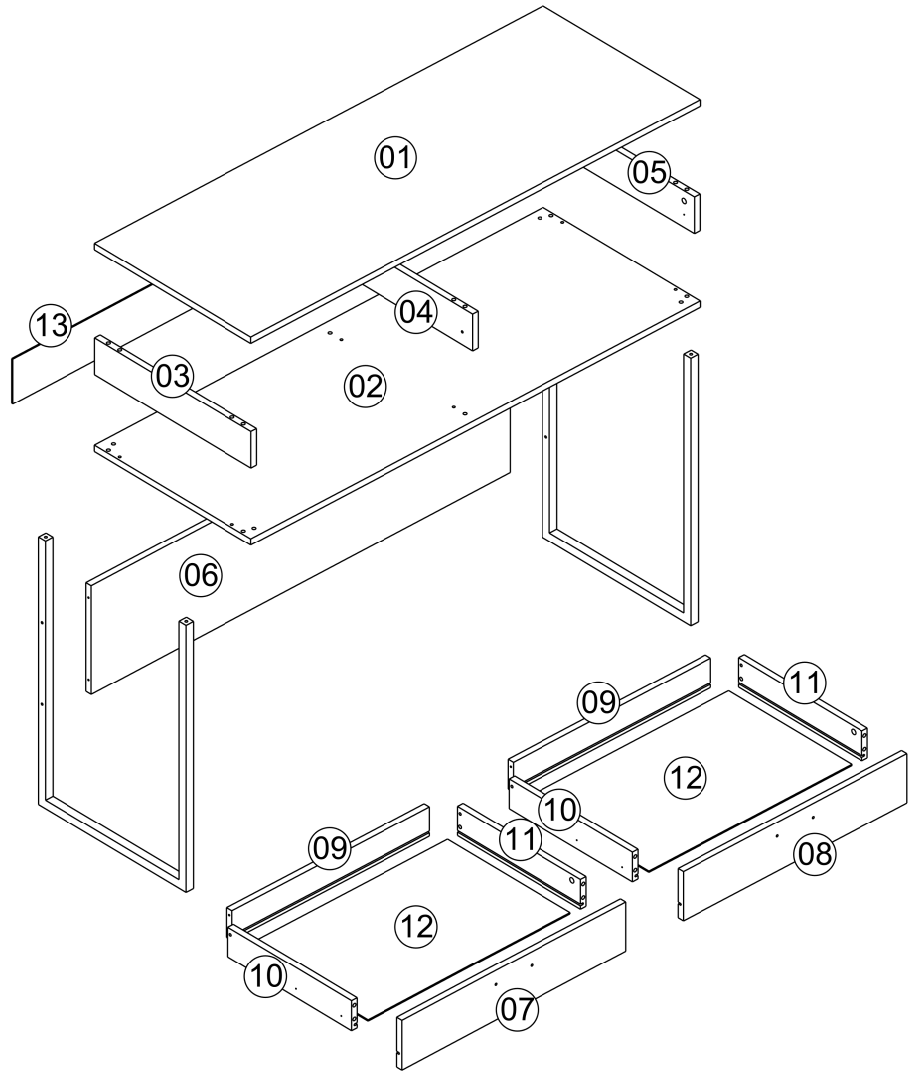

## GENERAL DIMENSIONS

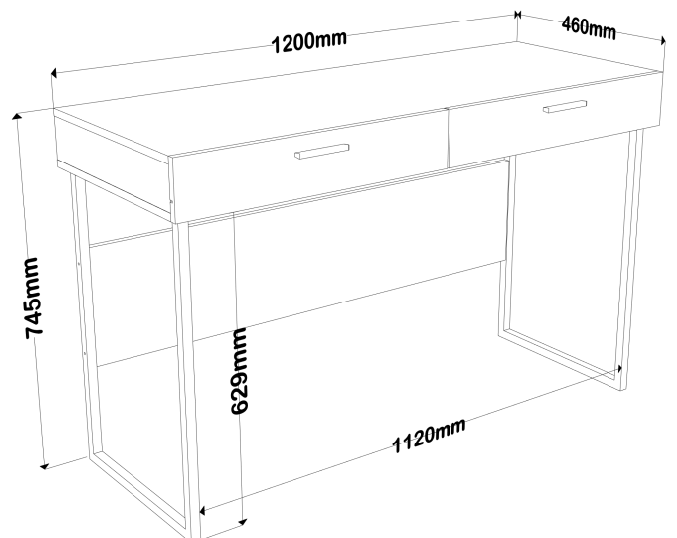
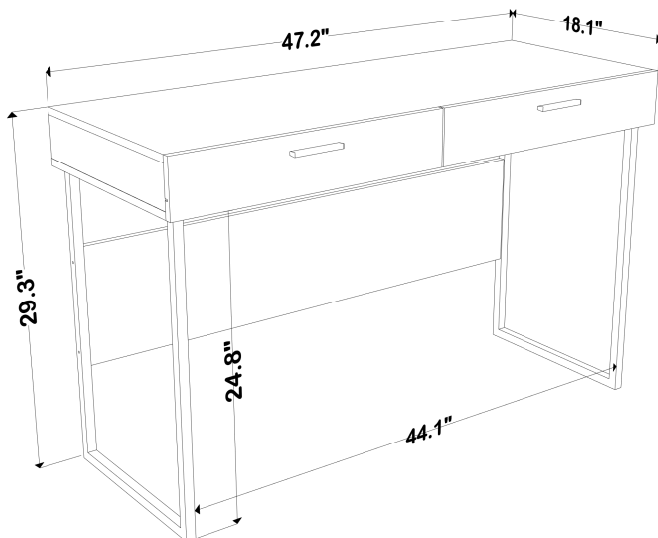



Dimensions are in Inches

# ACCESSORIES IDENTIFICATION

**A**  Qty./Qtd. **20**  
Wooden dowel / Chevilles en bois / Taquete / Caviha

**AJ**  Qty./Qtd. **4**  
Screw / Visser / Tornillo / Parafuso

**AK**  Qty./Qtd. **4**  
Flat head screw / Vis plate / Tornillo de cabeza plana / Parafuso cabeça chata

**AN**  Qty./Qtd. **4**  
Flanged head screw / Vis à tête bride / Tornillo de cabeza flangeada / Parafuso Flangeado

**AP**  Qty./Qtd. **4**  
Silicone stop / Butée en silicone / Tope de silicona / Batente de Silicone

**C**  Qty./Qtd. **10**  
Structural screw / Vis à tête structurelle / Tornillo estructural / Parafuso Estrutural

**D**  Qty./Qtd. **4**  
Flanged head screw / Vis à tête bride / Tornillo de cabeza flangeada / Parafuso Flangeado

**G**  Qty./Qtd. **10**  
Simple minifix screw / Vis minifix simple / Tornillo minifix simple / Haste Minifix Simples

**H**  Qty./Qtd. **10**  
Drum lock / Verrouillage du tambour / Tambor minifix / Tambor de Minifix

**i**  Qty./Qtd. **10**  
Bore patch adhesive / Adhésif de correction d'alésage / Tapones adhesivo/ Adesivo Tapa Furo

**J**  Qty./Qtd. **24**  
Nail / Ongle / Clavo / Prego

**K**  Qty./Qtd. **1**  
Glue / Colle / Pegamento / Bisnaga de Cola

**N**  Qty./Qtd. **14**  
Pan head screw / Vis à tête bombée / Tornillo de pan / Parafuso Panela

**R**  Qty./Qtd. **1**  
Metalic bracket / Support métallique / Soporte de metal / Suporte de Metal

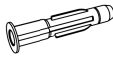
**S**  Qty./Qtd. **1**  
Bushing / Douille expansive / Tapón / Bucha Plástica

**T**  Qty./Qtd. **1**  
Flanged head screw / Vis à tête bride / Tornillo de cabeza flangeada/ Parafuso flangeado

Separating the accessories before starting the assembly will make it easier. In case of doubts about the size of the screws and wooden dowels, use the ruler at the end of this page.

**MAXIMUM RECOMMENDED WEIGHT BEING THIS EVENLY DISTRIBUTED.**

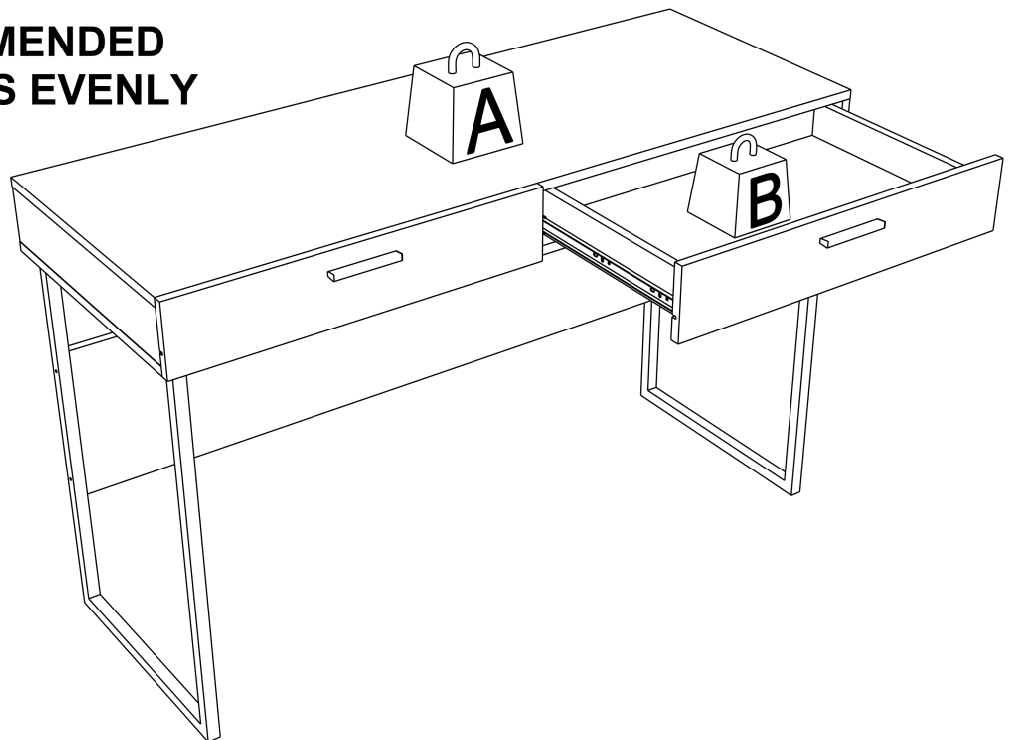

	LB	KG
<b>A</b>	55	25
<b>B</b>	11	5

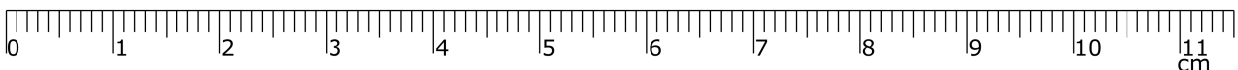

# PRE-ASSEMBLY

- 01 - Fix accessory (A) to part (09).  
Fixez l'accessoire (A) à la pièce (09).  
Fijar accesorio (A) a pieza (09).  
Fixe o acessório (A) na peça (09).

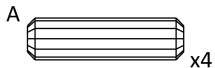
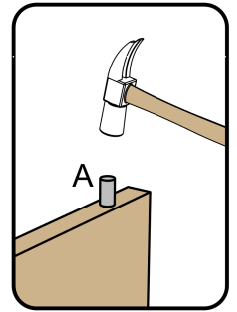
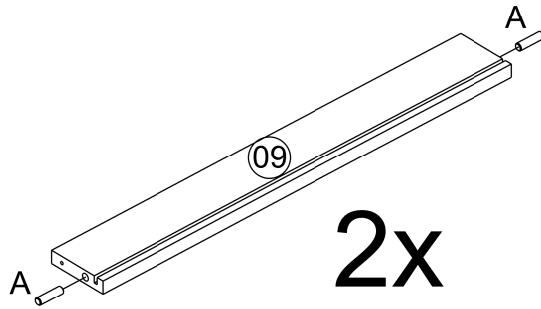

- 02 - Fix accessory (G) to part (01).  
Fixez l'accessoire (G) à la pièce (01).  
Fijar accesorio (G) a pieza (01).  
Fixe o acessório (G) na peça (01).

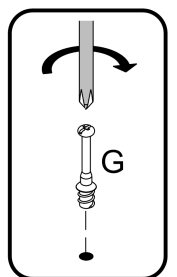
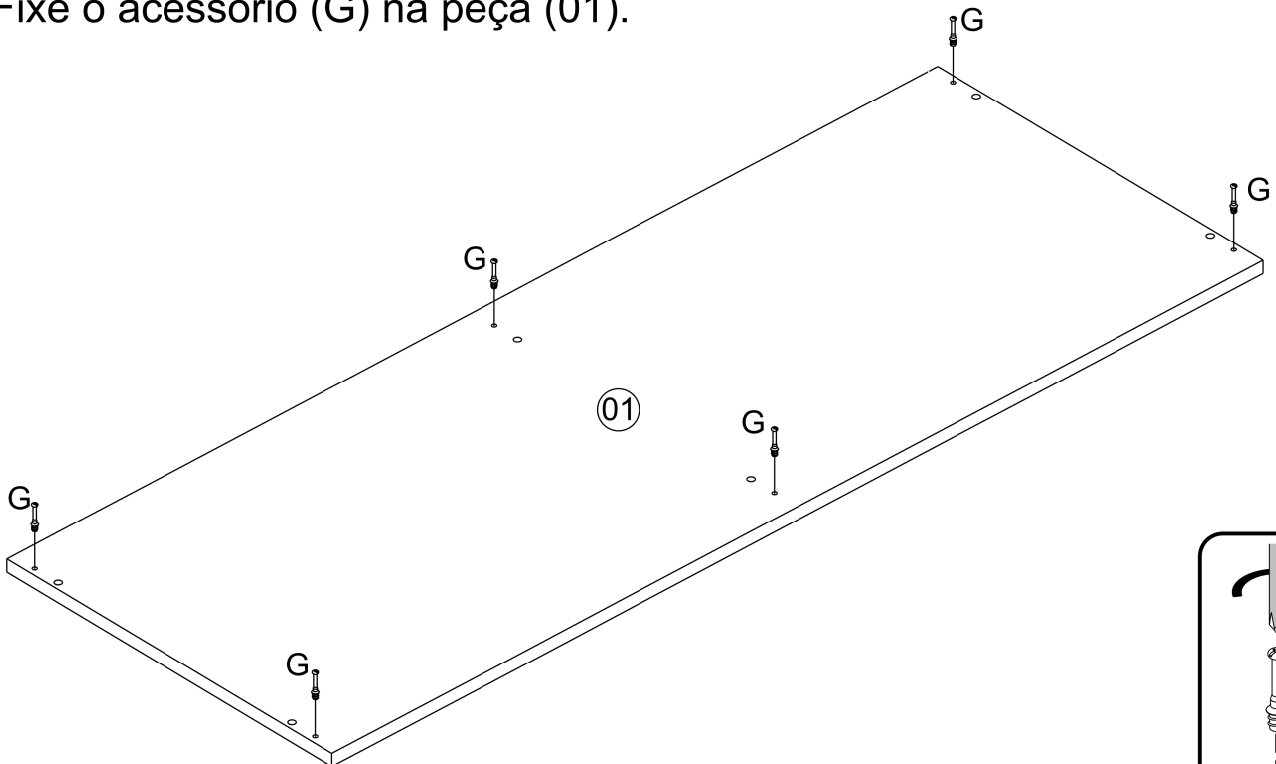

- 03 -** Fix accessory (A) and telescopic slides (Y1) to part (11).  
 Fixez l'accessoire (A) et les diapositives télescopiques (Y1) à la pièce (11).  
 Fijar accesorio (A) y correderas telescópicas (Y1) a pieza (11).  
 Fixe o acessório (A) e a corrediça telescópica (Y1) na peça (11).

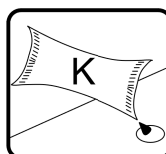
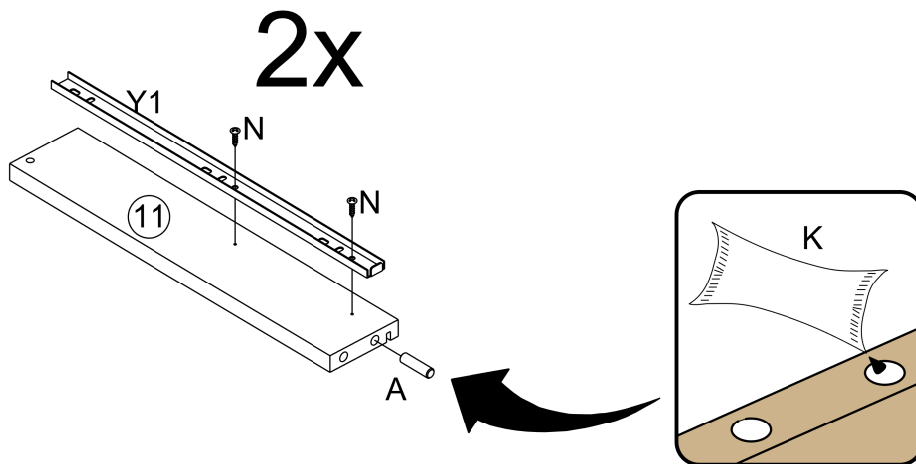
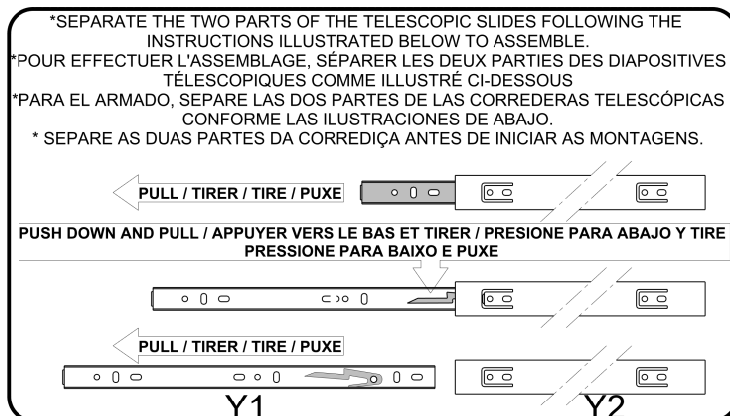
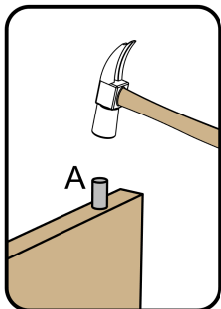

\*Note: add glue (K) in the holes before placing the wooden dowel.  
 \*Remarque: ajouter de la colle (K) dans les trous avant de placer la cheville en bois  
 \*Nota: agregue el pegamento (K) en los agujeros antes de colocar el taquete.  
 \*Nota: utilize a cola (K) antes da colocação das Cavilhas.

- 04 - Fix accessory (A) and telescopic slides (Y1) to part (10).**  
 Fixez l'accessoire (A) et les diapositives télescopiques (Y1) à la pièce (10).  
 Fijar accesorio (A) y correderas telescópicas (Y1) a pieza (10).  
 Fixe o acessório (A) e a corrediça telescópica (Y1) na peça (10).

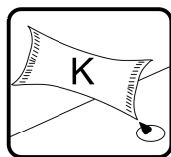

\*Note: add glue (K) in the holes before placing the wooden dowel.  
 \*Remarque: ajouter de la colle (K) dans les trous avant de placer la cheville en bois  
 \*Nota: agregue el pegamento (K) en los agujeros antes de colocar el taquete.  
 \*Nota: utilize a cola (K) antes da colocação das Cavilhas.

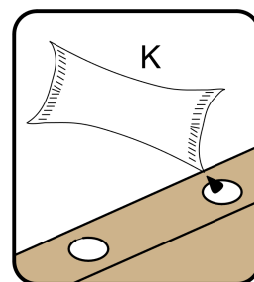
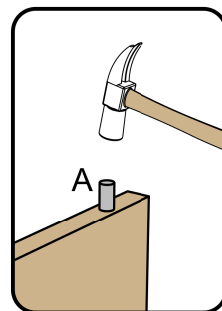
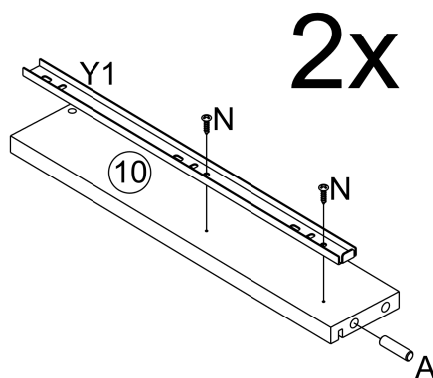

- 05 - Fix accessory (A) and telescopic slides (Y2) to part (03).**  
 Fixez l'accessoire (A) et les diapositives télescopiques (Y2) à la pièce (03).  
 Fijar accesorio (A) y correderas telescópicas (Y2) a pieza (03).  
 Fixe o acessório (A) e a corrediça telescópica (Y2) na peça (03).

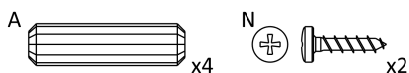
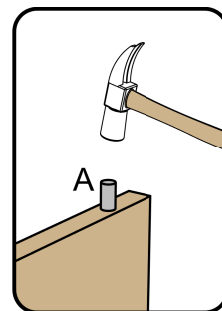
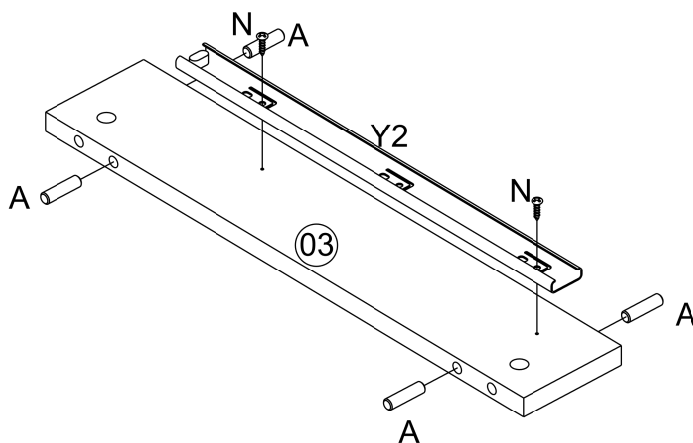

- 06** - Fix accessory (A) and telescopic slides (Y2) to part (04).  
 Fixez l'accessoire (A) et les diapositives télescopiques (Y2) à la pièce (04).  
 Fijar accesorio (A) y correderas telescópicas (Y2) a pieza (04).  
 Fixe o acessório (A) e a corrediça telescópica (Y2) na peça (03).

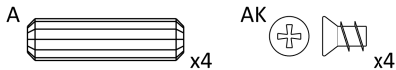
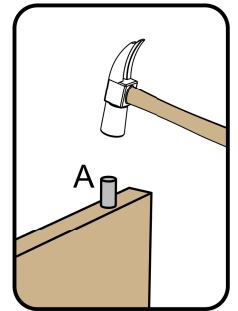
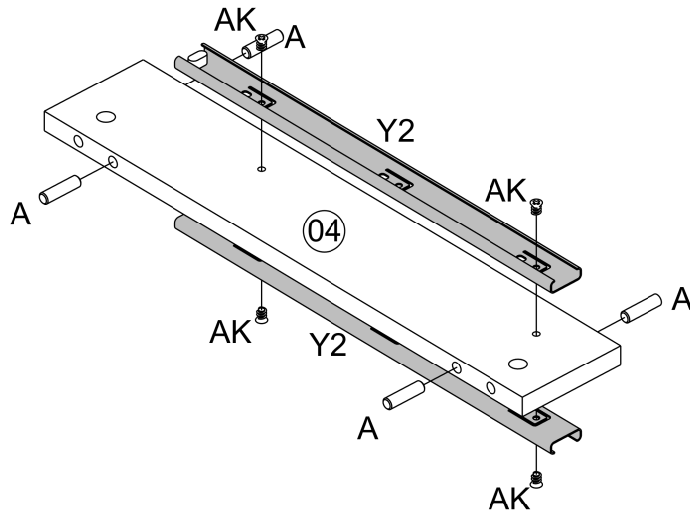

- 07** - Fix accessory (A) and telescopic slides (Y2) to part (05).  
 Fixez l'accessoire (A) et les diapositives télescopiques (Y2) à la pièce (05).  
 Fijar accesorio (A) y correderas telescópicas (Y2) a pieza (05).  
 Fixe o acessório (A) e a corrediça telescópica (Y2) na peça (05).

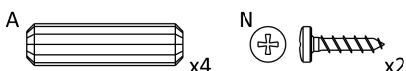
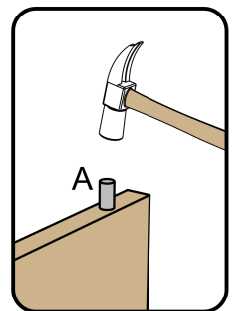
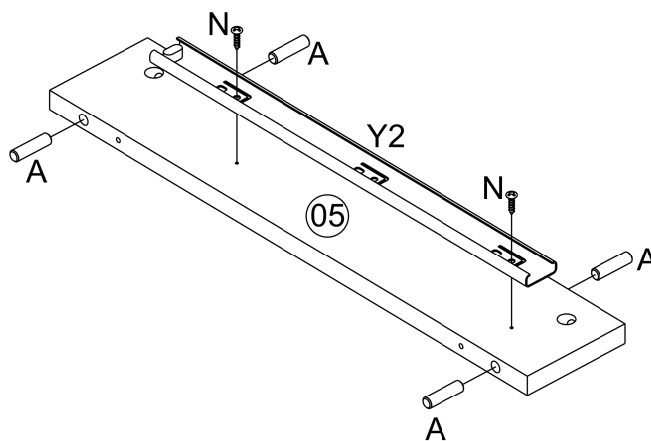

- 08** - Fix accessory (G) to part (07).  
Fixez l'accessoire (G) à la pièce (07).  
Fijar accesorio (G) a pieza (07).  
Fixe o acessório (G) na peça (07).

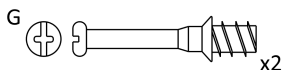
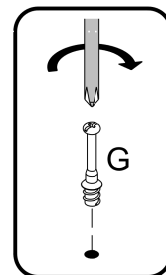
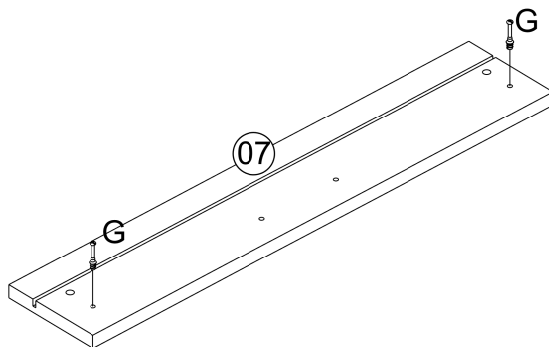

- 09** - Fix accessory (G) to part (08).  
Fixez l'accessoire (G) à la pièce (08).  
Fijar accesorio (G) a pieza (08).  
Fixe o acessório (G) na peça (08).

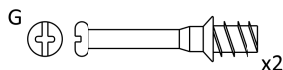
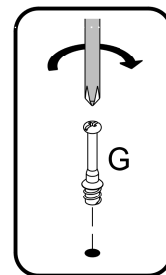
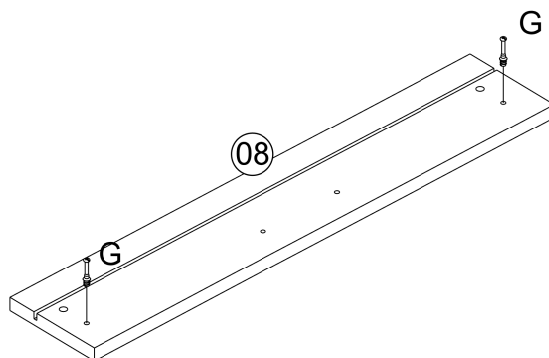



# ASSEMBLY

- 10 - Fix part (10), part (09) and part (11) with the accessory (C).  
 Fixez la pièce (10), la pièce (09) et la pièce (11) avec l'accessoire (C).  
 Fijar pieza (10), pieza (09) y pieza (11) con el accesorio (C).  
 Fixe a peça (10), a peça (09) e a peça (11) com o acessório (C).

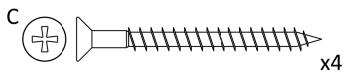
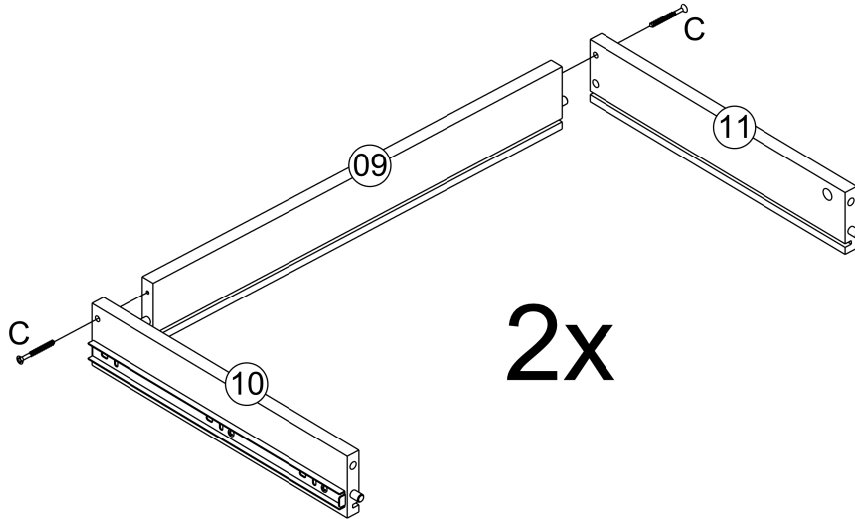

- 11 - Fix part (12) and part (07) with the accessory (H).  
 Fixez la pièce (12) et la pièce (07) avec le accessoire (H).  
 Fijar pieza (12) y pieza (07) con el accesorio (H).  
 Fixe a peça (12) e a peça (07) com o acessório (H).

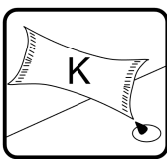

\*Note: add glue (K) in the holes before placing the wooden dowel.  
 \*Remarque: ajouter de la colle (K) dans les trous avant de placer la cheville en bois  
 \*Nota: agregue el pegamento (K) en los agujeros antes de colocar el taquete.  
 \*Nota: utilize a cola (K) antes da colocação das Cavilhas.

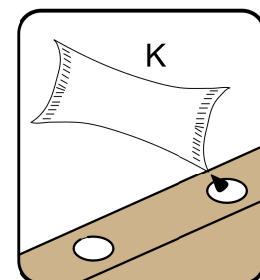
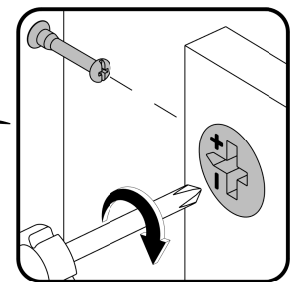
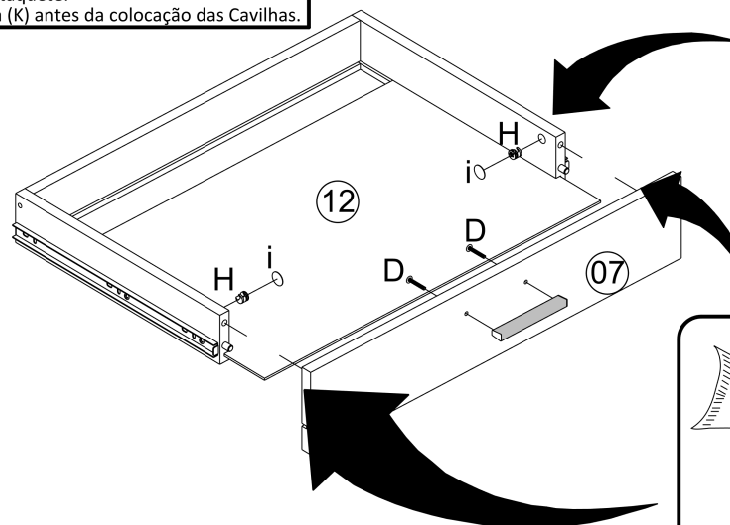

- 12 - Fix part (12) and part (08) with the accessory (H).**  
 Fixez la pièce (12) et la pièce (08) avec le accessoire (H).  
 Fijar pieza (12) y pieza (08) con el accesorio (H).  
 Fixe a peça (12) e a peça (08) com o acessório (H).

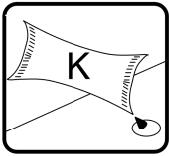

\*Note: add glue (K) in the holes before placing the wooden dowel.  
 \*Remarque: ajouter de la colle (K) dans les trous avant de placer la cheville en bois  
 \*Nota: agregue el pegamento (K) en los agujeros antes de colocar el taquete.  
 \*Nota: utilize a cola (K) antes da colocação das Cavilhas.

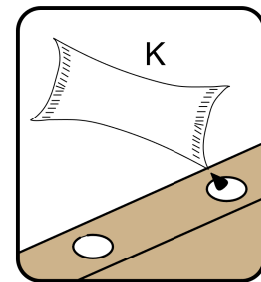
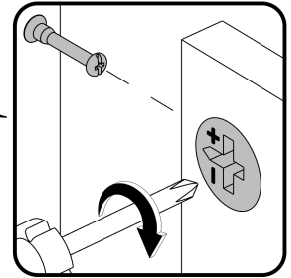
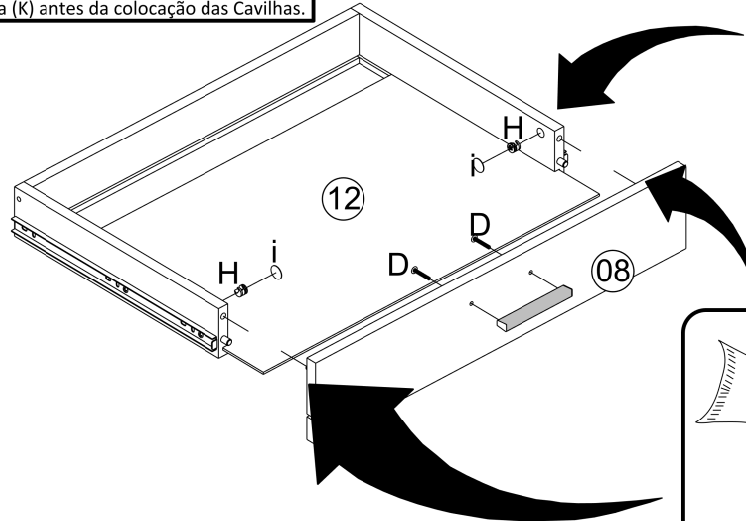

- 13 - Fix part (06) to foot with the accessory (AN).**  
 Fixez la pièce (06) au pied avec l'accessoire (AN).  
 Fijar pieza (06) a pie con el accesorio (AN).  
 Fixe a peça (06) e os pés com o acessório (AN).

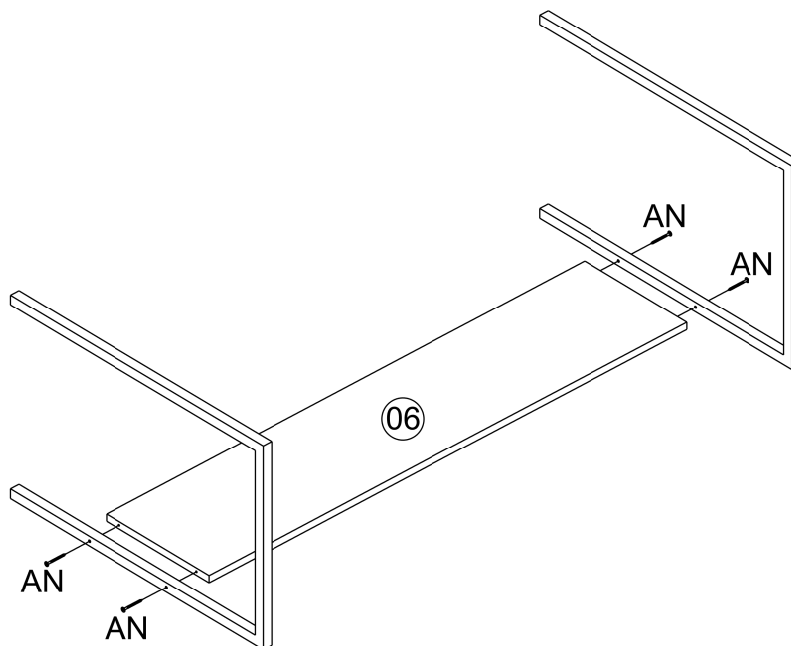

- 14 -** Fix part (02) to previous assembly with the accessory (AJ).  
Fixez la pièce (02) à l'assemblage précédent avec l'accessoire (AJ).  
Fijar pieza (02) a ensamble previo con el accesorio (AJ).  
Fixe a peça (02) na montagem anterior com o acessório (AJ).

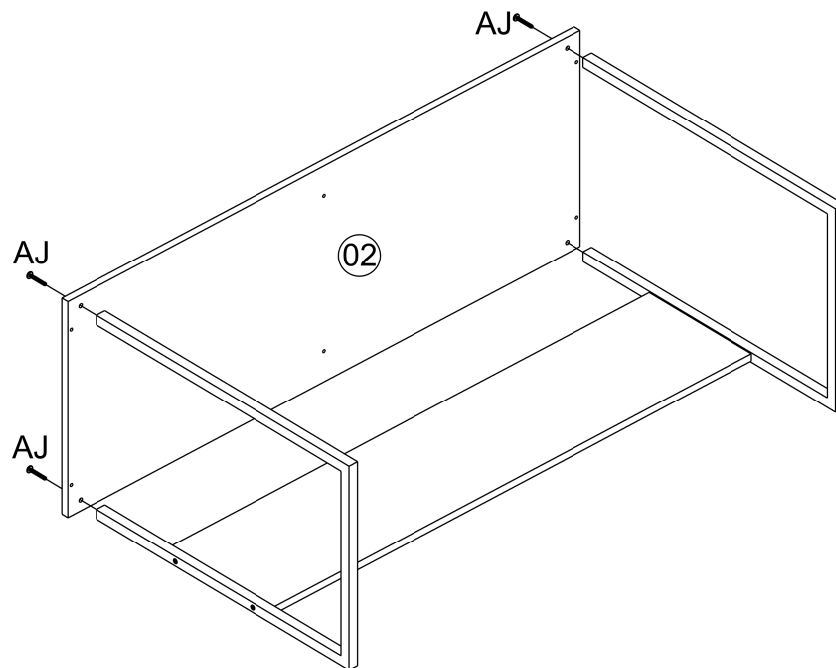

- 15 -** Fix part (03), part (04) and part (05) to previous assembly with the accessory (C).

Fixez la pièce (03), la pièce (04) et la pièce (05) à l'assemblage précédent avec l'accessoire (C).

Fijar pieza (03), pieza (04) y pieza (05) a ensamble previo con el accesorio (C).

Fixe a peça (03), a peça (04) e a peça (05) na montagem anterior com o acessório (C).

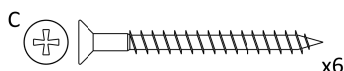
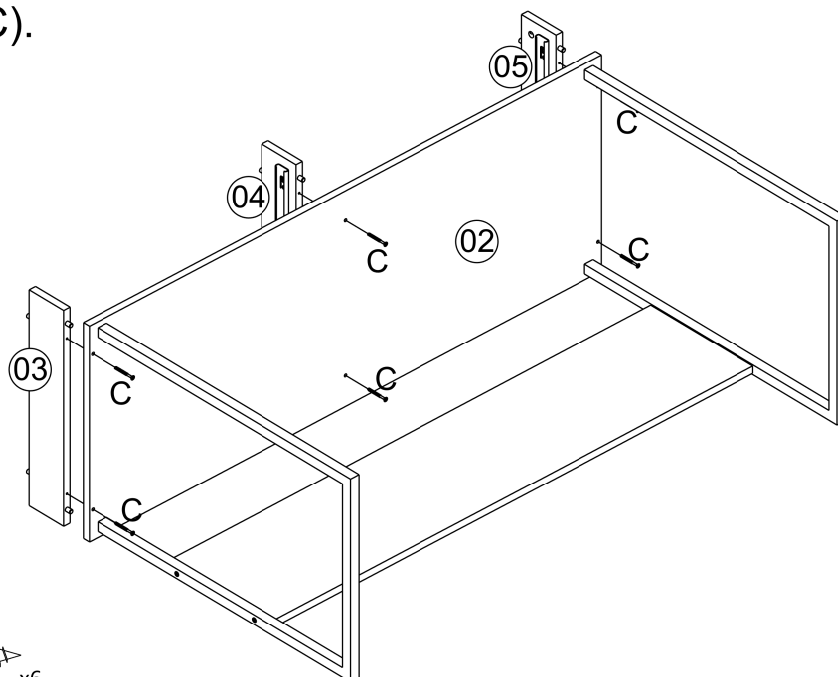

- 16 -** Fix part (01) to previous assembly with the accessory (H).  
 Fixez la pièce (01) à l'assemblage précédent avec l'accessoire (H).  
 Fijar pieza (01) a ensamble previo con el accesorio (H).  
 Fixe a peça (01) na montagem anterior com o acessório (H).

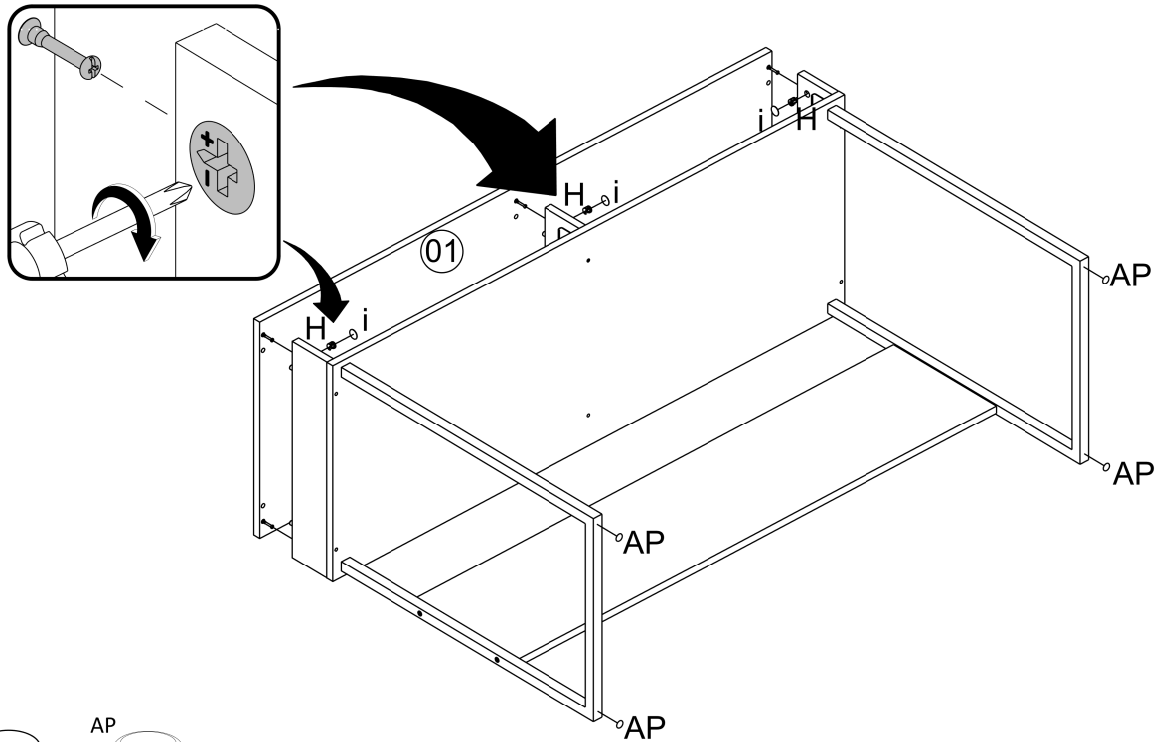

- 17 -** Fix part (13) to previous assembly with the accessory (J).  
 Fixez la pièce (13) à l'assemblage précédent avec l'accessoire (J).  
 Fijar pieza (13) a ensamble previo con el accesorio (J).  
 Fixe a peça (13) na montagem anterior com o acessório (J).

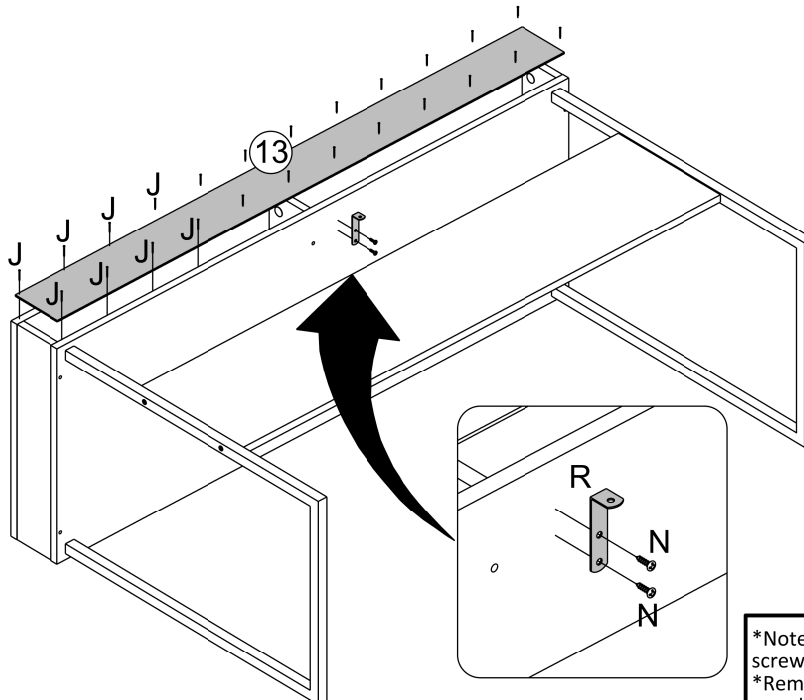

\*Note: the missing holes must be made with the screwdriver and the corresponding screw.  
 \*Remarque: Les trous manquants doivent être faits avec le tournevis et la vis correspondante.  
 \*Nota: los agujeros faltantes deben hacerse con el destornillador y el tornillo correspondiente.  
 \*Nota: As furações faltantes devem ser feitas com a chave e o parafuso correspondente.

- 18 -** Fix previously assemblies (steps 11, 12 and 17).  
Fixez assemblages précédents (étapes 11, 12 et 17).  
Fijar ensambles previos (pasos 11, 12 y 17).  
Junte as montagens anteriores (passos 11, 12 e 17).

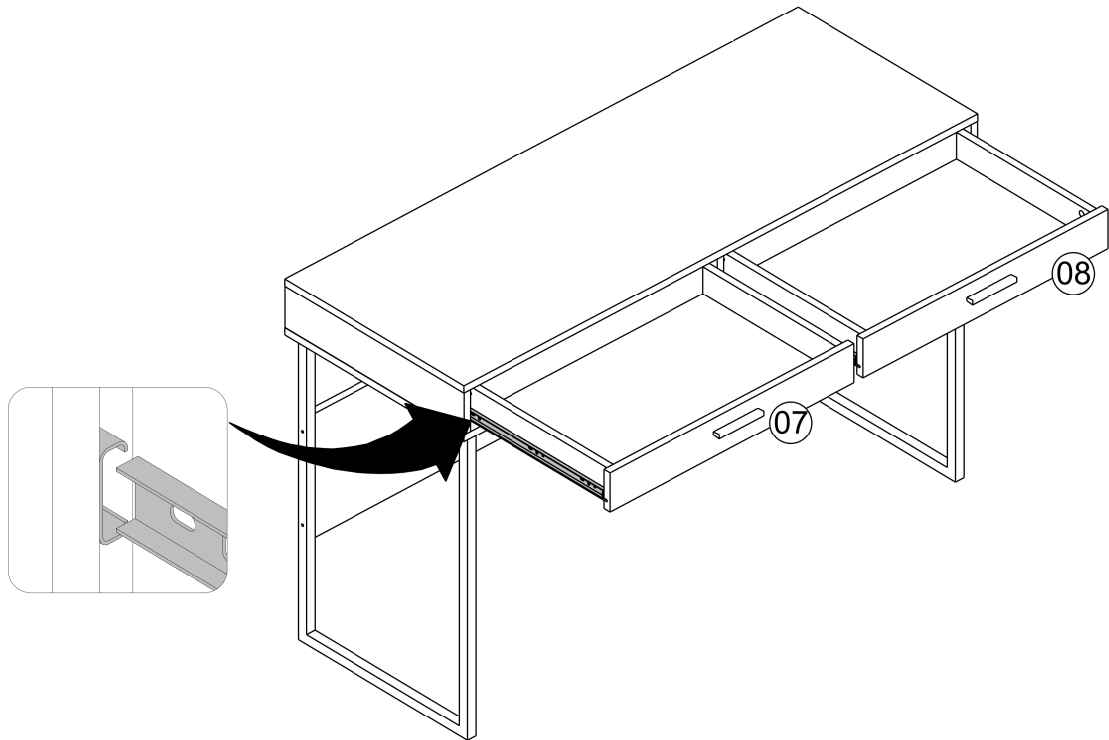

- 19 -** Fix furniture to the wall.  
Fixez le meuble au mur.  
Fijar mueble a la pared.  
Fixe o móvel na parede.

