

YOU WILL NEED

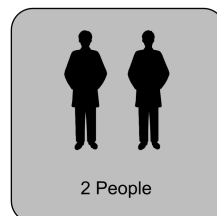

Tools not included

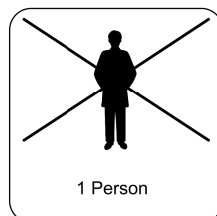
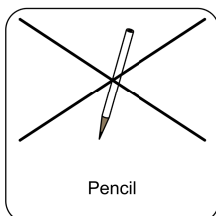
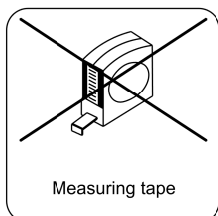
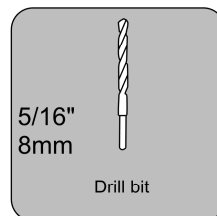
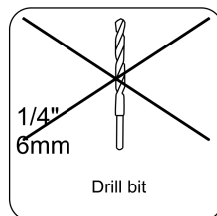
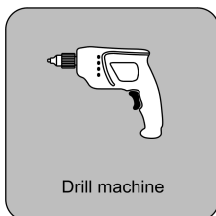
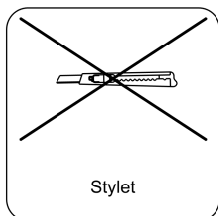
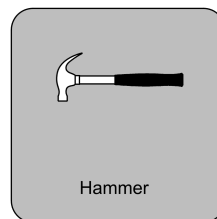
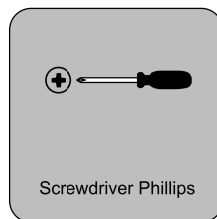
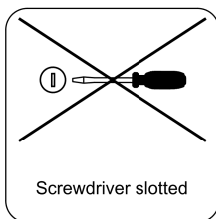
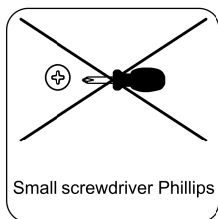
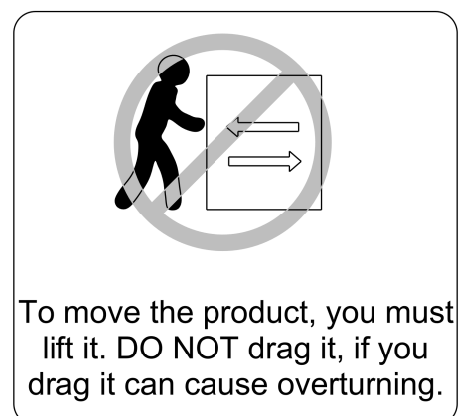
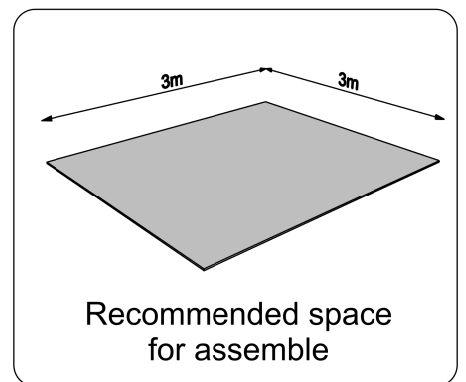

PARTS IDENTIFICATION

01	Top Base Base Supérieure Base Superior Base Superior	Qty./Qtd. 01	13	Right Top Side Côté Supérieur Droite Lateral Superior Derecho Lateral Superior Direita	Qty./Qtd. 01	25	Top Backboard Panneau Supérieure Fondo Superior Costa Superior	Qty./Qtd. 01
02	Shelf Étagère Repisa Prateleira	Qty./Qtd. 02	14	Left Bottom Side Côté Inférieur Gauche Lateral Inferior Izquierdo Lateral Inferior Esquerda	Qty./Qtd. 01	26	Backboard Panneau Fondo Trasero Costa	Qty./Qtd. 01
03	Center Shelf Étagère Centrale Repisa Central Prateleira Central	Qty./Qtd. 01	15	Division Division División Divisória	Qty./Qtd. 01	27	Backboard of drawer Arrière du Tiroir Fondo de cajón Fundo de Gaveta	Qty./Qtd. 02
04	Top Plan de Travail Tapa Tampo	Qty./Qtd. 01	16	Right Bottom Side Côté Inférieur Droite Lateral Inferior Derecho Lateral Inferior Direita	Qty./Qtd. 01			
05	Bottom Base Base Inférieure Base Inferior Base Inferior	Qty./Qtd. 01	17	Bigger Drawer Front Plus Grand Tiroir Avant Frente Mayor Del Cajón Frente de Gaveta Maior	Qty./Qtd. 01			
06	Tray Plateau Traviesa Travessa	Qty./Qtd. 01	18	Drawer Front Avant de Tiroir Frente del Cajón Frente de Gaveta	Qty./Qtd. 02			
07	Front Tray Plateau Avant Traviesa Frontal Travessa Frontal	Qty./Qtd. 01	19	Bigger Rear of Drawer Plus Grand Arrière du Tiroir Posterior de Cajón Mayor Traseiro de Gaveta Maior	Qty./Qtd. 01			
08	Rear Tray Plateau Arrière Traviesa Posterior Travessa Traseira	Qty./Qtd. 01	20	Rear of Drawer Arrière du Tiroir Posterior de Cajón Traseiro de Gaveta	Qty./Qtd. 02			
09	Mirror Panel Panneau Miroir Panel Espejo Painel Espelho	Qty./Qtd. 01	21	Left Side of Drawer Côté Gauche du Tiroir Lateral Izquierdo de Cajón Lateral Esquerda de Gaveta	Qty./Qtd. 03			
10	Panel Support Support de Panneau Panel Soporte Suporte Painel	Qty./Qtd. 01	22	Right Side of Drawer Côté Droite du Tiroir Lateral Derecho de Cajón Lateral Direita de Gaveta	Qty./Qtd. 03			
11	Panel Panneau Panel Painel	Qty./Qtd. 01	23	Bigger Backboard of drawer Plus Grand Panneau du Tiroir Fondo Mayor de cajón Fundo de Gaveta Maior	Qty./Qtd. 01			
12	Left Top Side Côté Supérieur Gauche Lateral Superior Izquierdo Lateral Esquerda Superior	Qty./Qtd. 01	24	Door Porte Puerta Porta	Qty./Qtd. 01			

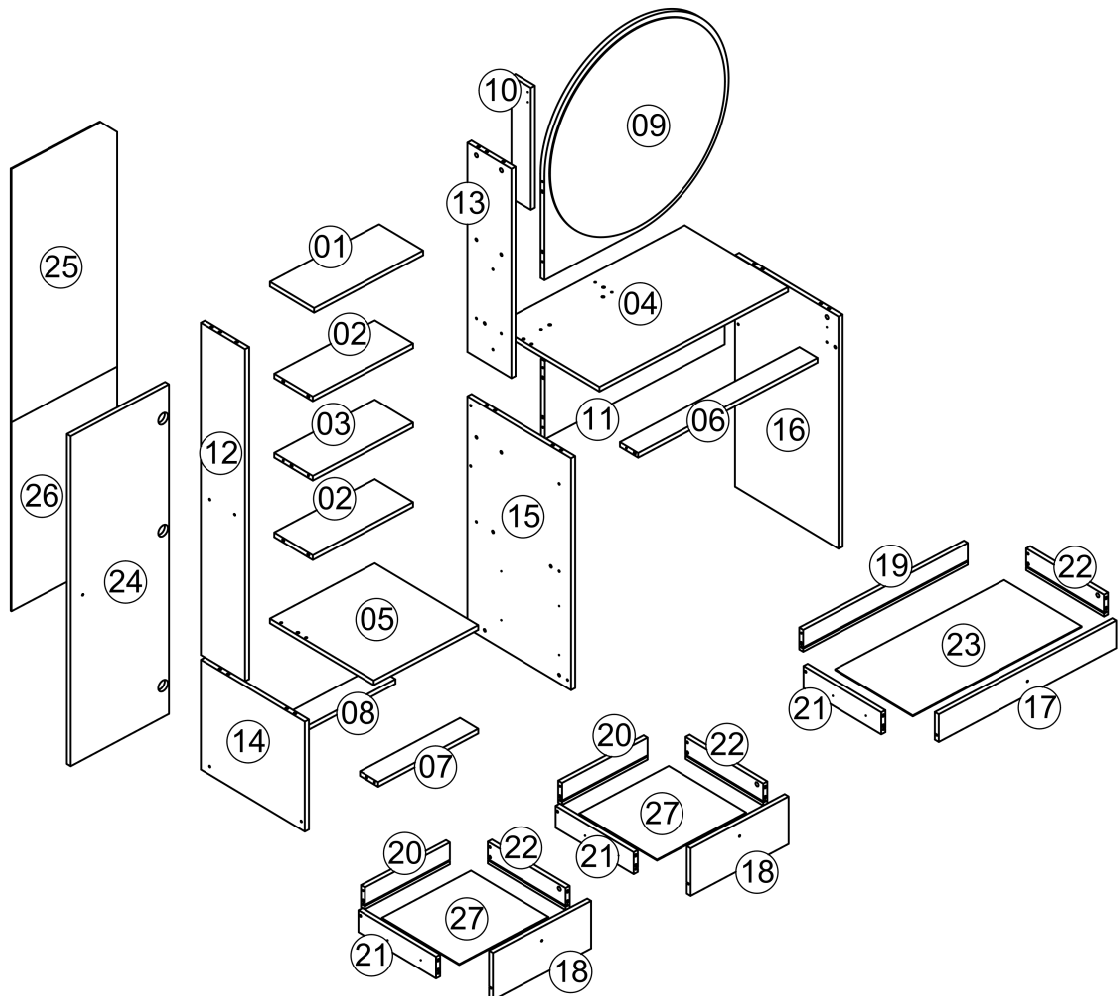

GENERAL DIMENSIONS

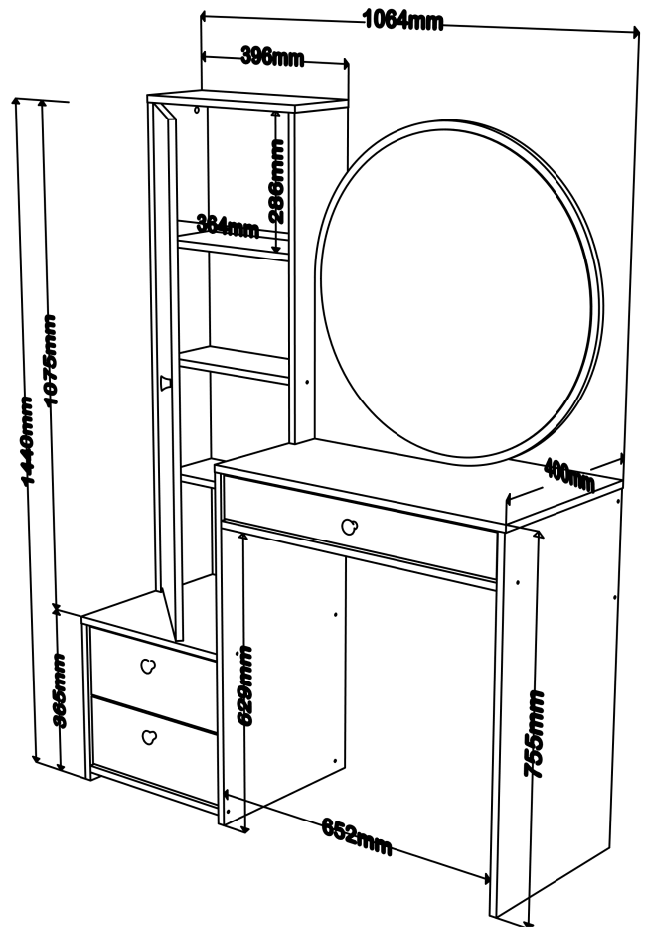
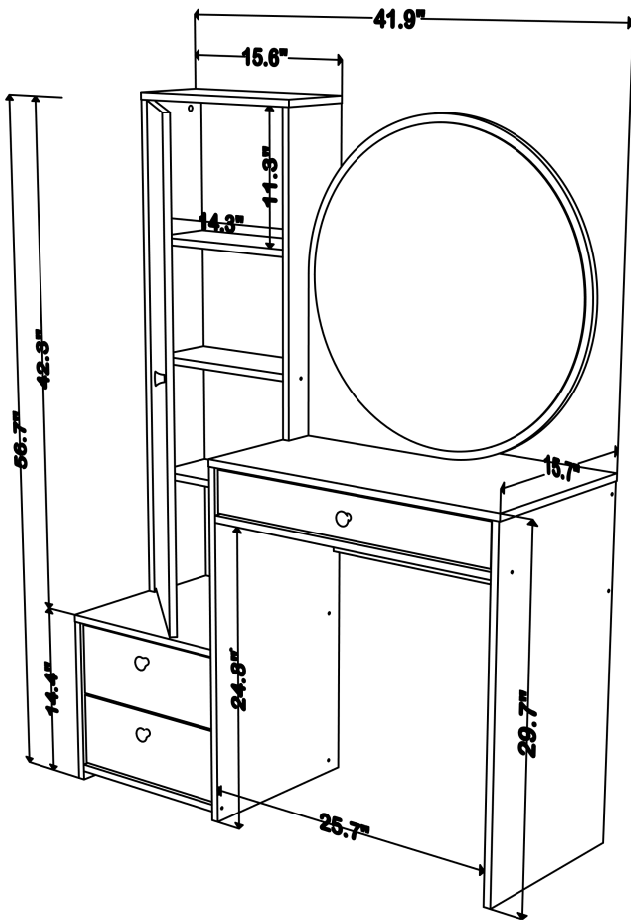





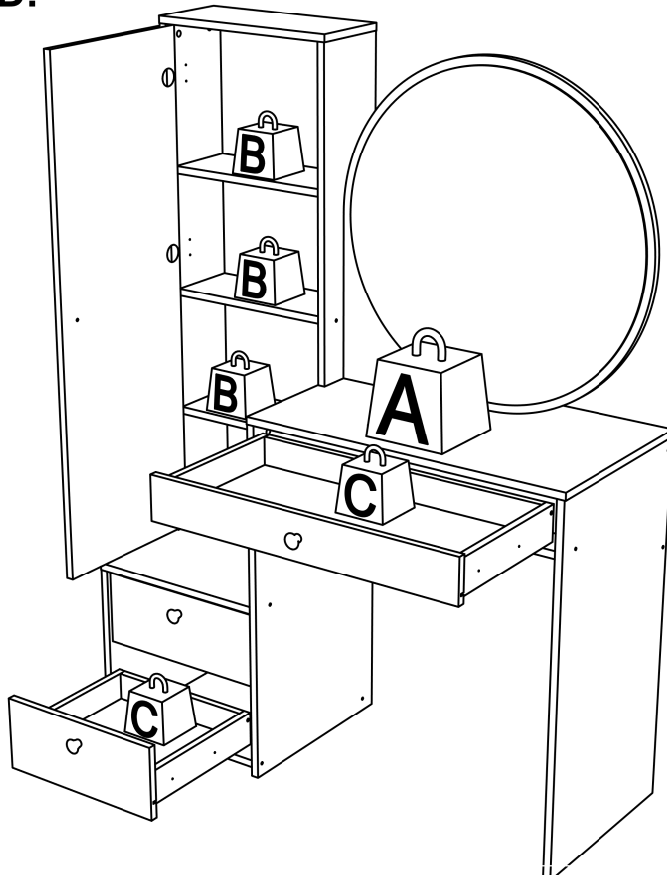



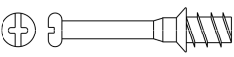

MAXIMUM RECOMMENDED WEIGHT BEING THIS EVENLY DISTRIBUTED.

	LB	KG
A	55	25
B	11	5
C	4,4	2

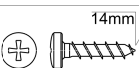
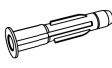

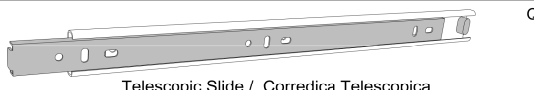
ACCESSORIES IDENTIFICATION

A		Qty./Qtd. 45	
Wooden dowel / Chevilles en bois / Taquete / Caviha			
AA		Qty./Qtd. 3	
Metal hinge super high / Charnière super haute / Bisagra alta / Dobradiça Alta			
AD		Qty./Qtd. 2	
Allen key / Clé Allen / Liave allen / Chave Allen			
AM		Qty./Qtd. 2	
Wooden dowel / Chevilles en bois / Taquete / Caviha			
B		Qty./Qtd. 21	
Structural screw / Vis à tête structurelle / Tornillo estructural / Parafuso Estrutural			
C		Qty./Qtd. 10	
Structural screw / Vis à tête structurelle / Tornillo estructural / Parafuso Estrutural			
D		Qty./Qtd. 4	
Flanged head screw / Vis à tête bride / Tornillo de cabeza flangeada / Parafuso Flangeado			
F		Qty./Qtd. 21	
Structural screw cover/Cache-vis structurel/Tapa tornillo estructural/ Tampa estrutural			
G		Qty./Qtd. 16	
Simple minifix screw / Vis minifix simple / Tornillo minifix simple / Haste Minifix Simples			
H		Qty./Qtd. 16	
Drum lock / Verrouillage du tambour / Tambor minifix / Tambor de Minifix			
i		Qty./Qtd. 16	
Bore patch adhesive / Adhésif de correction d'alésage / Tapones adhesivo/ Adesivo Tapa Furo			
J		Qty./Qtd. 44	
Nail / Ongle / Clavo / Prego			
K		Qty./Qtd. 1	
Glue / Colle / Pegamento / Bisnaga de Cola			
M		Qty./Qtd. 1	
Metalic angle plates / Support métallique / Suporte de metal / Cantoneira de Metal			
N		Qty./Qtd. 42	
Pan head screw / Vis à tête bombée / Tornillo de pan / Parafuso Panela			
R		Qty./Qtd. 1	
Metalic bracket / Support métallique / Soporte de metal / Suporte de Metal			
S		Qty./Qtd. 1	
Bushing / Douille expansive / Tapón / Bucha Plástica			
T		Qty./Qtd. 1	
Flanged head screw / Vis à tête bride / Tornillo de cabeza flangeada/ Parafuso flangeado			
V		Qty./Qtd. 6	
Small plastic foot / Chaussure de glisse / Pie plástico / Sapata Plástica			
Y	 Telescopic Slide / Corrediça Telescopica Corredera Telescópica / Corrediça Telescópica	Qty./Qtd. 3	
			
Z		Qty./Qtd. 3	
Metal claw / Pince de métal / Garra metal / Garra de Metal			

Separating the accessories before starting the assembly will make it easier. In case of doubts about the size of the screws and wooden dowels, use the ruler at the end of this page.

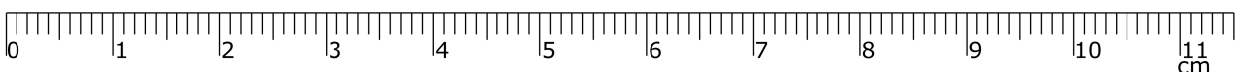

PRE-ASSEMBLY

01 -Fix accessory (A) and accessory (M) to part (09).

Fixez l'accessoire (A) et l'accessoire (M) à la pièce (09).

Fijar accesorio (A) y accesorio (M) a pieza (09).

Fixe o acessório (A) e o acessório (M) na peça (09).

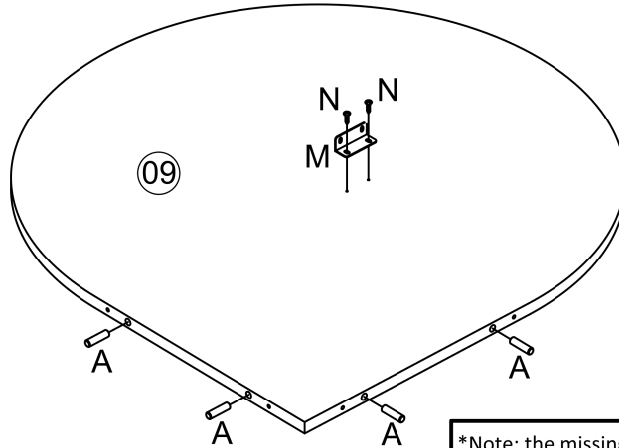
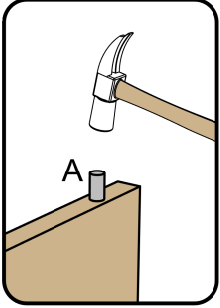

*Note: the missing holes must be made with the screwdriver and the corresponding screw.
*Remarque: Les trous manquants doivent être faits avec le tournevis et la vis correspondante.
*Nota: los agujeros faltantes deben hacerse con el destornillador y el tornillo correspondiente.
*Nota: As furações faltantes devem ser feitas com a chave e o parafuso correspondente.

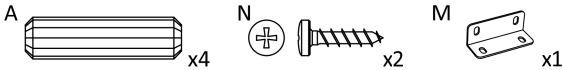

02 -Fix accessory (A) to part (07).

Fixez l'accessoire (A) à la pièce (07).

Fijar accesorio (A) a pieza (07).

Fixe o acessório (A) na peça (07).

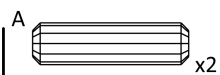
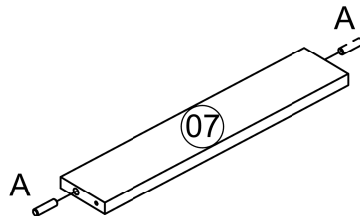
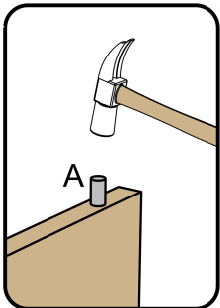

- 03** -Fix accessory (A) to part (02).
Fixez l'accessoire (A) à la pièce (02).
Fijar accesorio (A) a pieza (02).
Fixe o acessório (A) na peça (02).

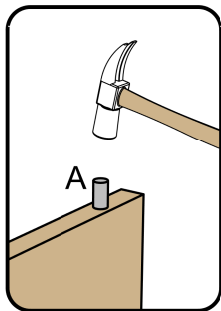

2x

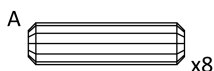
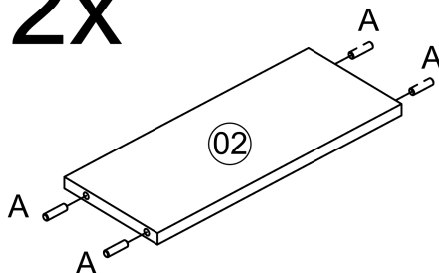

- 04** -Fix accessory (A) to part (03).
Fixez l'accessoire (A) à la pièce (03).
Fijar accesorio (A) a pieza (03).
Fixe o acessório (A) na peça (03).

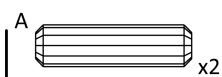
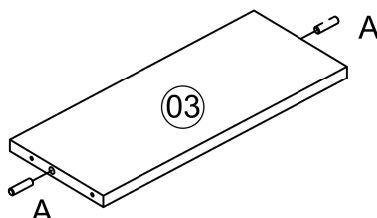
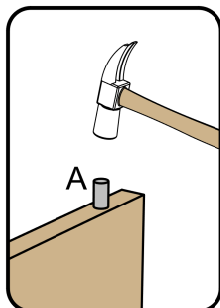

- 05** -Fix accessory (A) to part (11).
 Fixez l'accessoire (A) à la pièce (11).
 Fijar accesorio (A) a pieza (11).
 Fixe o acessório (A) na peça (11).

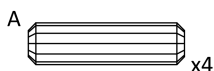
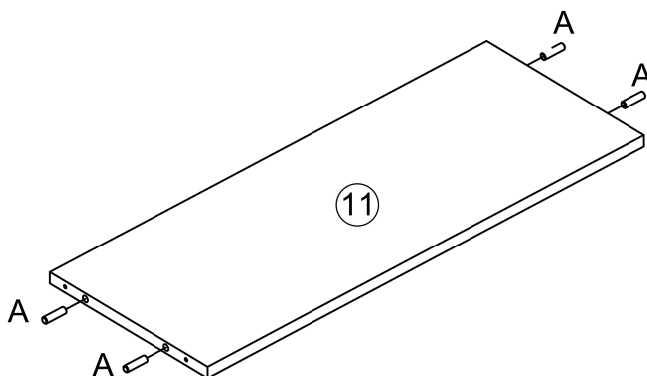
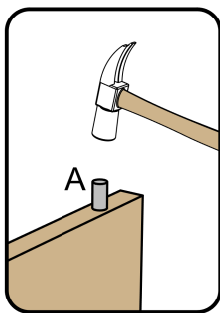

- 06** -Fix accessory (A) and accessory (G) to part (05).
 Fixez l'accessoire (A) et l'accessoire (G) à la pièce (05).
 Fijar accesorio (A) y accesorio (G) a pieza (05).
 Fixe o acessório (A) e o acessório (G) na peça (05).

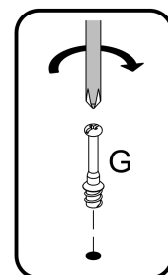
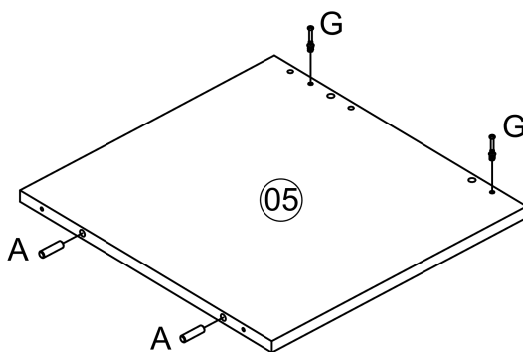
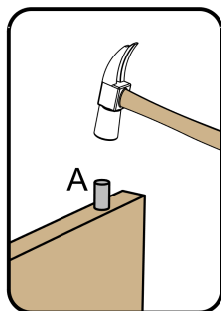

- 07** -Fix accessory (A) to part (13).
Fixez l'accessoire (A) à la pièce (13).
Fijar accesorio (A) a pieza (13).
Fixe o acessório (A) na peça (13).

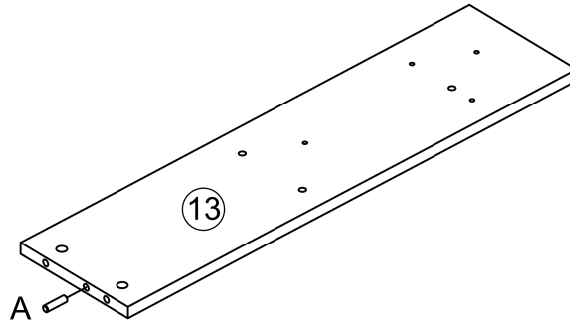
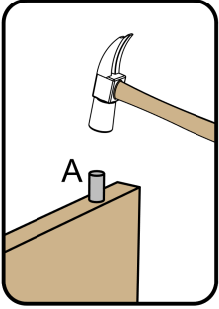

- 08** -Fix accessory (G) to part (01).
Fixez l'accessoire (G) à la pièce (01).
Fijar accesorio (G) a pieza (01).
Fixe o acessório (G) na peça (01).

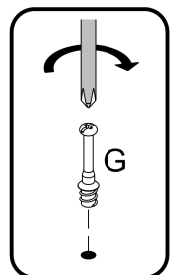
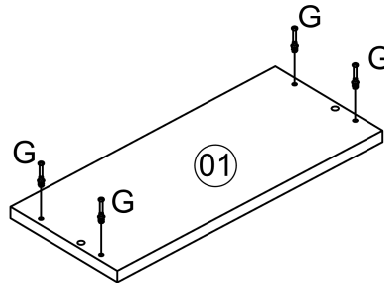

- 09** -Fix accessory (G) to part (04).
Fixez l'accessoire (G) à la pièce (04).
Fijar accesorio (G) a pieza (04).
Fixe o acessório (G) na peça (04).

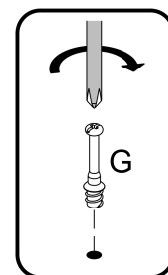
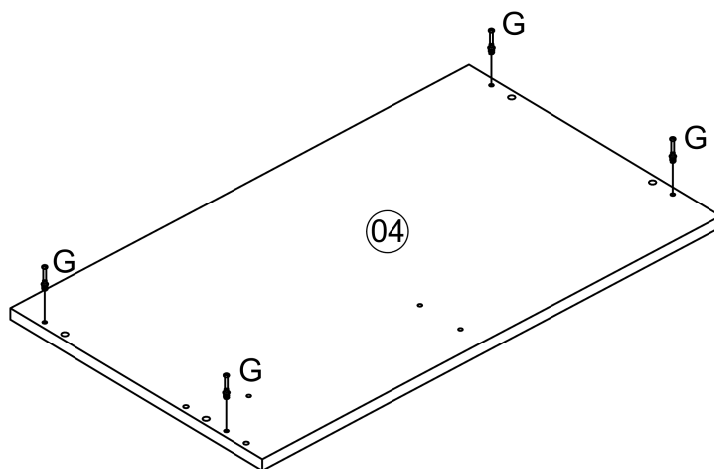

- 10** -Fix accessory (A) to part (06).
Fixez l'accessoire (A) à la pièce (06).
Fijar accesorio (A) a pieza (06).
Fixe o acessório (A) na peça (06).

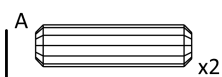
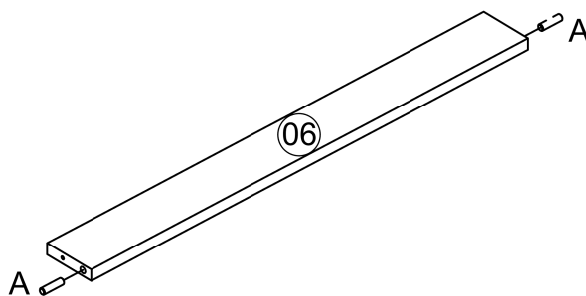
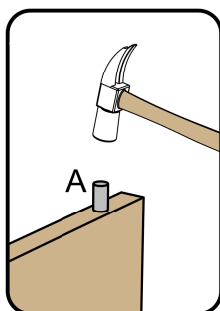

- 11** -Fix accessory (A) to part (10).
Fixez l'accessoire (A) à la pièce (10).
Fijar accesorio (A) a pieza (10).
Fixe o acessório (A) na peça (10).

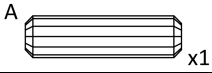
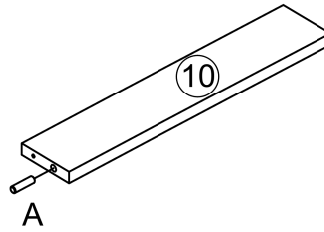
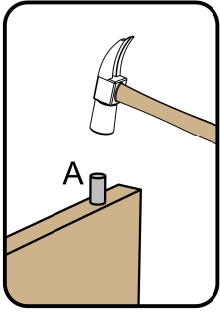

- 12** -Fix accessory (A) to part (08).
Fixez l'accessoire (A) à la pièce (08).
Fijar accesorio (A) a pieza (08).
Fixe o acessório (A) na peça (08).

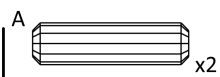
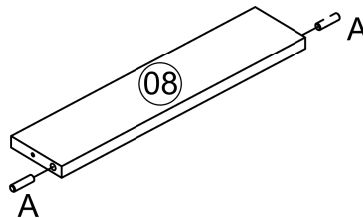
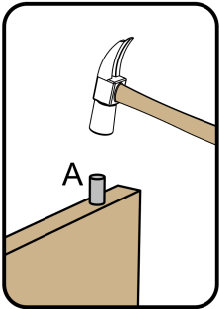

- 13** -Fix accessory (A), accessory (AM) and telescopic slides (Y2) to part (15).
 Fixez l'accessoire (A), l'accessoire (AM) et les diapositives télescopiques (Y2) à la pièce (15).
 Fijar accesorio (A), accesorio (AM) y correderas telescópicas (Y2) a pieza (15).
 Fixe o acessório (A), o acessório (AM) e a corredeira telescópica (Y2) na peça (15).

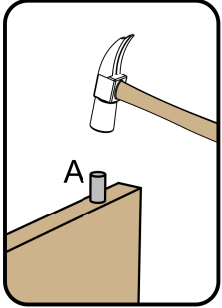

*SEPARATE THE TWO PARTS OF THE TELESCOPIC SLIDES FOLLOWING THE INSTRUCTIONS ILLUSTRATED BELOW TO ASSEMBLE.
 *POUR EFFECTUER L'ASSEMBLAGE, SÉPARER LES DEUX PARTIES DES DIAPOSITIVES TÉLESCOPIQUES COMME ILLUSTRÉ CI-DESSOUS
 *PARA EL ARMADO, SEPARA LAS DOS PARTES DE LAS CORREDERAS TELESCÓPICAS CONFORME LAS ILUSTRACIONES DE ABAJO.
 * SEPARA AS DUAS PARTES DA CORREDIÇA ANTES DE INICIAR AS MONTAGENS.

PULL / TIRER / TIRE / PUXE

PUSH DOWN AND PULL / APPUYER VERS LE BAS ET TIRER / PRESIONE PARA ABAJO Y TIRE / PRESSIÃO PARA BAIXO E PUXE

PULL / TIRER / TIRE / PUXE

Y1 Y2

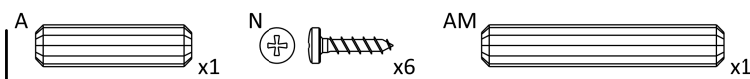
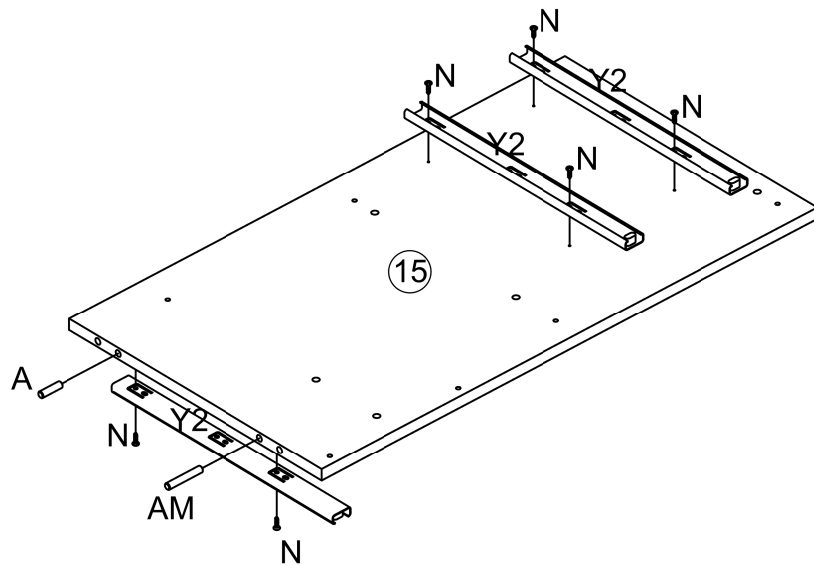

- 14** -Fix accessory (A), accessory (AM) and telescopic slides (Y2) to part (14).
 Fixez l'accessoire (A), l'accessoire (AM) et les diapositives télescopiques (Y2) à la pièce (14).
 Fijar accesorio (A), accesorio (AM) y correderas telescópicas (Y2) a pieza (14).
 Fixe o acessório (A), o acessório (AM) e a corrediça telescópica (Y2) na peça (14).

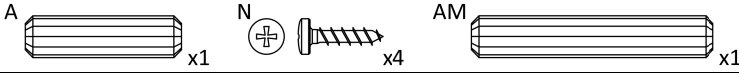
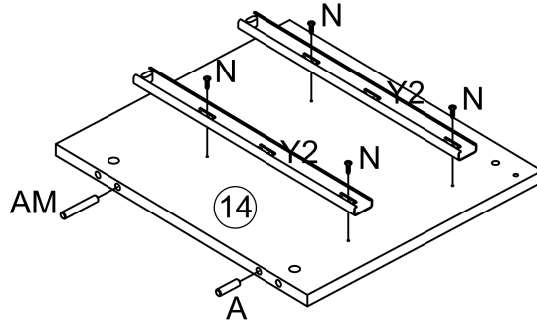
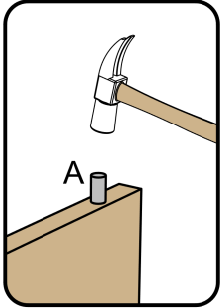

- 15** -Fix accessory (A) to part (12).
 Fixez l'accessoire (A) à la pièce (12).
 Fijar accesorio (A) a pieza (12).
 Fixe o acessório (A) na peça (12).

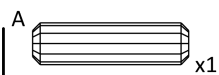
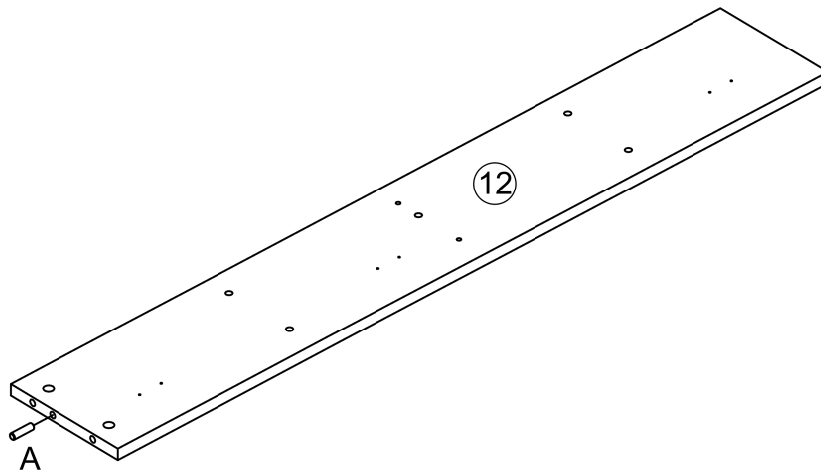
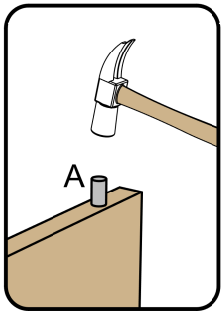

16 -Fix accessory (A) and telescopic slides (Y2) to part (16).
 Fixez l'accessoire (A) et les diapositives télescopiques (Y2) à la pièce (16).
 Fijar accesorio (A) y correderas telescópicas (Y2) a pieza (16).
 Fixe o acessório (A) e a corredeira telescópica (Y2) na peça (16).

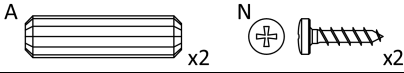
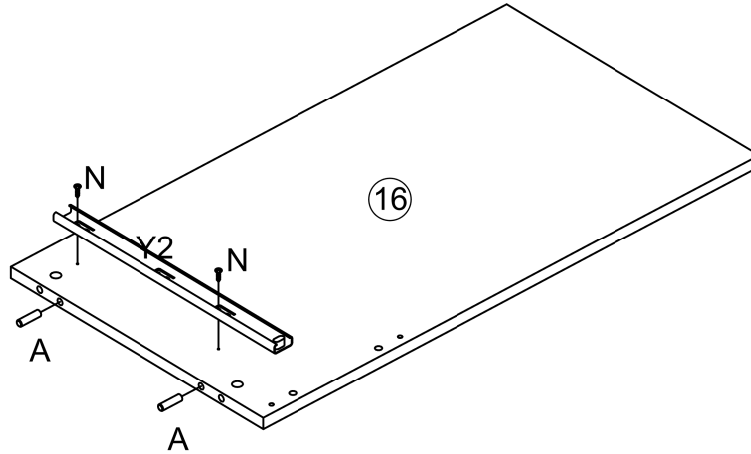
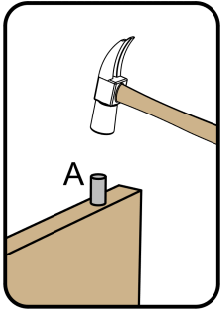

17 -Fix accessory (AA) to part (24).
 Fixez l'accessoire (AA) à la pièce (24).
 Fijar accesorio (AA) a pieza (24).
 Fixe o acessório (AA) na peça (24).

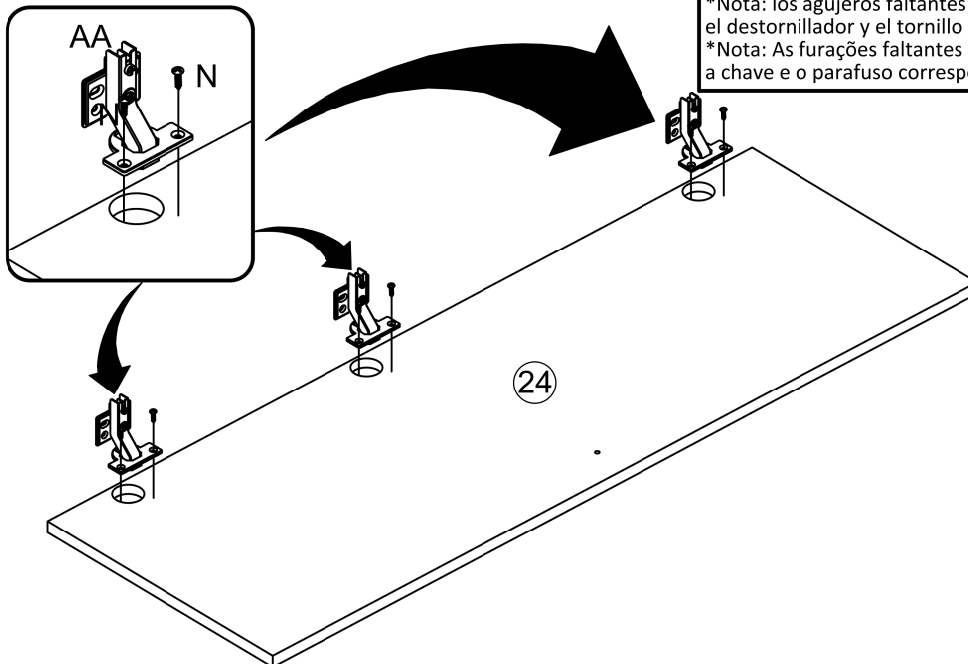

*Note: the missing holes must be made with the screwdriver and the corresponding screw.
 *Remarque: Les trous manquants doivent être faits avec le tournevis et la vis correspondante.
 *Nota: los agujeros faltantes deben hacerse con el destornillador y el tornillo correspondiente.
 *Nota: As furações faltantes devem ser feitas com a chave e o parafuso correspondente.

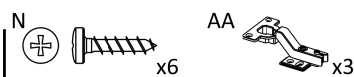

- 18** -Fix accessory (G) to part (17).
 Fixez l'accessoire (G) à la pièce (17).
 Fijar accesorio (G) a pieza (17).
 Fixe o acessório (G) na peça (17).

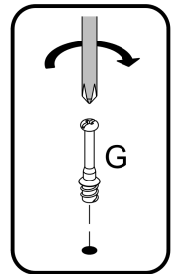
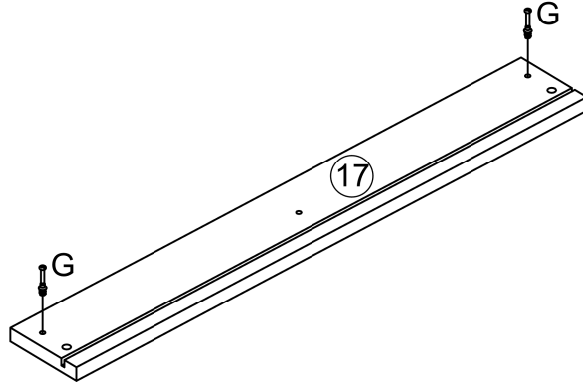

- 19** -Fix accessory (G) to part (18).
 Fixez l'accessoire (G) à la pièce (18).
 Fijar accesorio (G) a pieza (18).
 Fixe o acessório (G) na peça (18).

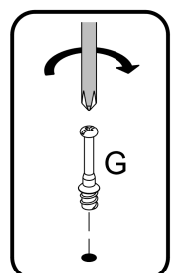
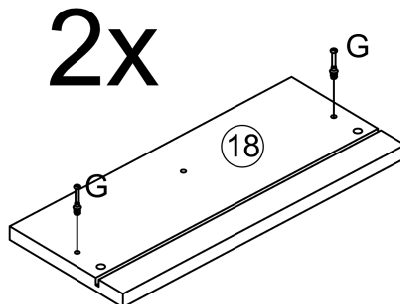

- 20** -Fix accessory (A) to part (20).
Fixez l'accessoire (A) à la pièce (20).
Fijar accesorio (A) a pieza (20).
Fixe o acessório (A) na peça (20).

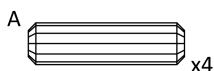
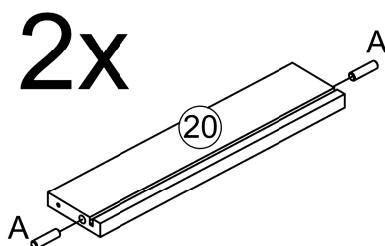
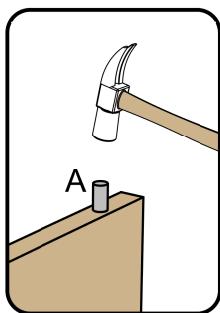

- 21** -Fix accessory (A) to part (19).
Fixez l'accessoire (A) à la pièce (19).
Fijar accesorio (A) a pieza (19).
Fixe o acessório (A) na peça (19).

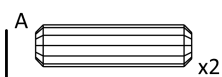
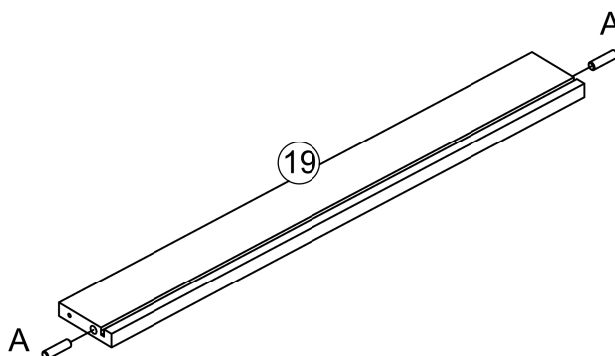
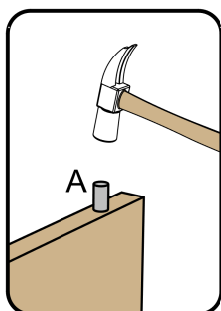

- 22** -Fix accessory (A) and telescopic slides (Y1) to part (21).
 Fixez l'accessoire (A) et les diapositives télescopiques (Y1) à la pièce (21).
 Fijar accesorio (A) y correderas telescópicas (Y1) a pieza (21).
 Fixe o acessório (A) e a corrediça telescópica (Y1) na peça (21).

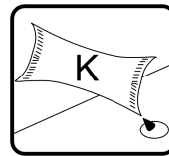
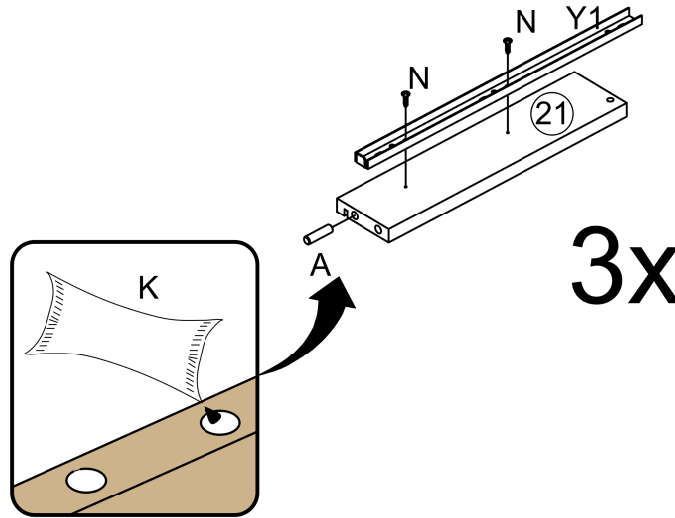
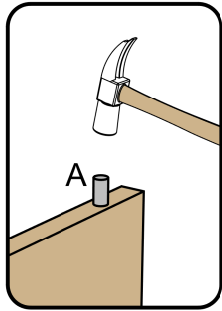

*Note: add glue (K) in the holes before placing the wooden dowel.
 *Remarque: ajouter de la colle (K) dans les trous avant de placer la cheville en bois
 *Nota: agregue el pegamento (K) en los agujeros antes de colocar el taquete.
 *Nota: utilize a cola (K) antes da colocação das Cavilhas.



- 23** -Fix accessory (A) and telescopic slides (Y1) to part (22).
 Fixez l'accessoire (A) et les diapositives télescopiques (Y1) à la pièce (22).
 Fijar accesorio (A) y correderas telescópicas (Y1) a pieza (22).
 Fixe o acessório (A) e a corrediça telescópica (Y1) na peça (22).

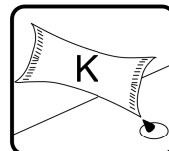
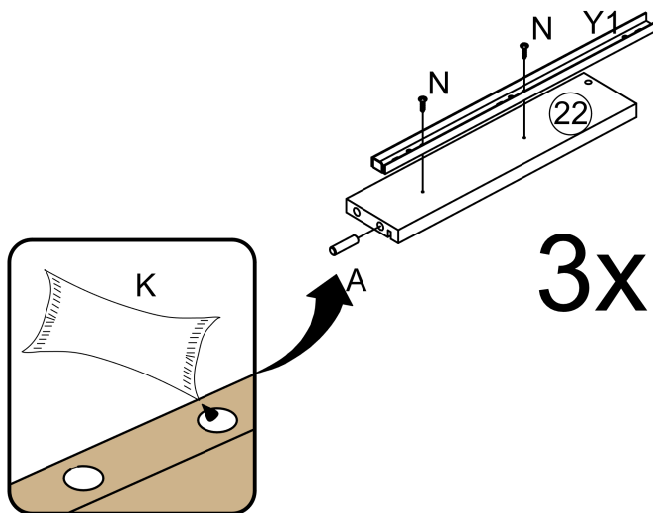
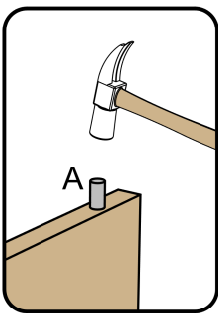

*Note: add glue (K) in the holes before placing the wooden dowel.
 *Remarque: ajouter de la colle (K) dans les trous avant de placer la cheville en bois
 *Nota: agregue el pegamento (K) en los agujeros antes de colocar el taquete.
 *Nota: utilize a cola (K) antes da colocação das Cavilhas.

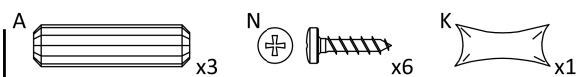

ASSEMBLY

- 24 -Fix part (15), part (06), part (11) and part (16) with the accessory (B).
Fixez la pièce (15), la pièce (06), la pièce (11) et la pièce (16) avec le accessoire (B).
Fijar pieza (15), pieza (06), pieza (11) y pieza (16) con el accesorio (B).
Fixe a peça (15), a peça (06), a peça (11) e a peça (16) com o acessório (B).

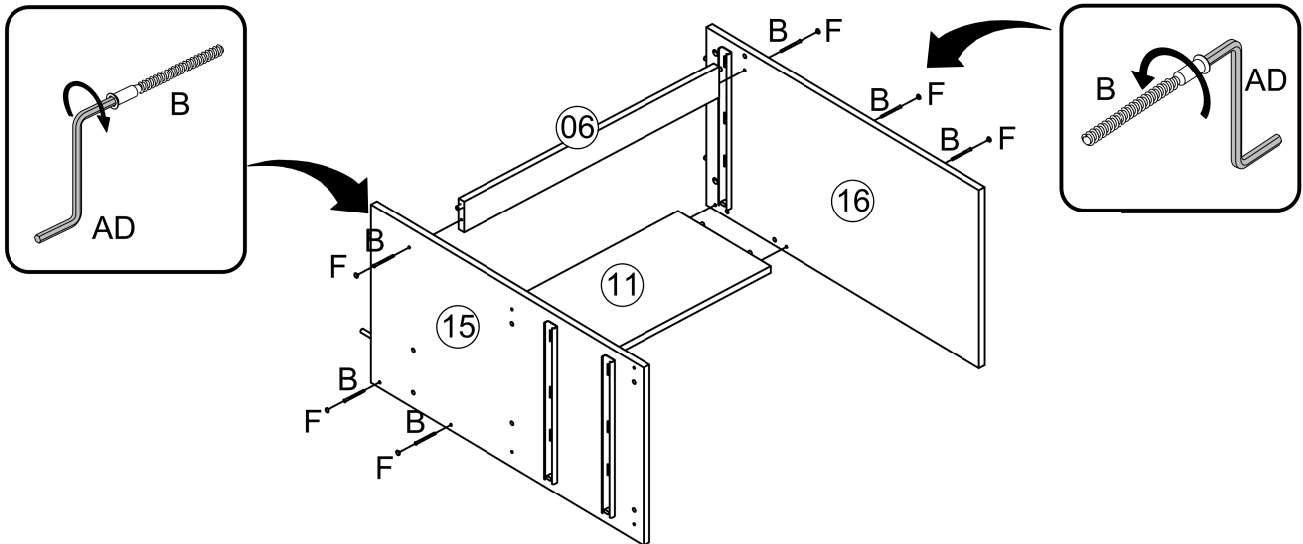

- 25 -Fix part (03) and part (13) with the accessory (B).
Fixez la pièce (03) et la pièce (13) avec le accessoire (B).
Fijar pieza (03) y pieza (13) con el accesorio (B).
Fixe a peça (03) e a peça (13) com o acessório (B).

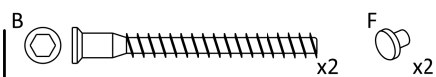
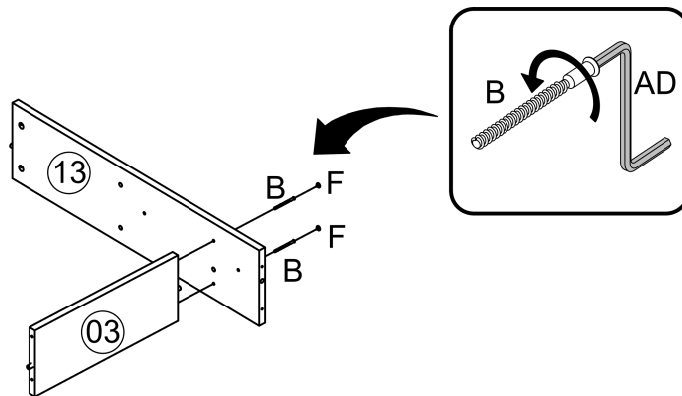

- 26** -Fix part (09) to previous assembly with the accessory (B).
 Fixez la pièce (09) à l'assemblage précédent avec l'accessoire (B).
 Fijar pieza (09) a ensamble previo con el accesorio (B).
 Fixe a peça (09) a montagem anterior com o acessório (B).

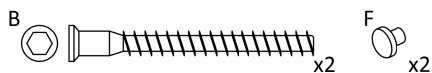
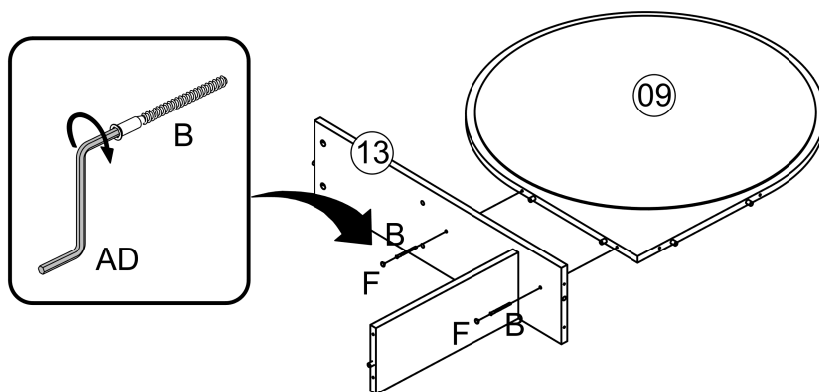

- 27** -Fix part (04) and part (10) with the accessory (B).
 Fixez la pièce (04) et la pièce (10) avec le accessoire (B).
 Fijar pieza (04) y pieza (10) con el accesorio (B).
 Fixe a peça (04) e a peça (10) com o acessório (B).

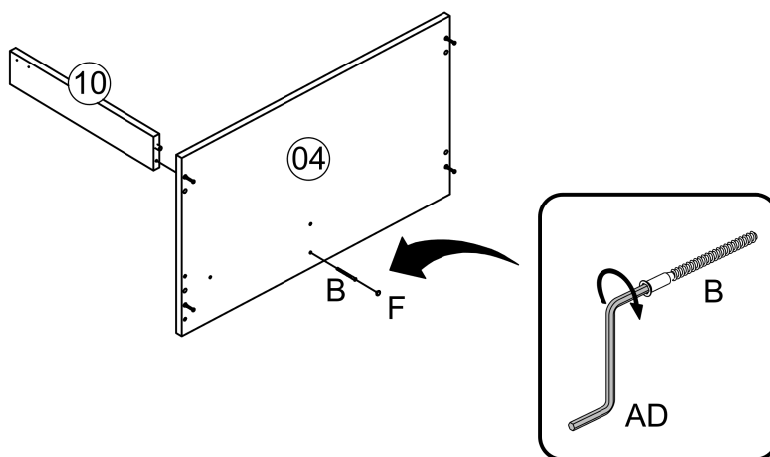

- 28** -Fix both previously assemblies (steps 26 and 27).
 Fixez les deux assemblages précédents (étapes 26 et 27).
 Fijar ambos ensambles previos (pasos 26 y 27).
 Fixe as montagens anteriores (passos 26 e 27).

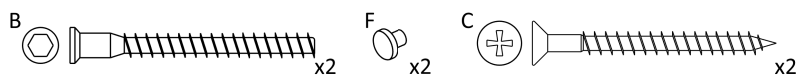
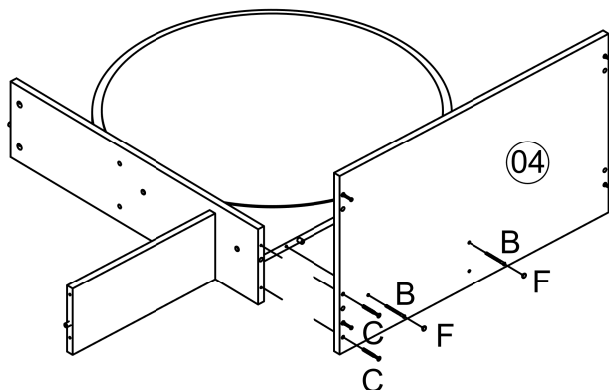

- 29** -Fix both previously assemblies (steps 24 and 28).
 Fixez les deux assemblages précédents (étapes 24 et 28).
 Fijar ambos ensambles previos (pasos 24 y 28).
 Fixe as montagens anteriores (passos 24 e 28).

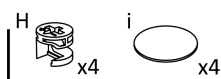
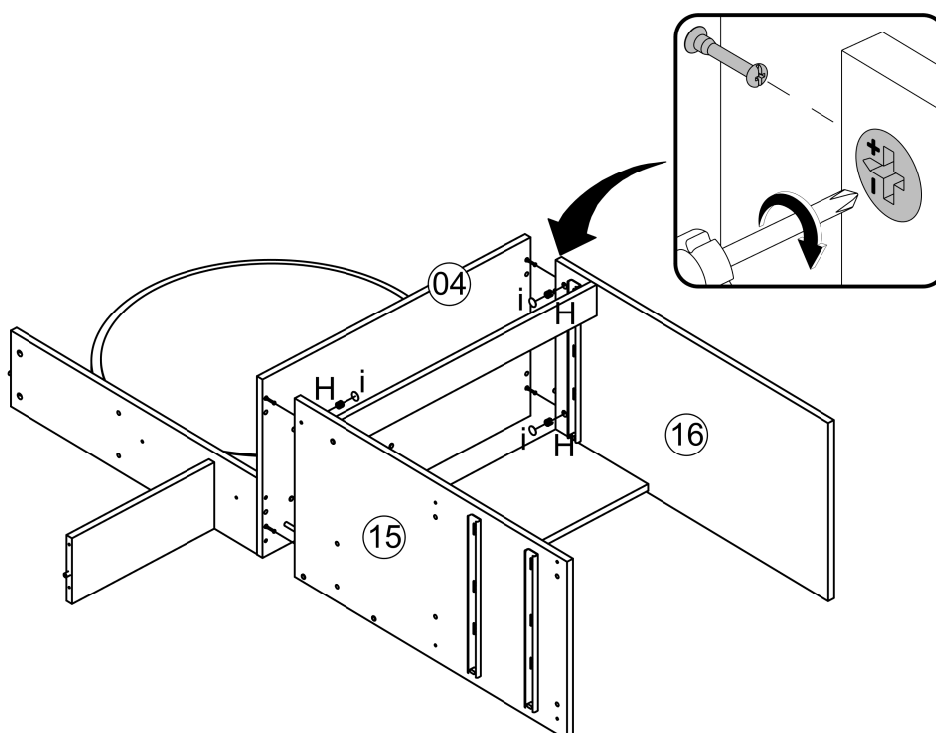

- 30** -Fix part (05) and part (12) with the accessory (C).
 Fixez la pièce (05) et la pièce (12) avec le accessoire (C).
 Fijar pieza (05) y pieza (12) con el accesorio (C).
 Fixe a peça (05) e a peça (12) com o acessório (C).

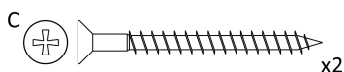
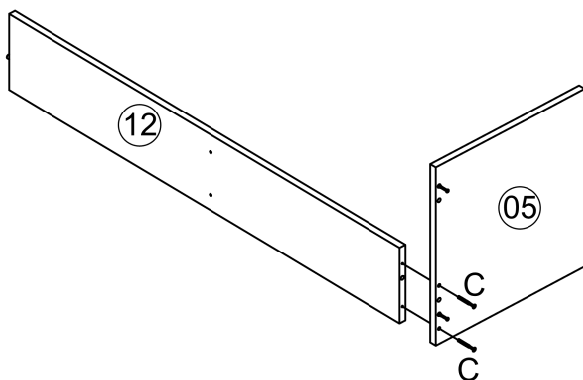

- 31** -Fix part (07), part (08) and part (14) to previous assembly with the accessory (H).
 Fixez la pièce (07), la pièce (08) et la pièce (14) à l'assemblage précédent avec l'accessoire (H).
 Fijar pieza (07), pieza (08) y pieza (14) a ensamble previo con el accesorio (H).
 Fixe a peça (07), a peça (08) e a peça (14) na montagem anterior com o acessório (H).

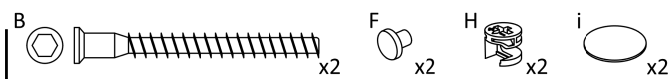
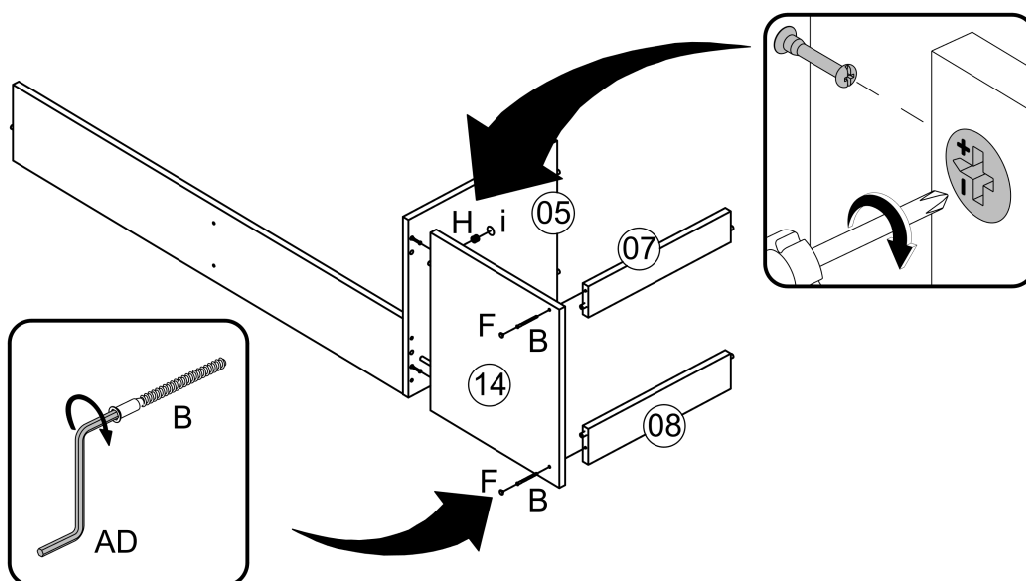

- 32** -Fix both previously assemblies (steps 29 and 31).
 Fixez les deux assemblages précédents (étapes 29 et 31).
 Fijar ambos ensambles previos (pasos 29 y 31).
 Fixe as montagens anteriores (passos 29 e 31).

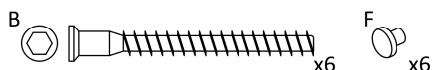
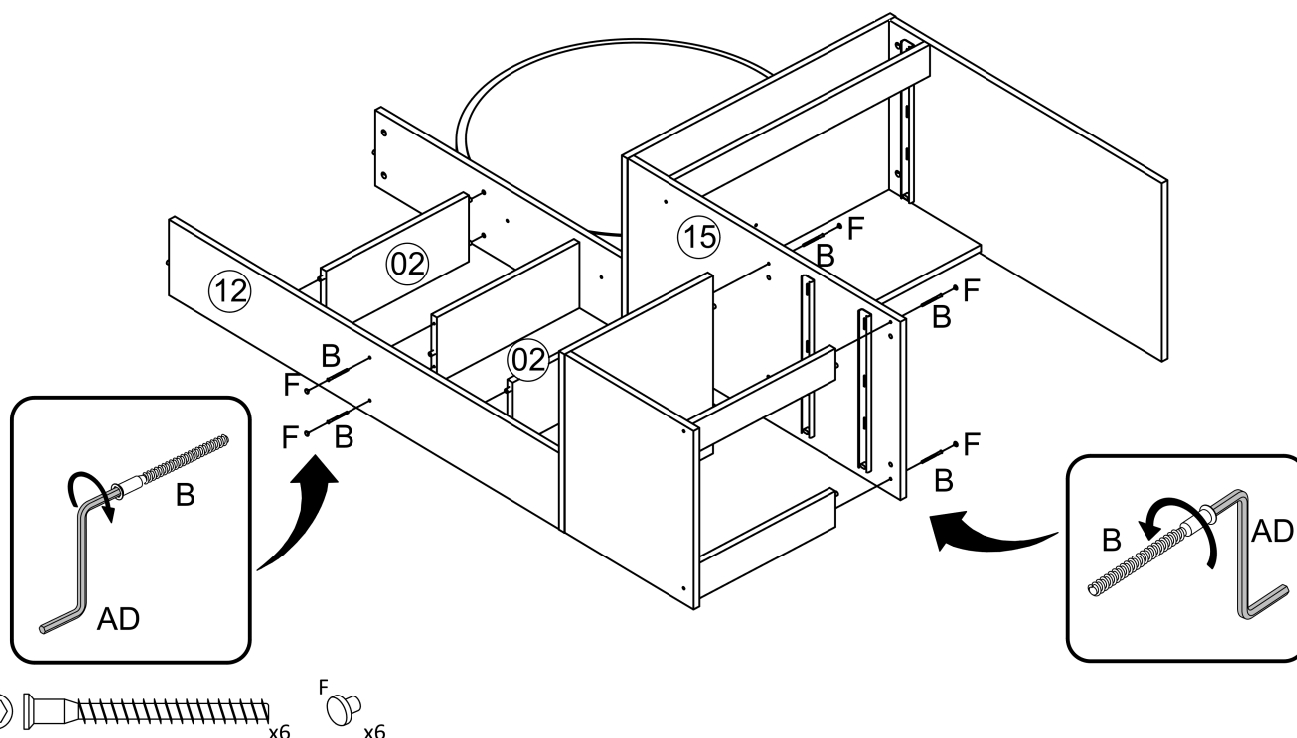

- 33** -Fix part (01) to previous assembly with the accessory (H).
 Fixez la pièce (01) à l'assemblage précédent avec l'accessoire (H).
 Fijar pieza (01) a ensamble previo con el accesorio (H).
 Fixe a peça (01) a montagem anterior com o acessório (H).

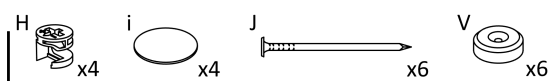
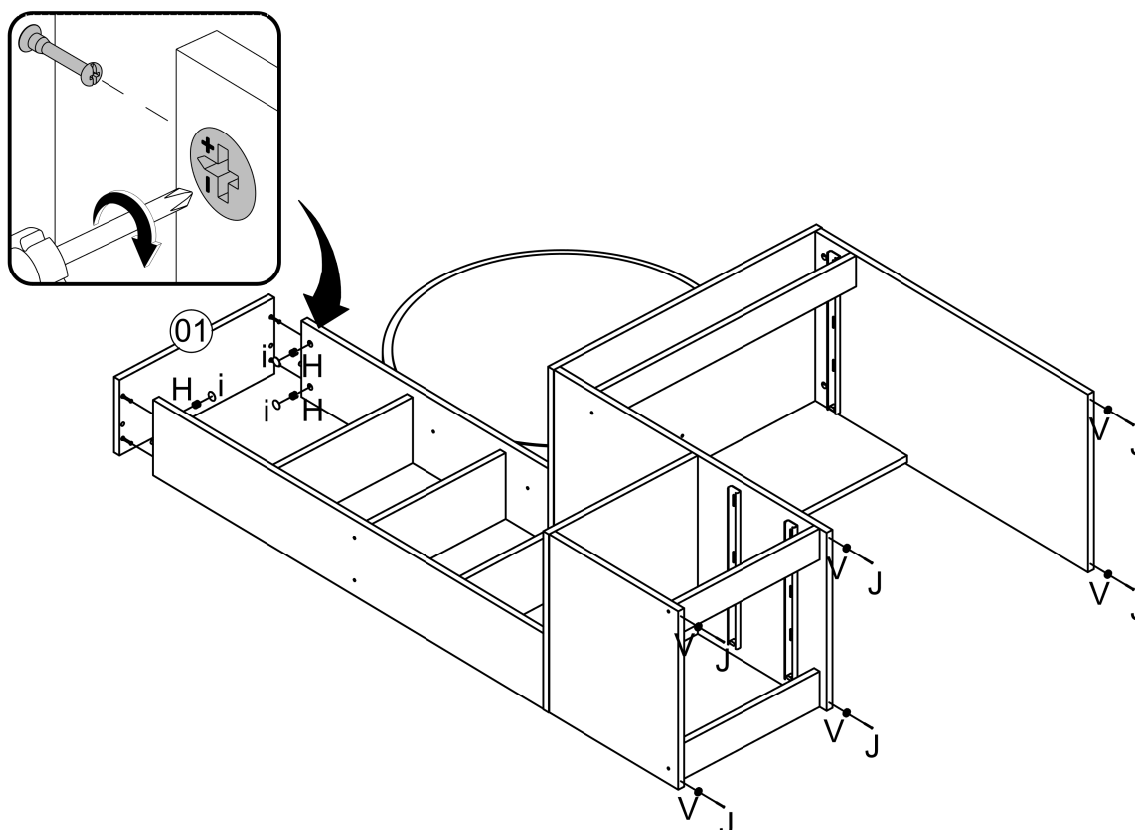

34 -Fix part (25) and part (26) to previous assembly with the accessory (J).

Fixez la pièce (25) et la pièce (26) à l'assemblage précédent avec l'accessoire (J).

Fijar pieza (25) y pieza (26) a ensamble previo con el accesorio (J).

Fixe a peça (25) e a peça (26) na montagem anterior com o acessório (J).

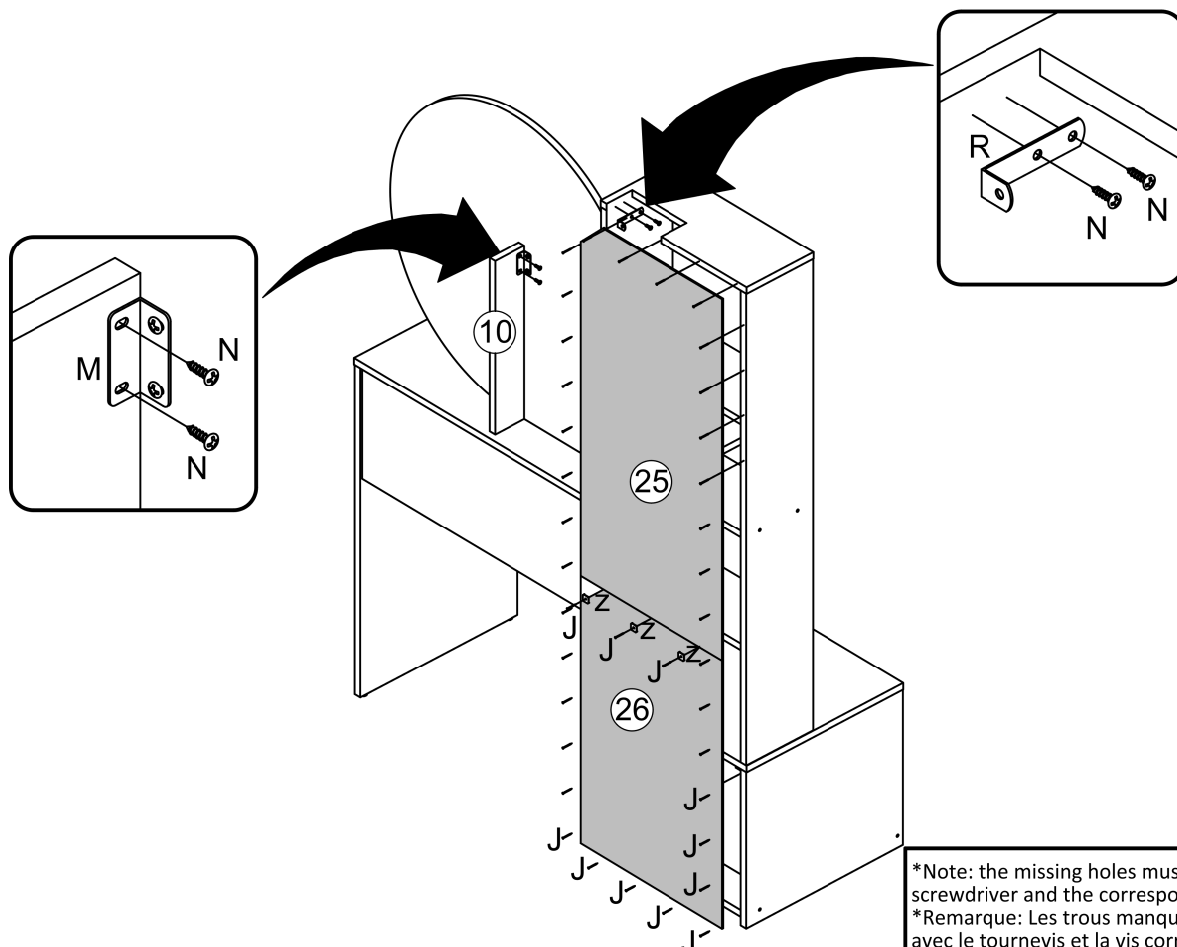

*Note: the missing holes must be made with the screwdriver and the corresponding screw.
*Remarque: Les trous manquants doivent être faits avec le tournevis et la vis correspondante.
*Nota: los agujeros faltantes deben hacerse con el destornillador y el tornillo correspondiente.
*Nota: As furações faltantes devem ser feitas com a chave e o parafuso correspondente.

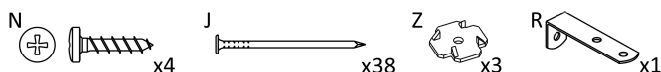

35 -Fix part (21), part (19) and part (22) with the accessory (C).

Fixez la pièce (21), la pièce (19) et la pièce (22) avec le accessoire (C).

Fijar pieza (21), pieza (19) y pieza (22) con el accesorio (C).

Fixe a peça (21), a peça (19) e a peça (22) com o acessório (C).

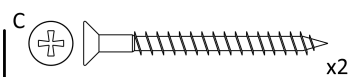
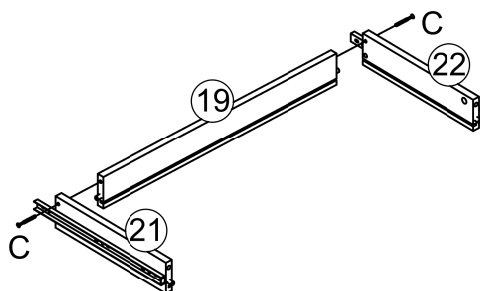

- 36** -Fix part (17) and part (23) to previous assembly with the accessory (H).
 Fixez la pièce (17) et la pièce (23) à l'assemblage précédent avec l'accessoire (H).
 Fijar pieza (17) y pieza (23) a ensamble previo con el accesorio (H).
 Fixe a peça (17) e a peça (23) na montagem anterior com o acessório (H).

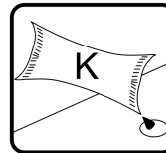
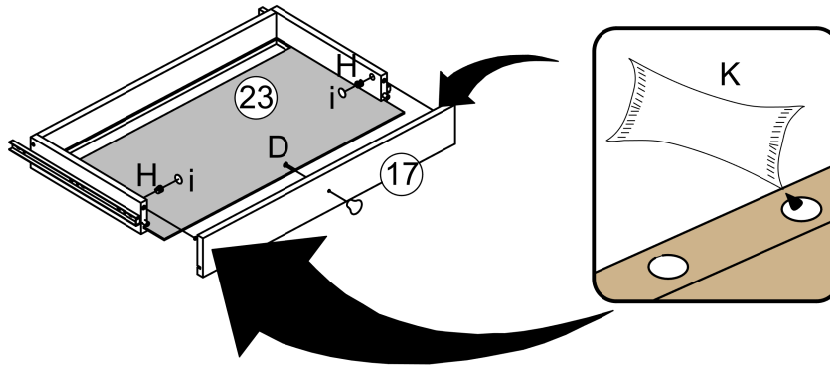

*Note: add glue (K) in the holes before placing the wooden dowel.
 *Remarque: ajouter de la colle (K) dans les trous avant de placer la cheville en bois
 *Nota: agregue el pegamento (K) en los agujeros antes de colocar el taquete.
 *Nota: utilize a cola (K) antes da colocação das Cavilhas.

- 37** -Fix part (21), part (20) and part (22) with the accessory (C).
 Fixez la pièce (21), la pièce (20) et la pièce (22) avec le accessoire (C).
 Fijar pieza (21), pieza (20) y pieza (22) con el accesorio (C).
 Fixe a peça (21), a peça (20) e a peça (22) com o acessório (C).

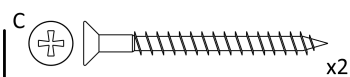
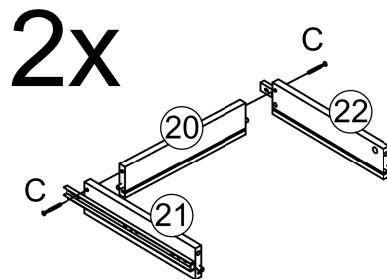

38 -Fix part (18) and part (27) to previous assembly with the accessory (H).

Fixez la pièce (18) et la pièce (27) à l'assemblage précédent avec l'accessoire (H).

Fijar pieza (18) y pieza (27) a ensamble previo con el accesorio (H).

Fixe a peça (18) e a peça (27) na montagem anterior com o acessório (H).

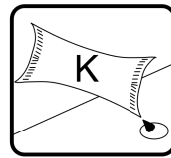
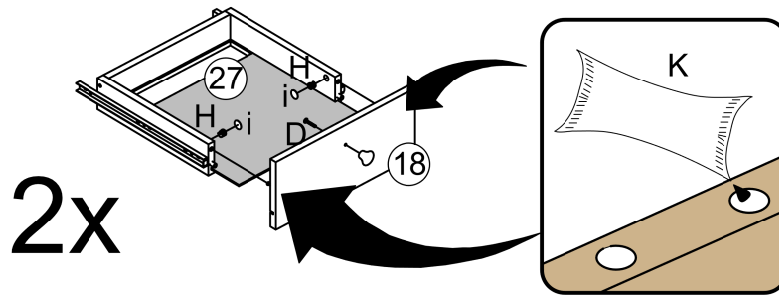

*Note: add glue (K) in the holes before placing the wooden dowel.
*Remarque: ajouter de la colle (K) dans les trous avant de placer la cheville en bois
*Nota: agregue el pegamento (K) en los agujeros antes de colocar el taquete.
*Nota: utilize a cola (K) antes da colocação das Cavilhas.

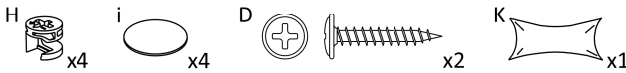

39 -Fix previously assemblies (steps 34, 36 and 38).

Fixez assemblages précédents (étapes 34, 36 et 38).

Fijar ensambles previos (pasos 34, 36 y 38).

Fixe as montagens anteriores (passos 34, 36 e 38).

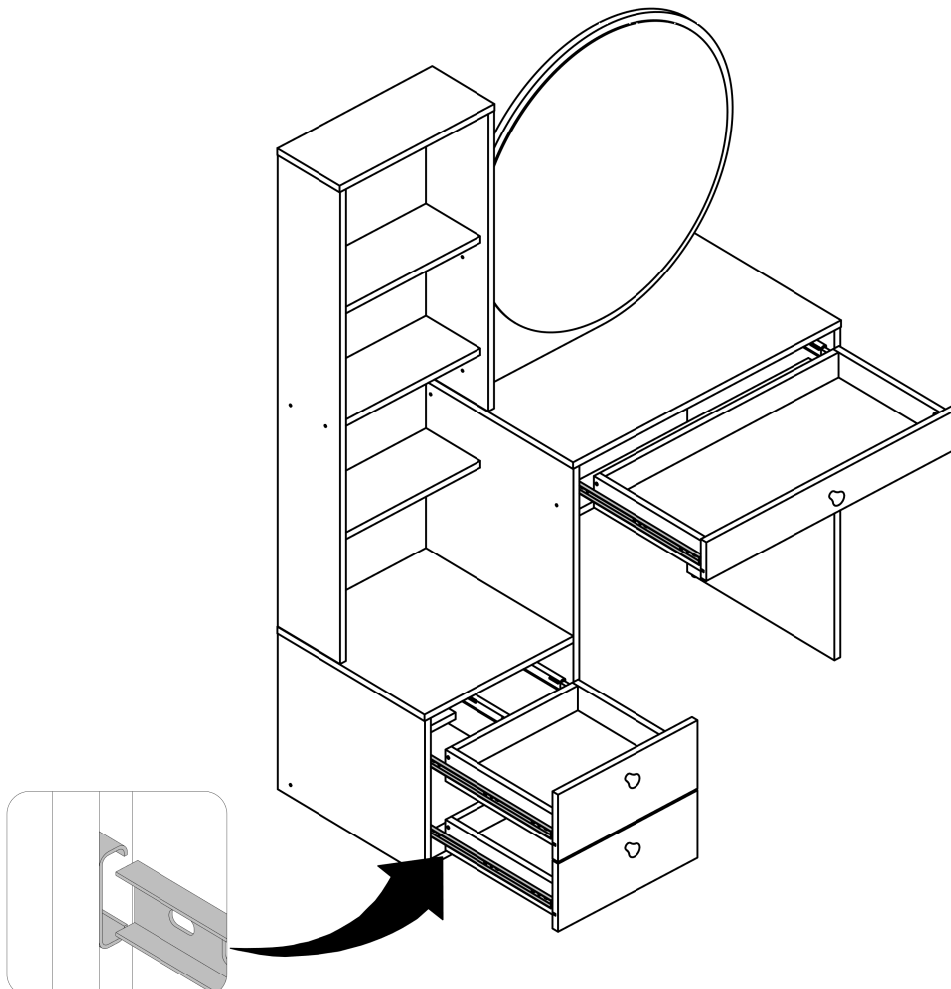

40 -Fix part (24) to previous assembly with the accessory (N).

Fixez la pièce (24) à l'assemblage précédent avec le accessoire (N).

Fijar pieza (24) a ensamble previo con el accesorio (N).

Fixe a peça (24) na montagem anterior com o acessório (N).

*Note: the missing holes must be made with the screwdriver and the corresponding screw.
*Remarque: Les trous manquants doivent être faits avec le tournevis et la vis correspondante.
*Nota: los agujeros faltantes deben hacerse con el destornillador y el tornillo correspondiente.
*Nota: As furações faltantes devem ser feitas com a chave e o parafuso correspondente.

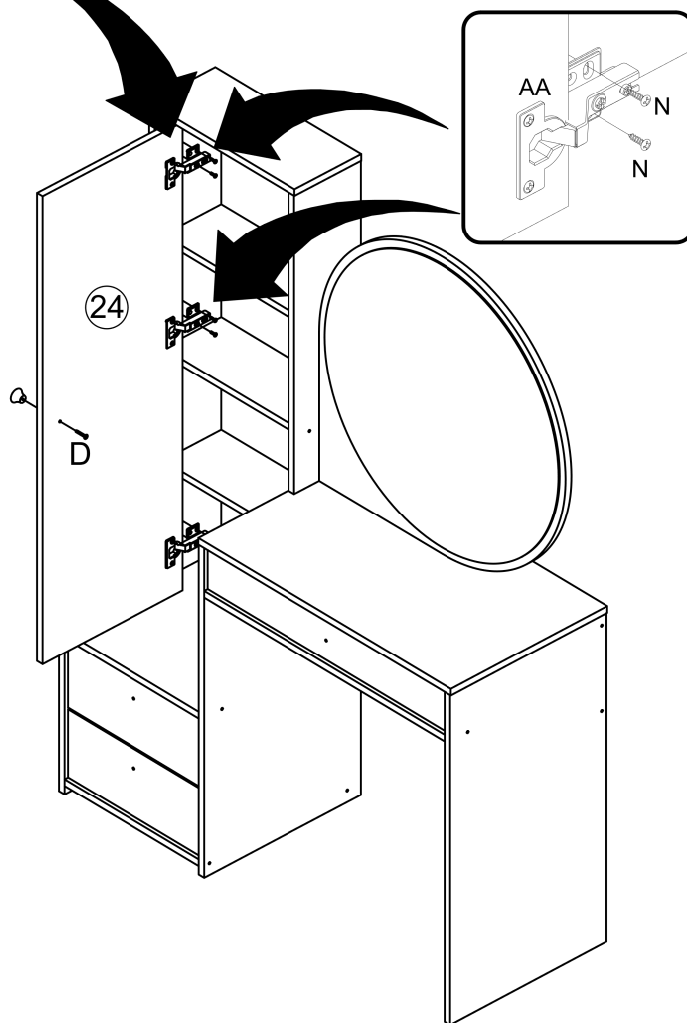
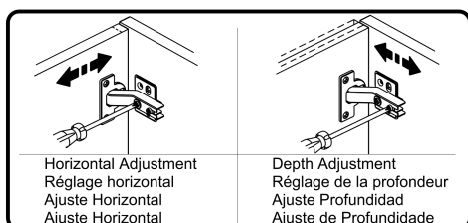

41 -Fix furniture to the wall.
Fixez le meuble au mur.
Fijar mueble a la pared.
Fixe o móvel na parede.

