

Item	Caixa Caja Box	Qty Ctd Qty	Descrição Descripción Description	Medidas (mm) Dimensiones (mm) Size (measurements) (mm)
01	2/5	01	Rodapé Frontal frente pie de página Front Footer	2595x73x12
02	2/5	03	Travessa do rodapé Carril pie Baseboard crosspiece	470x73x12
03	2/5	01	Rodapé Traseiro Pie de página trasera Rear Footer	2595x73x12
04	2/5	01	Base Base Base	2595x500x12
05	1/5	01	Lateral esquerda Lateral izquierda Left side	2250x500x12
06	4/5	01	Divisão Inferior Esquerda División inferior izquierda Bottom Left Division	700x410x12
07	3/5	01	Divisão Superior Esquerda División superior izquierda Upper Left Division	1045x350x12
08=14	4/5	01	Tampo das Gavetas Tapa del cajón Drawer Top	780x410x12
09=17	3/5	02	Prateleira Estante Shelf	768x350x12
10	3/5	01	Divisão Central División central Central Division	845x350x12
11	3/5	01	Prateleira Fixa Estante fijo Fixed Shelf	500x350x12
12	4/5	01	Divisão Inferior Direita División inferior derecha Lower Right Division	700x410x12
13	3/5	01	Divisão Superior Direita División superior derecha Upper Right Division	1045x350x12
14=08	4/5	01	Tampo das Gavetas Tapa del cajón Drawer Top	780x410x12
15	2/5	01	Chão do maleiro Piso del portaequipajes Floor of the closet top shelf	2595x410x12
16	3/5	02	Ripa do maleiro Portaequipajes de ripa Lath of the closet top shelf	350x73x12
17=09	3/5	02	Prateleira Estante Shelf	768x350x12
18	2/5	01	Tampo Superior Tapa Superior Top Panel	2595x500x12
19	1/5	01	Lateral Direita Lado derecho Right side	2250x500x12
20	1/5	04	Ripa Lateral Ripa lateral Lateral Ripa	500x80x25
21	2/5	01	Moldura Superior Marco superior frame Superior	2699x73x12
22	2/5	02	Moldura Lateral Marco lateral Lateral Frame	2177x73x12
23	2/5	01	Fundo Superior Fondo Superior Top Bottom	2617x365x3
24	1/5	02	Fundo Central Fondo central Central Fund	1773x520x3
25	1/5	04	Fundo Fondo Bottom	1773x389x3
26	5/5	04	Painel Central Panel central Center pane	1139x522x12
27	5/5	04	Painel Panel Panel	1139x522x12
28	1/5	04	Moldura Frontal da Porta Marco de la puerta delantera Marco de la puerta delantera	2090x100x25
29	4/5	04	Frente de gaveta Frente de cajón Front of drawer	735x220x12
30	3/5	08	Lado de gaveta Lado del cajón Side of drawer	350x180x12
31	4/5	04	Fundo de gaveta recortado Fondo de cajón recortado Drawer bottom trimmed	705x361x3
32	4/5	04	Ripa de trás Malla detrás Rear lath	718x180x12

HENN

Ind. e Com. de Móveis Henn
Mondai - SC - Brasil

+55 49 3674.3500

@moveishenn
www.henn.com.br

INSTRUÇÕES DE MONTAGEM

INSTRUCCIONES DE MONTAJE
ASSEMBLY INSTRUCTIONS

ROUPEIRO PALACE 02 PORTAS DESLIZANTES
ARMARIO PALACE 02 PUERTAS DESLIZANTES | PALACE 02 WARDROBE SLIDING DOORS

D237-106 Rústico/Off White
D237-130 Castanho HP

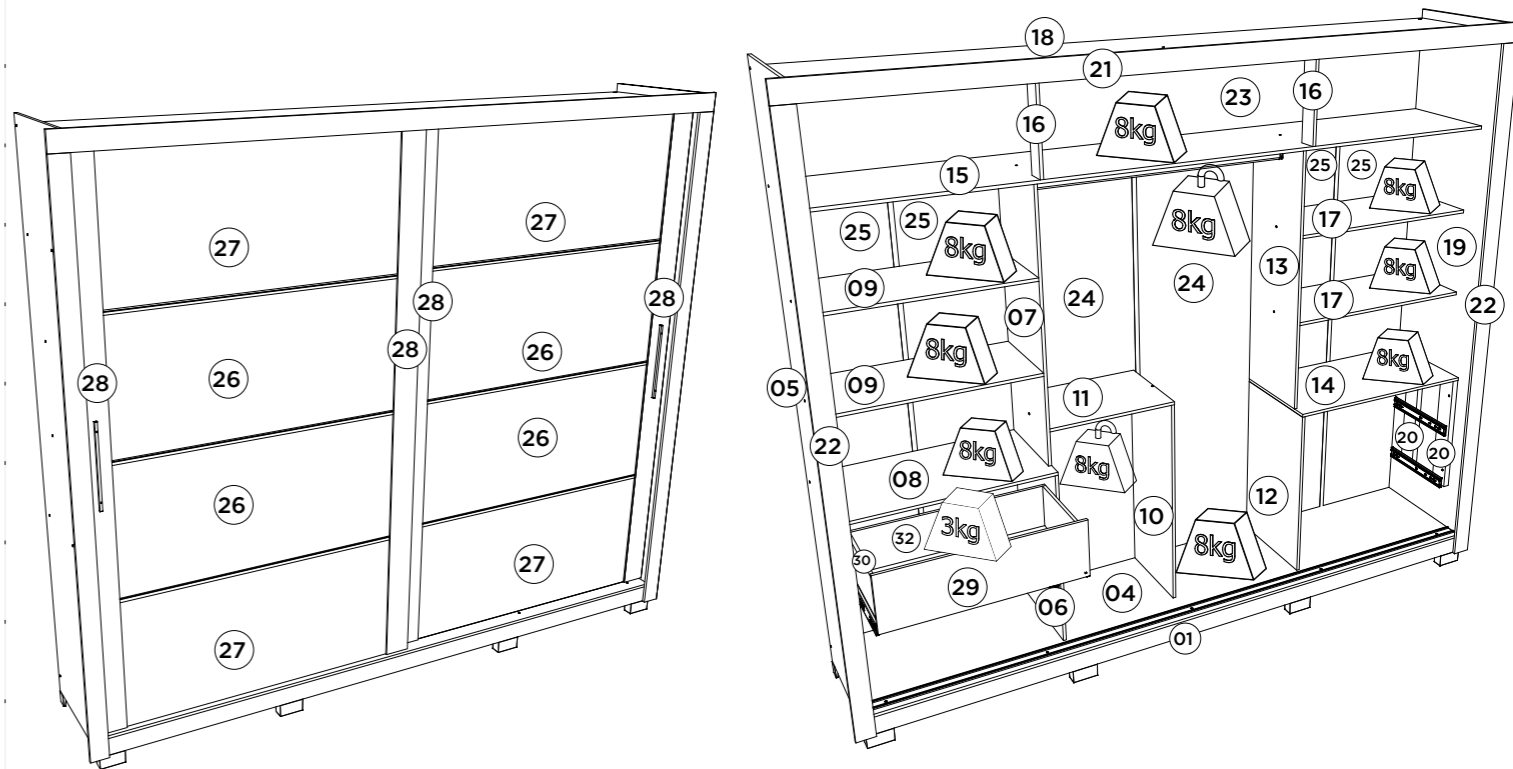

Pesos máximos recomendados com carga distribuída
Peso máximo recomendado con la carga distribuida
Recommended maximum weights with evenly distributed.

AVISO

Para limpeza de seu móvel, use uma flanela seca ou umedecida, e não utilize produtos químicos que possam danificar seu produto.

SISTEMA DE MONTAGEM

O sistema de montagem dos produtos, funciona de acordo com a ordem crescente dos números indicados no desenho. Ex: 01, 02, 03, 04... até a conclusão da montagem.

ASSISTÊNCIA TÉCNICA

Para solicitação de Assistência Técnica você consumidor deverá entrar em contato com o Lojista o qual você realizou a compra deste produto e solicitar a assistência técnica das peças avariadas. A garantia abrange todas as peças, partes e componentes que eventualmente venham apresentar defeito de fabricação no prazo de 03 (três) meses, contando a partir da entrega do produto ao consumidor, mediante nota fiscal de compra. Se houver qualquer alteração na estrutura do produto ou ocorrer defeito por negligência do montador/consumidor em relação a instrução de montagem e manuseio, não será fornecido assistência técnica gratuita.

ADVERTENCIA

Para limpeza de su móvil, use una flanela seca o húmeda, y no utilice productos químicos que puedan dañar su producto.

SISTEMA DE MONTAJE

El sistema de montaje de los productos funciona de acuerdo con el orden creciente de los números indicados en el dibujo. Ej.: 01, 02, 03, 04... hasta la conclusión del montaje.

ASISTENCIA TÉCNICA

Para solicitar Asistencia Técnica, el consumidor debe comunicarse con el Comercio que usted realizó la compra de este producto y solicita asistencia técnica para las partes dañadas. La garantía cubre todas las partes, piezas y componentes que eventualmente puedan presentar defecto de fabricación en el plazo de 03 (tres) meses, contados a partir de la entrega del producto al consumidor, mediante factura de compra. Si se produce algún cambio en la estructura del producto o se produce un defecto por negligencia del montador/consumidor en relación con las instrucciones de montaje y manipulación, no se prestará asistencia técnica gratuita.

NOTICE

To clean your furniture, use a dry or wet cloth, and do not use chemicals that may damage your product.

ASSEMBLY SYSTEM

The products' assembly system works according to the increasing order of the indicated numbers. For example: 01, 02, 03, 04 ... to the end of the assembly.

TECHNICAL ASSISTANCE

To request Technical Assistance, the consumer must contact the retailer from whom you purchased this product and request technical assistance for the damaged parts. The warranty covers all parts, parts and components that may eventually present a manufacturing defect within a period of 03 (three) months, counting from the delivery of the product to the consumer, by means of a purchase invoice. If there is any change in the structure of the product or defect occurs due to negligence of the assembler/consumer in relation to the assembly and handling instruction, free technical assistance will not be provided.

Ferragens | Herrajes | Hardware

A 08x Parafuso 4,5x50mm CHT. Tornillo 4,5x50mm CHT. Screw 4,5x50mm CHT.	B 08x Parafuso 4,0x35mm CHT. Tornillo 4,0x35mm CHT. Screw 4,0x35mm CHT.	C 29x Parafuso 3,5x40mm CHT. Tornillo 3,5x40mm CHT. Screw 3,5x40mm CHT.	D 32x Parafuso 3,5x22mm CHT. Tornillo 3,5x22mm CHT. Screw 3,5x22mm CHT.	E 04x Parafuso 3,5x30mm FLA. Tornillo 3,5x30mm FLA. Screw 3,5x30mm FLA.	F 81x Parafuso 3,5x12mm FLA. Tornillo 3,5x12mm FLA. Screw 3,5x12mm FLA.	G 127x Parafuso 3,5x12mm CHT. Tornillo 3,5x12mm CHT. Screw 3,5x12mm CHT.
H 08x Parafuso 3,0x16mm CHT. Tornillo 3,0x16mm CHT. Screw 3,0x16mm CHT.	I 16x Prego 12x12mm Anelado Clavo 12x12mm Anillado Ringed Nails 12x12mm	J 202x Prego 10x10mm Clavo 10x10mm Nail 10x10mm	K 56x Fixador de fundos Fijador de fondos Bottom fixer	L 106x Cavilha 5x25mm Cinta 5x25mm Dowel 5x25mm	M 30x Cantoneira plástica Cantoneira plástica Plastic angle brackets	N 08x Cantoneira suporte triangular Cantoneira soporte triangular Triangle support angle
O 08x Porca cilíndrica Tuerca cilíndrica Cylindrical nut	P 09x Pé "U" 50x40x100mm Pie "U" 50x40x100mm 50x40x100mm "U" feet	Q 13x Conector de montagem Conector de montaje Mounting connector	R 14x Suporte metal Soporte metálico Metal support	S 02x Puxador Alumínio 323mm Tirador Alumínio 323mm Handle Aluminum 323mm	T 04x Suporte cabideiro Soporte de percha Coat hanger support	U 01x Cabideiro Alum. 1027mm Alu 1027mm percha Alu coat hanger 1027mm
V 01x Cabideiro Alum. 479mm Alu 479mm percha Alu coat hanger 479mm	W 04x Corredora telescópica Corredera telescópica Telescopic slide	X 01x Kit Rodízio CM110 (2Portas) Kit de rodillos CM110 (2Puertas) CM110 Pulley Kit (2Doors)	Y 03x Perfil "H" 1758mm Perfil "H" 1758mm Profile "H" 1758mm	Z 01x Trilho Alumínio 2593mm Riel Alumínio 2593mm Aluminum Rail 2593mm	AA 01x Trilho PVC 2593mm Carril PVC 2593mm PVC Rail 2593mm	AB 02x Sachê de cola Bolsa de pegamento Glue bag
AC 02x Giz de correção Tiza de corrección Chalk of correction	AD 28x Adesivo tapa parafuso 10mm Adhesivo tapón de tornillo 10mm Bolt cover adhesive 10mm	AE 01x Etiqueta resinada Henn Etiqueta resinada Henn Henn resin label	HENN			

Requisitos para montagem
Requisitor para la montaje
Assembly Requirements

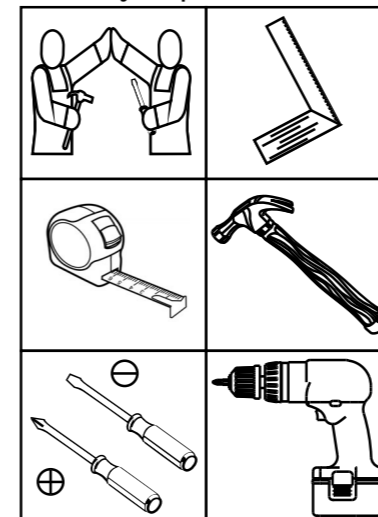

Imagens meramente ilustrativas
Imágenes meramente ilustrativas
Images for illustration only

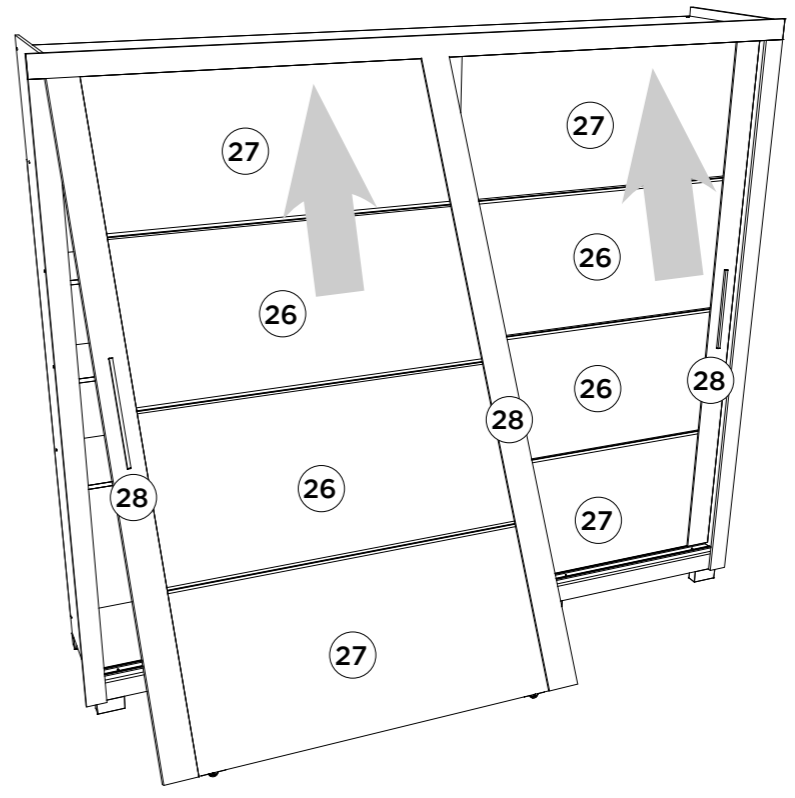
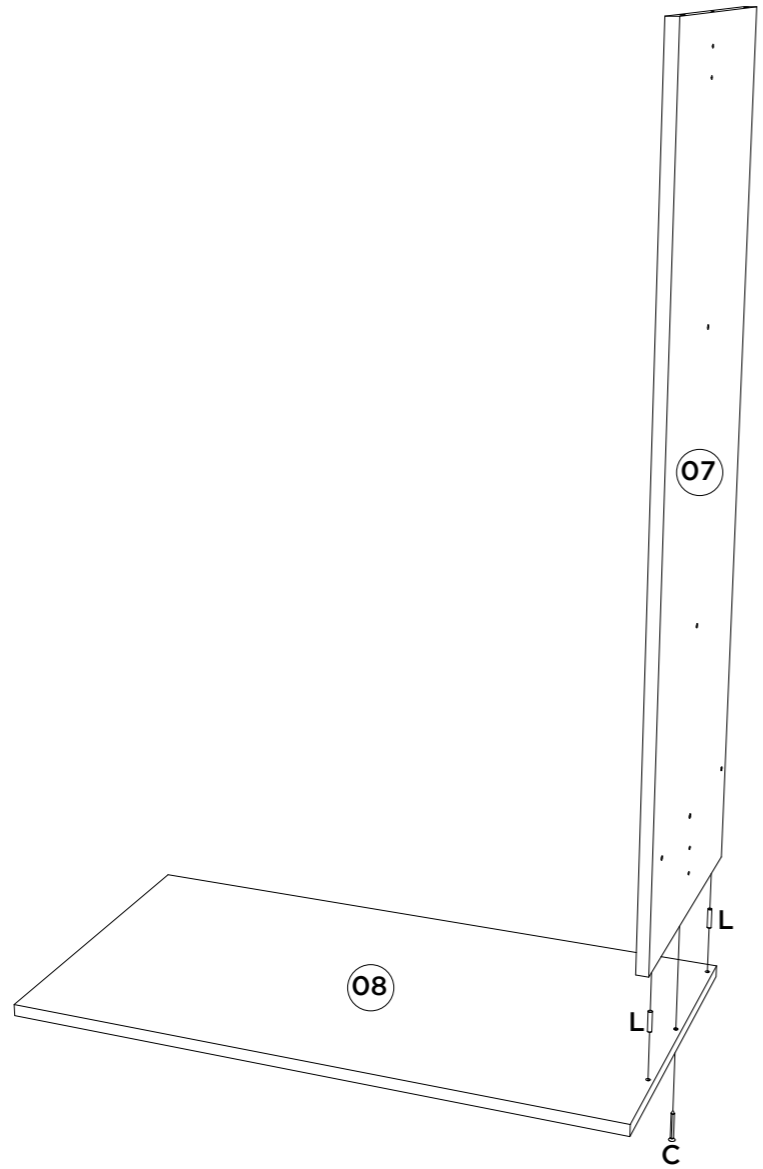
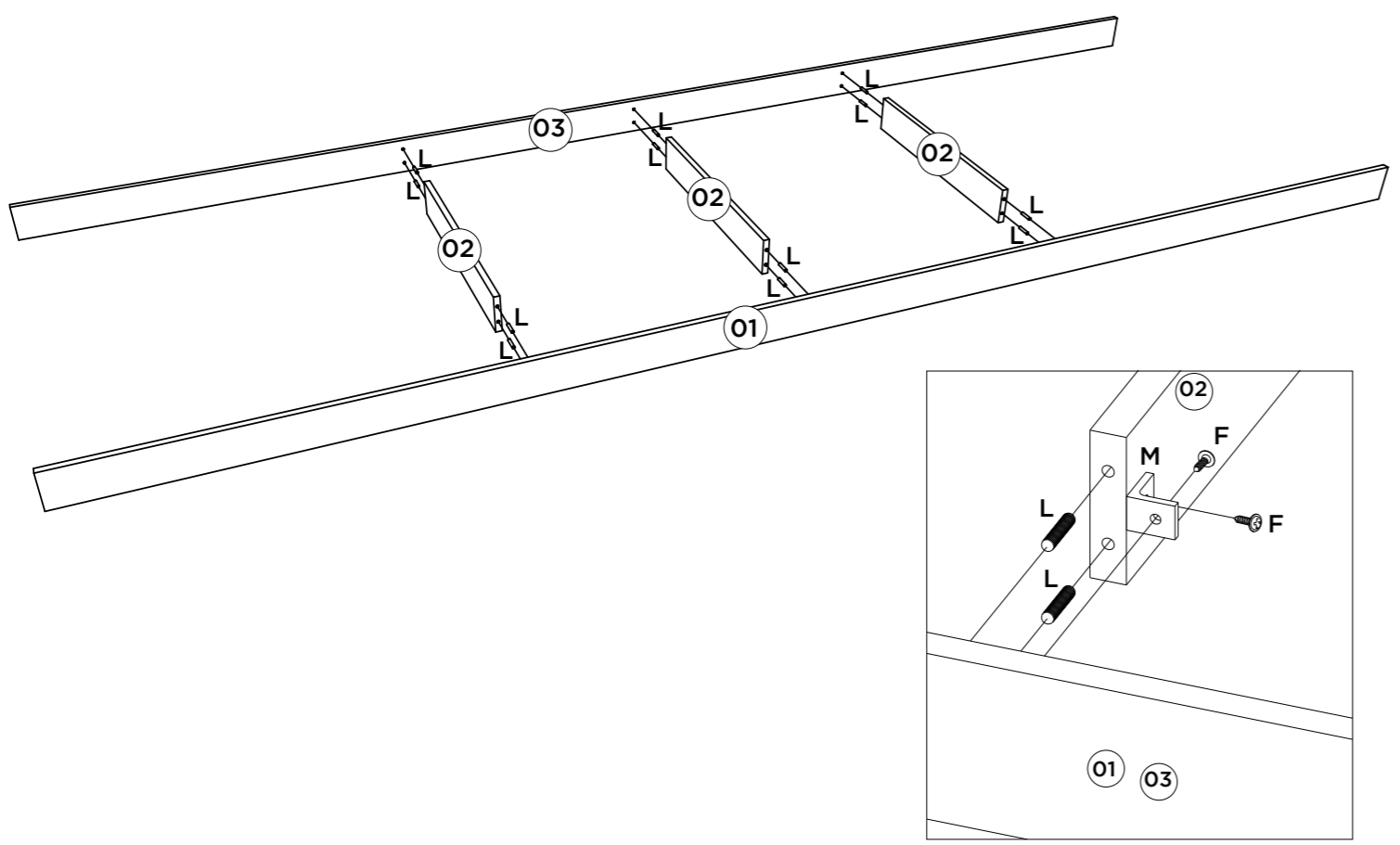

Para a colocação das portas nos trilhos encaixe primeira a porta no trilho de PVC superior (AA) e em seguida no trilho de alumínio inferior (Z).

Para la colocación de las puertas en la pista instalación de la puerta en la primera banda superior PVC (AA) y luego el riel de aluminio inferior (Z).

For placing the doors on the rails fitting the door on the PVC rail first (AA) and then on the lower aluminum rail (Z).



4x

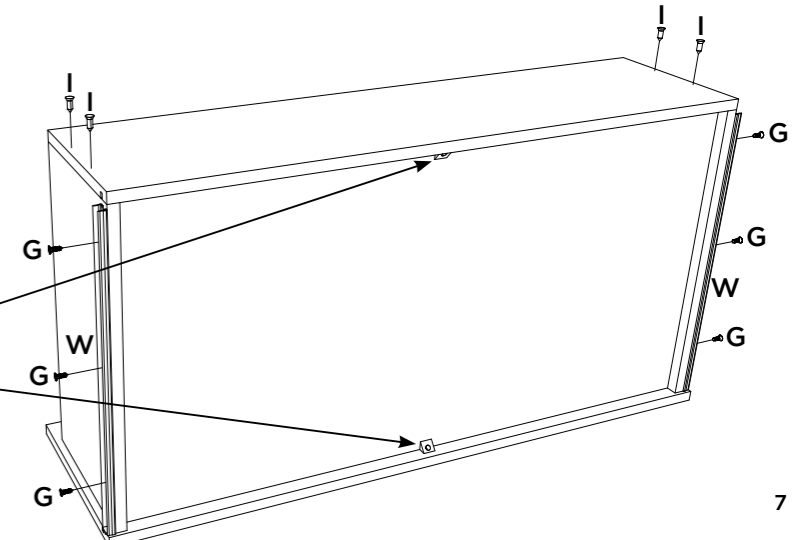
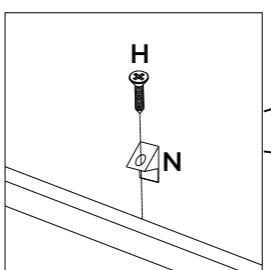
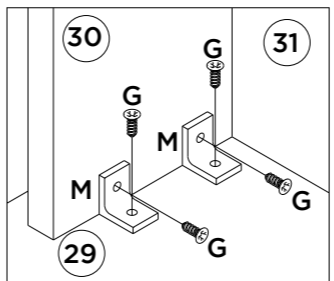
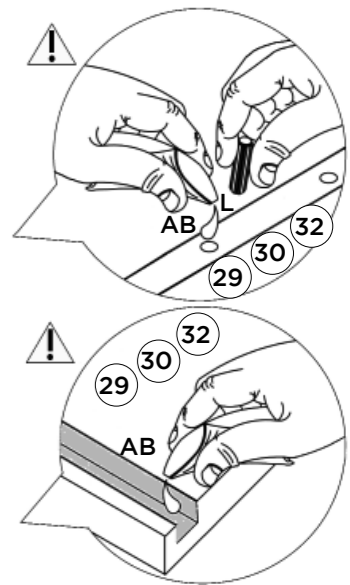
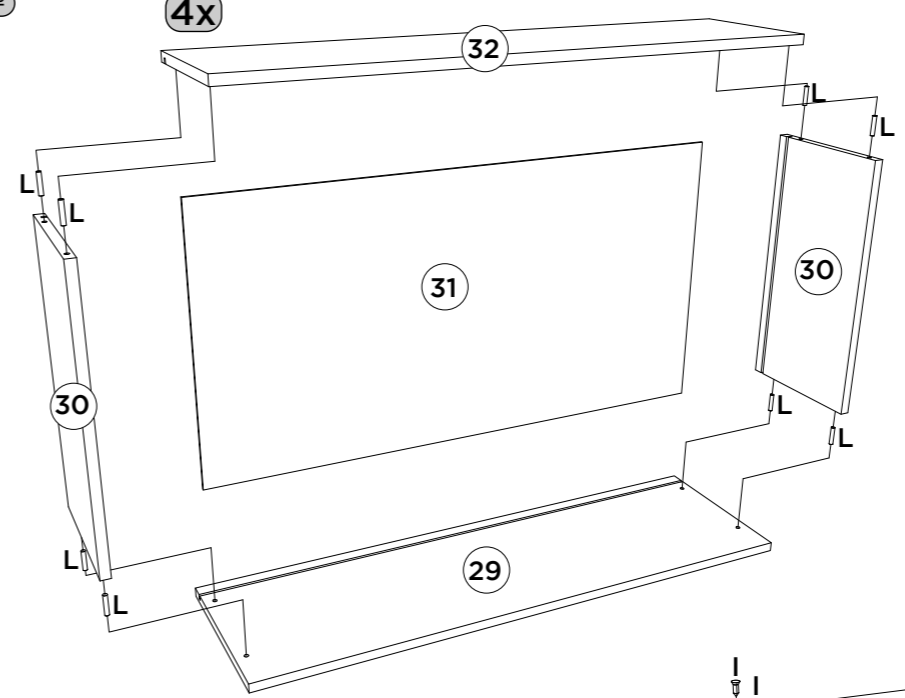

2x

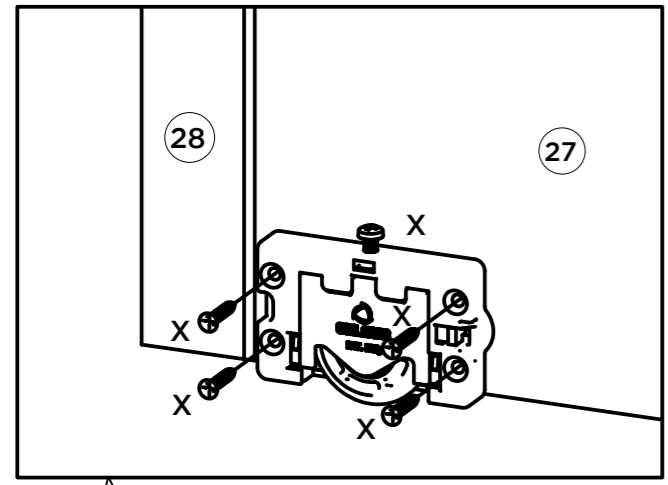

- Deixar a Roldana (X) encostada na Moldura (28)
- Deje la polea (X) contra el marco (28)
- Leave the pulley (X) against the frame (28)

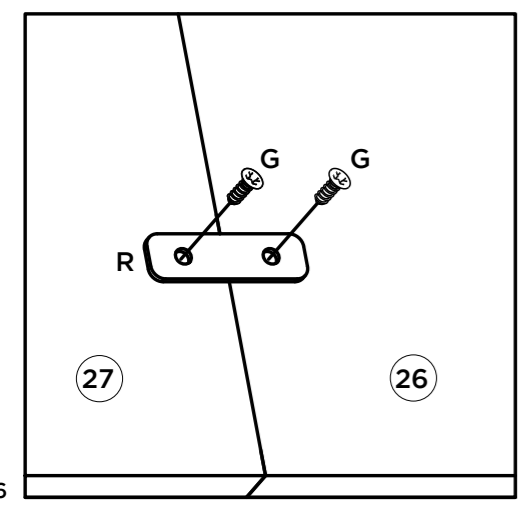
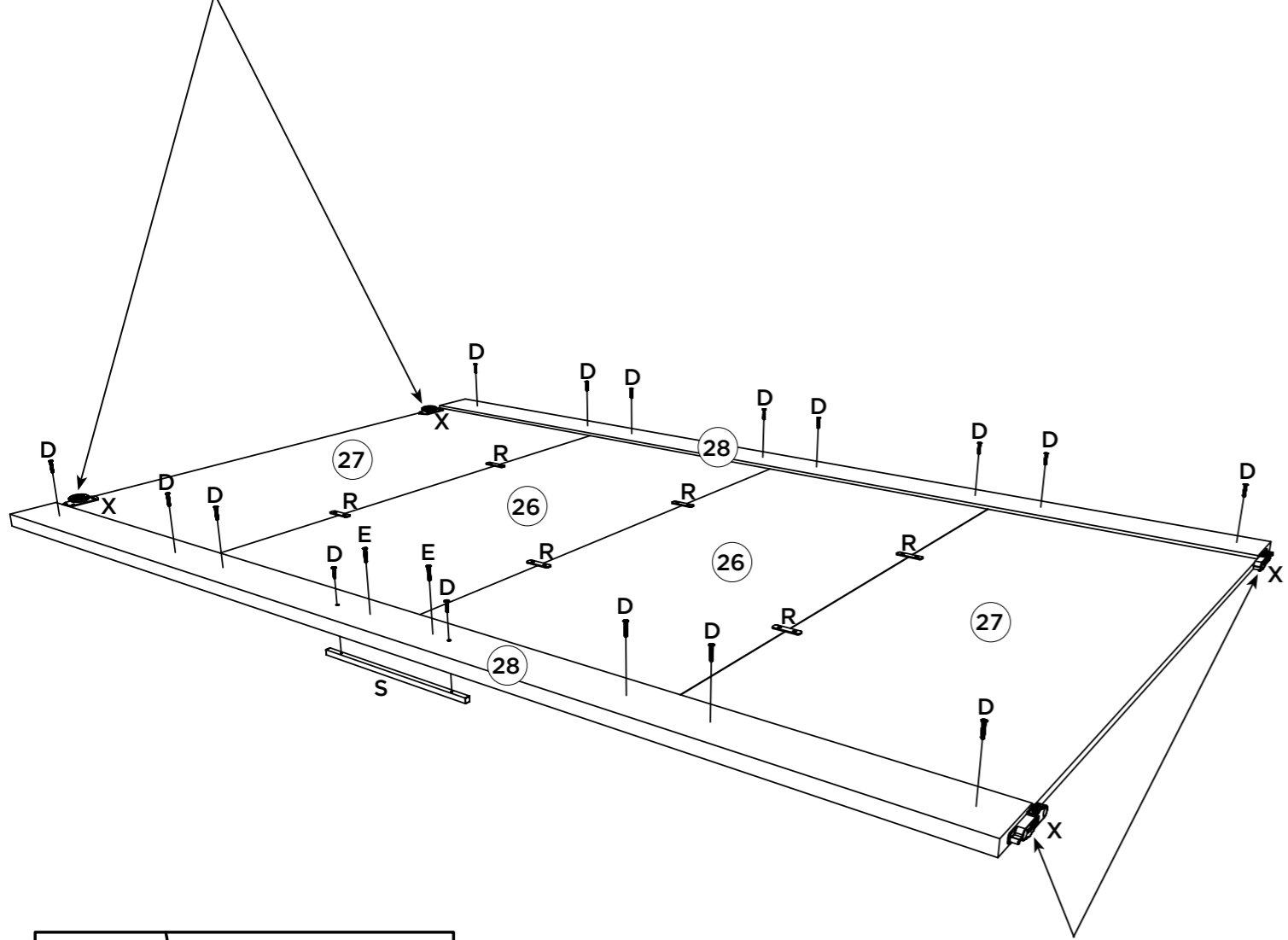

- Pinação na Moldura (28)
- Pinação el marco (28)
- Pinação the frame (28)

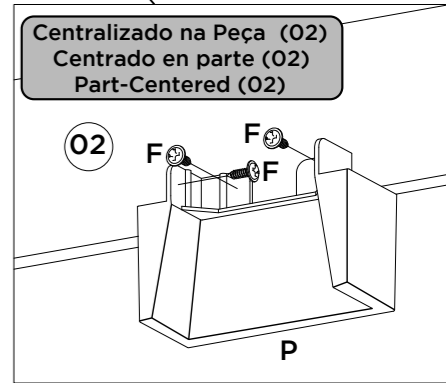
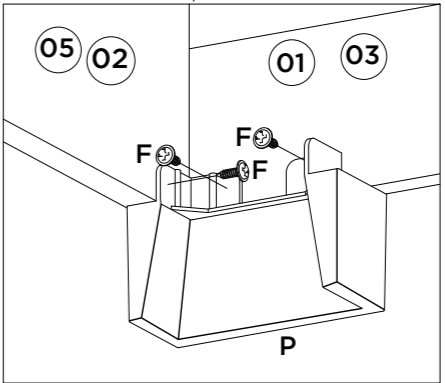
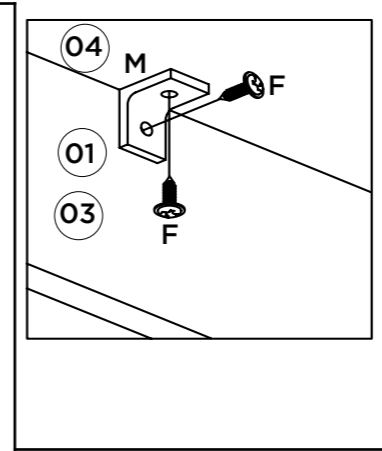
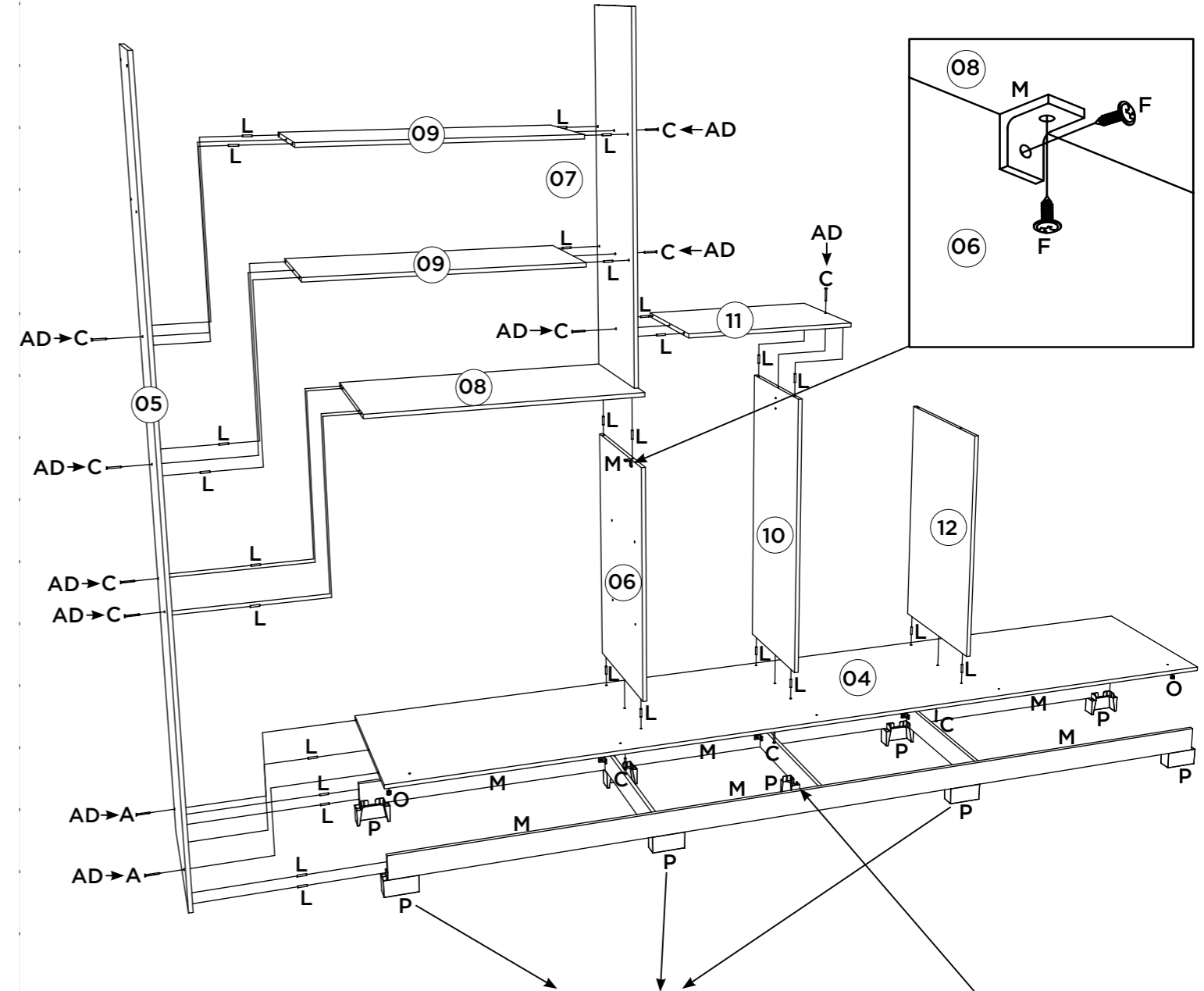
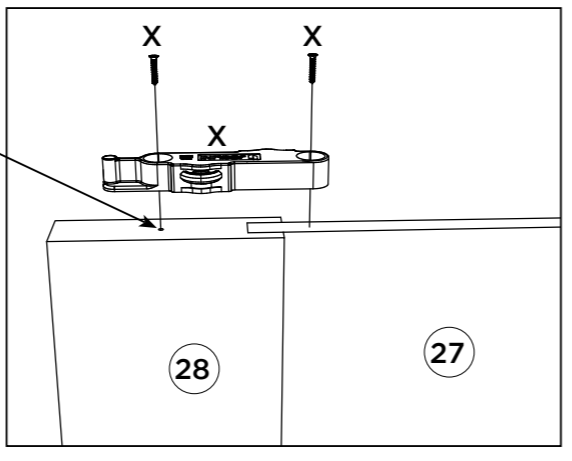

Centralizado na Peça (02)
Centrado en parte (02)
Part-Centered (02)

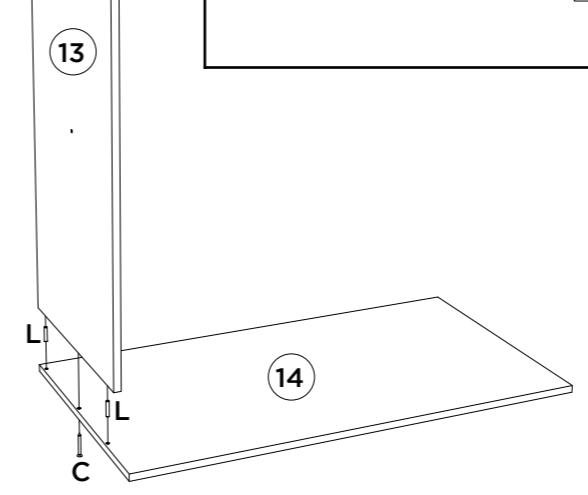

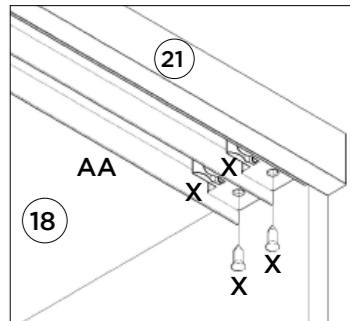
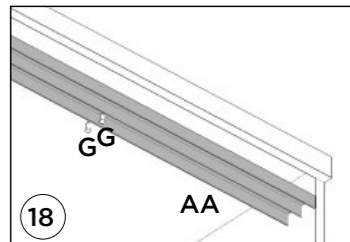
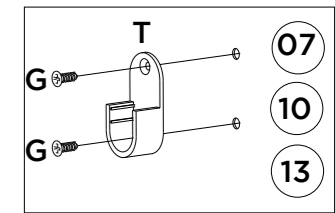
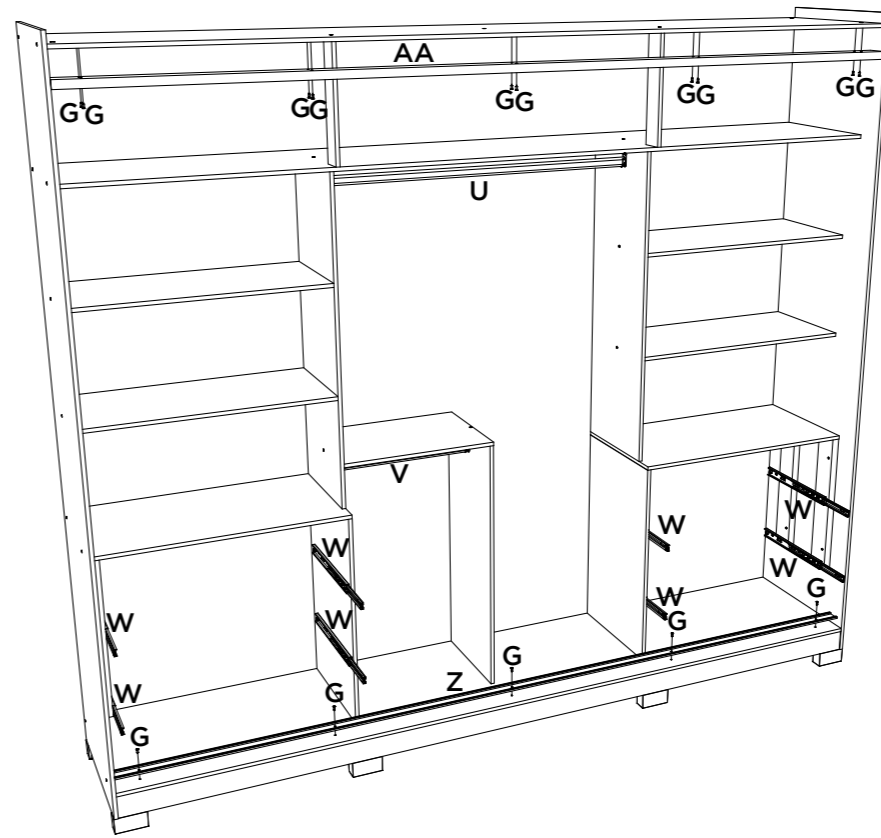
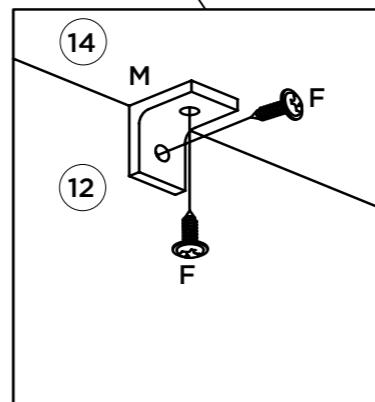
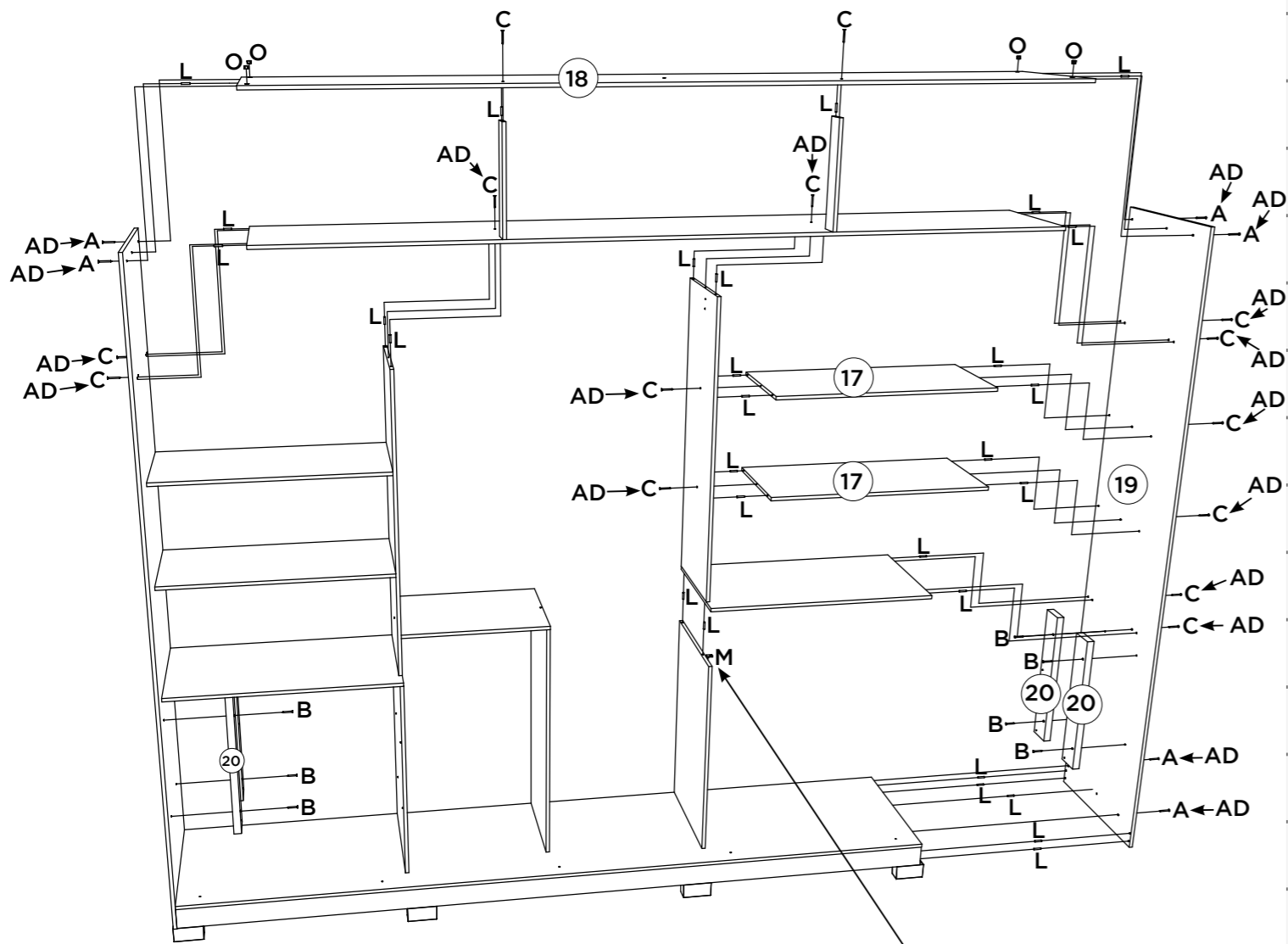
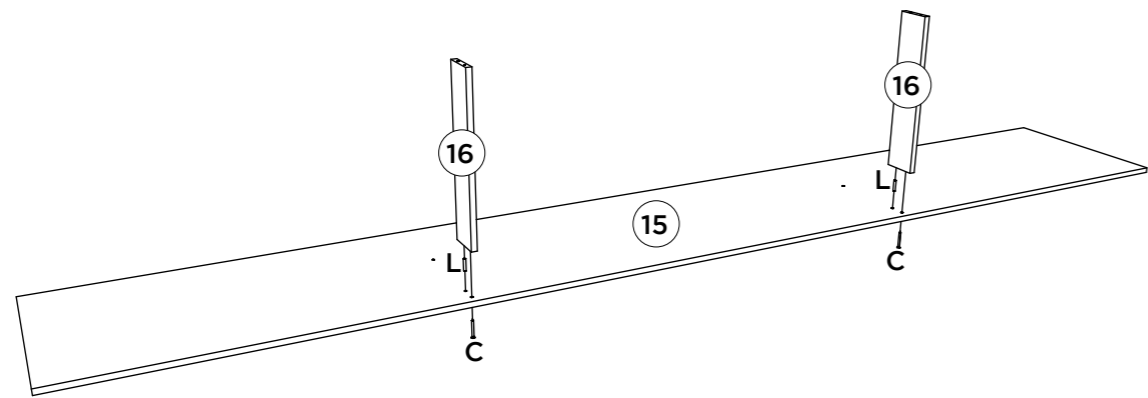

Vídeo: Dicas para fixar a Corrediça
 Vídeo: Consejos para arreglar la diapositiva
 Video: Tips for Fixing the Slide

