

## 8655 - GR DUETTO 3 PTS DE CORRER E 6 GAV

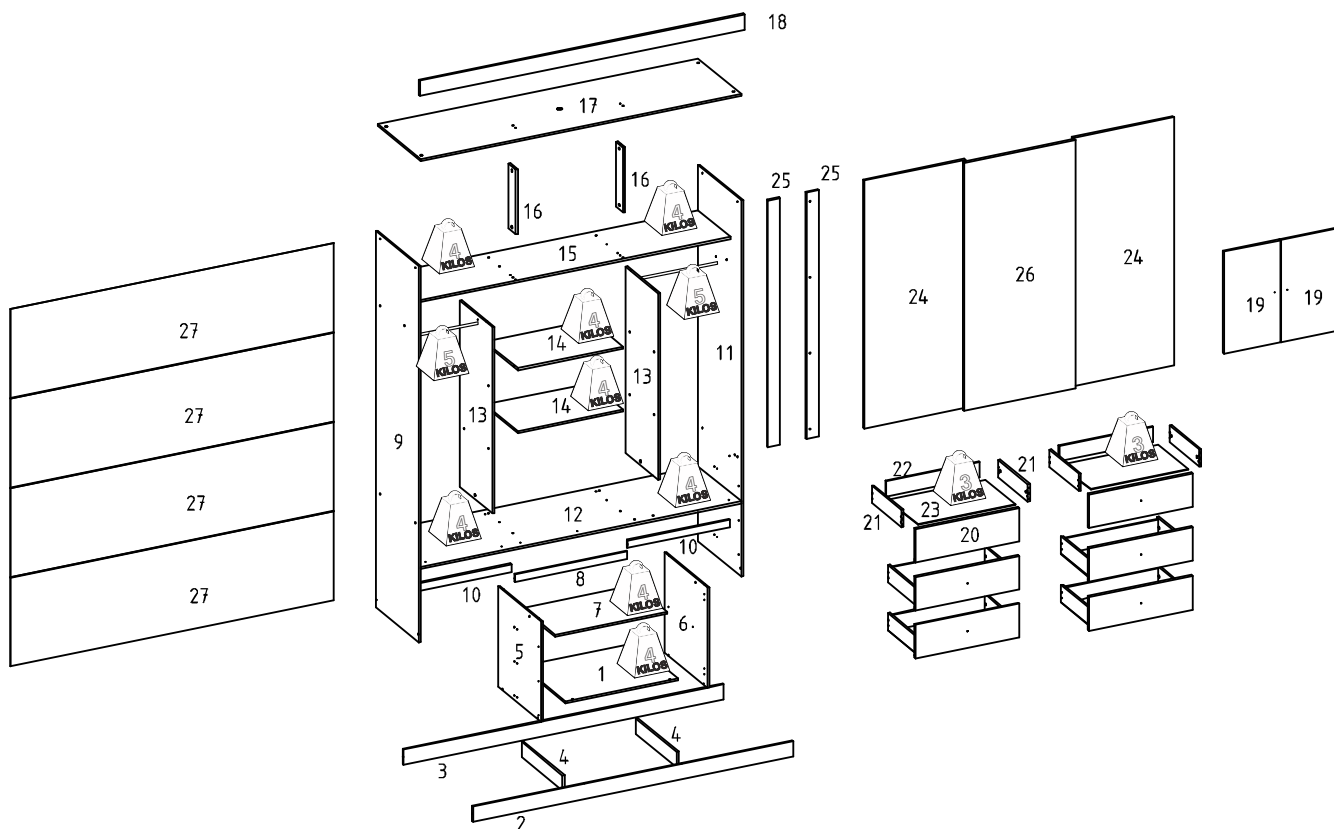

### LISTA DE PEÇAS / Pieces List / Lista de Piezas

SEQ.	REF.	DESCRIÇÃO	DESCRIPTION	DESCRIPCIÓN	MAT.PRIMA	COMP.	LARG.	ESP.	QTD.
1	21077	Base	Base	Base	MDP	664	508	12	1
2	21078	Rodapé frontal	Front footer	Pie de página frontal	MDP	1896	88	12	1
3	21079	Rodapé traseiro	Rear footer	Pie de página trasero	MDP	1896	88	12	1
4	21080	Trava do rodapé	Footer latch	Pestillo de pie de página	MDP	485	88	12	2
5	21081	Divisória da gaveta esquerda	Left drawer partition	Partición del cajón izquierdo	MDP	581	510	12	1
6	21082	Divisória da gaveta direita	Right drawer partition	Partición del cajón derecho	MDP	581	510	12	1
7	21083	Prateleira móvel	Mobile shelf	Estante móvil	MDP	664	385	12	1
8	21084	Trava central do tampo	Central lid lock	Bloqueo de tapa central	MDP	664	44	12	1
9	21085	Lateral esquerda	Left-back	Lateral izquierdo	MDP	2180	510	12	1
10	21086	Trava do tampo	Top lock	Bloqueo superior	MDP	604	44	12	2
11	21087	Lateral direita	Right side	Lado derecho	MDP	2180	510	12	1
12	21088	Tampo gaveteiro	Chest of drawers	Cajonera	MDP	1896	510	12	1
13	21089	Divisória	Partition	Dividir	MDP	1080	385	12	2
14	21090	Prateleira superior	Top shelf	Estante superior	MDP	624	385	12	2
15	21091	Base do maleiro	Mallet base	Base de mazo	MDP	1896	385	12	1
16	21092	Batente superior	Top stop	Parada superior	MDP	375	88	12	2
17	21093	Chapéu	Hat	Sombrero	MDP	1896	510	12	1
18	21094	Vista frontal	Front view	Vista frontal	MDP	1920	88	15	1
19	21095	Porta	Door	Puerta	MDP	591	334	15	2
20	21096	Frente gaveta	Drawer front	Frente de cajón	MDP	612	195	15	6
21	21097	Lateral gaveta	Side drawer	Cajón lateral	MDP	350	100	12	12
22	21098	Contra fundo	Against background	Contra el fondo	MDP	555	88	12	6
23	21099	Fundo gaveta	Drawer bottom	Fondo de cajón	HDF	577	355	3	6
24	21100	Porta correr	Sliding door	Puerta corredera	MDP	1439	598	15	2
25	21101	Vista da porta	View from the door	Vista desde la puerta	MDP	1429	72	12	2
26	21102	Porta correr central	Central sliding door	Puerta corredera central	MDP	1439	660	15	1
27	21103	Fundo	Bottom	Fondo	HDF	1916	515	3	4

## INSTRUÇÃO MONTAGEM PRODUTO

Instruccions to Assembly / Instrucciones de montaje



Separar as peças e acessórios de maneira organizada  
Separate parts and accessories in way organized  
Separar las piezas y accesorios de manera organizada



Forrar o chão com o papelão das embalagens.  
Cover the floor with the cardboard  
Cubra el suelo con la embalaje de cartón



É necessário 01 pessoa para montar o produto  
It is necessary one person to assembly  
Es necesario una persona para ensamblar

O produto deve ser a montado por um profissional qualificado  
The product must be assembly by a professional  
El producto debe ser ensamblado por un profesional calificado

Ferramentas necessárias  
(não fornecidas)

Not include tools / No herramientas

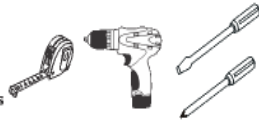

## CUIDADO PARA CONSERVAÇÃO E LIMPEZA DO MÓVEL

Care to conservation and clean / Cuidados de limpieza



O peso máximo de carga informado refere-se a objetos distribuído de maneira uniforme sobre toda área de contato da peça  
Set maximum weight load refers to objects distributed uniformly over the entire contact area of the workpiece.  
Conjunto de carga máxima de peso se refiere a objetos distribuidos uniformemente sobre toda el área de contacto de la pieza de trabajo.



Não molhar o móvel e não expor em lugar úmido  
Do not wet the mobile and do not expose in a wet place  
No moje el producto y no exponer en un lugar húmedo



Não expor o móvel próximo de fontes de calor.  
Do not expose the mobile near heat sources  
no exponga cercano de fuentes de calor



Não usar produtos abrasivos.  
Do not use abrasive products.  
No utilice productos abrasivos.



Limpe com flanela limpa e seca.  
Clean with dry cloth  
Limpieza con un paño limpio y seco

## LISTA DE ACESSÓRIOS E FERRAGEM / ACCESSORIES AND HARDWARE / ACCESORIOS Y EQUIPOS



A - Parafuso 4,5x45 (38x)  
screw / tornillo



B- Parafuso 3,5x25 (32x)  
screw / tornillo



C- Parafuso 3,5x22 (08x)  
screw / tornillo



D- Parafuso 4,0x16 (04x)  
screw / tornillo

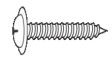

E- Parafuso 4,0x12 (16x)  
screw / tornillo



F- Parafuso 3,5x12 (133x)  
screw / tornillo



G- Parafuso 3,0x12 (60x)  
screw / tornillo



H- Cavilha 6x30 (40x)  
peg / cerrojo



I- Prego (180x)  
nail / clavo



J- Porca cilíndrica (12x)  
CylindricalNut/Tuerca cilíndrica



K- Parafuso minifix (18x)  
Minifix screw / Tornillo minifix



L- Tambor Minifix (18x)  
Minifix Drum / Tambor minifix



M- Dobradiça (04x)  
hinge / bisagra



N- Puxador (08x)  
handle / manija

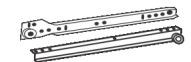

O - Corrediça (06x)  
runners / corredera



P-Suporte cabide (04X)  
hook support / soporte gancho



Q - Cabideiro Alumínio (02x)  
Coat Rack / Perchero



R - Suporte prateleira(04x)  
Support/apoyo



S- Perfil H (03x)  
Frame / Perfil



T - Pés de ropeiro (8x)  
wardrobe feet / pies guardarropa

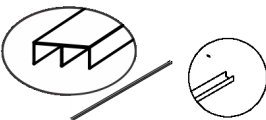

U - Trilho superior (01x)  
top rail / carril superior

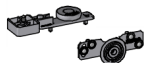

V- Kit porta correr (03x)  
bearing kit / kit de rodamientos



W- Cantoneira (18x)  
corner / esquina

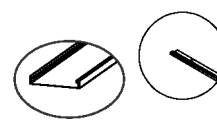

Y - Trilho inferior duplo (01x)  
Bottom rail / Riel inferior



Z- Tapa furo minifix (48x)  
minifix cover / tapa minifix



AA- Cavilha 6x60 (02x)  
peg / cerrojo

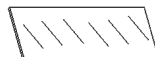

AB - ESPELHO 580 X 425 (02x)  
MIRROR / MIRROR



AC - Gota Silicone (10x)  
wood support / Bastón



AD - SACHE cola 20g (1x)  
Glue / Goma

01° PASSO Fixar peça 1 nas peças 2 e 3

01° STEP Fix part 1 to parts 2 and 3

01° PASO Fije la parte 1 a las partes 2 y 3

A

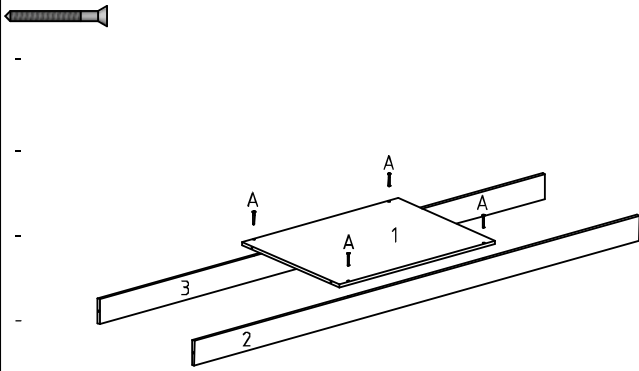

02° PASSO Fixar peças 4 na peça 1. Fixar acessorio ( T ) nas peças 2,3 e 4

02° STEP Fix parts 4 to part 1. Fix accessory ( T ) to parts 2,3 and 4

02° PASO Fije las piezas 4 a la pieza 1. Fije el accesorio ( T ) a las piezas 2,3 y 4

F

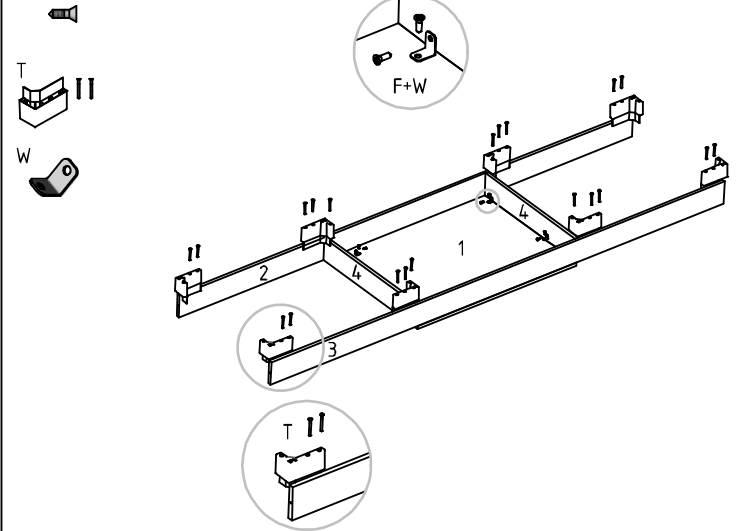

03° PASSO Fixar peça 8 nas peças 5 e 6 . Fixar peças 5 e 6 na peça 1

03° STEP Fix part 8 to parts 5 and 6. Fix parts 5 and 6 to part 1

03° PASO Fije la pieza 8 a las piezas 5 y 6. Fije las partes 5 y 6 a la parte 1

A

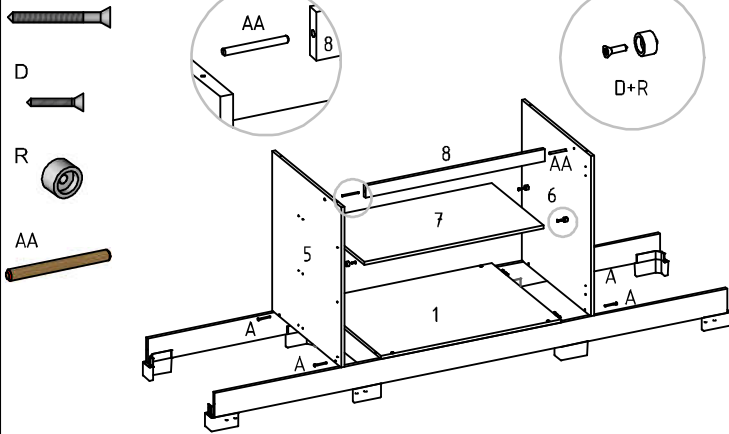

04° PASSO Fixar peças 9 e 11 nas peças 2,3 e 10

04° STEP Fix parts 9 and 11 to parts 2,3 and 10

04° PASO Fije las partes 9 y 11 a las partes 2, 3 y 10

A

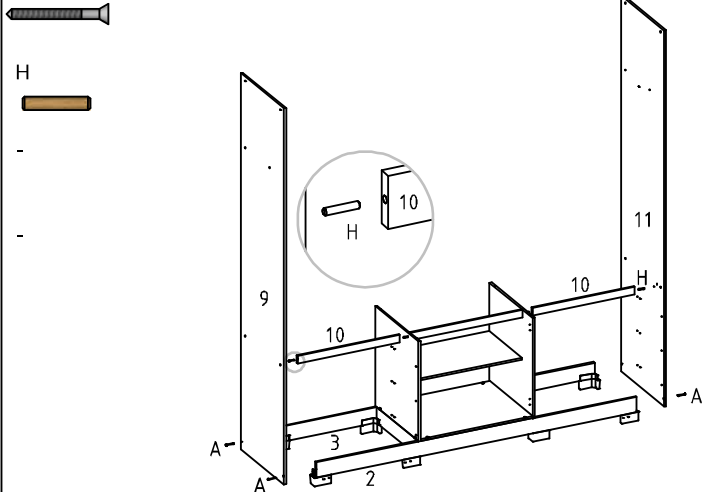

05° PASSO Fixar peça 12 nas peças 5,6,9 e 11

05° STEP Fix part 12 to parts 5,6,9 and 11

05° PASO Fije la pieza 12 a las piezas 5, 6, 9 y 11

A

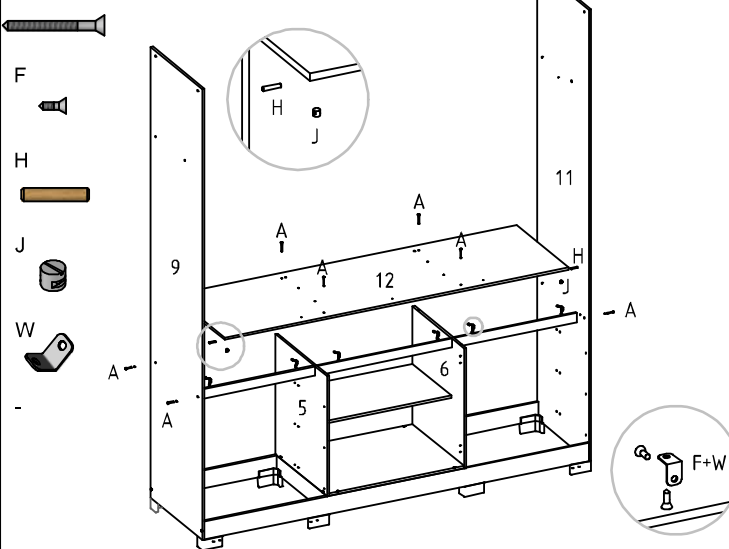

06° PASSO Fixar peças 14 na peça 13 . Fixar peças 13 na peça 12

06° STEP Fix parts 14 to part 13. Fix parts 13 to part 12

06° PASO Fije las partes 14 a la parte 13. Fije las partes 13 a la parte 12

A

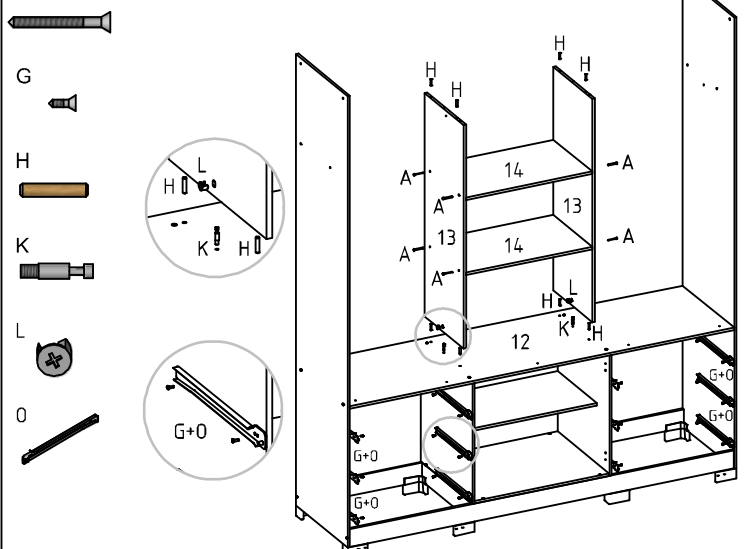

07° PASSO Fixar peças 16 nas peças 15 e 17 Fixar peças 15 e 17 nas peças 9, 11 e 13

07° STEP Fix parts 16 to parts 15 and 17 Fix parts 15 and 17 to parts 9, 11 and 13

07° PASO Fije las piezas 16 a las piezas 15 y 17 Fije las piezas 15 y 17 a las piezas 9, 11 y 13

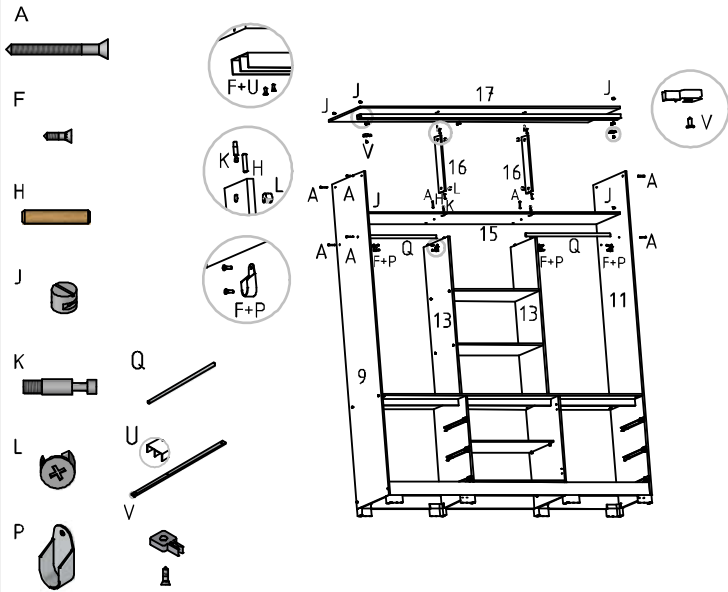

08° PASSO Fixar peça 18 utilizando acessório (F+W) Fixar peças 27 utilizando os acessórios (I + S)

08° STEP Fix part 18 using accessories (F + W) Fix parts 27 using accessories (I + S)

08° PASO Fije la pieza 18 con accesorios (F + W) Fije la pieza 27 con accesorios (I + S)

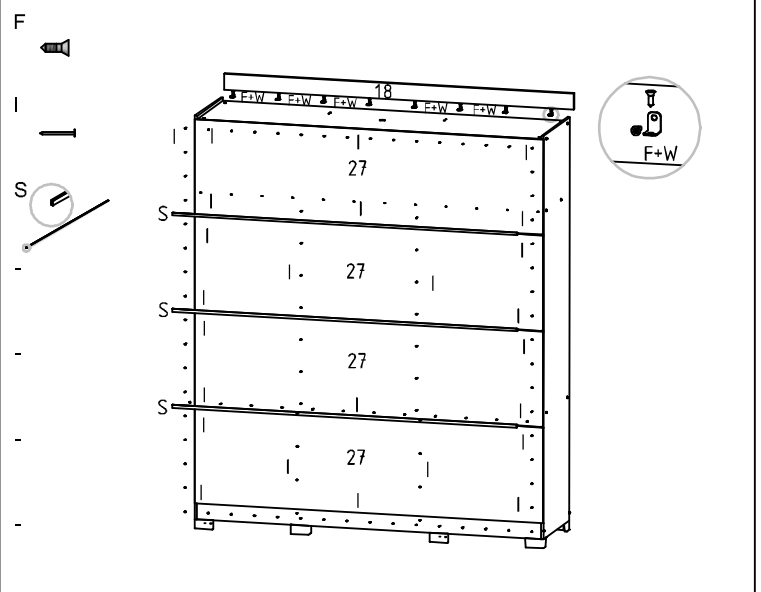

09° PASSO Fixar peças 21 nas peças 20 e 22 . Fixar peça 23 nas peças 21 e 22

09° STEP Fix parts 21 to parts 20 and 22. Fix part 23 to parts 21 and 22

09° PASO Fije las partes 21 a las partes 20 y 22. Fije la pieza 23 a las piezas 21 y 22

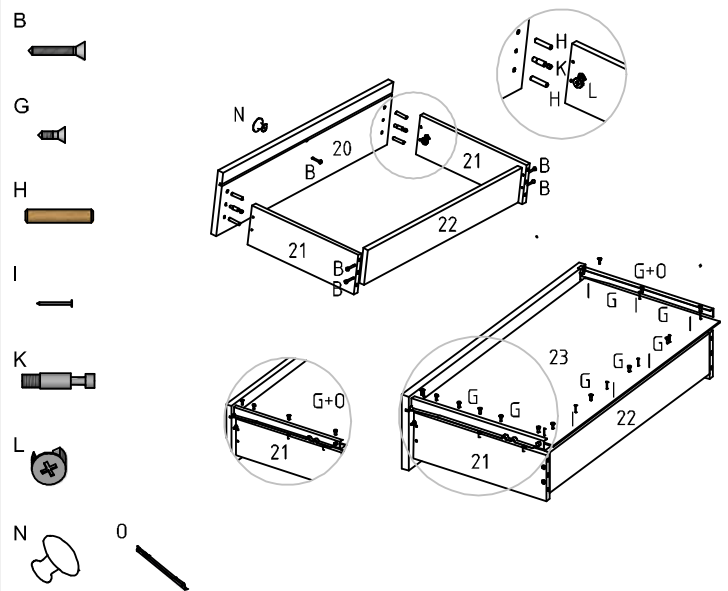

10° PASSO Fixar acessórios ( V ) nas peças 24 e 26

10° STEP Fix accessories (V) on parts 24 and 26

10° PASO Fije los accesorios (V) en las partes 24 y 26

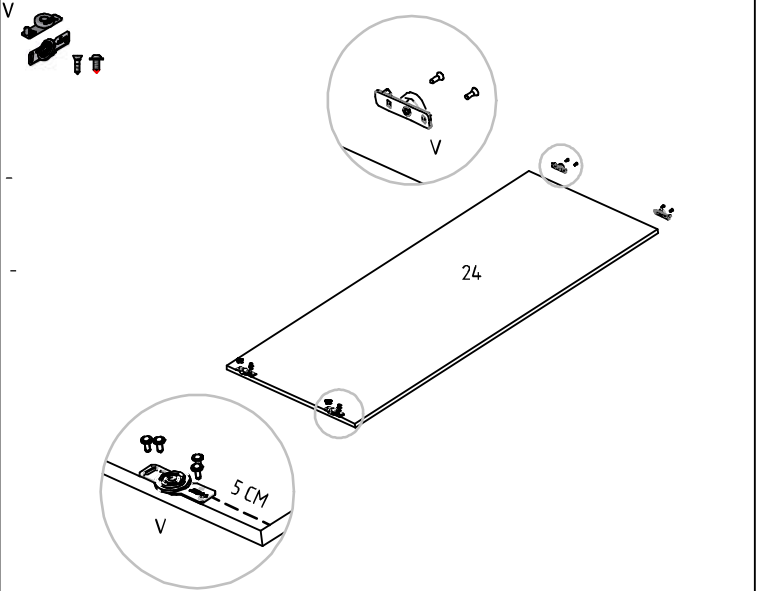

11° PASSO Fixar peça 25 na parte inferior da peça 24 . Deixar a peça 25 com 3 cm de pega

11° STEP Fix parts 19 to parts 5 and 6. Fit drawers and sliding doors to the product

11° PASO Fije las partes 19 a las partes 5 y 6. Montar cajones y puertas correderas al producto

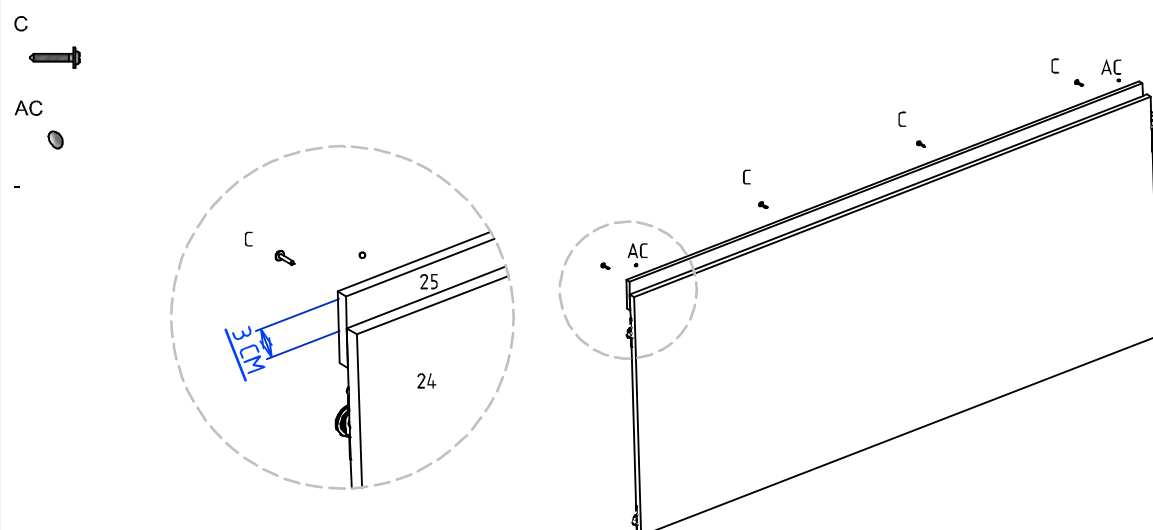

07° PASSO Fazer as colagem dos espelhos na peça 26

07° STEP Make the mirrors glue on part 26

07° PASO Haz que los espejos se peguen en la parte 26

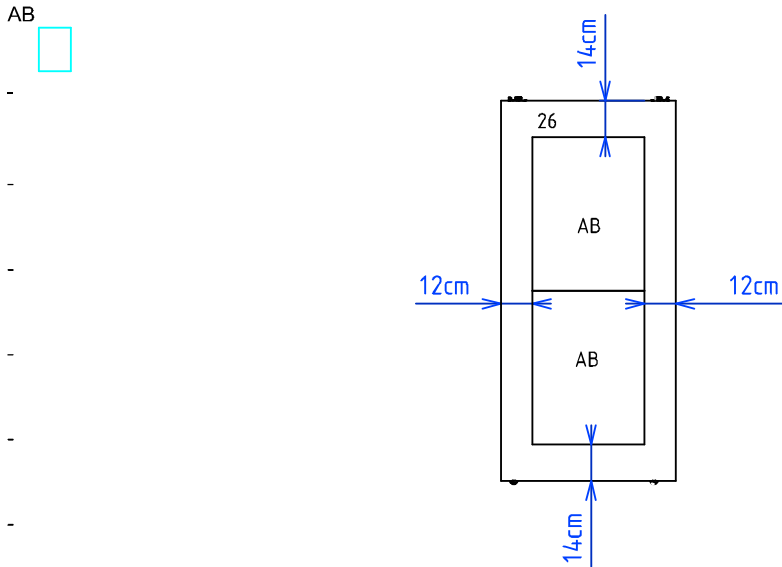

09° PASSO Fixar peças 19 nas peças 5 e 6 . Encaixar gavetas e portas de correr no produto

09° STEP Fix parts 19 to parts 5 and 6. Fit drawers and sliding doors to the product

09° PASO Fije las partes 19 a las partes 5 y 6. Montar cajones y puertas correderas al producto

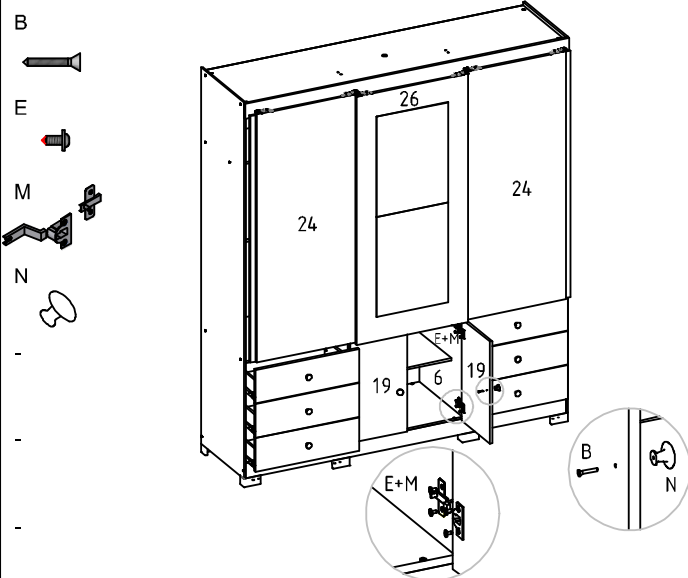

10° PASSO Aspecto final do produto

10° STEP Final product aspect

10° PASO Aspecto final del producto

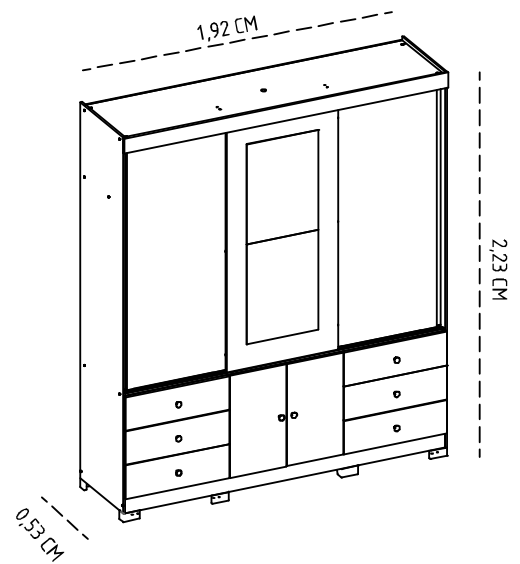

11° PASSO -

11° STEP -

11° PASO -

12° PASSO -

12° STEP -

12° PASO -