

**2130 - CAMARIM STUDIO**

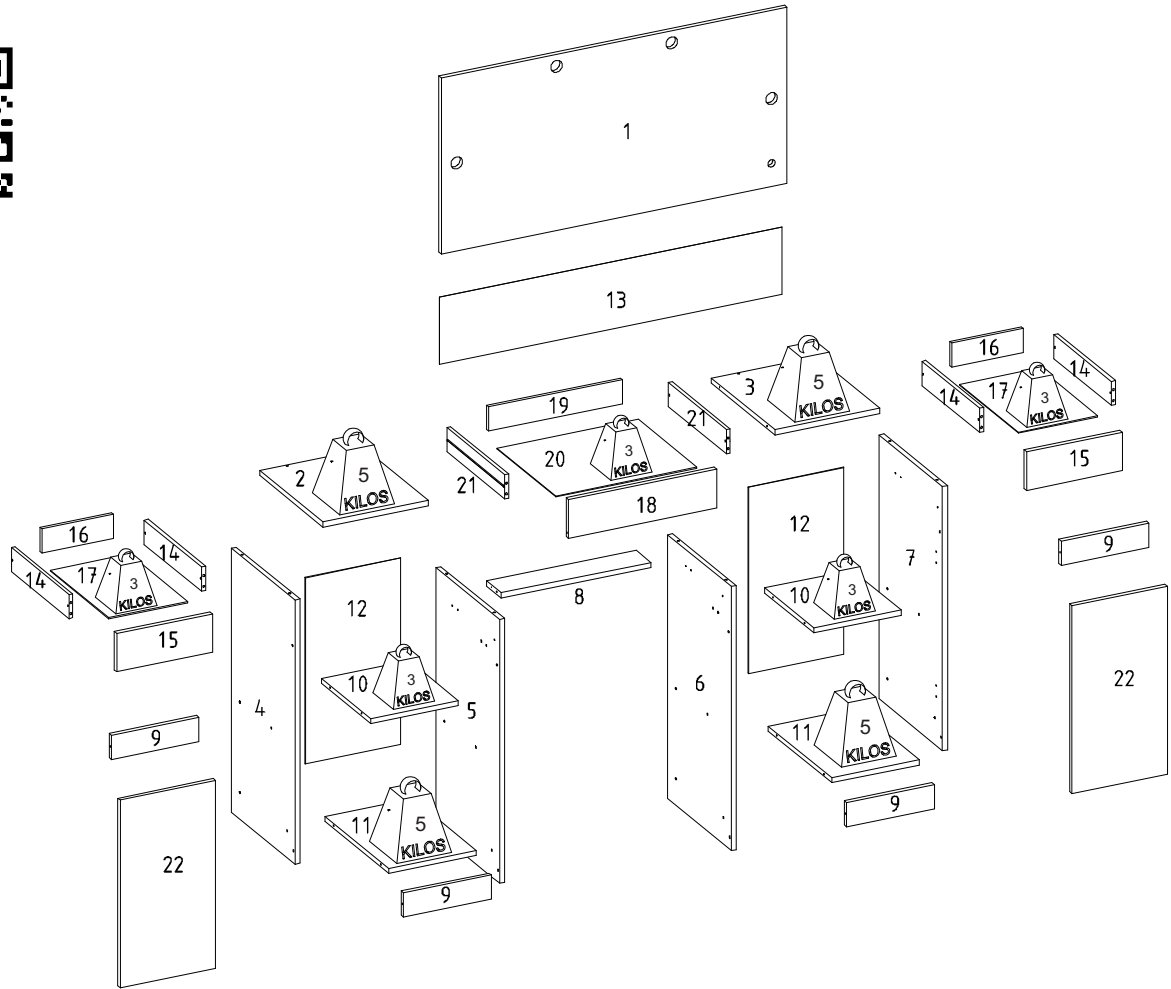

**LISTA DE PEÇAS / Pieces List / Lista de Piezas**

SEQ.	REF.	DESCRIÇÃO	DESCRIPTION	DESCRIPCIÓN	MAT.PRIMA	COMP.	LARG.	ESP.	QTD.
1	321503	Painel	Panel	Panel	MDP	1050	525	15	1
2	321504	Tampo esquerdo	Left top	Arriba a la izquierda	MDP	385	320	15	1
3	321505	Tampo direito	Right top	Justo arriba	MDP	385	320	15	1
4	321506	Lateral esquerda	Left-back	Lateral izquierdo	MDP	785	385	15	1
5	321507	Divisória esquerda	Left partition	Partición izquierda	MDP	785	385	15	1
6	321508	Divisória direita	Right partition	Partición derecha	MDP	785	385	15	1
7	321509	Lateral direita	Right side	Lado derecho	MDP	785	385	15	1
8	321510	Vista central	Central view	Vista central	MDP	454	88	15	1
9	321511	Vista frontal	Front view	Vista frontal	MDP	266	72	15	4
10	321512	Prateleira	Shelf	Estante	MDP	266	298	15	2
11	321513	Base	Base	Base	MDP	385	266	15	2
12	321514	Fundo	Bottom	Fondo	HDF	554	290	3	2
13	321515	Fundo central	Central bottom	Fondo central	HDF	1040	200	3	1
14	700601	Lateral de gaveta	Drawer side	Lado del cajón	MDP	350	72	12	4
15	321517	Frente da gaveta menor	Smaller drawer front	Frente de cajón más pequeño	MDP	290	115	15	2
16	321518	Contra fundo menor	Against a smaller background	Contra un fondo más pequeño	MDP	217	72	12	2
17	321519	Fundo da gaveta menor	Smaller drawer bottom	Fondo de cajón más pequeño	HDF	241	355	3	2
18	321520	Frente de gaveta central	Drawer front	Frente de cajón	MDP	450	115	15	1
19	321521	Contra fundo central	Against background	Contra el fondo	MDP	405	72	12	1
20	321522	Fundo da gaveta central	Drawer bottom	Fondo de cajón	HDF	429	355	3	1
21	321523	Lateral de gaveta central	Central drawer side	Lateral del cajón central	MDP	350	72	12	2
22	321524	Porta	Door	Puerta	MDP	558	290	15	2

**INSTRUÇÃO MONTAGEM PRODUTO**  
 Instructions to Assembly / Instrucciones de montaje

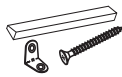

Separe as peças e acessórios de maneira organizada  
 Separate parts and accessories in way organized  
 Separe las piezas y accesorios de manera organizada

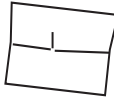

Forrar o chão com o papelão das embalagens.  
 Cover the floor with the cardboard  
 Cubra el suelo con la embalaje de cartón



É necessário 02 pessoas para montar o produto  
 02 people are required to assemble the product  
 Se requieren 02 personas para ensamblar el producto

O produto deve ser a montado por um profissional qualificado  
 The product must be assembly by a professional  
 El producto debe ser ensamblado por un profesional calificado

Ferramentas necessárias  
 (não fornecidas)

Not include tools / No herramientas



**CUIDADO PARA CONSERVAÇÃO E LIMPEZA DO MÓVEL**  
 Care to conservation and clean / Cuidados de limpieza

Peso máximo de carga informado refere-se a objetos distribuido de maneira uniforme sobre toda área de contato da peça



The maximum load weight informed refers to objects distributed evenly over the entire contact area of the part  
 Conjunto de carga máxima de peso se refiere a objetos distribuidos uniformemente sobre toda el área de contacto de la pieza de trabajo.



Não molhar o móvel e não expor em lugar úmido  
 Do not wet the mobile and do not expose in a wet place  
 No moje el producto y no exponer en un lugar húmedo



Não expor o móvel próximo de fontes de calor.  
 Do not expose the mobile near heat sources  
 no exponga cercano de fuentes de calor



Não usar produtos abrasivos.  
 Do not use abrasive products.  
 No utilice productos abrasivos.



Limpe com flanela limpa e seca.  
 Clean with dry cloth  
 Limpieza con un paño limpio y seco

**LISTA DE ACESSÓRIOS E FERRAGENS / ACCESSORIES AND HARDWARE / ACCESORIOS Y HARDWARE**



A - 700137-Parafuso 4,5x45 (32x)  
 screw / tornillo



B- 700124-Parafuso 3,5x25 (12x)  
 screw / tornillo

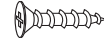

C- 700120-Parafuso 3,0x12 (102x)  
 screw / tornillo



D- 700127-Parafuso 4,0x12 (40x)  
 screw / tornillo



E- 700600-kit luminaria(1x)  
 light kit / kit de luz



F- 700556-Suporte de vidro (4x)  
 glass support / soporte de vidrio



G- 700448-Sapata 'L' (8x)  
 shoe / zapata



H - 700111-Corrediça metálica (2x)  
 runners / corredera



I- 700542-Cavilha 6x30 (20x)  
 peg / cerrojo



J- 700539-Cantoneira (12x)  
 corner / esquina

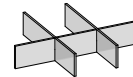

K- 700606-Divisor joias(1x)  
 jewelry divider /  
 divisor de joyas



L- 700605-Vidro (1x)  
 glass / vaso



M- 700396-Dobradiça (4x)  
 700389-Calço(4x)  
 hinge / bisagra



N- 700598-Espelho(1x)  
 mirror / espejo



O - 700516-Sache cola 20g (1x)  
 Glue / Goma



P- 700157-Prego (58x)  
 nail / clavo



Q- 700602-Perfil H (2x)  
 handle / manija



R- 701157-Suporte triangular (6x)  
 Triangular support / Soporte triangular



S - 700113-Corrediça (1x)  
 runners / corredera



O- 700419-Tapa furo (24x)  
 Cover hole / agujero de la cubierta

01° PASSO Fixar peças 2 e 3 na peça 1

01° STEP Fix parts 2 and 3 to part 1

01° PASO Fije las partes 2 y 3 a la parte 1

A

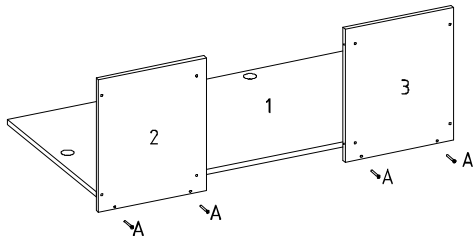

02° PASSO Fixar peças 4 e 5 na peça 2, fixar peças 6 e 7 na peça 3

02° STEP Fix parts 4 and 5 to part 2, fix parts 6 and 7 to part 3

02° PASO Fije las partes 4 y 5 a la parte 2, fije las partes 6 y 7 a la parte 3

C



G



I



J

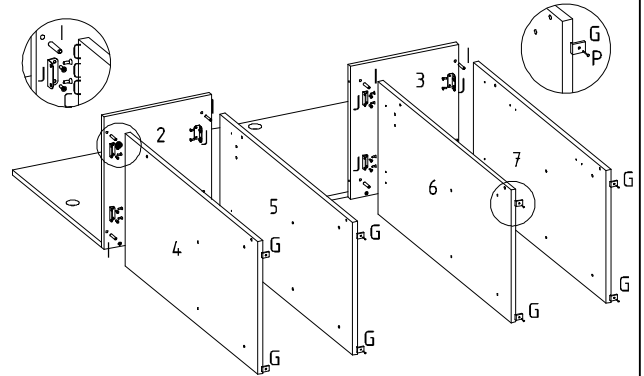

03° PASSO Fixar peça 8 nas peças 5 e 6

03° STEP Fix part 8 to parts 5 and 6

03° PASO Fije la parte 8 a las partes 5 y 6

A

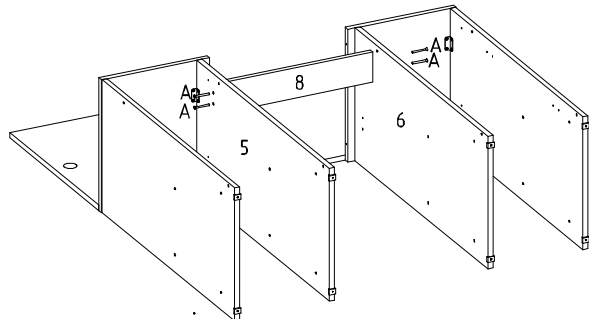

04° PASSO Fixar acessórios indicados

04° STEP Fix indicated accessories

04° PASO Arregle los accesorios indicados

C



H



S

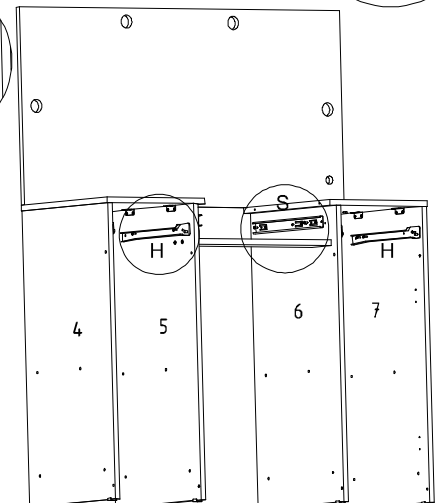
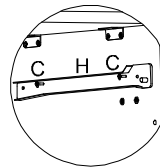

05° PASSO Fixar peças 09, 10 e 11 nas peças 4 e 5, 6 e 7

05° STEP Fix parts 09, 10 and 11 to parts 4 and 5, 6 and 7

05° PASO Fije las partes 09, 10 y 11 a las partes 4 y 5, 6 y 7

A



C



J

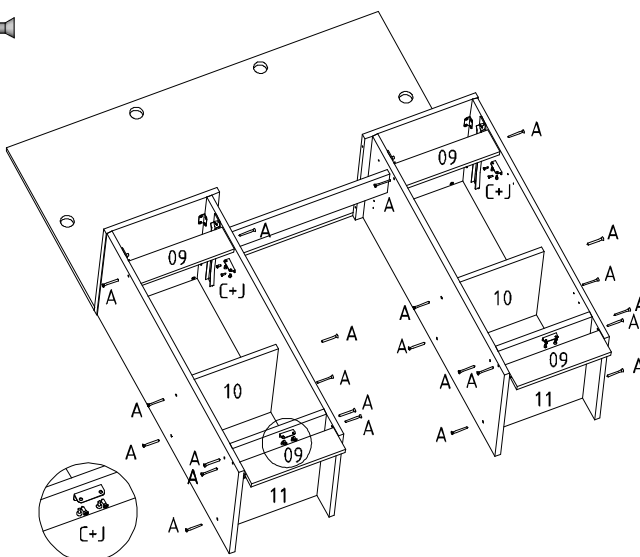

06° PASSO Fixar 12 e 13 conforme indicado

06° STEP Fix 12 and 13 as indicated

06° PASO Arregle 12 y 13 como se indica

C



P



Q

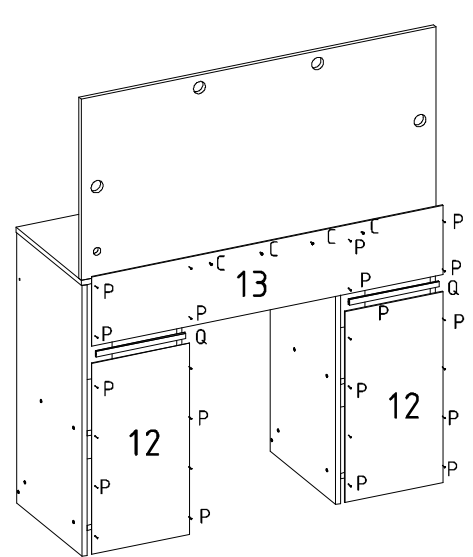

07° PASSO Fixar peça 22 conforme indicado

07° STEP Fije la pieza 22 como se indica

07° PASO Fix part 22 as indicated

D



M

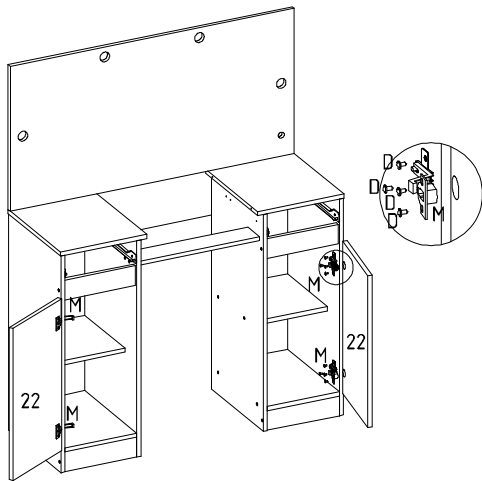

08° PASSO Fixar acessórios como indicado

08° STEP Attach accessories as indicated

08° PASO Coloque los accesorios como se indica

C



E



F



L



N

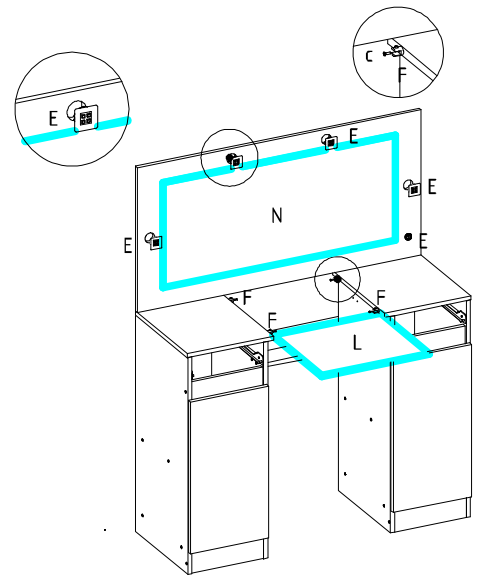

09° PASSO Fixar peça 21 nas peças 18 e 19, fixar peça 20 como indicado

09° STEP Fix part 21 to parts 18 and 19, fix part 20 as shown

09° PASO Fije la pieza 21 a las piezas 18 y 19, fije la pieza 20 como se muestra

B



D



I



P



R



S

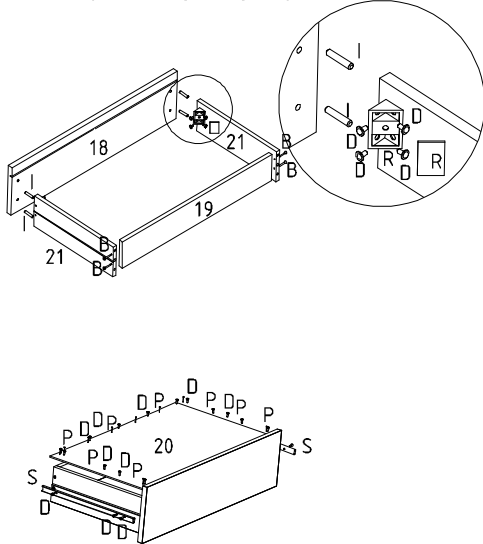

10° PASSO Fixar peça 14 nas peças 15 e 16, fixar peça 17 como indicado

10° STEP Fix part 14 to parts 15 and 16, fix part 17 as shown

10° PASO Fije la pieza 14 a las piezas 15 y 16, fije la pieza 17 como se muestra

B



D



H



I



P



R

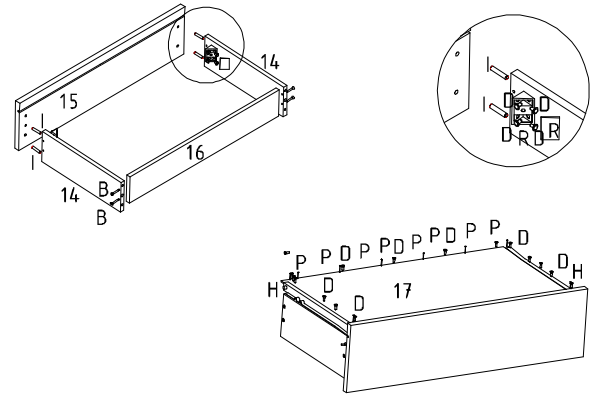

11° PASSO Fazer colocação das gavetas e do acessório K

11° STEP Place the drawers and accessories K

11° PASO Coloca los cajones y accesorios K

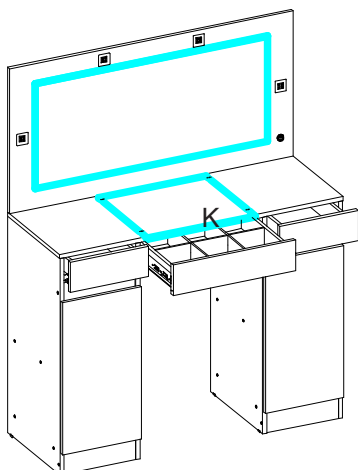

12° PASSO Aspecto final do produto

12° STEP Final product aspect

12° PASO Aspecto final del producto

