

MÖBLER

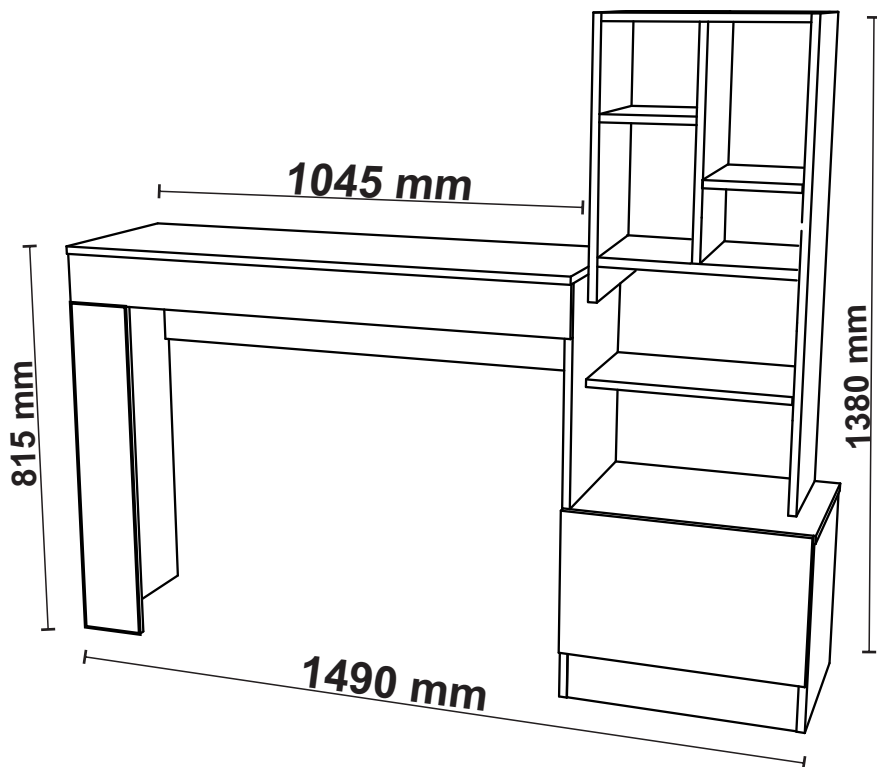

3003030 - ESC. BIBLIOTECA LION

511 - BRANCO FOSCO / 727 - TECA SUPREMO



1 hora.

Para montagem:

For mounting / Para el montaje:

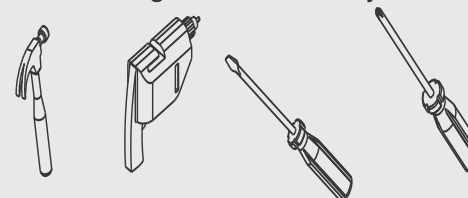

LEGENDA DE CORES

511 - BRANCO FOSCO

727 - TECA SUPREMO

Ficha técnica

3003030 - ESC. BIBLIOTECA LION

Nº	DESCRIÇÃO	CORES		Mat. Prima	MEDIDAS (mm)	Qtd.
		BRANCO FOSCO	TECA SUPREMO			
01	FUNDO SUP.	511	727	MDP MöB PRINT	0575 X 196 X 03	02
02	FUNDO CENTRAL	511	727	MDP MöB PRINT	0410 X 250 X 03	01
03	FUNDO MENOR	511	727	MDP MöB PRINT	0410 X 182 X 03	01
04	FUNDO GAV.	511	727	MDP MöB PRINT	0409 X 305 X 03	01
05	FUNDO INF.	511	727	MDP MöB PRINT	0460 X 260 X 03	01
21	LAT. ESQ.	511	727	MDP MöB PRINT	0800 X 340 X 15	01
22	TAMPO	511	727	MDP MöB PRINT	1045 X 360 X 15	01
23	LAT. DIR. TAMPO	511	727	MDP MöB PRINT	0800 X 340 X 15	01
24	VISTA TAMPO	511	727	MDP MöB PRINT	1045 X 100 X 15	01
25	VISTA LAT. TAMPO	511	727	MDP MöB PRINT	0700 X 100 X 15	01
26	TAMPO GAV.	511	727	MDP MöB PRINT	0450 X 340 X 15	01
27	LAT. DIR. GAV.	511	727	MDP MöB PRINT	0360 X 340 X 15	01
28	RODAPÉ	511	727	MDP MöB PRINT	0433 X 100 X 15	01
29	LAT. DIR. SUP.	511	727	MDP MöB PRINT	1000 X 240 X 15	01
30	LAT. ESQ. NICHÓ	511	727	MDP MöB PRINT	0640 X 240 X 15	01
31	PRAT. / CHAPÉU	511	727	MDP MöB PRINT	0371 X 240 X 15	02
33	DIV. NICHÓ	511	727	MDP MöB PRINT	0525 X 240 X 15	01
34	PRAT. NICHÓ	511	727	MDP MöB PRINT	0240 X 178 X 15	02
35	PRATELEIRA	511	727	MDP MöB PRINT	0386 X 240 X 15	01
36	FRENTE GAV.	511	727	MDP MöB PRINT	0459 X 280 X 15	01
37	TRAVESSA TAMPO	511	727	MDP MöB PRINT	1010 X 240 X 15	01
38	BASE	511	727	MDP MöB PRINT	0433 X 340 X 15	01
39	LAT. GAV.	511	727	MDP MöB PRINT	0300 X 150 X 15	02
40	CONTRA FUNDO	511	727	MDP MöB PRINT	0379 X 150 X 15	01

Parabens você acaba de adquirir um produto MOBLER. Você tem a sua disposição que há de melhor em qualidade e design.

Congratulations you have just purchased a Möbler product. You have at your disposal the best in quality and design. Felicitaciones, acaba de comprar un producto Möbler. Tienes a tu disposición lo mejor en calidad y diseño.

Rua Floresta, Nº 08 - Jardim Santa Terezinha - Fone (0**43) 3242 - 8800 - Bela Vista do Paraíso - Paraná - www.mobler.ind.br

DESCRIÇÃO DE ACESSÓRIOS







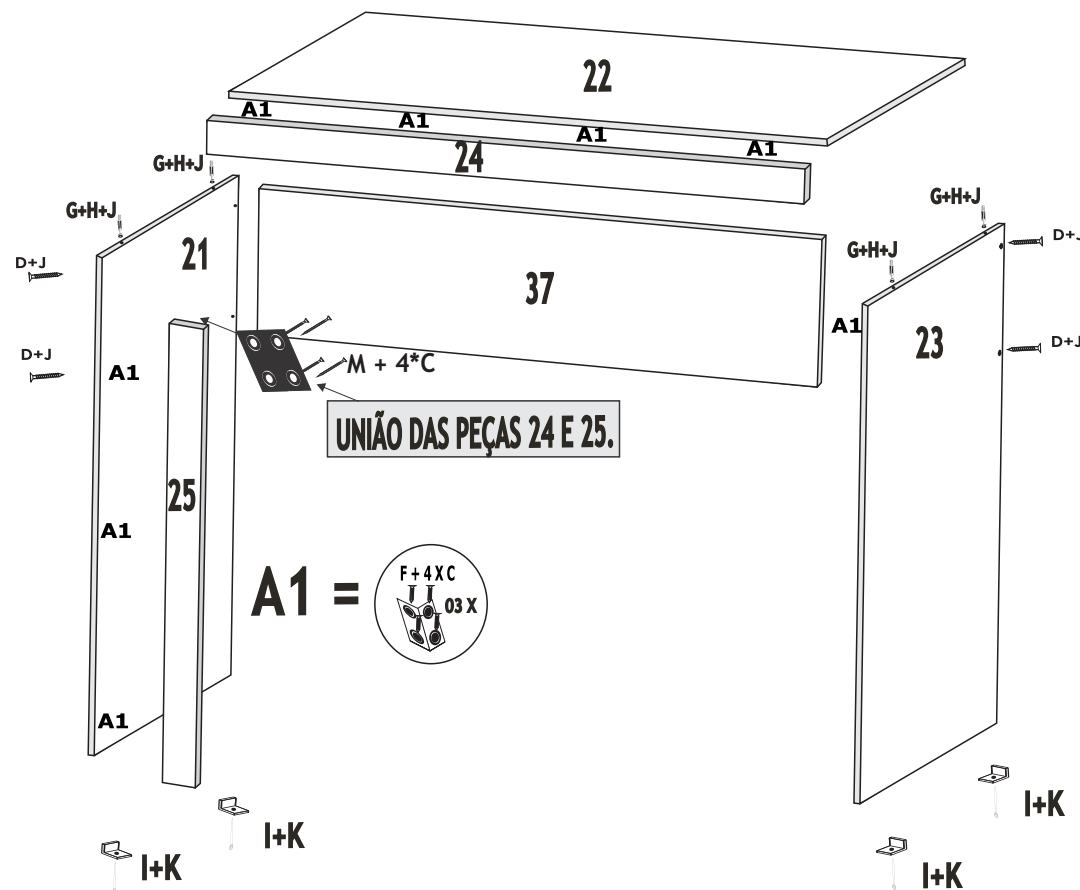

Cód.	DESCRIÇÃO	Qt.	DESENHO
A	SACHÊ DE COLA COLA GLUE	01	
B	CANTONEIRA DE ZAMAC CANTONERA DE ZAMAC ZAMAC CORNER	04	
C	PARAFUSO 3,5 X 14 mm TORNILLO 3,5*14 SCREW 3,5*14	64	
D	PARAFUSO 3,5 X 40 mm TORNILLO 3,5*40 SCREW 3,5*40	38	
E	CAVILHA 6 X 30 mm BOLSILLO DE MADERA WOODEN POCKET	06	
F	CHAPA L 42 X 42 CANTONERA 4 AGUREJOS 4 HOLES CORNER	11	
G	PINO GIROFIX PIN GIROFIX GIROFIX PIN	06	
H	CASTANHA 15 mm BLOQUEO GIROFIX GIROFIX LOCK	06	
I	SAPATA MINI DESLIZANTE (L) PIES FEET	06	
J	TAMPA DA CASTANHA TAPA DE TAMBOR DRUM COVER	40	
K	PREGO 8 X 8 CLAVO 8*8 NAIL 8*8	48	
L	PREGO 13 X 15 CLAVO 13*15 NAIL 13*15	04	
M	CHAPA 42 X 42 PLACA DE 4 AGUJEROS 4 HOLE PLATE	01	
N	CORREDIÇA TElescÓPICA 300 mm CORREDERA TElescÓPICA TELESCOPIC SLIDE	01	
Q	CHAPINHA DE FUNDO BACKGROUND ANTECEDENTES	10	

1º Passo

C	PARAFUSO 3,5 X 14 mm TORNILLO 3,5*14 SCREW 3,5*14	36		H	CASTANHA 15 mm BLOQUEO GIROFIX GIROFIX LOCK	04	
D	PARAFUSO 3,5 X 40 mm TORNILLO 3,5*40 SCREW 3,5*40	04		I	SAPATA MINI DESLIZANTE (L) PIES FEET	04	
F	CHAPA L 42 X 42 CANTONERA 4 AGUREJOS 4 HOLES CORNER	08		J	TAMPA DA CASTANHA TAPA DE TAMBOR DRUM COVER	08	
G	PINO GIROFIX PIN GIROFIX GIROFIX PIN	04		K	PREGO 8 X 8 CLAVO 8*8 NAIL 8*8	04	
				M	CHAPA 42 X 42	01	







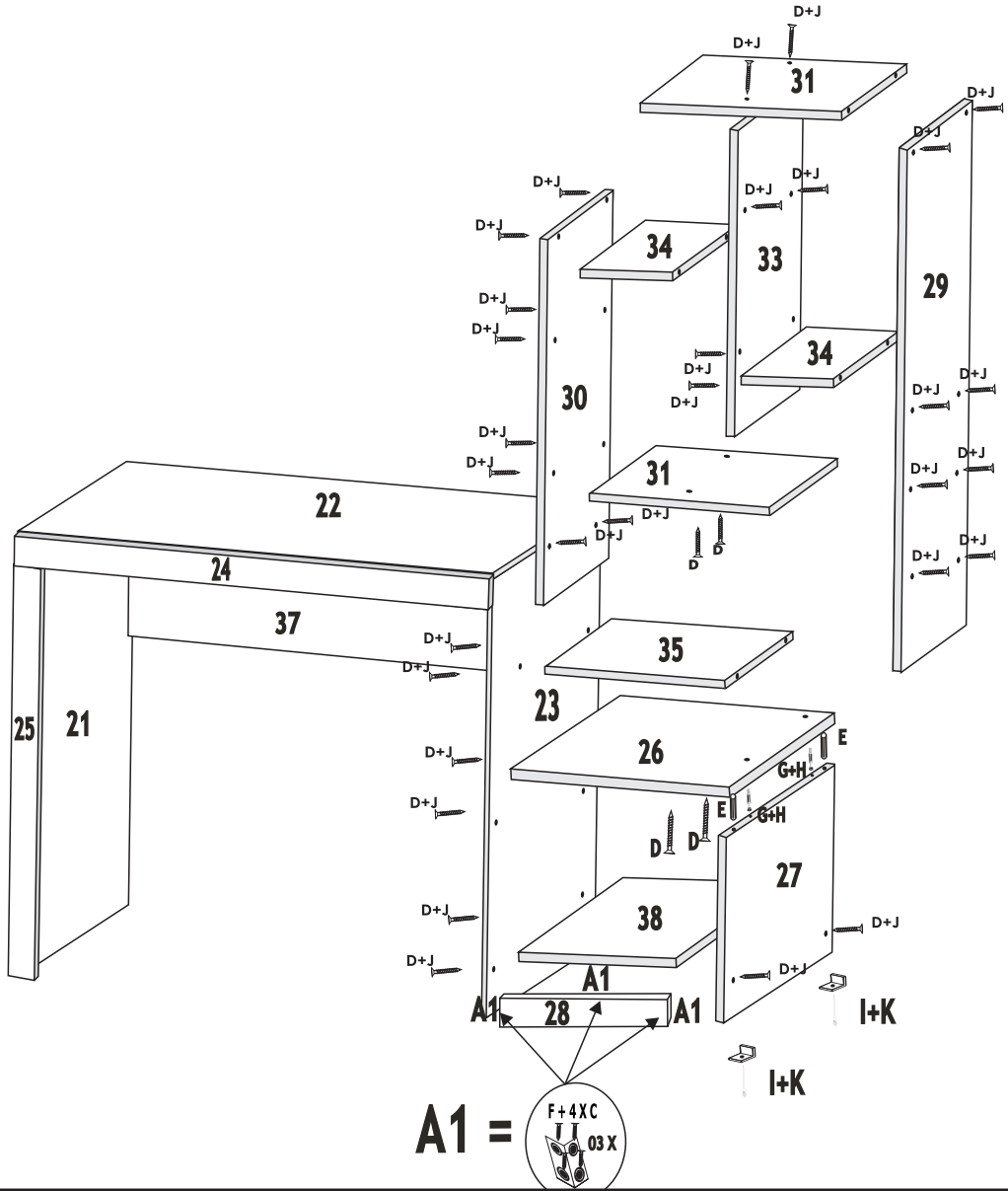

2º Passo

C	PARAFUSO 3,5 X 14 mm TORNILLO 3,5*14 SCREW 3,5*14	12		H	CASTANHA 15 mm BLOQUEIO GIROFIX GIROFIX LOCK	02	
D	PARAFUSO 3,5 X 40 mm TORNILLO 3,5*40 SCREW 3,5*40	34		I	SAPATA MINI DESLIZANTE (L) PIES FEET	02	
F	CHAPA L 42 X 42 CANTONERA 4 AGUREJOS 4 HOLES CORNER	03		J	TAMPA DA CASTANHA TAPA DE TAMBOR DRUM COVER	32	
G	PINO GIROFIX PIN GIROFIX GIROFIX PIN	02		K	PREGO 8 X 8 CLAVO 8*8 NAIL 8*8	02	
				E	CAVILHA 6 X 30 mm BOLSILLO DE MADERA WOODEN POCKET	02	



3º Passo

A	SACHÊ DE COLA COLA GLUE	01		K	PREGO 08 X 08 CLAVO 08*08 NAIL 08*08	10	
B	CANTONEIRA DE ZAMAC CANTONERA DE ZAMAC ZAMAC CORNER	04		L	PREGO 13 X 15 CLAVO 13*15 NAIL 13*15	04	
C	PARAFUSO 3,5 X 14 mm TORNILLO 3,5*14 SCREW 3,5*14	16		N	CORREDEIRA TELESCÓPICA 300 mm CORREDERA TELESCÓPICA TELESCOPIC SLIDE	01	

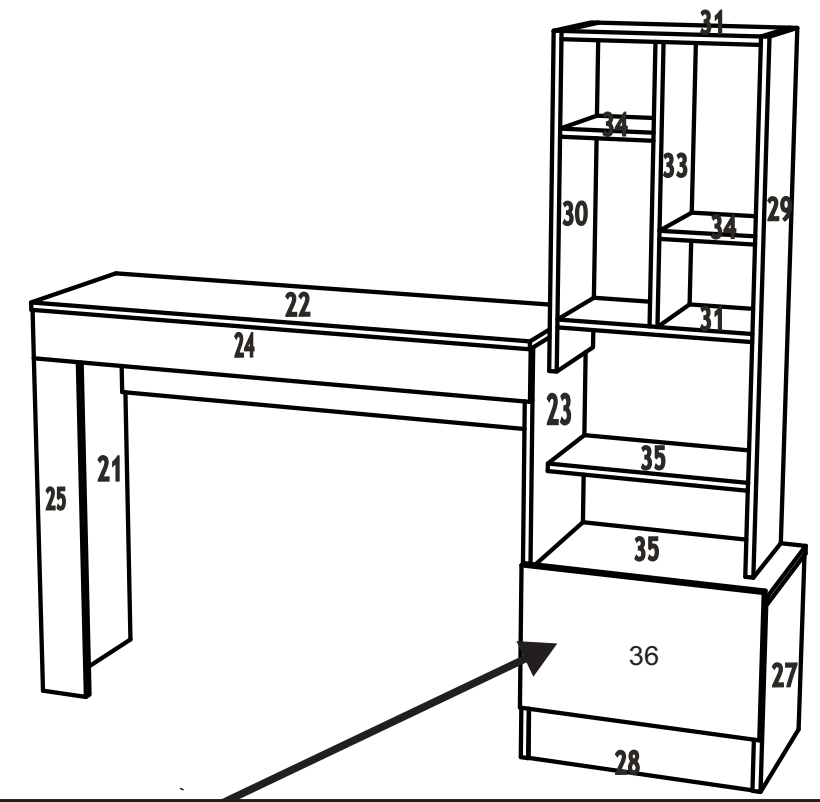

MONTAGEM DA GAVETA

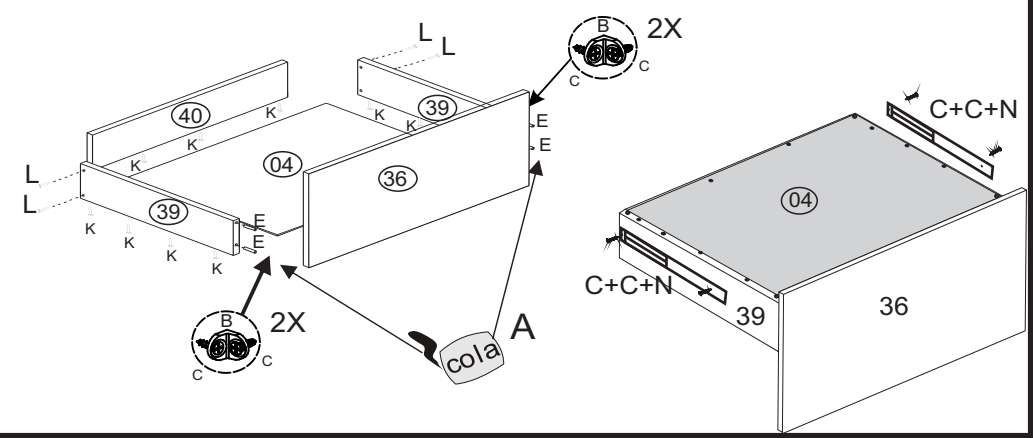

4 ° Passo

Q	CHAPINHA DE FUNDO BACKGROUND / ANTECEDENTES	10	K	PREGO 8 X 8 mm NAIL 8 X 8 mm / CLAVO 8 X 8 mm	32	
---	--	----	---	--	----	--

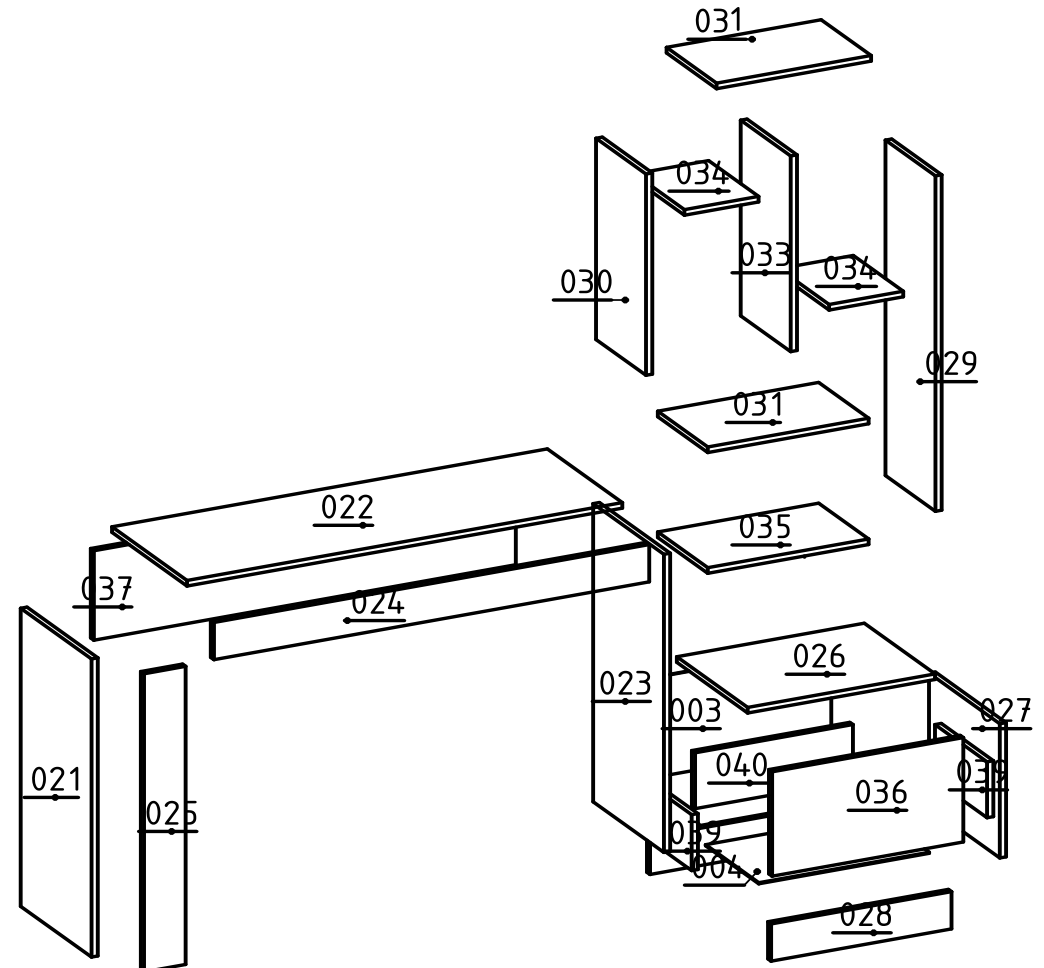
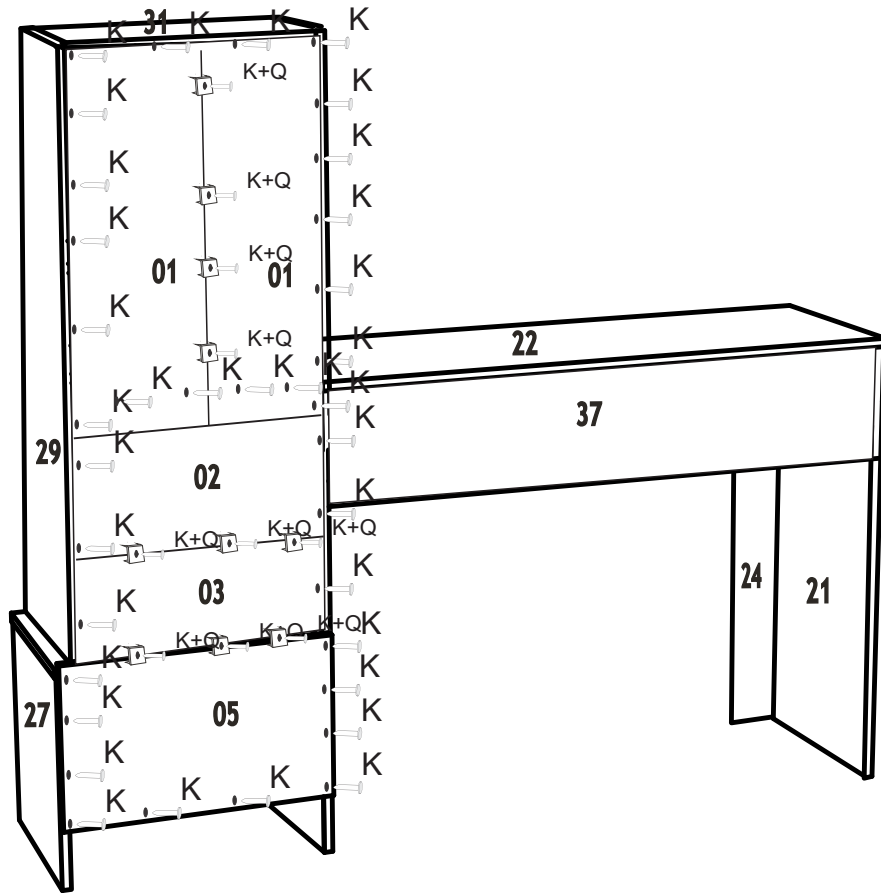

OBSERVAÇÃO LIMPEZA:

A LIMPEZA DO M&B PRINT DEVE SER FEITA COM PANO LEVEMENTE UMEDECIDO COM ÁGUA E DETERGENTE NEUTRO. NUNCA DEVE-SE UTILIZAR PRODUTOS ABRASIVOS E PRODUTOS QUÍMICOS. OS PRINCIPAIS AGENTES MANCHADORES DO M&B PRINT SÃO: ACETONA, ÁLCOOL, ETÍLICO, MOSTARDA, DETERGENTE, DESINFETANTE, ÁGUA, CAFÉ SOLÚVEL, LEITE EM PÓ INTEGRAL, ÁCIDO ACÉTICO, PERÓXIDO DE HIDROGÊNIO, TINTA DE CANETA, TINTA DE PINCEL ATÔMICO, SOLUÇÃO DE AMÔNIA, BATOM VERMELHO, HIDRÓXIDO DE SÓDIO, HIPOCLORITO DE SÓDIO, PVPI, GRAXA DE SAPATO E ÁCIDO CÍTRICO.

LA LIMPIEZA DE LA IMPRESIÓN M&B SE DEBE REALIZAR CON UN COÁGULO DAÑADO CON AGUA Y DETERGENTE NEUTRO. NUNCA USE PRODUCTOS ABRASIVOS NI QUÍMICOS. LOS PRINCIPALES COLORANTES DE M&B PRINT SON: ACETONA, ALCOHOL, ETÍLICO, MOSTAZA, DETERGENTE, DESINFETANTE, AGUA, CAFÉ SOLUBLE, LECHE EN POLVO, ÁCIDO ACÉTICO, PERÓXIDO DE HIDRÓGENO, TINTA DE LÁPIZ, TINTA DE CEPILLO ATÔMICO, SOLUCIÓN DE AMONIACO, LÁPIZ LABIAL ROJO, HIDRÓXIDO DE SODIO, HIPOCLORITO DE SODIO, PVPI, Grasa DE CALZADO Y ÁCIDO CÍTRICO.

CLEANING THE M&B PRINT SHOULD BE CARRIED OUT WITH A CLOT WHICH IS DAMAGED WITH WATER AND NEUTRAL DETERGENT. NEVER USE ABRASIVE PRODUCTS AND CHEMICALS. THE MAIN STAINING AGENTS OF M&B PRINT ARE: ACETONE, ALCOHOL, ETHYLIC, MUSTARD, DETERGENT, DISINFECTANT, WATER, SOLUBLE COFFEE, WHOLE MILK POWDER, ACETIC ACID, HYDROGEN PEROXIDE, PEN INK, ATOMIC BRUSH INK, AMMONIA SOLUTION, RED LIPSTICK, SODIUM HYDROXIDE, SODIUM HYPOCHLORITE, PVPI, SHOE Grease AND CITRIC ACID.