

PRODUTO CONCLUÍDO  
PRODUCTO TERMINADO  
FINISHED PRODUCT

ITM/D344-  
REV. 000

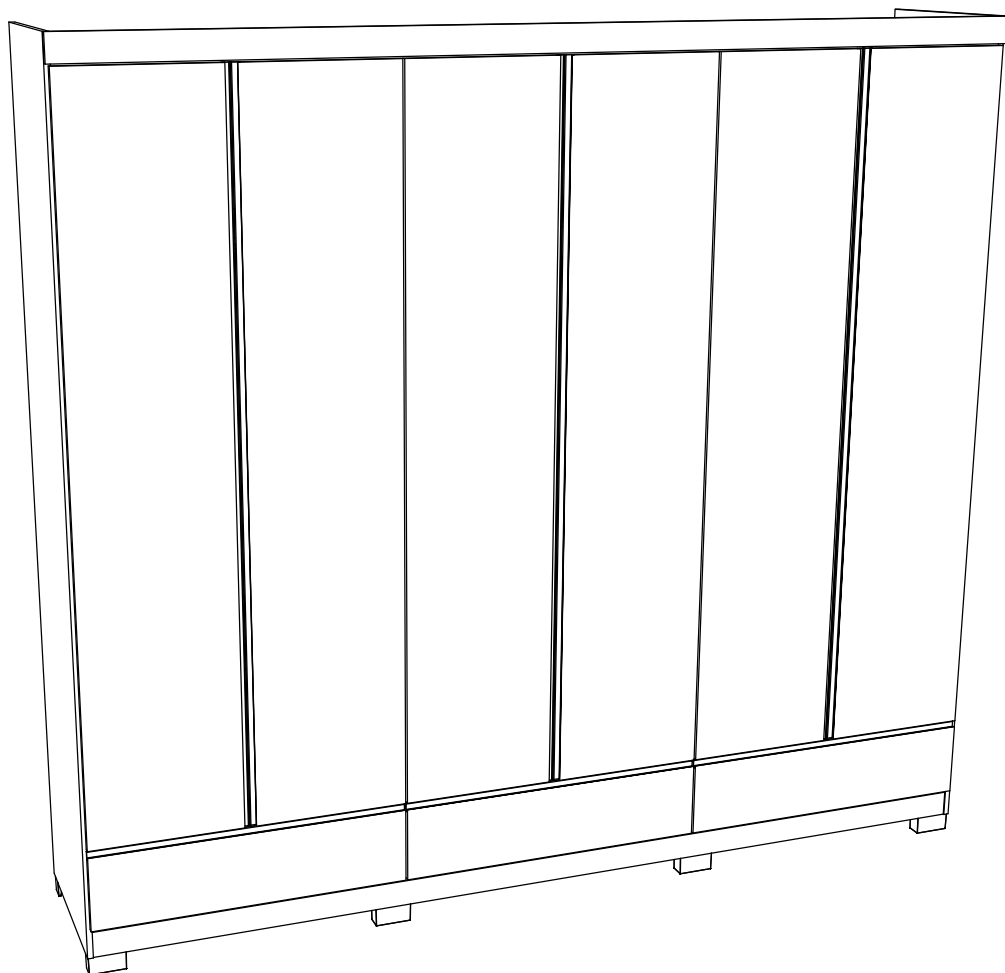

**HENN**

Ind. e Com. de Móveis Henn  
Mondai - SC - Brasil

+55 49 3674.3500

@moveishenn  
www.henn.com.br

ITM/D344-  
**INSTRUÇÕES DE  
MONTAGEM**

INSTRUCCIONES DE MONTAJE  
ASSEMBLY INSTRUCTIONS

**ROUPEIRO IMPERIAL 06 PORTAS 09 GAVETAS |**  
ARMARIO IMPERIAL CON 6 PUERTAS Y 9 CAJONES | IMPERIAL WARDROBE WITH 6 DOORS AND  
9 DRAWERS

D344-214 Cinamomo  
D344-220 Cinamomo/Avelã

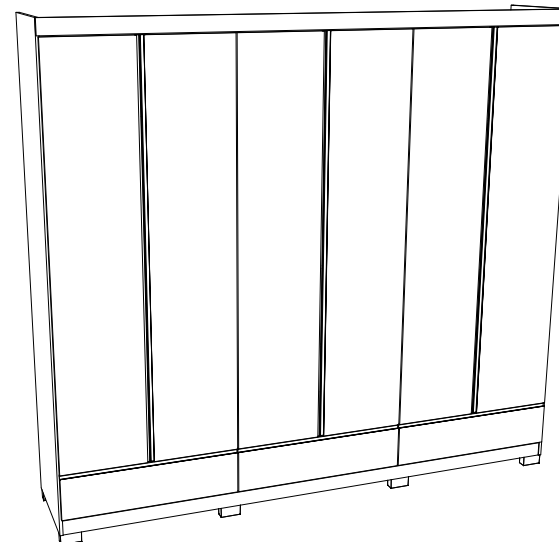

**AVISO**

Para limpeza de seu móvel, use uma flanela seca ou umedecida, e não utilize produtos químicos que possam danificar seu produto.

**SISTEMA DE MONTAGEM**

O sistema de montagem dos produtos, funciona de acordo com a ordem crescente dos números indicados no desenho. Ex: 01, 02, 03, 04... até a conclusão da montagem.

**ASSISTÊNCIA TÉCNICA**

Para solicitação de Assistência Técnica você consumidor deverá entrar em contato com o Lojista o qual você realizou a compra deste produto e solicitar a assistência técnica das peças avariadas. A garantia abrange todas as peças, partes e componentes que eventualmente venham apresentar defeito de fabricação no prazo de 03 (três) meses, contando a partir da entrega do produto ao consumidor, mediante nota fiscal de compra. Se houver qualquer alteração na estrutura do produto ou ocorrer defeito por negligência do montador/consumidor em relação a instrução de montagem e manuseio, não será fornecido assistência técnica gratuita.

**ADVERTENCIA**

Para limpieza de su móvil, use una flanela seca o húmeda, y no utilice productos químicos que puedan dañar su producto.

**SISTEMA DE MONTAJE**

El sistema de montaje de los productos funciona de acuerdo con el orden creciente de los números indicados en el dibujo. Ej.: 01, 02, 03, 04... hasta la conclusión del montaje.

**ASISTENCIA TÉCNICA**

Para solicitar Asistencia Técnica, el consumidor debe comunicarse con el Comercio que usted realizó la compra de este producto y solicita asistencia técnica para las partes dañadas. La garantía cubre todas las partes, piezas y componentes que eventualmente puedan presentar defecto de fabricación en el plazo de 03 (tres) meses, contados a partir de la entrega del producto al consumidor, mediante factura de compra. Si se produce algún cambio en la estructura del producto o se produce un defecto por negligencia del montador/consumidor en relación con las instrucciones de montaje y manipulación, no se prestará asistencia técnica gratuita.

**NOTICE**

To clean your furniture, use a dry or wet cloth, and do not use chemicals that may damage your product.

**ASSEMBLY SYSTEM**











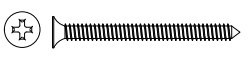

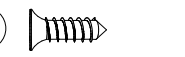
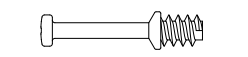



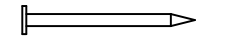
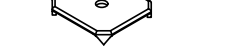



The products' assembly system works according to the increasing order of the indicated numbers. For example: 01, 02, 03, 04 ... to the end of the assembly.

**TECHNICAL ASSISTANCE**

To request Technical Assistance, the consumer must contact the retailer from whom you purchased this product and request technical assistance for the damaged parts. The warranty covers all parts, parts and components that may eventually present a manufacturing defect within a period of 03 (three) months, counting from the delivery of the product to the consumer, by means of a purchase invoice. If there is any change in the structure of the product or defect occurs due to negligence of the assembler/consumer in relation to the assembly and handling instruction, free technical assistance will not be provided.

# ACESSÓRIOS | ACCESORIOS | ACCESSORIES



ITM/D344-

<b>A</b> x49  Parafuso 4,0x45mm CHT.	<b>B</b> x42  Parafuso 3,5x40mm CHT.	<b>C</b> x18  Parafuso 3,0x16mm CHT.	<b>D</b> x332  Parafuso 4,0x14mm CHT.
<b>E</b> x3  Parafuso Minifix	<b>F</b> x3  Tambor Minifix	<b>G</b> x156  Cavilha Plástica 8x25mm	<b>H</b> x4  Sachê de Cola
<b>I</b> x229  Prego 10x10mm	<b>J</b> x75  Fixador de Fundo	<b>K</b> x28  Cantoneira Plástica 20x20mm	<b>L</b> x18  Cantoneira Suporte triangular
<b>M</b> x24  Dob 35mm POP Alta C/Amortecedor + Calço Fixo	<b>N</b> x6  Suporte Cabideiro Oblongo	<b>O</b> x9 Pares  Corrediça Telescópica 300x30mm	<b>P</b> x8  Pé "U" 50x40x100mm
<b>Q</b> x1  Etiqueta Resinada Henn	<b>R</b> x1  Cabideiro Oblongo Estriado 409mm	<b>S</b> x2  Cabideiro Oblongo Estriado 839mm	<b>T</b> x2  Perfil "H" 1758mm
<b>U</b> x30  Adesivo Tapa Parafuso 10mm	<b>V</b> x2  Adesivo Tapa Parafuso 17mm	<b>W</b> x2  Giz de Correção	

# MONTAGEM 15 | MONTAJE 15 | ASSEMBLY 15

ITM/D344-

## ACESSÓRIOS REQUERIDOS

Q	HENN	01	V		02
U		30	W		02

Pesos máximos recomendados com carga distribuída  
 Peso máximo recomendado con la carga distribuida  
 Recommended maximum weight with distributed load.

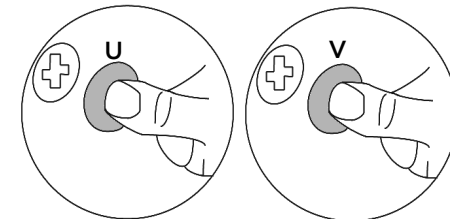
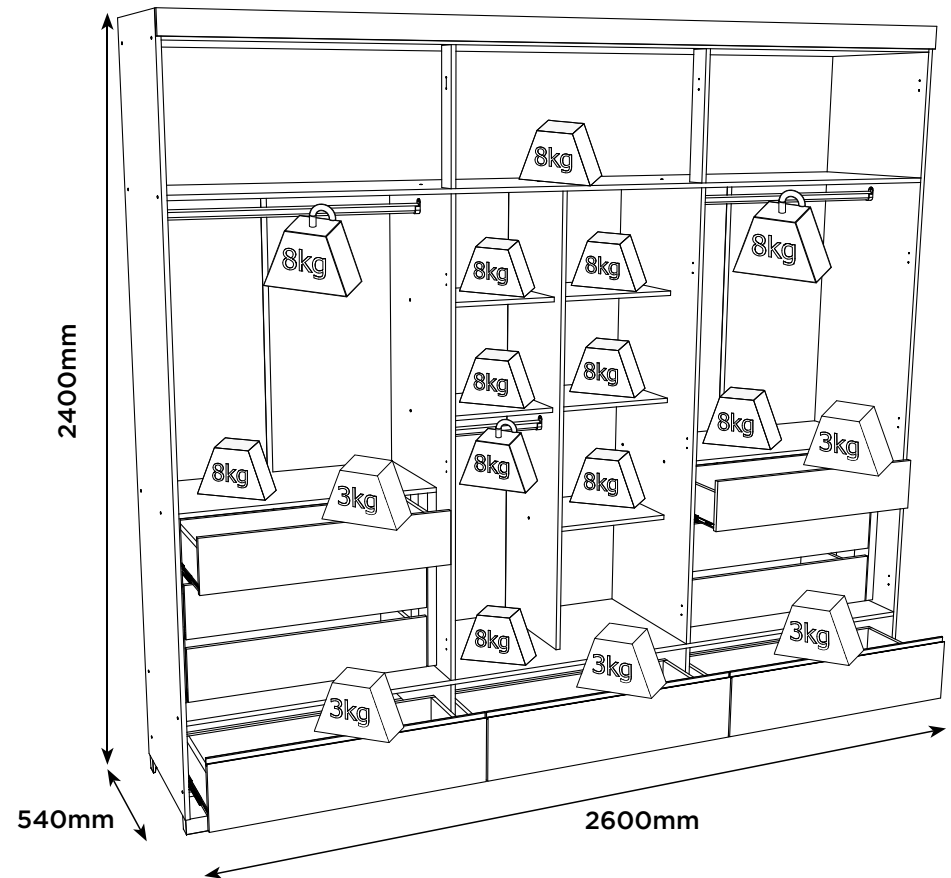

PERFECT CORRECTION  
CORRECCIÓN PERFECTA

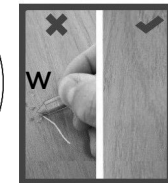

**MONTAGEM 14** | MONTAJE 14 | ASSEMBLY 14

PEÇAS REQUERIDAS

32	PORTA	x6
----	-------	----

ACESSÓRIOS REQUERIDOS

D		96
---	--	----

FERRAMENTAS NECESSÁRIAS

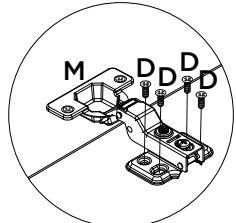
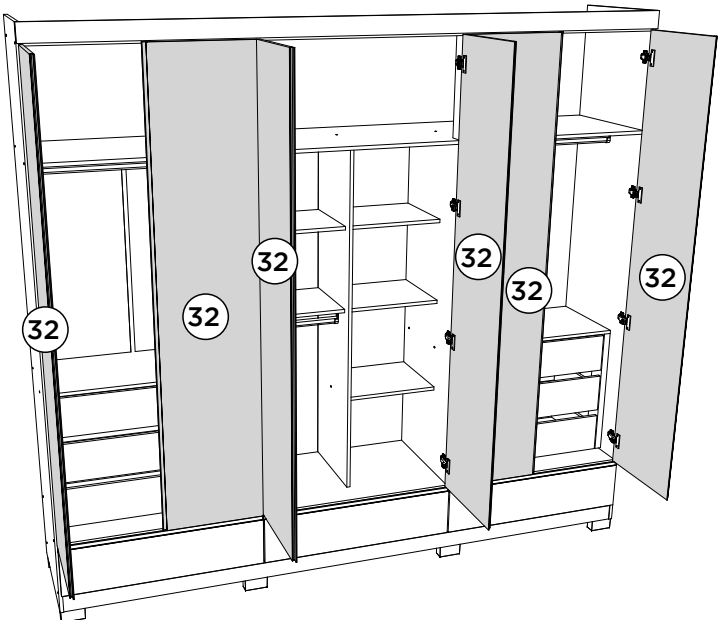
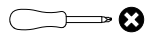

**PARAFUSOS EM ESCALA 1:1** | TORNILLOS A ESCALA 1:1 | 1:1 SCALE SCREWS

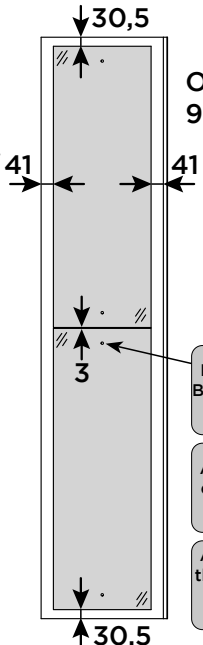
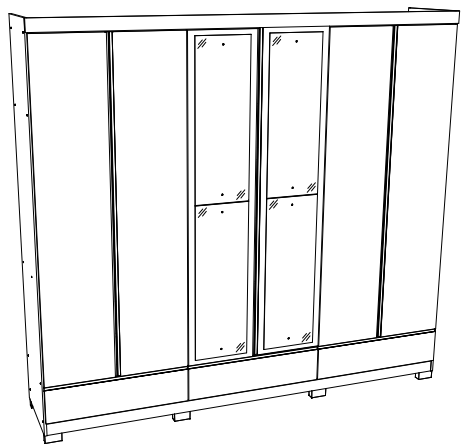
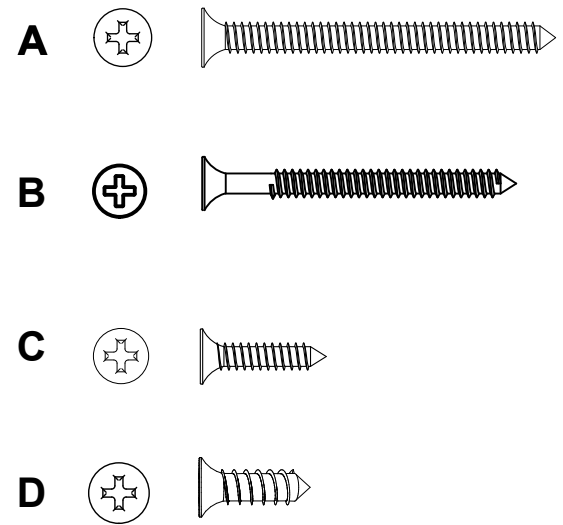

**!**  
**O965-64 - Kit Espelho**  
**950x330x3mm com 2 unidades**

Esse Kit Espelho é opcional e é vendido separadamente.

Este juego de espejos es opcional y se vende por separado.

This Mirror Kit is optional and sold separately.

Fixar o Espelho com a Bucha e o Parafuso, que acompanha o kit.

Medidas em mm

Medidas en mm

Measurements in mm

Arreglar el espejo con el Casquillo y Tornillo, que viene con el kit.

Utilizar a parafusadeira com o torque 3.

Attach the Mirror with the Bushing and Screw, which accompanies the kit.

Utilice el destornillador con torque 3.

Use the screwdriver with torque 3.

## LISTA DE PEÇAS | LISTA DE PIEZAS | LIST OF PIECES





Item	Caixa Caja Box	Qty Ctd Qty	Descrição Descripción Description	Dimensões (mm)   Dimensiones (mm)   Dimensions (mm)		
				Comprimento Largo Length	Largura Ancho Width	Espessura Grosor Thickness
1	4/5	1	RODAPÉ FRONTAL   FALDÓN DELANTERO   FRONT SKIRTING	2571	73	15
2	3/5	2	TRAVESSA DO RODAPÉ   ZÓCALO TRAVESSAÑO   BASEBOARD CROSSBOARD	484	73	15
3	4/5	1	RODAPÉ TRASEIRO   ZÓCALO TRASERO   REAR BASEBOARD	2571	73	15
4	4/5	1	TRAVESSA BASE FRONTAL   TRAVESÍA BASE FRONTAL   FRONT BASE CROSSMEMBER	2571	80	15
5	4/5	1	TRAVESSA BASE TRASEIRA   TRAVESSAÑO BASE TRASERO   REAR BASE CROSSMEMBER	2571	80	15
6	3/5	2	DIVISÃO DAS GAVETAS   DIVISIÓN DE CAJONES   DRAWER DIVISION	520	210	15
7	4/5	1	BASE   BASE   BASE	2571	520	15
8	2/5	1	DIVISÃO ESQUERDA   DIVISIÓN IZQUIERDA   LEFT DIVISION	1525	520	15
9 = 18	1/5	1	TAMPO DAS GAVETAS   TAPA DE LOS CAJONES   DRAWER TOPS	847	400	15
10	3/5	1	LATERAL ESQUERDA   LATERAL IZQUIERDO   LEFT BACK	2350	520	15
11 = 13	1/5 e 2/5	2	PRATELEIRA   ESTANTE   SHELF	416	350	15
12	1/5	1	DIVISÃO   DIVISIÓN   DIVISION	1525	400	15
13 = 11	2/5	3	PRATELEIRA   ESTANTE   SHELF	416	350	15
14	2/5	1	DIVISÃO DIREITA   DIVISIÓN DERECHA   RIGHT DIVISION	1525	520	15
15	4/5	1	CHÃO DO MALEIRO   SUELO DEL MALEIRO   TRUNK FLOOR	2571	520	15
16	2/5	2	RIPA DO MALEIRO   LISTÓN DEL MALETERO   TRUNK SLAT	414	73	75
17	4/5	1	TAMPO   TAPA   TOP	2571	520	15
18 = 9	1/5	1	TAMPO DAS GAVETAS   TAPA DE LOS CAJONES   DRAWER TOPS	847	400	15
19	3/5	1	LATERAL DIREITA   DERECHO LATERAL   RIGHT BACK	2350	520	15
20	2/5	8	RIPA LATERAL   LISTÓN LATERAL   SIDE STRIP	577	80	30
21	4/5	1	CHAPÉU   SOMBRERO   HAT	2599	73	15
22	4/5	1	FUNDO SUPERIOR   FONDO SUPERIOR   TOP FUND	2595	435	3
23	3/5	6	FUNDO   FONDO   BOTTOM	1773	430	3
24	2/5	3	FRENTE DE GAVETA MAIOR   FRENTE DE CAJÓN GRANDE   LARGER DRAWER FRONT	857	220	15
25 = 29	1/5	6	LADO DE GAVETA   LADO DEL CAJÓN   DRAWER SIDE	350	122	15
26	1/5	3	FUNDO DE GAVETA MAIOR   FONDO DE CAJÓN MAYOR   LARGER DRAWER FUND	803	361	3
27	1/5	3	RIPA DE TRÁS MAIOR   LISTÓN TRASERO MAYOR   LARGER BACK BATTEN	822	122	15
28	2/5	6	FRENTE DE GAVETA   FRENTE DE CAJÓN   DRAWER FRONT	779	170	15
29 = 25	1/5	12	LADO DE GAVETA   LADO DEL CAJÓN   DRAWER SIDE	350	122	15
30	1/5	6	FUNDO DE GAVETA RECORTADO   FONDO DE CAJÓN RECORTADO   CUT-OUT DRAWER BOTTOM	743	361	3
31	1/5	6	RIPA DE TRÁS   TIRA TRASERA   BACK STRIP	762	122	15
32	5/5	6	PORTA   PUERTA   DOOR	1964	427	15

## MONTAGEM 13 | MONTAJE 13 | ASSEMBLY 13

## PEÇAS REQUERIDAS



28	FRENTE DE GAVETA	x6
29=25	LADO DE GAVETA	x12
30	FUNDO DE GAVETA RECORTADO	x6
31	RIPA DE TRÁS	x6

## ACESSÓRIOS REQUERIDOS

B		12
C		12
D		60
H		
K		12

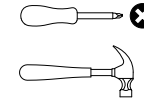
## FERRAMENTAS NECESSÁRIAS



L		12
O		12

1º

6X

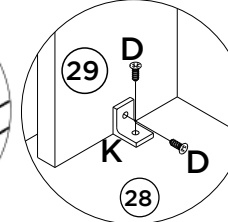
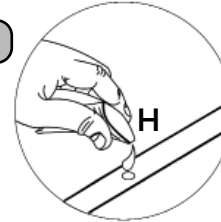

2º

6X

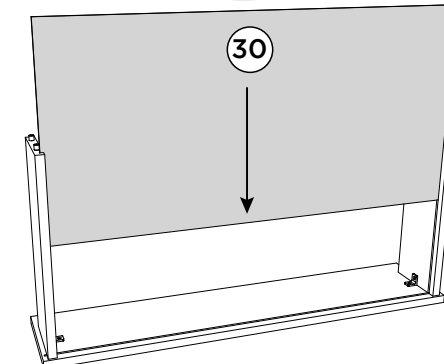
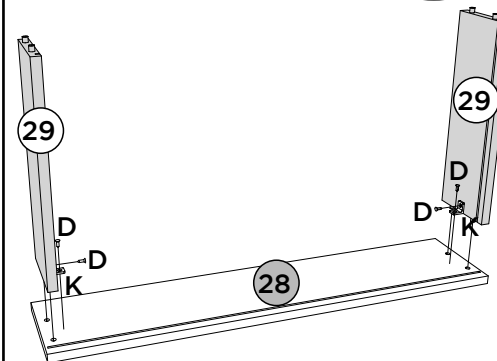
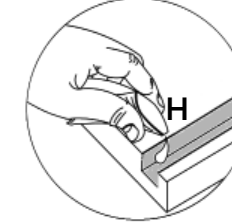

3º

6X

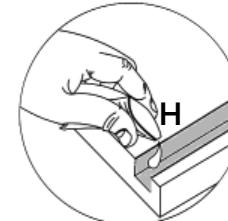

4º

6X

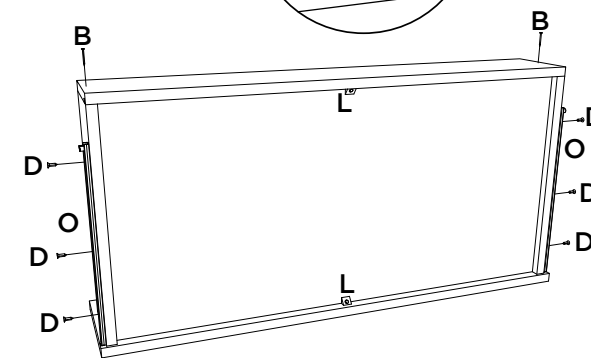
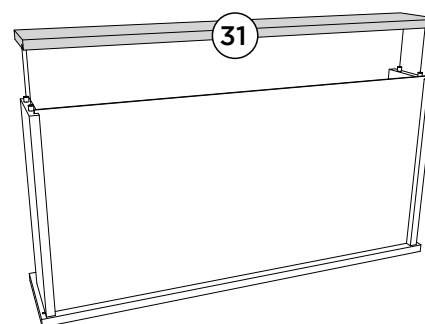
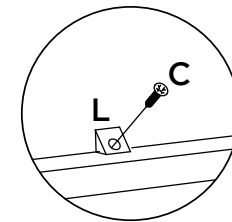

**PEÇAS REQUERIDAS**

**ACESSÓRIOS REQUERIDOS**

**FERRAMENTAS NECESSÁRIAS**

24	FRENTE DE GAVETA MAIOR	x3
25-29	LADO DE GAVETA	x6
26	FUNDO DE GAVETA MAIOR	x3
27	RIPA DE TRÁS MAIOR	x3

B		06
C		06
D		30
H		
K		06

L		06
O		06

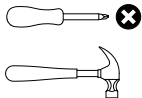

**1º 3X**

**2º 3X**

**3º 3X**

**4º 3X**

**VISTA EXPLODIDA DAS PEÇAS** | VISTA DESPIECE DE LAS PIEZAS | EXPLODED VIEW OF THE PARTS.

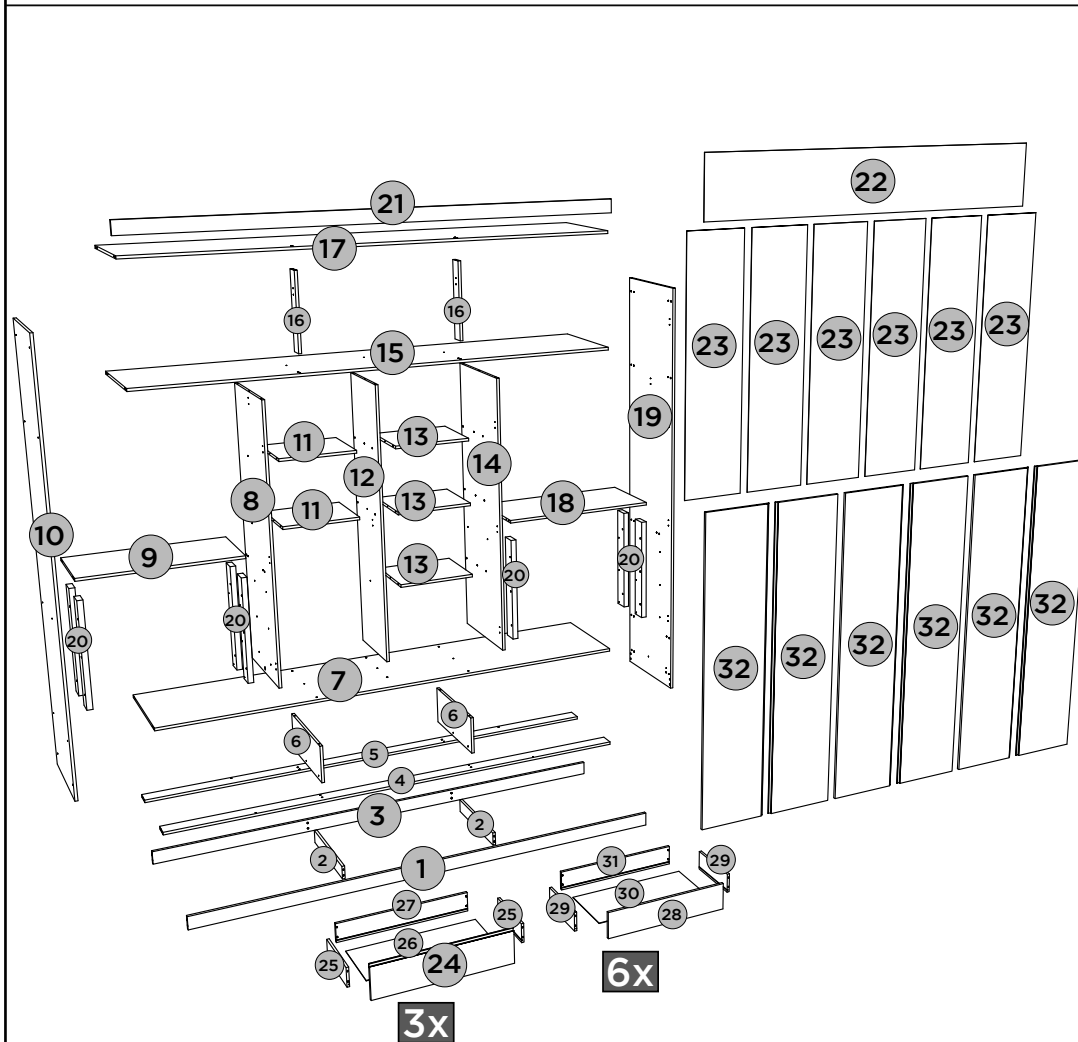

**REQUISITOS PARA MONTAGEM**  
REQUISITOS PARA LA MONTAJE | ASSEMBLY REQUIREMENTS.

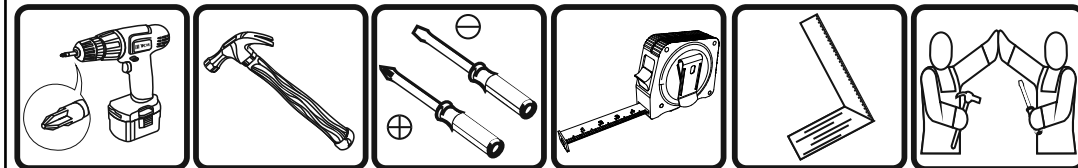

Imagens meramente ilustrativas, não acompanha o produto.  
Imágenes ilustrativas, no incluidas con el producto.  
Illustrative images, not included with the product.

PEÇAS REQUERIDAS

ACESSÓRIOS REQUERIDOS

FERRAMENTAS NECESSÁRIAS

1	RODAPÉ FRONTAL	x1
2	TRAVESSA DO RODAPÉ	x2
3	RODAPÉ TRASEIRO	x1
4	TRAVESSA FRONTAL	x1
5	TRAVESSA TRASEIRA	x1
6	DIVISÃO DAS GAVETAS	x2
11=13	PRATELEIRA	x5
16	RIPA DO MALEIRO	x2
25=29	LADO DE GAVETA	x18

D		12
G		124
H		
O		04

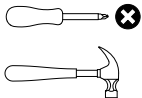

ACESSÓRIOS REQUERIDOS

FERRAMENTAS NECESSÁRIAS

D		24
O		12
R		01
S		02

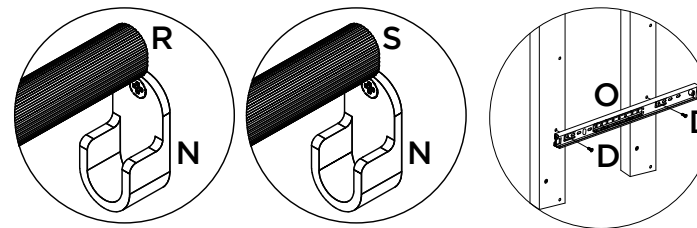
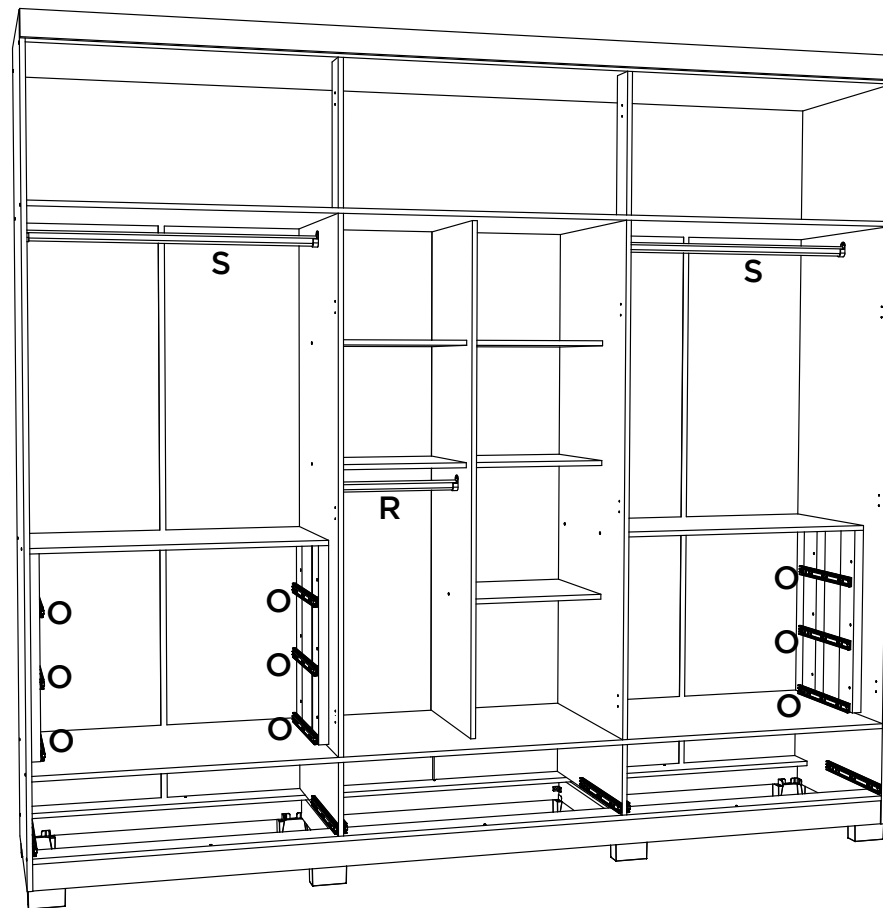
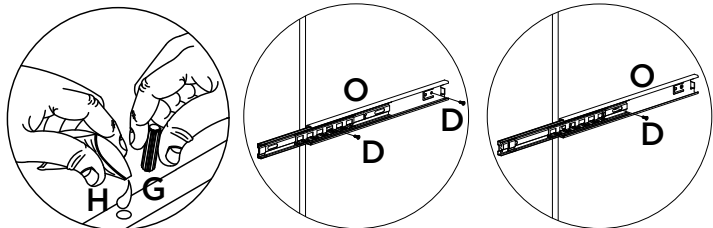
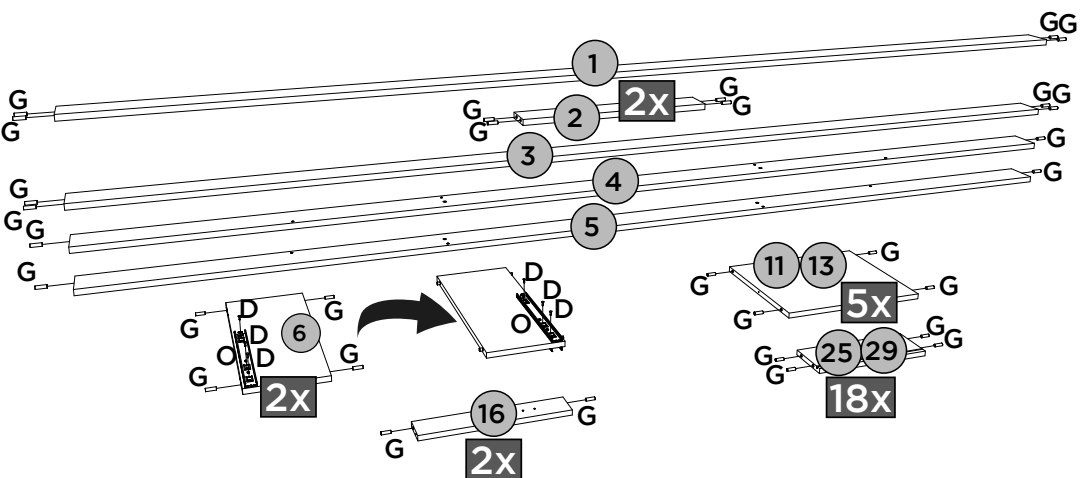
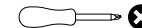

PEÇAS REQUERIDAS

ACESSÓRIOS REQUERIDOS

FERRAMENTAS NECESSÁRIAS

21	CHAPÉU	x1
22	FUNDO SUPERIOR	x1
23	FUNDO	x6

D		08
I		229
J		75
K		04
T		02

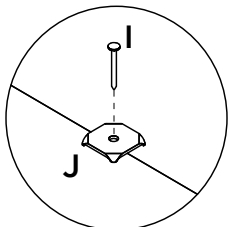
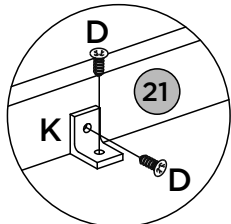
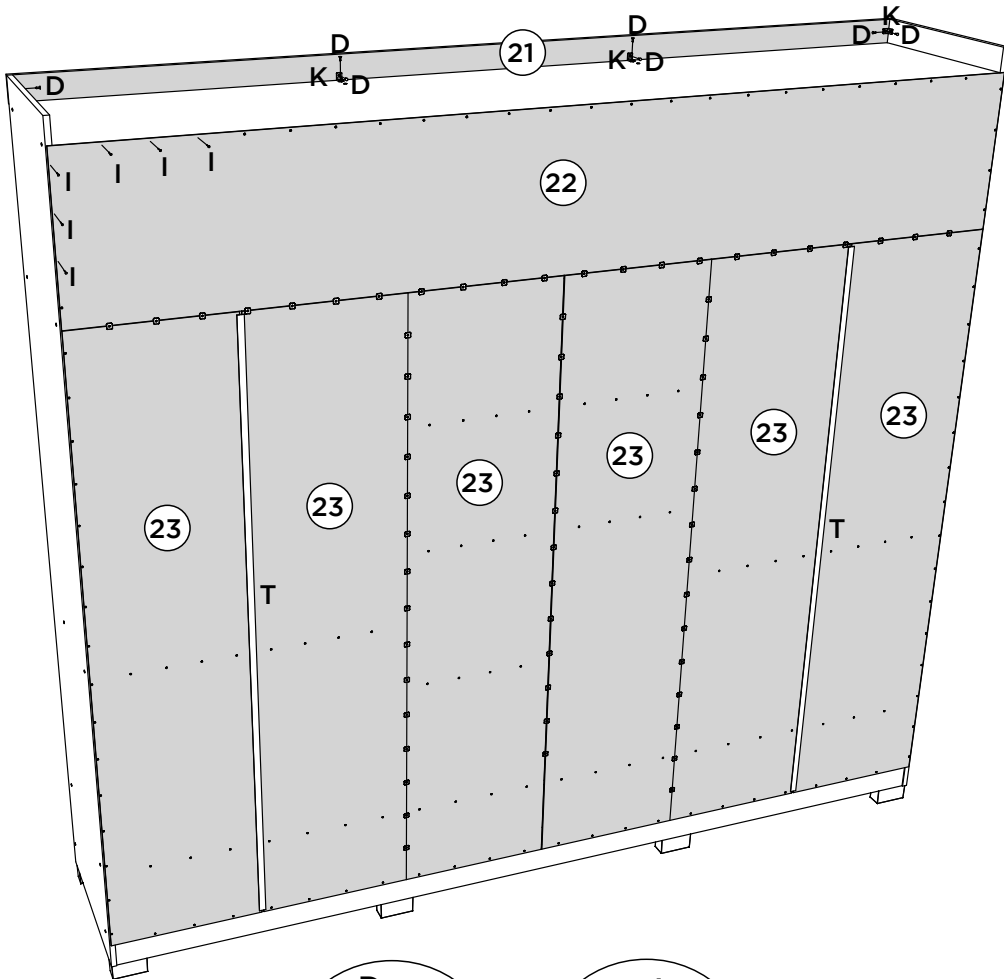
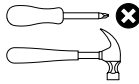

PEÇAS REQUERIDAS

ACESSÓRIOS REQUERIDOS

FERRAMENTAS NECESSÁRIAS

7	BASE	x1
10	LATERAL ESQUERDA	x1
15	CHÃO DO MALEIRO	x1
17	TAMPO	x1
19	LATERAL DIREITA	x1

D		10
E		03
G		12
H		
N		02
O		02

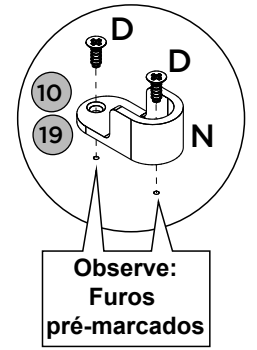
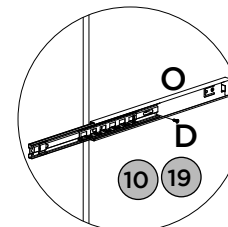
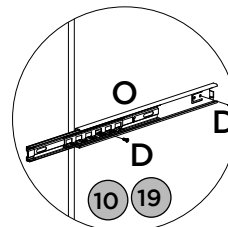
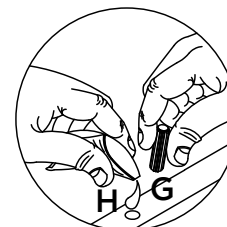
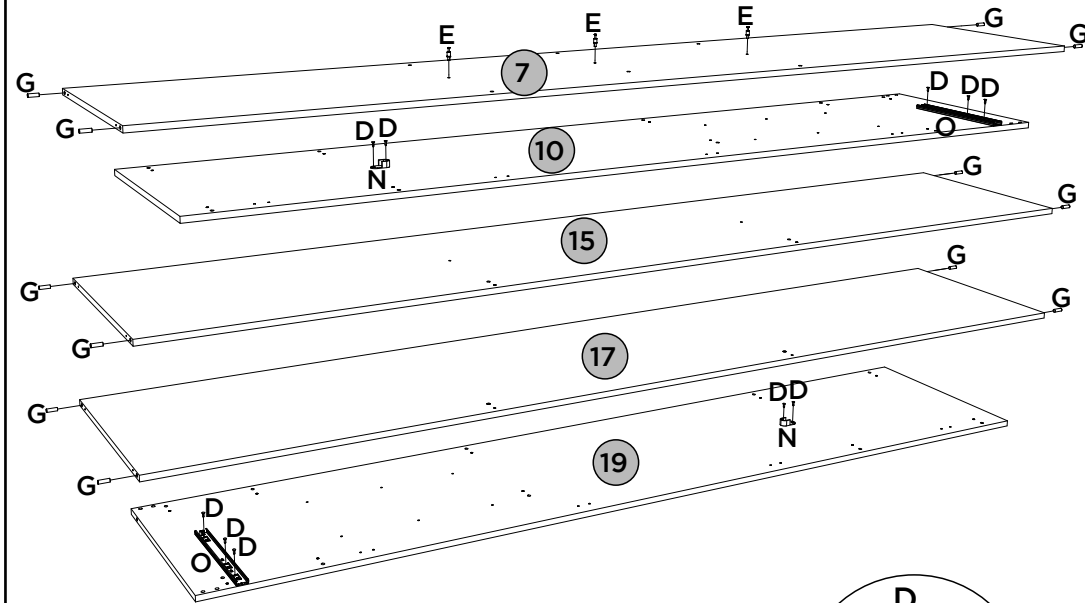
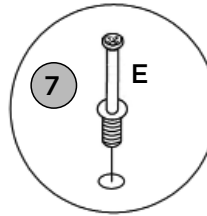
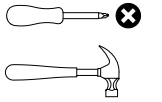

PEÇAS REQUERIDAS

8	DIVISÃO ESQUERDA	x1
9=18	TAMPO DAS GAVETAS	x2
12	DIVISÃO	x1
14	DIVISÃO DIREITA	x1

ACESSÓRIOS REQUERIDOS

D		08
G		20
H		
N		04

FERRAMENTAS NECESSÁRIAS

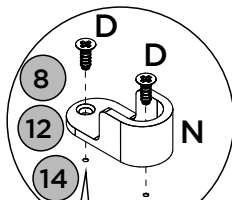
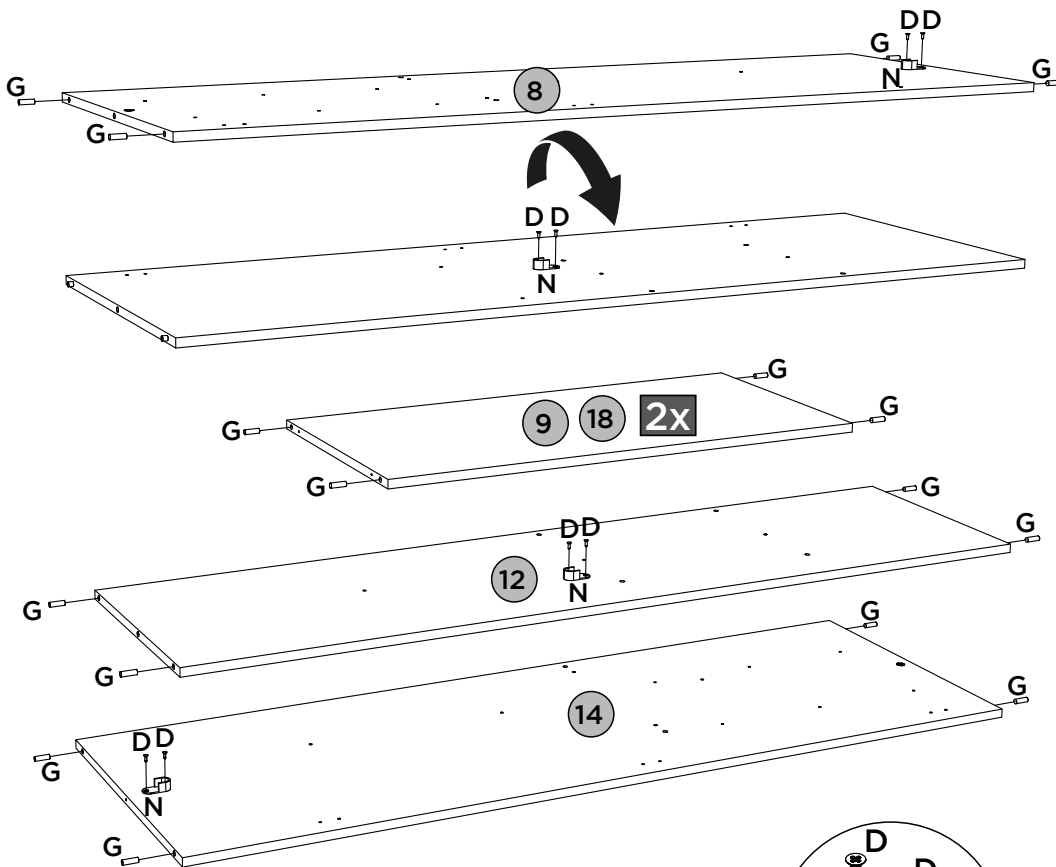
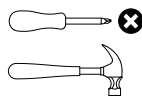

Observe:  
Furos  
pré-marcados

PEÇAS REQUERIDAS

20	RIPA LATERAL	x8
----	--------------	----

ACESSÓRIOS REQUERIDOS

B		24
---	--	----

FERRAMENTAS NECESSÁRIAS

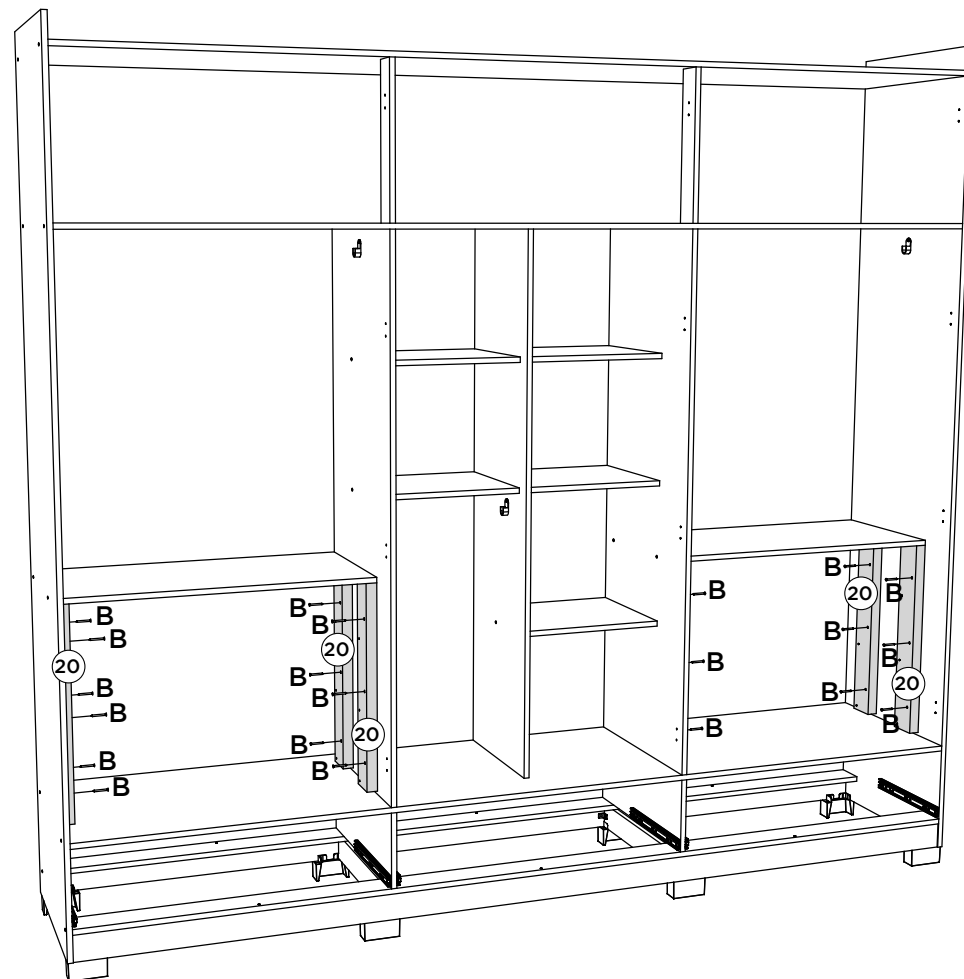
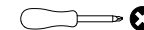



PEÇAS REQUERIDAS

ACESSÓRIOS REQUERIDOS

FERRAMENTAS NECESSÁRIAS

17	TAMPO	x1
18=9	TAMPO DAS GAVETAS	x1
19	LATERAL DIREITA	x1

A			16
---	---	---	----

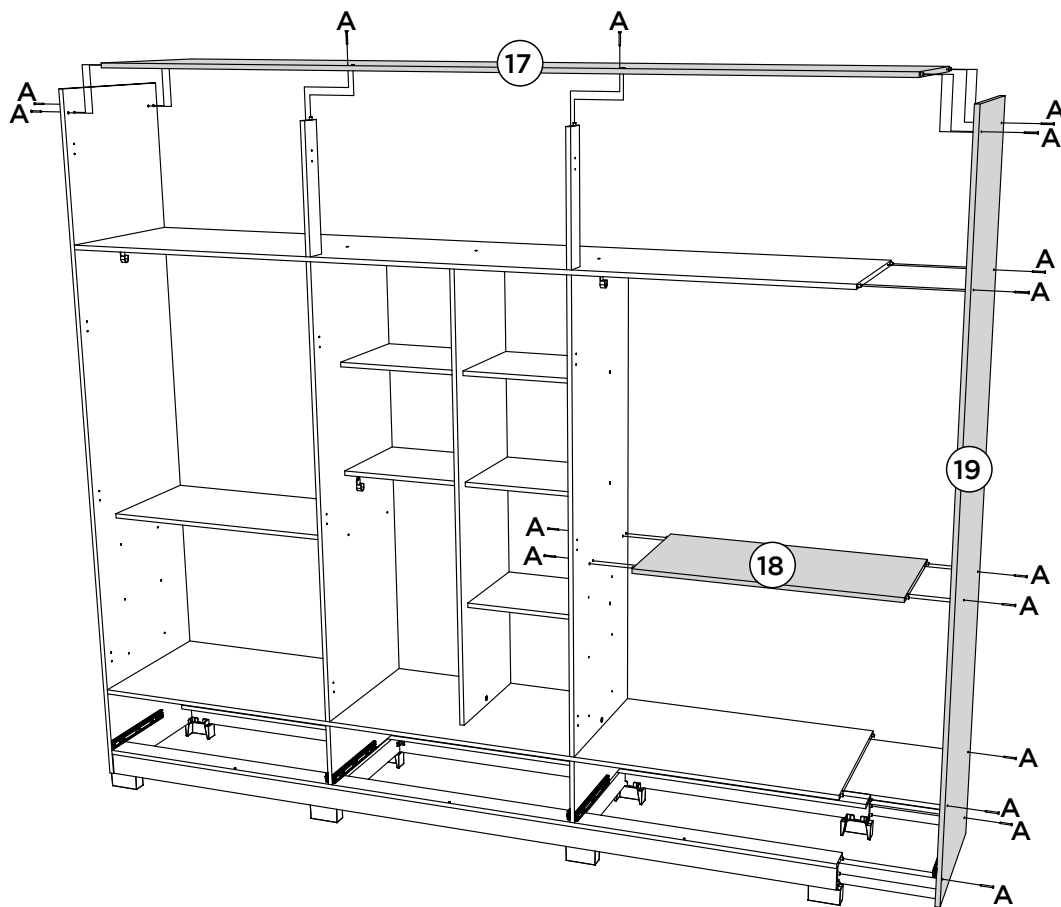
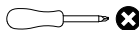



PEÇAS REQUERIDAS

ACESSÓRIOS REQUERIDOS

FERRAMENTAS NECESSÁRIAS

32	PORTA	x6
----	-------	----

D			48
M			24

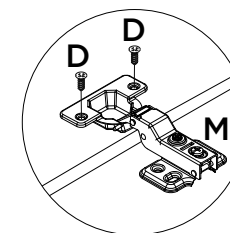
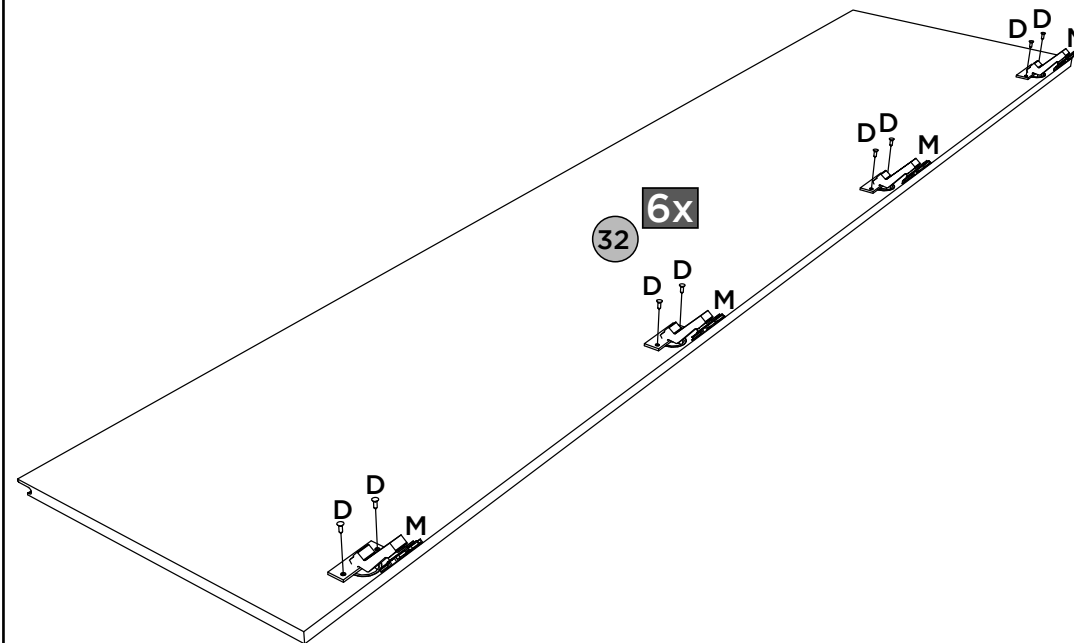
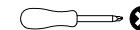

# MONTAGEM 1 | MONTAJE 1 | ASSEMBLY 1

ITM/D344-

## PEÇAS REQUERIDAS

1	RODAPÉ FRONTAL	x1
2	TRAVESSA DO RODAPÉ	x2
3	RODAPÉ TRASEIRO	x1

## ACESSÓRIOS REQUERIDOS

D		08
K		04

## FERRAMENTAS NECESSÁRIAS

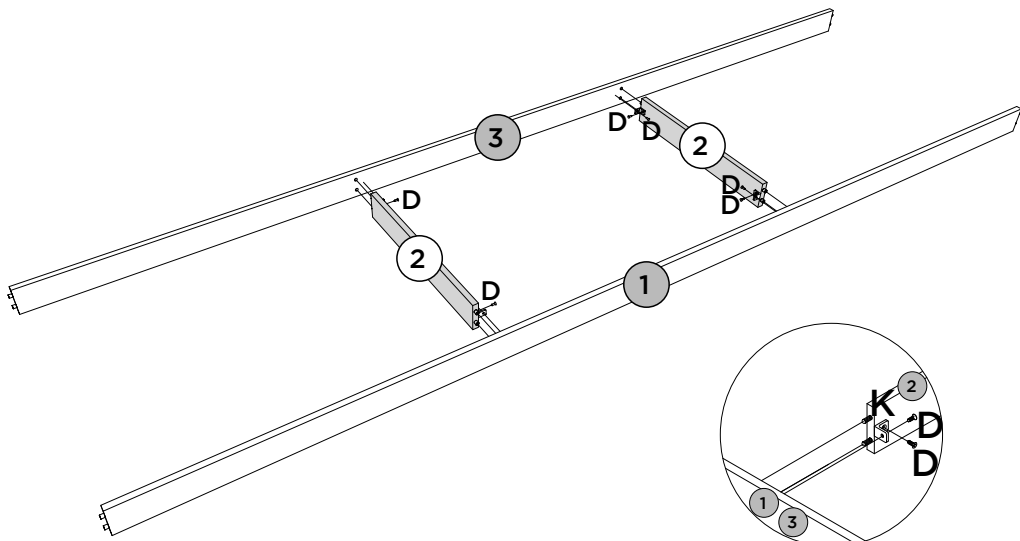
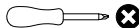

# MONTAGEM 2 | MONTAJE 2 | ASSEMBLY 2

## PEÇAS REQUERIDAS

4	TRAVESSA BASE FRONTAL	x1
5	TRAVESSA BASE TRASEIRA	x1
6	DIVISÃO DAS GAVETAS	x2

## ACESSÓRIOS REQUERIDOS

A		04
D		02
K		02

## FERRAMENTAS NECESSÁRIAS

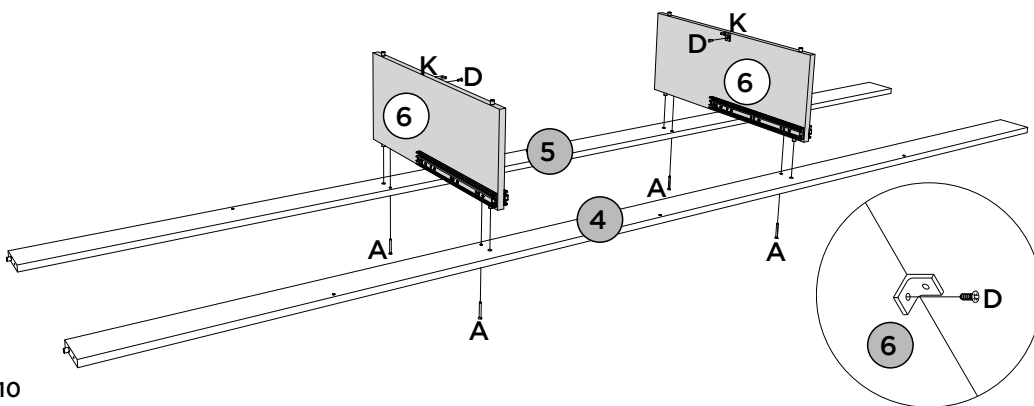
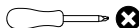

# MONTAGEM 7 | MONTAJE 7 | ASSEMBLY 7

ITM/D344-

## PEÇAS REQUERIDAS

15	CHÃO DO MALEIRO	x1
16	RIPA DO MALEIRO	x2

## ACESSÓRIOS REQUERIDOS

A		07
---	--	----

## FERRAMENTAS NECESSÁRIAS

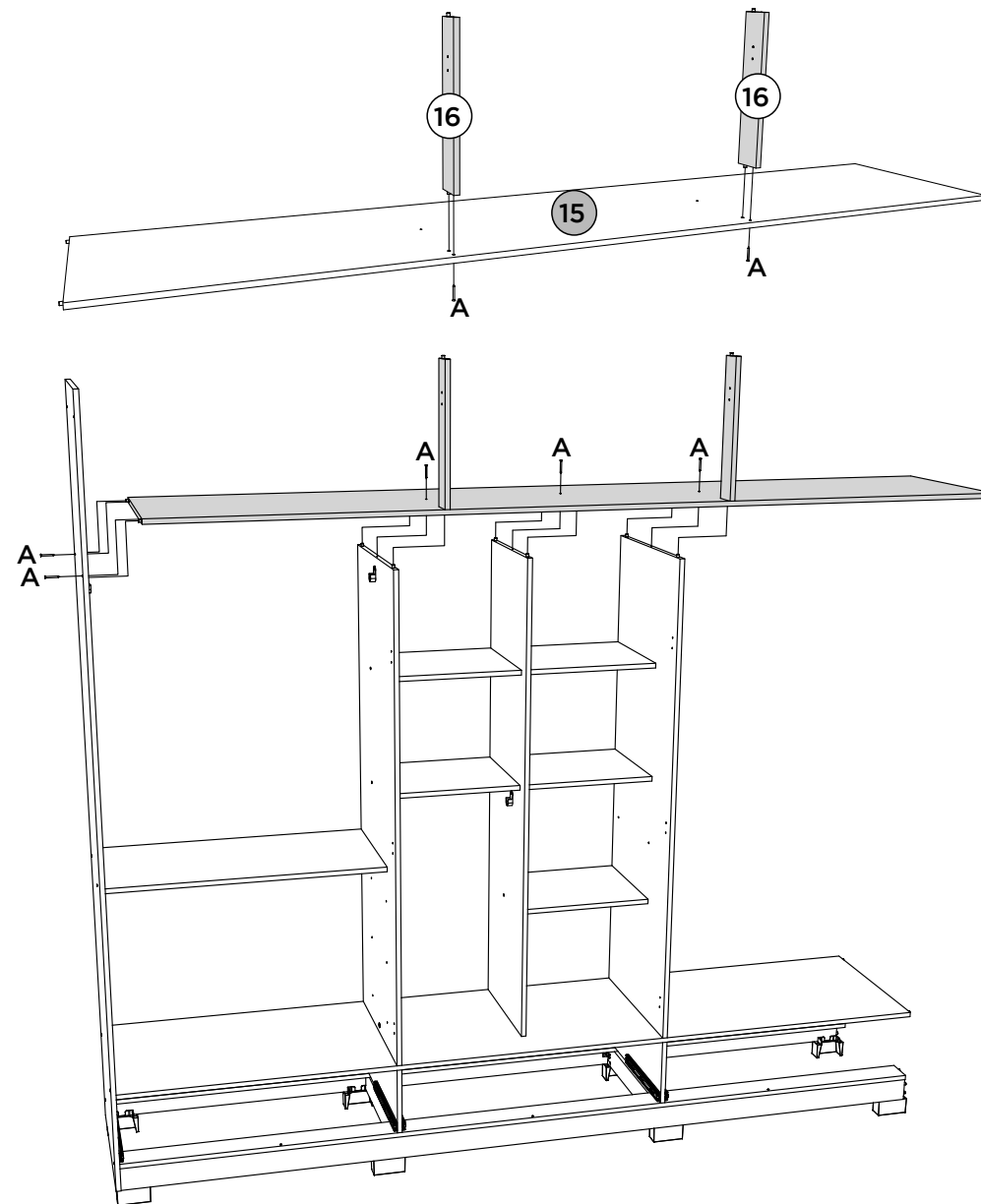
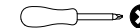





PEÇAS REQUERIDAS

ACESSÓRIOS REQUERIDOS

FERRAMENTAS NECESSÁRIAS

13=11	PRATELEIRA	x3
14	DIVISÃO DIREITA	x1

A			04
F			01

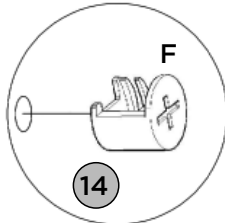
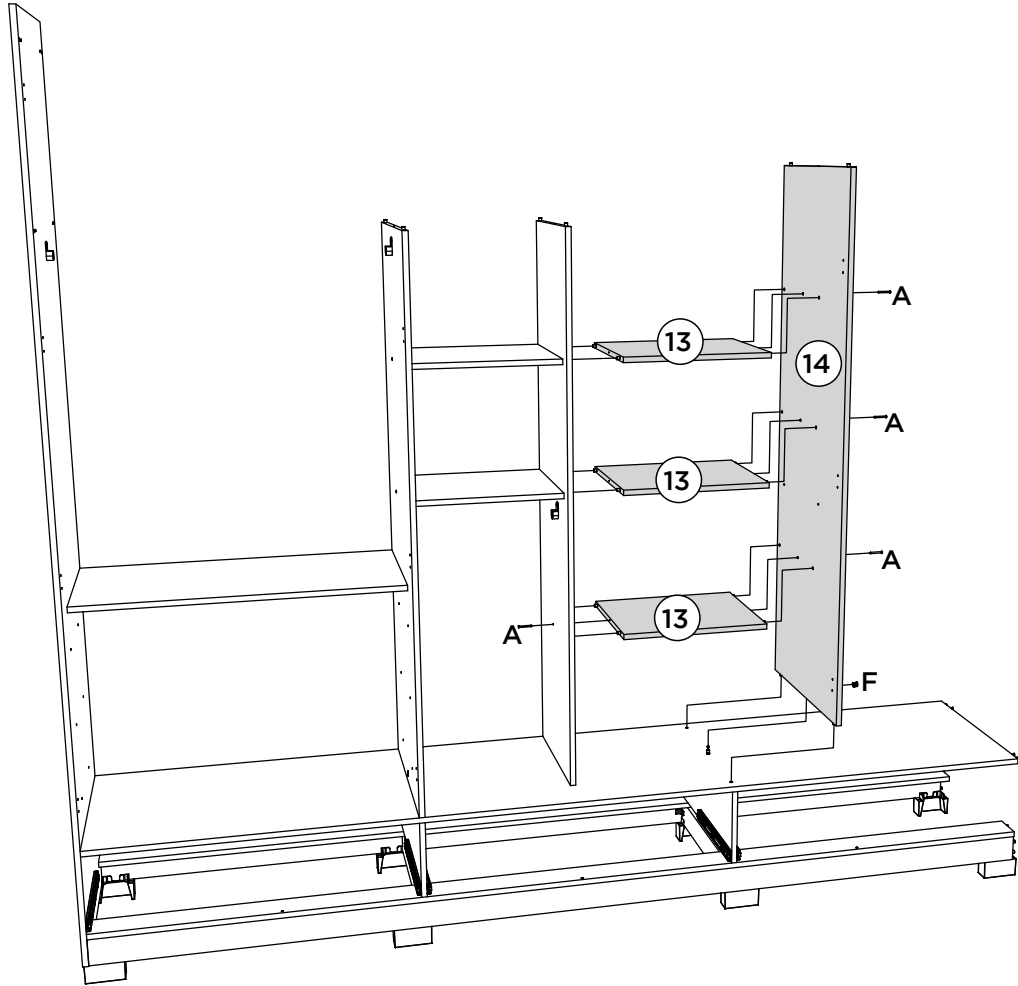
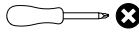





PEÇAS REQUERIDAS

ACESSÓRIOS REQUERIDOS

FERRAMENTAS NECESSÁRIAS

7	BASE	x1
---	------	----



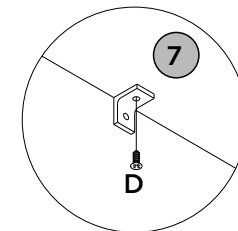
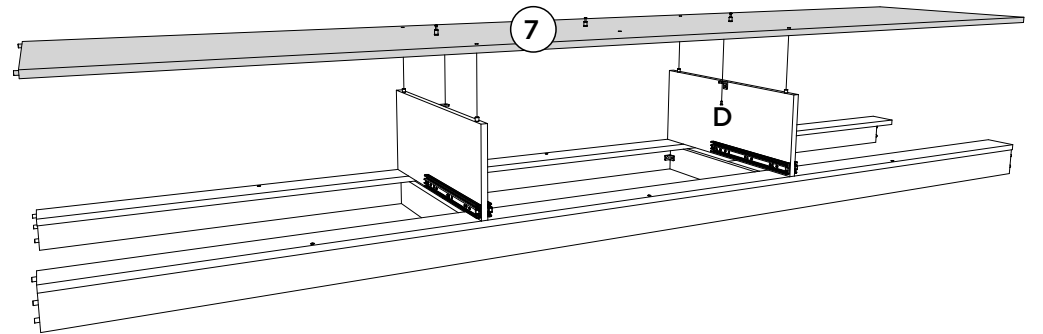
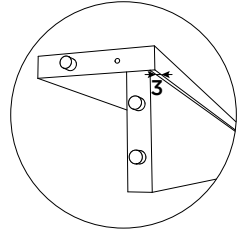
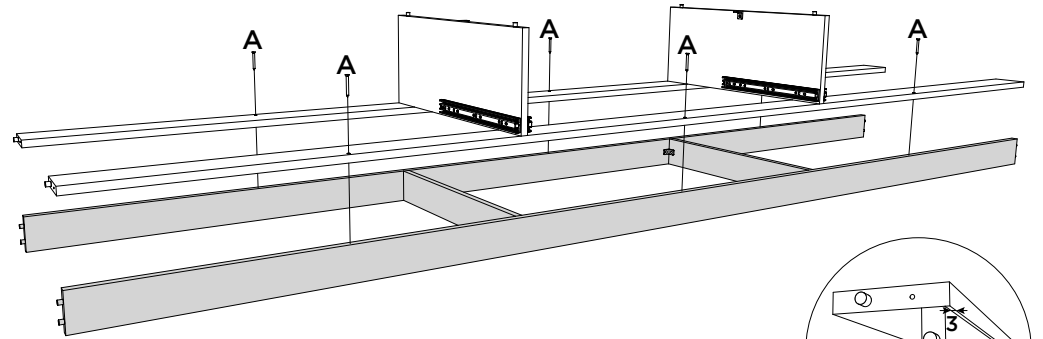

A			06
D			02



PEÇAS REQUERIDAS

8	DIVISÃO ESQUERDA	x1
9=18	TAMPO DAS GAVETAS	x1
10	LATERAL ESQUERDA	x1

ACESSÓRIOS REQUERIDOS

A		08
D		24
F		01
P		08

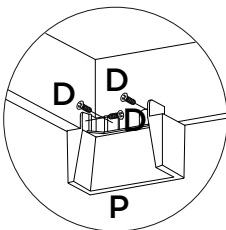
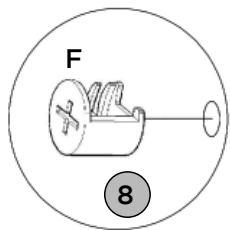
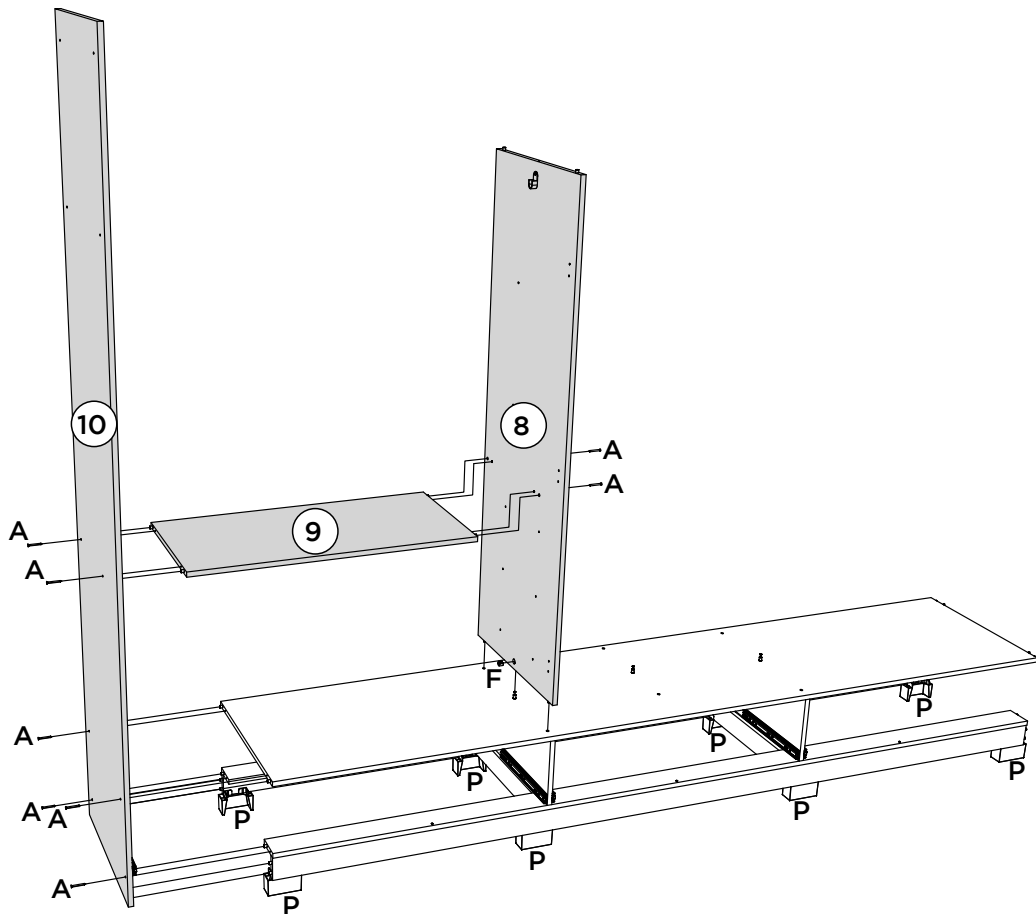
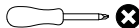

FERRAMENTAS NECESSÁRIAS



PEÇAS REQUERIDAS

11=13	PRATELEIRA	x2
12	DIVISÃO	x1

ACESSÓRIOS REQUERIDOS

A		04
F		01

FERRAMENTAS NECESSÁRIAS

