

# INSTRUÇÕES DE MONTAGEM

INSTRUCCIONES DE MONTAJE  
ASSEMBLY INSTRUCTIONS

## Kit de Cozinha Emily 06 Pçs com Cristaleira |

Kit de Cocina Emily 06 Piezas con Vitrina | Emily Kitchen Kit 06 Pieces with Glass Cabinet

CE159-05 Branco HP

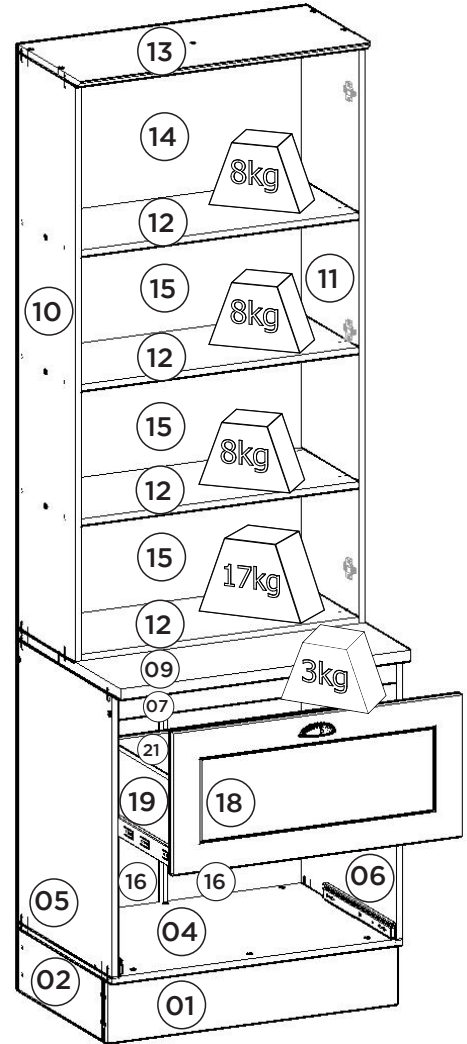
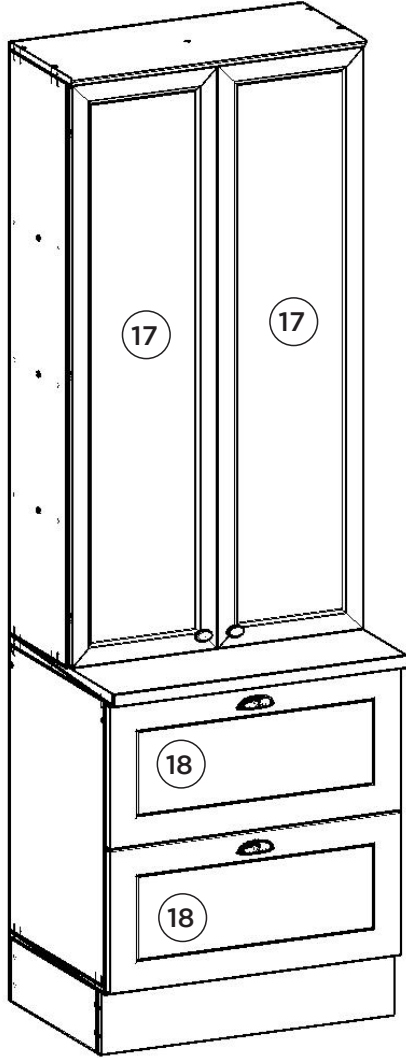

Pesos máximos recomendados com carga distribuída  
Peso máximo recomendado con la carga distribuída  
Recommended maximum weights with evenly distributed.

### Requisitos para montagem Requisitor para la montaje Assembly Requirements

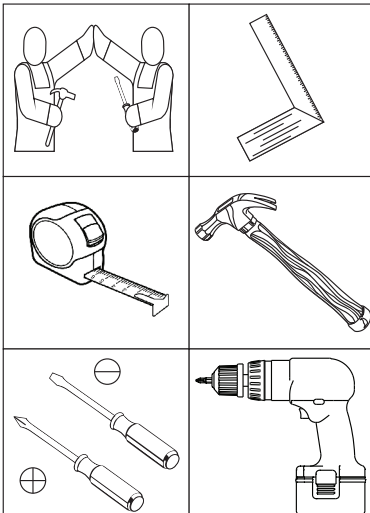

Imagens meramente ilustrativas  
Imágenes meramente ilustrativas  
Images for illustration only

### AVISO

Para limpeza de seu móvel, use uma flanela seca ou umedecida, e não utilize produtos químicos que possam danificar seu produto.

### SISTEMA DE MONTAGEM

O sistema de montagem dos produtos, funciona de acordo com a ordem crescente dos números indicados no desenho. Ex: 01, 02, 03, 04... até a conclusão da montagem.

### ADVERTENCIA

Para limpieza de su móvil, use una franela seca o húmeda, y no utilice productos químicos que puedan dañar su producto.

### SISTEMA DE MONTAJE

El sistema de montaje de los productos funciona de acuerdo con el orden creciente de los números indicados en el dibujo. Ej.: 01, 02, 03, 04... hasta la conclusión del montaje.

### NOTICE

To clean your furniture, use a dry or wet cloth, and do not use chemicals that may damage your product.

### ASSEMBLY SYSTEM

The products' assembly system works according to the increasing order of the indicated numbers. For example: 01, 02, 03, 04 ... to the end of the assembly.

1º

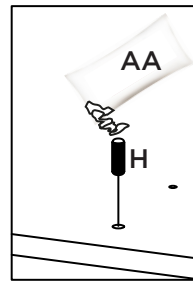
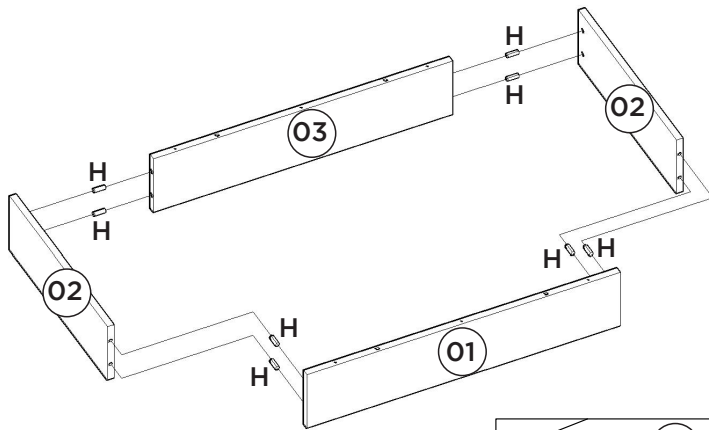

Utilizar o sachê de cola (AA) em todas as cavilhas (H) do produto.

Con el pegamento sobre (AA) en todos los pernos (H) producto.

Use the glue sachet (AA) on all the pegs (H) of the product.

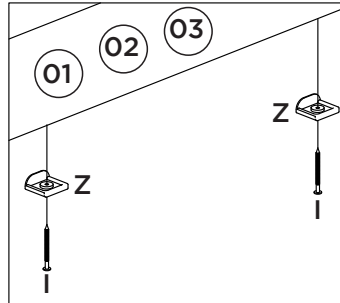
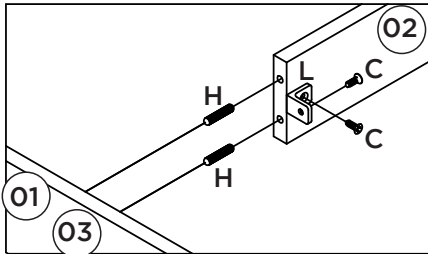

**OPCIONAL:**

O944-121 Kit Pé Cônico 145mm (vendido separadamente). Caso opte em colocar pé no produto, utilizar as pré-furações que possui na Base e fixá-lo com o Parafuso que consta no Kit.

**OPCIONAL:**

O944-121 Kit Pie Cónico 145mm (se vende por separado). Si opta por colocar pie en el producto, utilizar las pre-huracuras que tenga en la Base y fijarlo con el Tornillo que consta en el Kit.

**OPTIONAL:**

O944-121 Tapered Foot Kit 145mm (sold separately). If you choose to put foot in the product, use the pre-drillings in the Base and fix it with the Screw included in the Kit.

2º

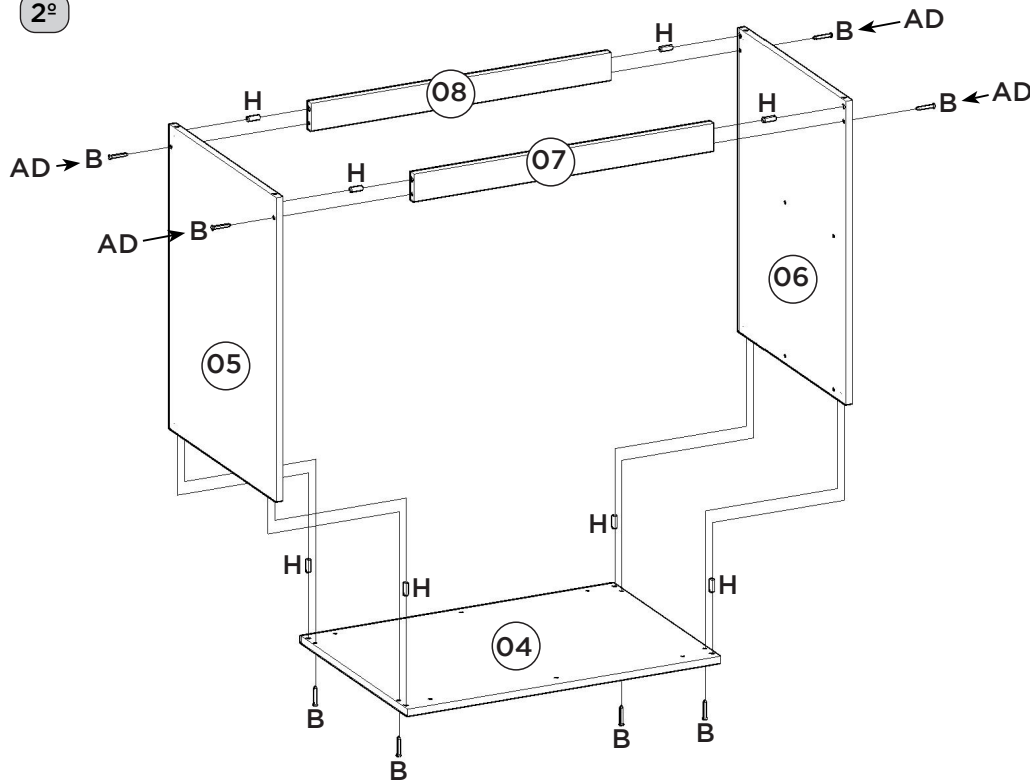

3º

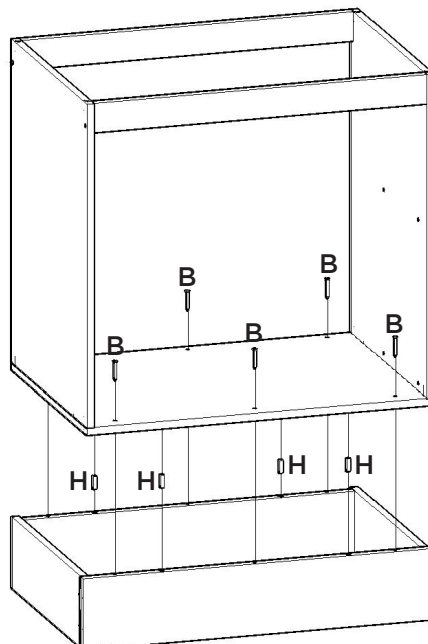

4°

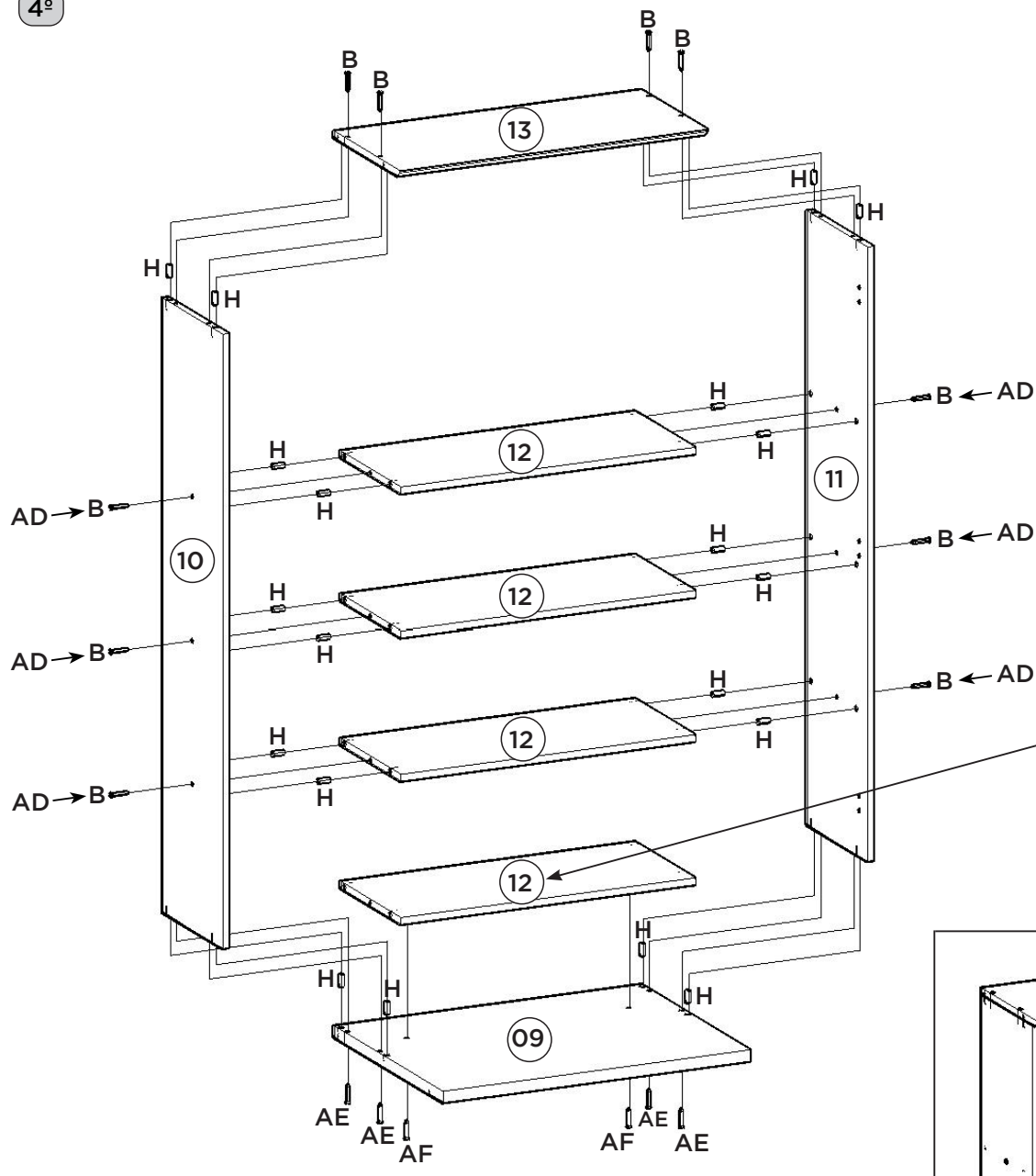

Peça (12) apenas fixada com Parafuso (AF), de baixo para cima.

Pieza (12) sólo fijada con Tornillo (AF), de abajo hacia arriba.

Part (12) only fixed with Screw (AF) from bottom to top.

5°

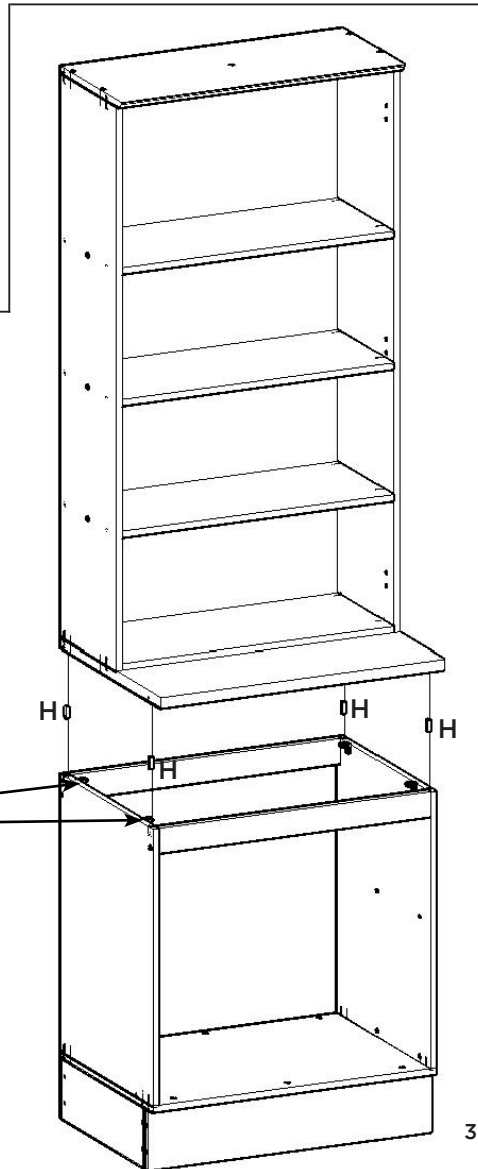
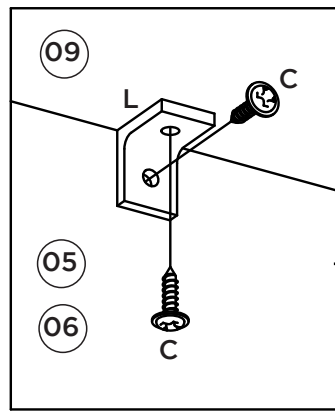

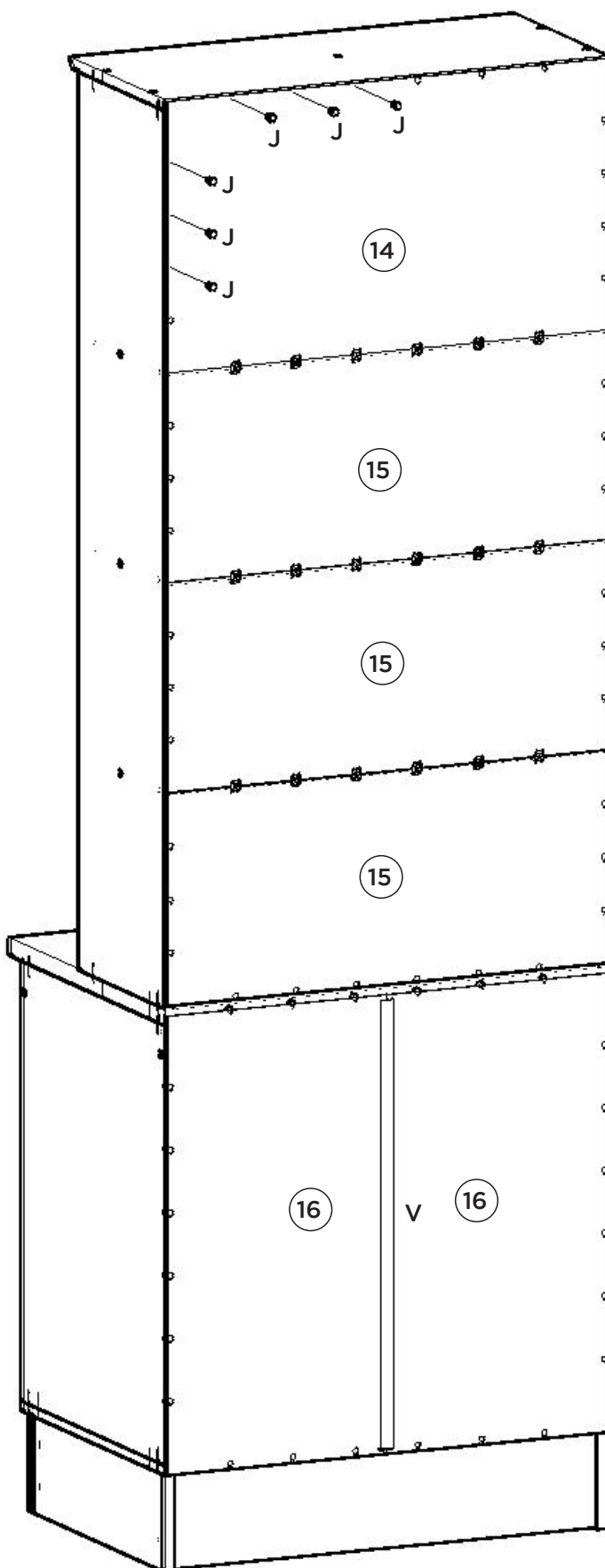
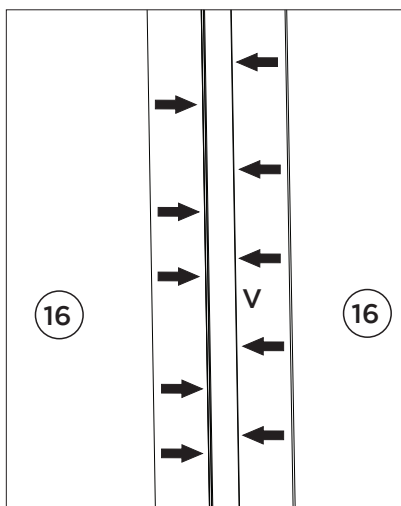
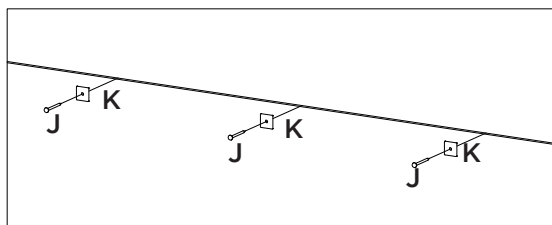

Opção Suspensa

Opción suspendida

Suspended Option

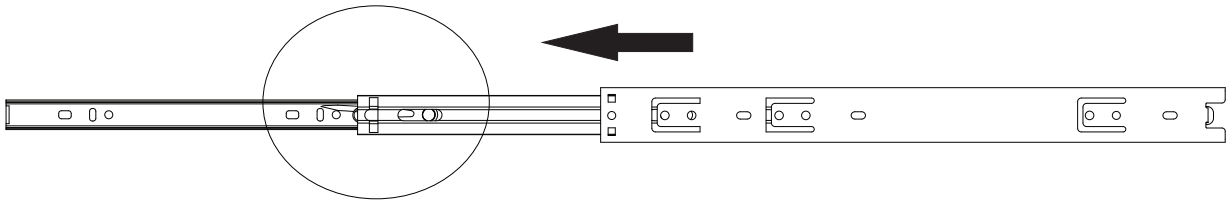
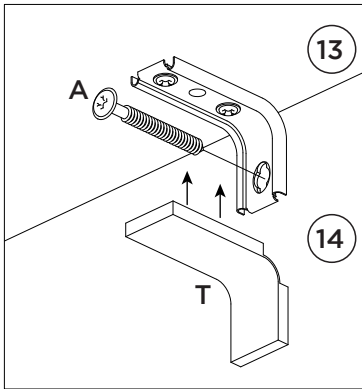
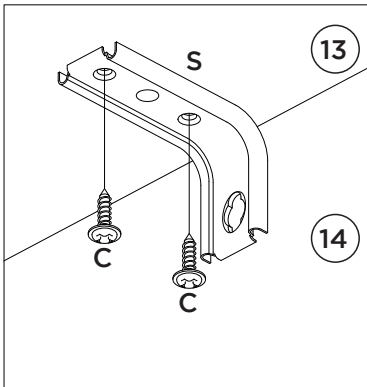
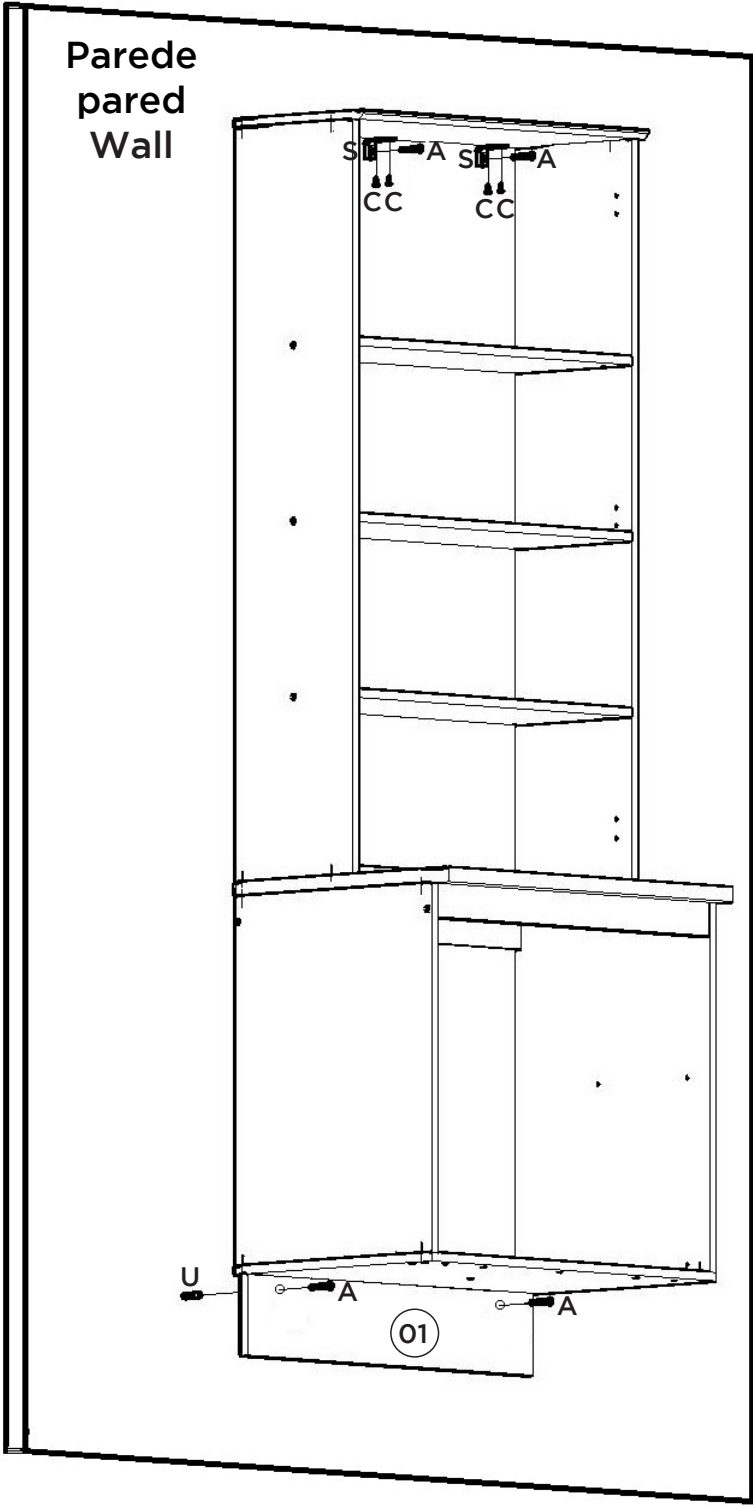

Para a desmontagem da corredeira siga a instrução ao lado.

Para el desmontaje seguimiento de diapositivas la instrucción siguiente a.

For the dismount of the sliding onem follows the instruction aside.

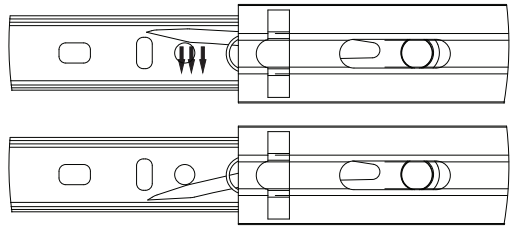

Fixar as corredeiras nessas furações  
 Fijar las diapositivas de estos agujeros  
 Fix slides in these drillings

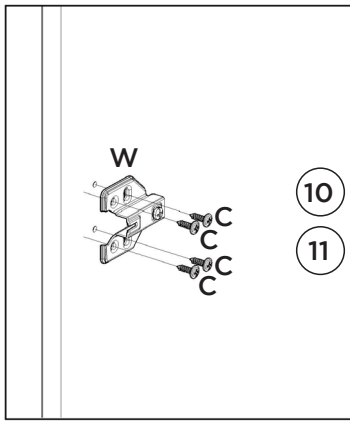

10

11

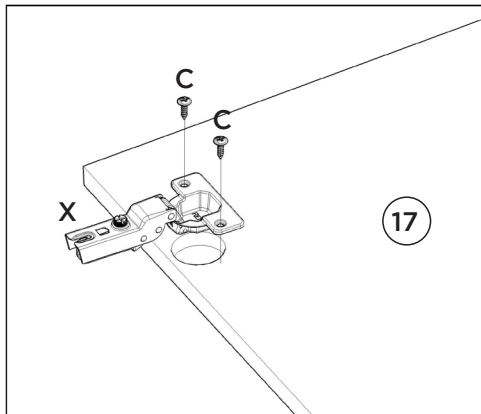

17

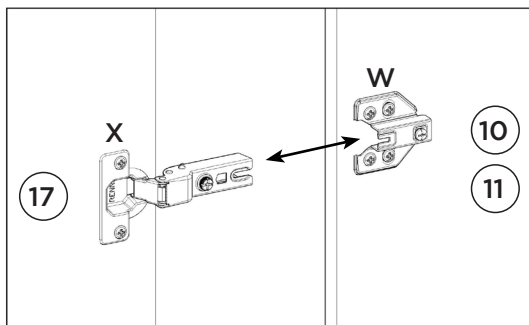

10

11

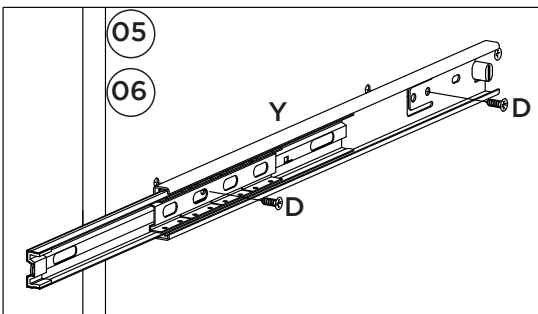

05

06

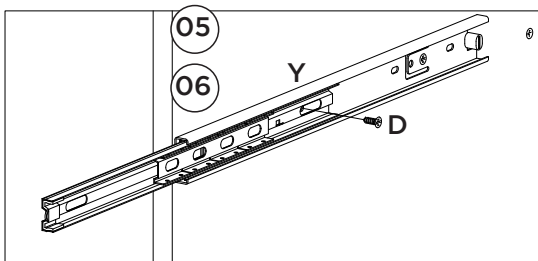

05

06

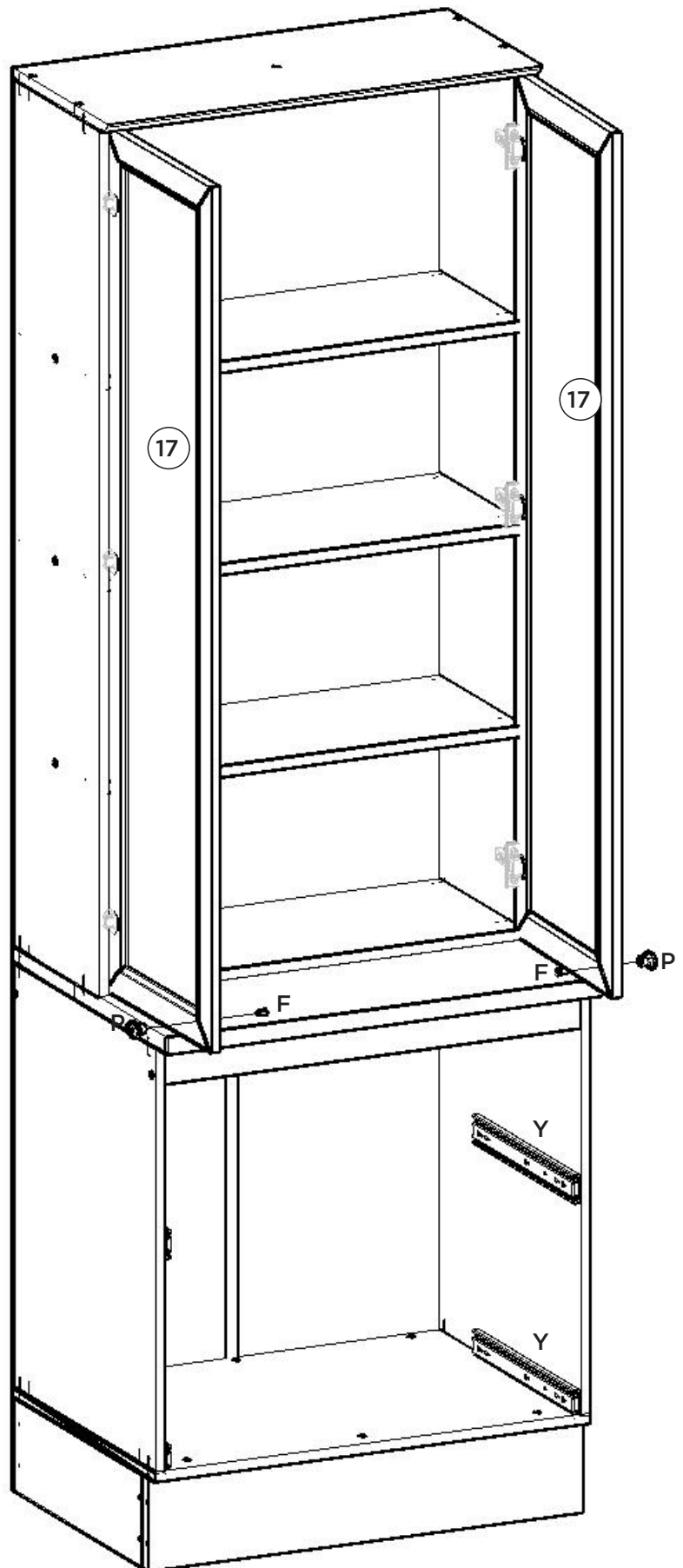

17

17

F

P

F

Y

Y

Para colocação dos puxadores, é necessário fazer a furação passante, com Broca de 5mm.

Para la colocación de las asas, es necesario perforar a través, con una broca de 5mm.

To place the handles is necessary to make the through hole, drill 5mm.

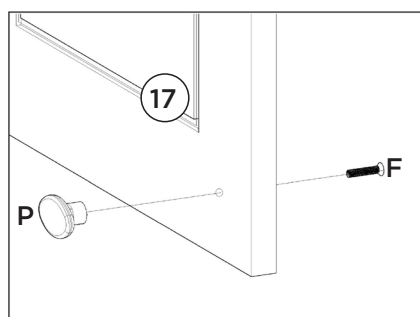

17

F



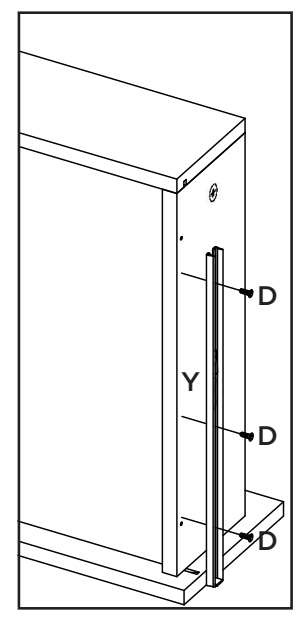
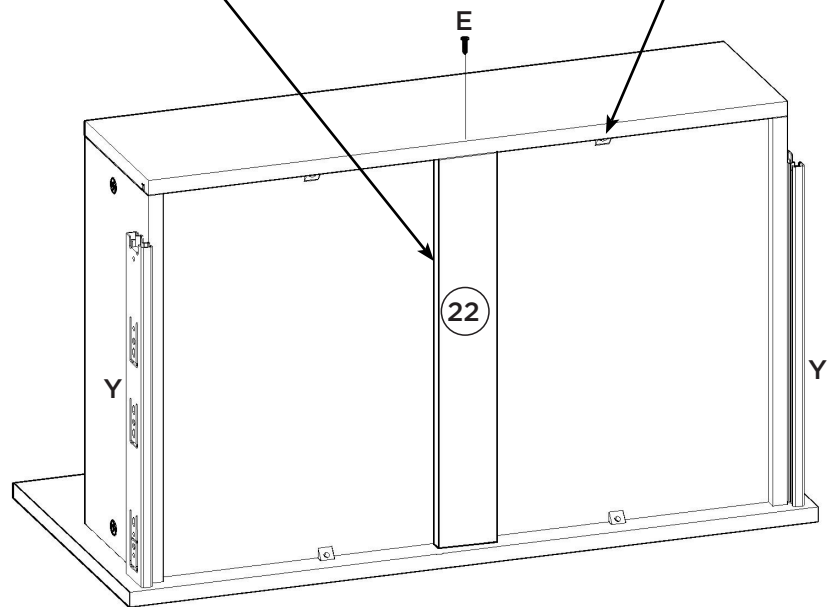
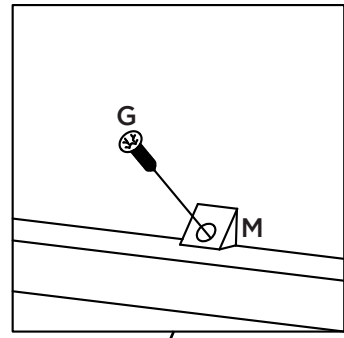
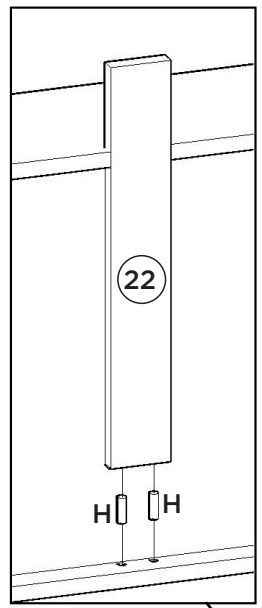
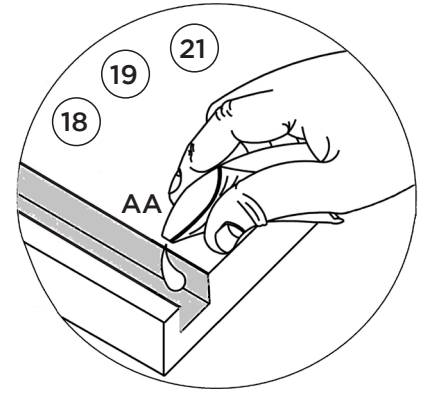
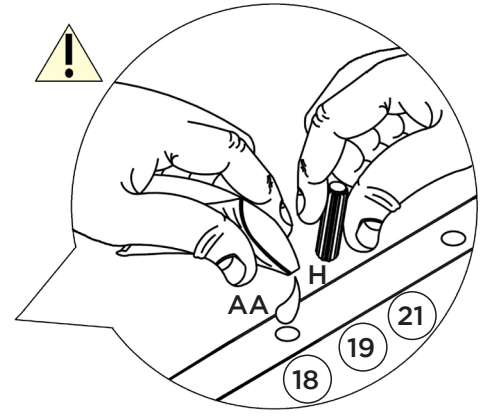
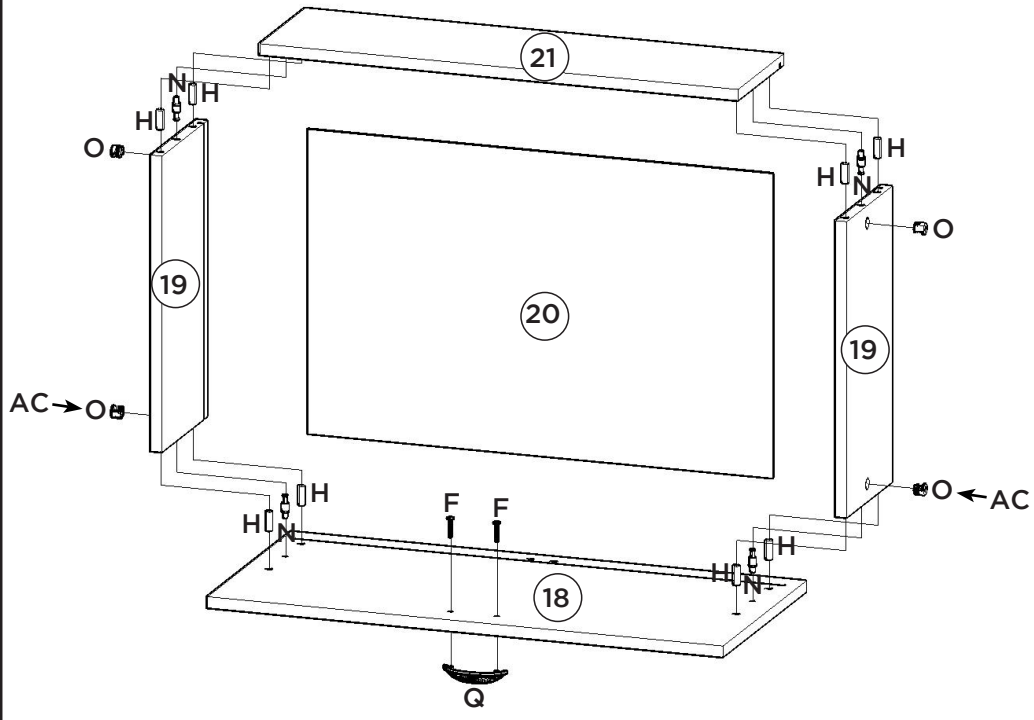









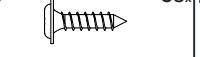

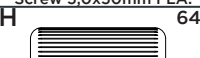
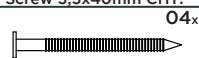
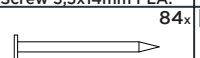
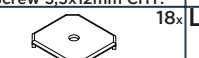

P

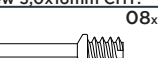
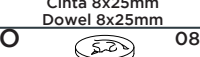

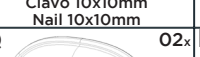
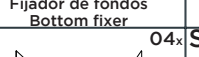
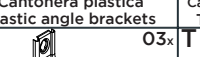
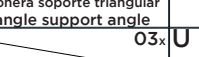
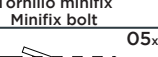
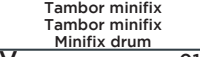
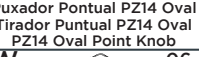
Lista de Peças | Lista de piezas | List of parts

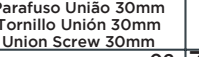
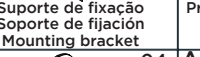
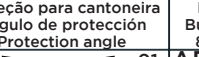
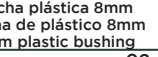
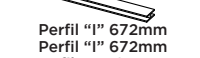
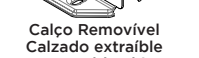
Item	Caixa Caja Box	Qtd Ctd Qty	Descrição   Descripción   Description	Medidas (mm)   Dimensiones (mm)   Size (measurements) (mm)
01	2/2	01	Rodapé Frontal   Frente pie de página   Front Footer	715x145x15
02	2/2	02	Rodapé Lateral   Pie de página Side   Side Footer	450x145x15
03	2/2	01	Rodapé Traseiro   Pie de página trasera   Rear Footer	683x145x15
04	2/2	01	Base   Base   Base	715x490x15
05	2/2	01	Lateral Esquerda Inferior   Lateral Izquierda Inferior   Left Side Lower	660x490x15
06	2/2	01	Lateral Direita Inferior   Lateral Derecha Inferior   Right Side Bottom	660x490x15
07	2/2	01	Travessa frontal   Travesaño frontal   Front crossbar	684x60x15
08	2/2	01	Travessa traseira   Travesaño trasero   Rear bumper	684x60x15
09	2/2	01	Tampo Central 25mm   Tapa Central 25mm   Central Surface 25mm	715x533x25
10	1/2	01	Lateral Esquerda Superior   Lateral Izquierda Superior   Upper Left Side	1345x295x15
11	1/2	01	Lateral Direita Superior   Lateral Derecha Superior   Right Side Superior	1345x295x15
12	2/2	04	Prateleira   Estante   Shelf	684x295x15
13	2/2	01	Tampo   Tapa   Top	715x322x15
14	2/2	01	Fundo central   Fondo central   Central fund	708x417x3
15	2/2	03	Fundo   Fondo   Bottom	708x311x3
16	1/2	02	Fundo Cru   Fondo Crudo   Raw Background	687x353x3
17	1/2	02	Porta Vidro   Puerta de cristal   Glass Door	1339x354x15
18	2/2	02	Frente de gaveta   Frente de cajón   Front of drawer	711x330x15
19	2/2	04	Lado de Gaveta   Lado del cajón   Drawer Side	400x180x15
20	2/2	02	Fundo de gaveta   Fondo de cajón   Bottom of drawer	640x411x3
21	2/2	02	Ripa de trás   Malla detrás   Rear lath	659x180x15
22	2/2	02	Ripa Estrutural Gaveta   Ripa Estructural Cajón   Drawer Structural Clamp	400x60x15

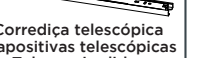
Ferragens | Herrajes | Hardware

<b>A</b> 05x  Parafuso 5,0x50mm FLA. Tornillo 5,0x50mm FLA. Screw 5,0x50mm FLA.	<b>B</b> 24x  Parafuso 3,5x40mm CHT. Tornillo 3,5x40mm CHT. Screw 3,5x40mm CHT.	<b>C</b> 58x  Parafuso 3,5x14mm FLA. Tornillo 3,5x14mm FLA. Screw 3,5x14mm FLA.	<b>D</b> 24x  Parafuso 3,5x12mm CHT. Tornillo 3,5x12mm CHT. Screw 3,5x12mm CHT.	<b>E</b> 02x  Parafuso 3,0x30mm CHT. Tornillo 3,0x30mm CHT. Screw 3,0x30mm CHT.	<b>F</b> 06x  Parafuso 4x20mm CHT. ZB Tornillo 4x20mm CHT. ZB Screw 4x20mm CHT. ZB	<b>G</b> 08x  Parafuso 3,0x16mm CHT. Tornillo 3,0x16mm CHT. Screw 3,0x16mm CHT.
<b>H</b> 64x  Cavilha 8x25mm Cinta 8x25mm Dowel 8x25mm	<b>I</b> 04x  Prego 12x12mm Anelado Clavo 12x12mm Anillado Ringed Nails 12x12mm	<b>J</b> 84x  Prego 10x10mm Clavo 10x10mm Nail 10x10mm	<b>K</b> 18x  Fixador de fundos Fijador de fondos Bottom fixer	<b>L</b> 08x  Cantoneira plástica Cantonera plástica Plastic angle brackets	<b>M</b> 08x  Cantoneira suporte triangular Cantonera soporte triangular Triangle support angle	<b>N</b> 08x  Parafuso minifix Tornillo minifix Minifix bolt
<b>O</b> 08x  Tambor minifix Tambor minifix Minifix drum	<b>P</b> 02x  Puxador Pontual PZ14 Oval Tirador Pontual PZ14 Oval PZ14 Oval Point Knob	<b>Q</b> 02x  Puxador Concha Tirador Concha Shell Handle	<b>R</b> 04x  Parafuso União 30mm Tornillo Unión 30mm Union Screw 30mm	<b>S</b> 03x  Suporte de fixação Soporte de fijación Mounting bracket	<b>T</b> 03x  Proteção para cantoneira Ángulo de protección Protection angle	<b>U</b> 05x  Buchta plástica 8mm Buchta de plástico 8mm 8mm plastic bushing
<b>V</b> 01x  Perfil "I" 672mm Perfil "I" 672mm Profile "I" 672mm	<b>W</b> 06x  Calço Removível Calzado extraíble Removable Shim	<b>X</b> 06x  Dobradica SlideOn Baja Amortecedor 35mm Bisagra SlideOn Baja Amortiguador 35mm Low SlideOn Hinge 35mm Shock Absorber	<b>Y</b> 02x  Corrediza telescópica Diapositivas telescópicas Telescopic slides	<b>Z</b> 04x  Sapata "L" 16x20mm Zapata "L" 16x20mm "L" shoe 16x20mm	<b>AA</b> 01x  Sachê de cola Bolsa de pegamento Glue bag	<b>AB</b> 02x  Giz de correção Tiza de corrección Chalk of correction
<b>AC</b> 04x  Adesivo tampa parafuso 17mm Adhesivo tapón de tornillo 17mm Bolt cover adhesive 17mm	<b>AD</b> 18x  Adesivo tampa parafuso 10mm Adhesivo tapón de tornillo 10mm Bolt cover adhesive 10mm	<b>AE</b> 04x  Parafuso 4,5x50mm CHT. Tornillo 4,5x50mm CHT. Screw 4,5x50mm CHT.	<b>AF</b> 02x  Parafuso 4,0x35mm CHT. Tornillo 4,0x35mm CHT. Screw 4,0x35mm CHT.	<b>AG</b> 01x  Etiqueta resinada Henn Etiqueta resinada Henn Henn resin label		

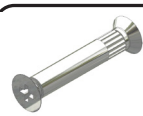

O parafuso (R) deve ser usada somente quando este módulo for acoplado a outro módulo componível Henn.

RECOMENDAÇÃO

Para fixar o móvel na parede usar o suporte de fixação (S), o parafuso 3,5x14mm FLA (C), a Bucha 8mm (U) e o parafuso 5,0x50mm FLA (A).

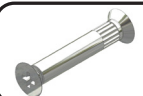

El tornillo (R) se debe utilizar sólo cuando el módulo está conectado a otro módulo componible Henn.

RECOMENDACIÓN

Para conectar el móvil a la pared con el soporte (S), tornillo 3,5 x14mm FLA (C), el casquillo de 8 mm (U) y el 5,0 x50mm tornillo FLA (A).



The screw (R) should be used only when this module is attached to another Henn modular module.

RECOMMENDATION

To fix the furniture to the wall use the mounting bracket (S), the 3.5x14mm FLA (C) screw, the 8mm bushing (U) and the 5.0x50mm FLA (A).



# INSTRUÇÕES DE MONTAGEM

## INSTRUCCIONES DE MONTAJE ASSEMBLY INSTRUCTIONS

Requisitos para montagem  
Requisitos para la montaje  
Assembly Requirements

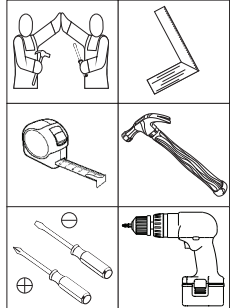

Imagens meramente ilustrativas  
Imágenes meramente ilustrativas  
Images for illustration only

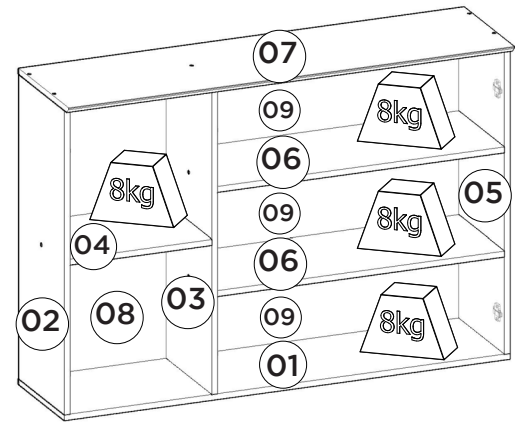
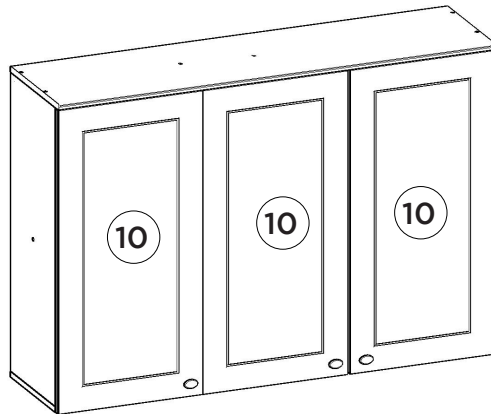

Pesos máximos recomendados com carga distribuída  
Peso máximo recomendado con la carga distribuida  
Recommended maximum weight with distributed load.

### Lista de Peças | Lista de piezas | List of parts

Item	Caixa Caja Box	Qty Ctd Qty	Descrição   Descripción   Description	Medidas (mm)   Dimensions (mm)   Size (measurements) (mm)
01	1/1	01	Base   Base   Base	1200x295x15
02	1/1	01	Lateral Esquerda   Lateral Izquierda   Right Left	800x295x15
03	1/1	01	Divisão   División   Division	800x295x15
04	1/1	01	Prateleira Menor   Estante Pequeño   Smaller Shelf	382x295x15
05	1/1	01	Lateral Direita   Lateral Derecha   Right Side	800x295x15
06	1/1	02	Prateleira   Estante   Shelf	772x295x15
07	1/1	01	Tampo   Tapa   Top	1200x322x15
08	1/1	01	Fundo Lateral   Fondo Lateral   Lateral Background	824x401x3
09	1/1	03	Fundo   Fondo   Bottom	791x274x3
10	1/1	03	Porta   Puerta   Door	813x396x15

### Ferragens | Herrajes | Hardware

<b>A</b>  Parafuso 5,0x50mm FLA. Tornillo 5,0x50mm FLA. Screw 5.0x50mm FLA.	<b>03x</b>	<b>B</b>  Parafuso 3,5x40mm CHT. Tornillo 3,5x40mm CHT. Screw 3.5x40mm CHT.	<b>16x</b>	<b>C</b>  Parafuso 3,5x14mm FLA. Tornillo 3,5x14mm FLA. Screw 3.5x14mm FLA.	<b>42x</b>	<b>D</b>  Parafuso M4x20mm CHT. ZB Tornillo M4x20mm CHT. ZB Screw M4x20mm CHT. ZB	<b>03x</b>	<b>E</b>  Cavilha 8x25mm Cinta 8x25mm Dowel 8x25mm	<b>24x</b>	<b>F</b>  Calço Removível Calzado extraíble Removable Shim	<b>06x</b>
<b>G</b>  Dobradilha SlideOn Baixa Amortecedor 35mm Bisagra SlideOn Baja Amortiguador 35mm Low SlideOn Hinge 35mm Shock Absorber	<b>06x</b>	<b>H</b>  Puxador Pontual PZ14 Oval Tirador Puntual PZ14 Oval PZ14 Oval Point Knob	<b>03x</b>	<b>I</b>  Bucha plástica 8mm Bucha de plástico 8mm 8mm plastic bushing	<b>03x</b>	<b>J</b>  Suporte de fixação Soporte de fijación Mounting bracket	<b>03x</b>	<b>K</b>  Proteção para cantoneira Ángulo de protección Protection angle	<b>03x</b>	<b>L</b>  Parafuso União 30mm Tornillo Unión 30mm Union Screw 30mm	<b>04x</b>
<b>M</b>  Giz de correção Tiza de corrección Chalk of correction	<b>02x</b>	<b>N</b>  Sachê de cola Bolsa de pegamento Glue bag	<b>02x</b>	<b>O</b>  Adesivo tapan parafuso 10mm Adhesivo tapón de tornillo 10mm Bolt cover adhesive 10mm	<b>19x</b>	<b>P</b>  Fixador de fundos Fijador de fondos Bottom fixer	<b>21x</b>	<b>Q</b>  Prego 10x10mm Clavo 10x10mm Nail 10x10mm	<b>66x</b>	<b>R</b>  Etiqueta resinada Henn Etiqueta resinada Henn Henn resin label	<b>01x</b>

O parafuso (L) deve ser usada somente quando este módulo for acoplado a outro módulo componível Henn.

El tornillo (L) se debe utilizar sólo cuando el módulo está conectado a otro módulo componible Henn.

The screw (L) should be used only when this module is attached to another Henn modular module.

#### RECOMENDAÇÃO

Para fixar o móvel na parede usar o suporte de fixação (J), o parafuso 3,5x14mm FLA (C), a Bucha 8mm (I) e o parafuso 5,0x50mm FLA (A).

#### RECOMENDACIÓN

Para conectar el móvil a la pared con el soporte (J), tornillo 3,5 x14mm FLA (C), el casquillo de 8 mm (I) y el 5,0 x50mm tornillo FLA (A).

#### RECOMMENDATION

To fix the furniture to the wall use the fixing bracket (J), the 3.5x14mm FLA (C) screw, the 8mm bushing (I) and the 5.0x50mm FLA screw (A).

1º

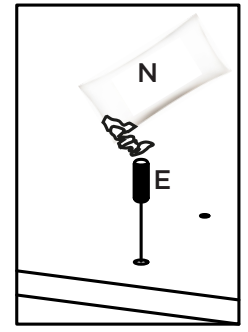
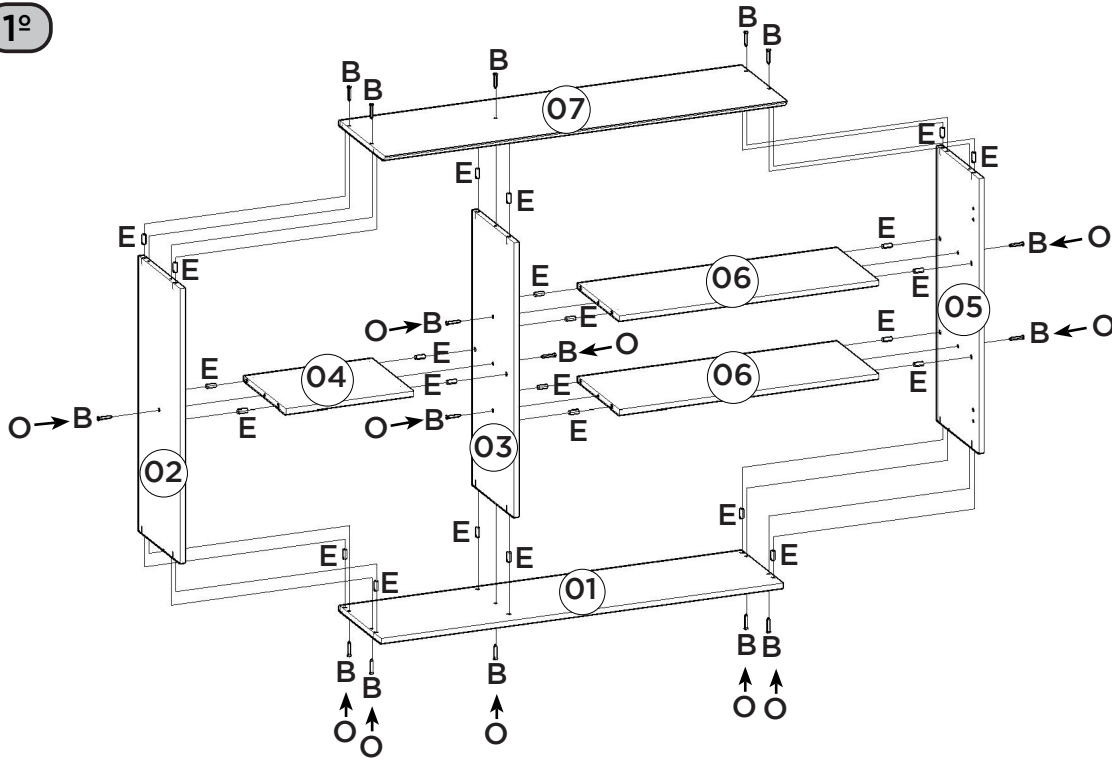

Utilizar o sachê de cola (N) em todas as cavilhas (E) do produto.

Con el pegamento sobre (N) en todos los pernos (E) producto.

Use the glue sachet (N) on all the pegs (E) of the product.

2º

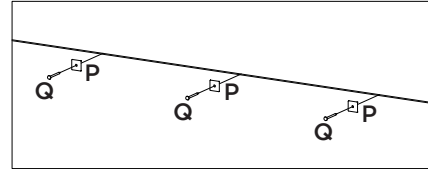
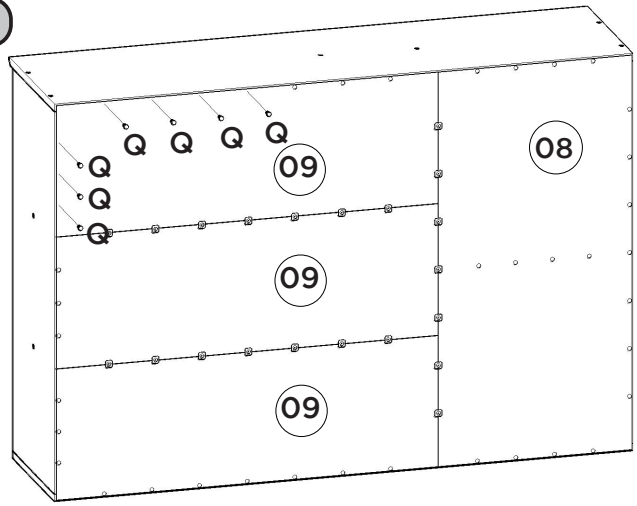

**AVISO**  
Para limpeza de seu móvel, use uma flanela seca ou umedecida, e não utilize produtos químicos que possam danificar seu produto.

**SISTEMA DE MONTAGEM**  
O sistema de montagem dos produtos, funciona de acordo com a ordem crescente dos números indicados no desenho. Ex: 01, 02, 03, 04... até a conclusão da montagem.

**ADVERTENCIA**  
Para limpeza de su móbil, use una flanela seca o húmeda, y no utilice productos químicos que puedan dañar su producto.

3º

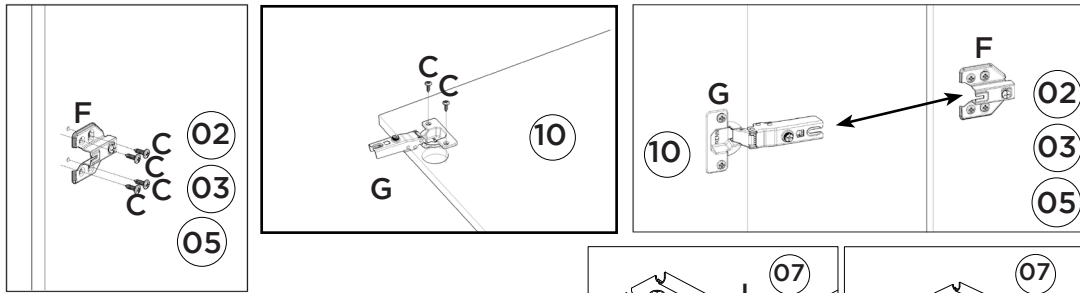

**SISTEMA DE MONTAJE**  
El sistema de montaje de los productos funciona de acuerdo con el orden creciente de los números indicados en el dibujo. Ej.: 01, 02, 03, 04... hasta la conclusión del montaje.

**NOTICE**  
To clean your furniture, use a dry or wet cloth, and do not use chemicals that may damage your product.

**ASSEMBLY SYSTEM**  
The products' assembly system works according to the increasing order of the indicated numbers. For example: 01, 02, 03, 04 ... to the end of the assembly.

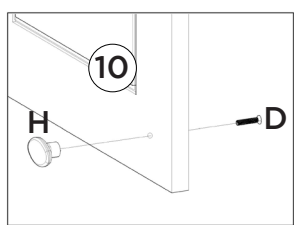
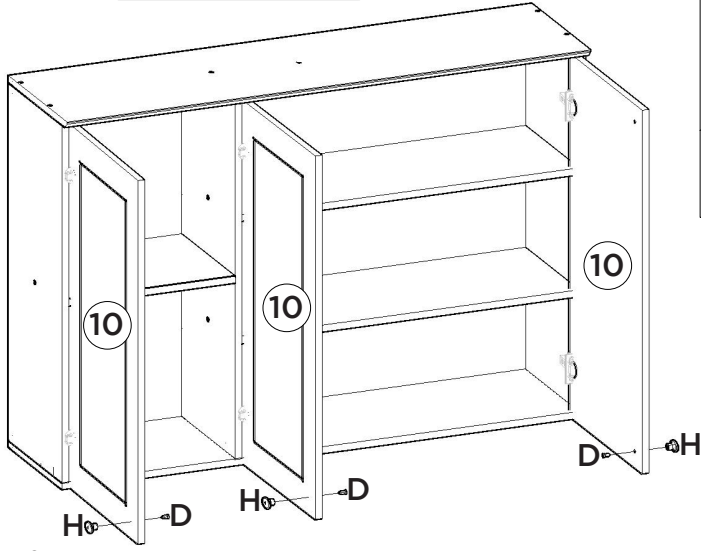

Para colocação dos puxadores, é necessário fazer a furação passante, com Broca de 5mm.

Para la colocación de las asas, es necesario perforar a través, con una broca de 5mm.

To place the handles is necessary to make the through hole, drill 5mm.

# INSTRUÇÕES DE MONTAGEM

## INSTRUCCIONES DE MONTAJE ASSEMBLY INSTRUCTIONS

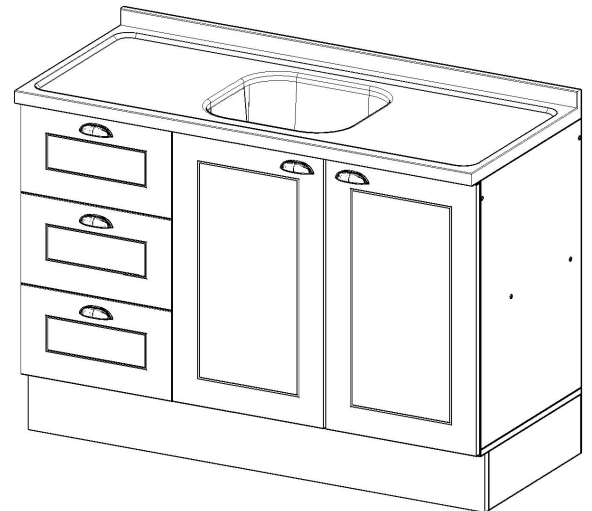
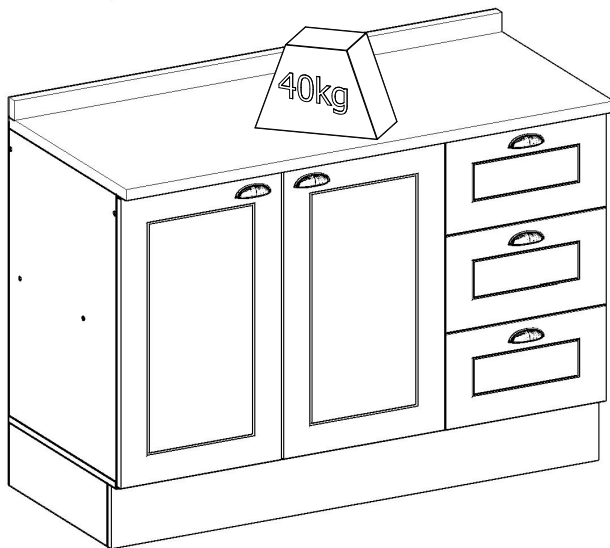
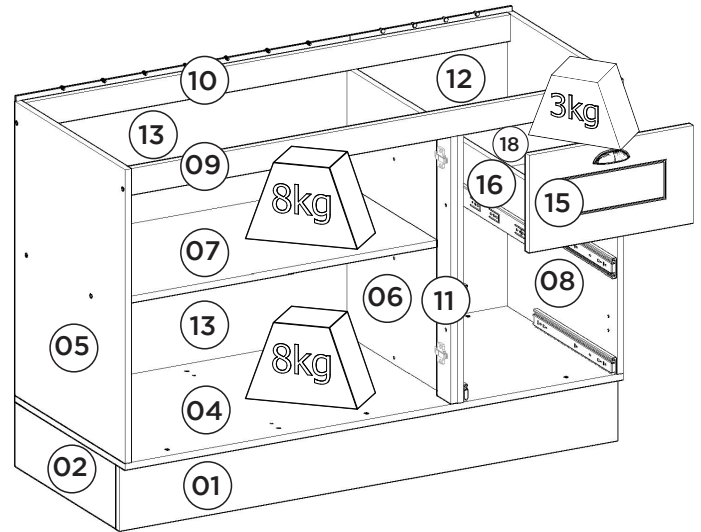
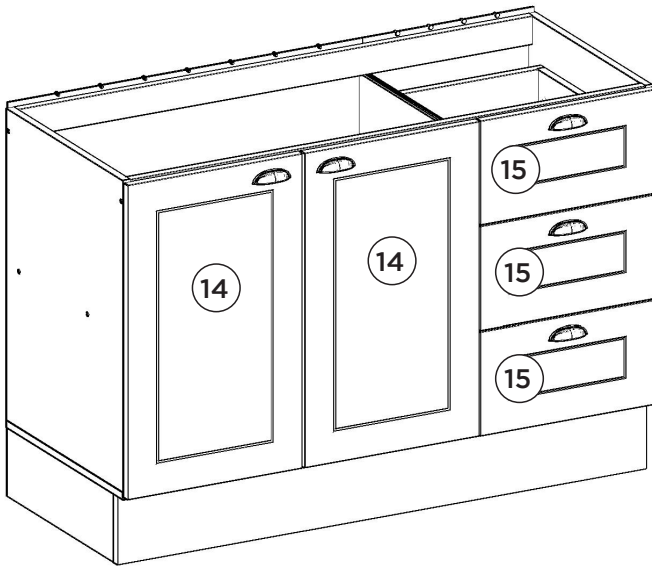

Pesos máximos recomendados com carga distribuída  
Peso máximo recomendado con la carga distribuida  
Recommended maximum weights with evenly distributed.

### Requisitos para montagem Requisitor para la montaje Assembly Requirements

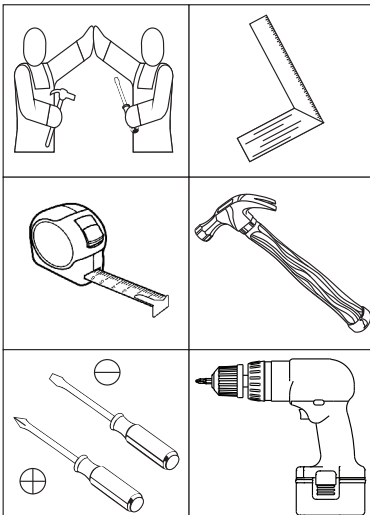

Imagens meramente ilustrativas  
Imágenes meramente ilustrativas  
Images for illustration only

### AVISO

Para limpeza de seu móvel, use uma flanela seca ou umedecida, e não utilize produtos químicos que possam danificar seu produto.

### SISTEMA DE MONTAGEM

O sistema de montagem dos produtos, funciona de acordo com a ordem crescente dos números indicados no desenho. Ex: 01, 02, 03, 04... até a conclusão da montagem.

### ADVERTENCIA

Para limpieza de su móvil, use una flanela seca o húmeda, y no utilice productos químicos que puedan dañar su producto.

### SISTEMA DE MONTAJE

El sistema de montaje de los productos funciona de acuerdo con el orden creciente de los números indicados en el dibujo. Ej.: 01, 02, 03, 04... hasta la conclusión del montaje.

### NOTICE

To clean your furniture, use a dry or wet cloth, and do not use chemicals that may damage your product.

### ASSEMBLY SYSTEM

The products' assembly system works according to the increasing order of the indicated numbers. For example: 01, 02, 03, 04 ... to the end of the assembly.

1º

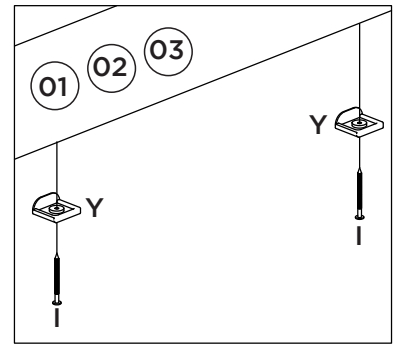
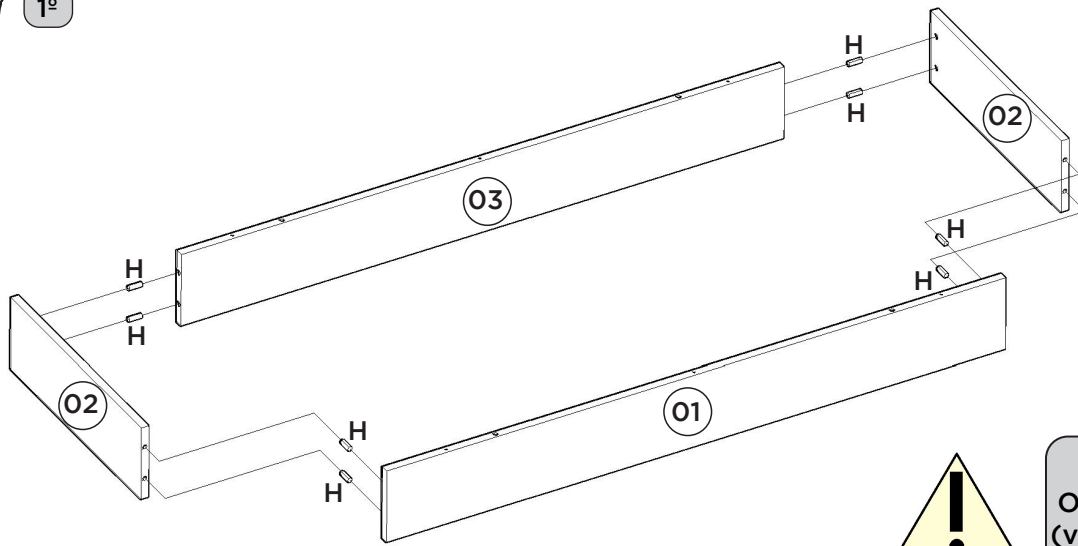

**OPCIONAL:**  
O945-121 Kit Pé Cônico 145mm (vendido separadamente). Caso opte em colocar pé no produto, utilizar as pré-furações que possui na Base e fixá-lo com o Parafuso que consta no Kit.

**OPCIONAL:**  
O945-121 Kit Pie Cónico 145mm (se vende por separado). Si opta por colocar pie en el producto, utilizar las pre-huracuras que tenga en la Base y fijarlo con el Tornillo que consta en el Kit.

**OPTIONAL:**  
O945-121 Tapered Foot Kit 145mm (sold separately). If you choose to put foot in the product, use the pre-drillings in the Base and fix it with the Screw included in the Kit.

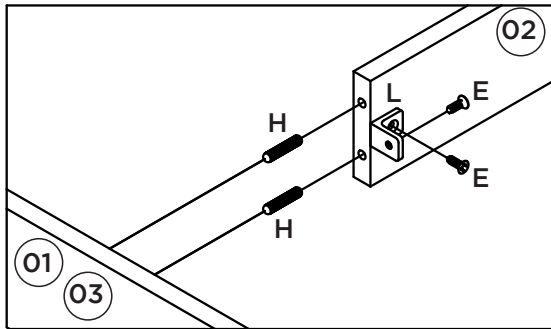

2º

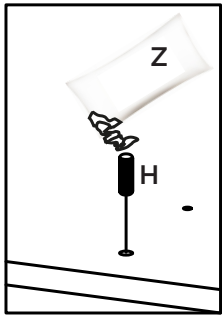

Utilizar o sachê de cola (Z) em todas as cavilhas (H) do produto.

Con el pegamento sobre (Z) en todos los pernos (H) producto.

Use the glue sachet (Z) on all the pegs (H) of the product.

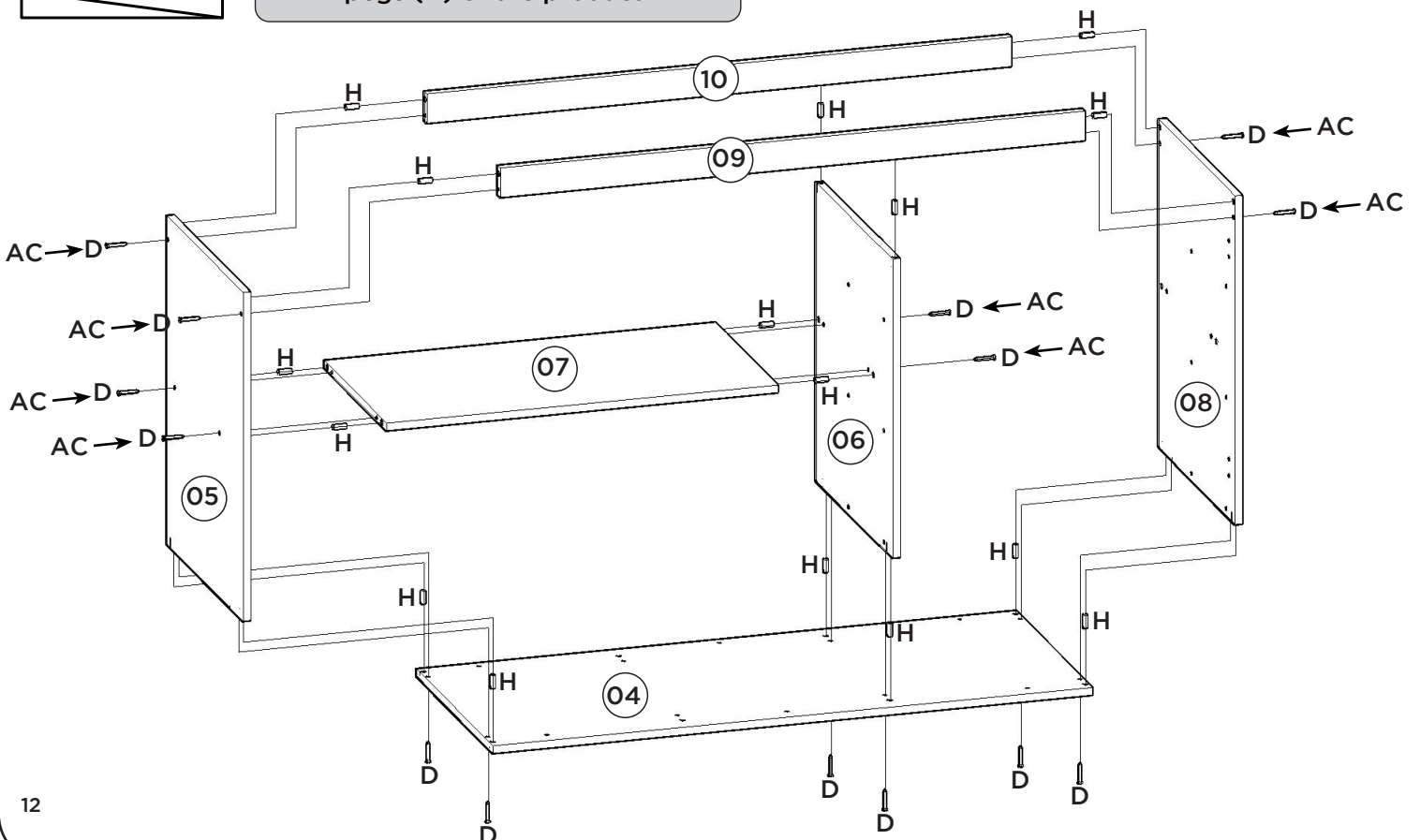

3º

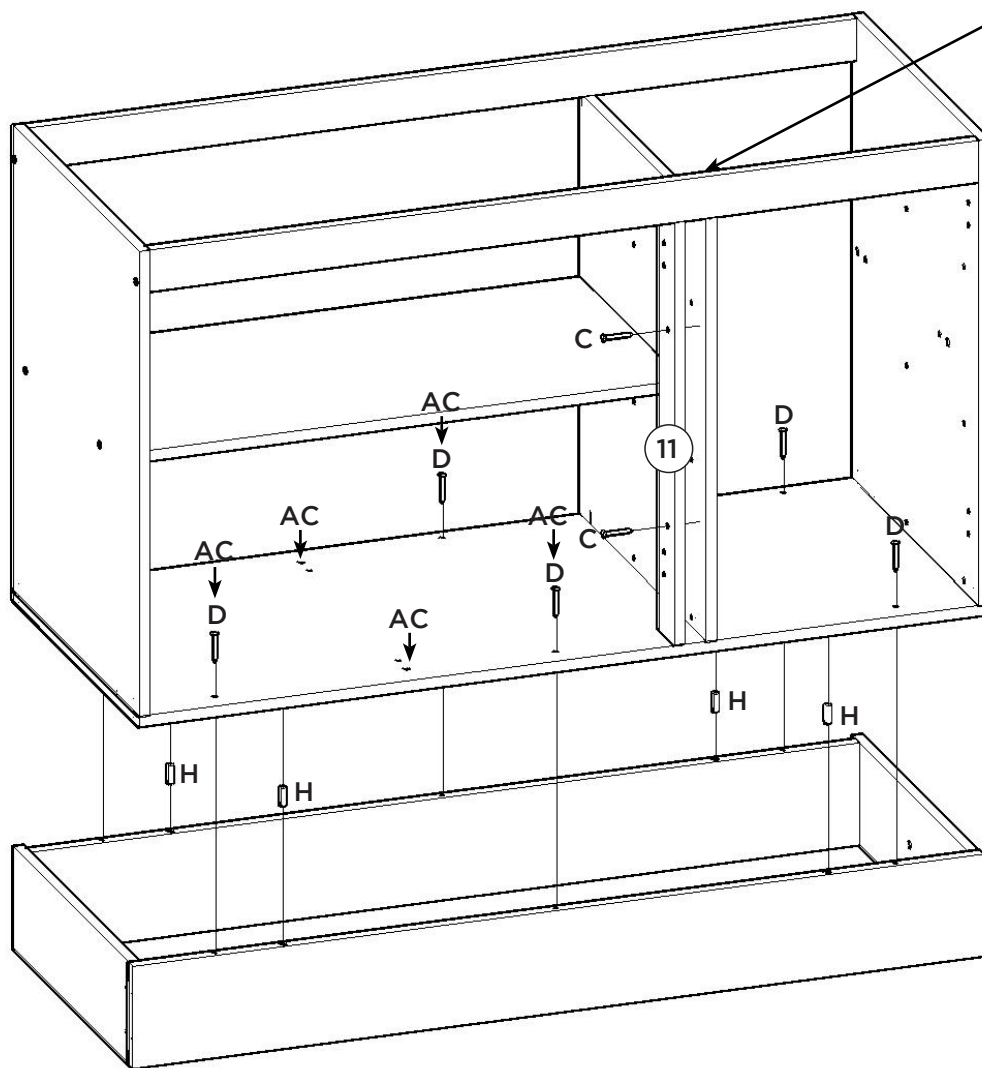

A pilastra da porta (11) deve estar alinhada com a divisão (06).

El pilar de la puerta (11) debe estar alineada con la división (06).

The door pillar (11) must be aligned with the partition (06).

4º

Esse tampo é opcional e é vendido separadamente (C905-114).

Esta vez es opcional y se vende por separado (C905-114).

This top is optional and is sold separately (C905-114).

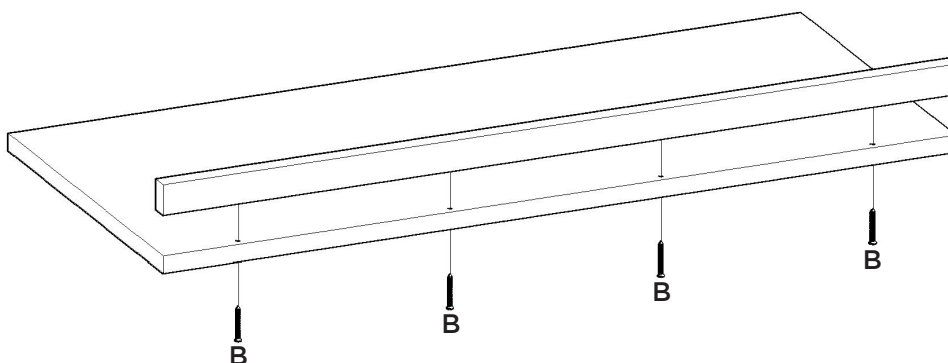

5°

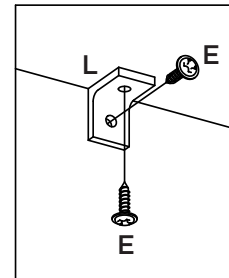
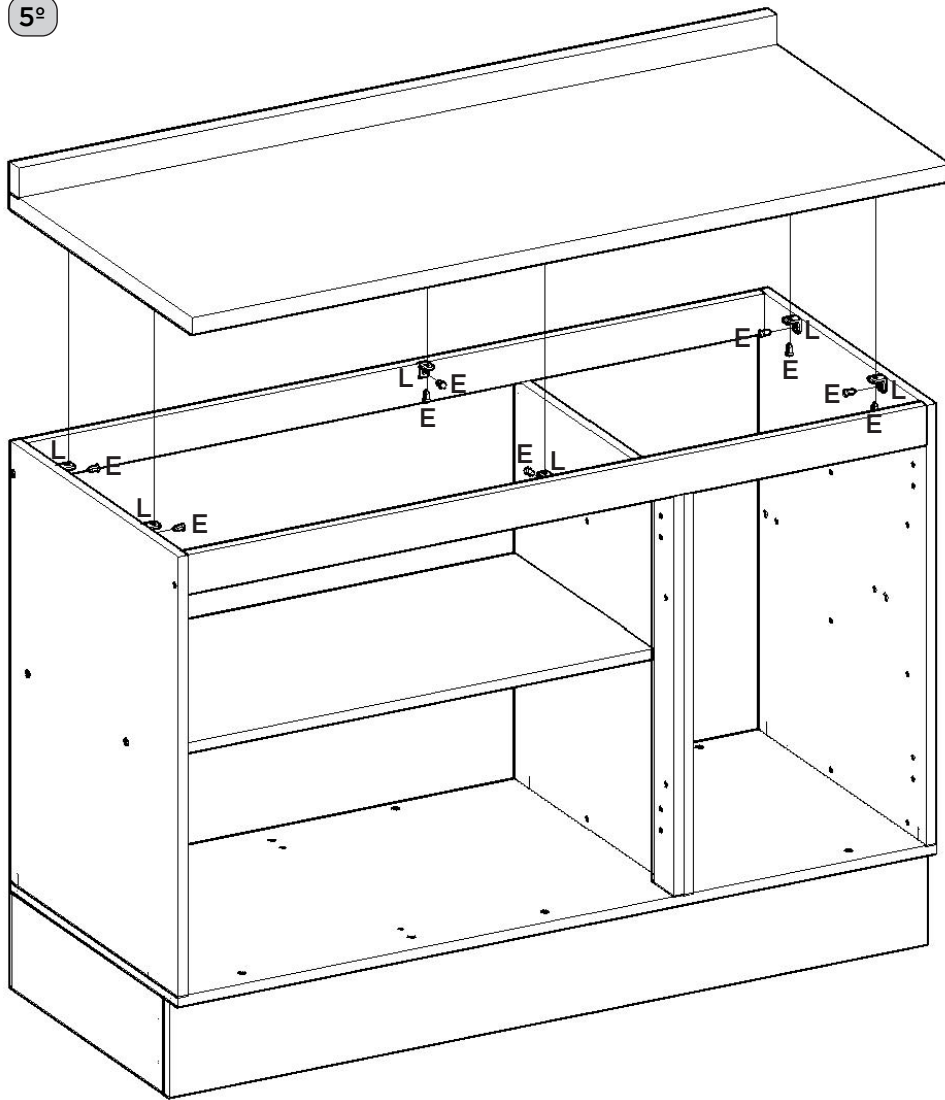

Caso o móvel seja montado com a opção do tampo, fixar o mesmo com 06 cantoneiras (L) e os parafusos 3,5x14mm (E).

Si se monta el auricular con la opción de la cubierta, fijarlo con Los ángulos 06 (L) y 3,5 x14mm tornillos (E).

If the furniture is to be installed with the top cover option, fix it with 06 (L) and 3.5x14mm screws (E).

6°

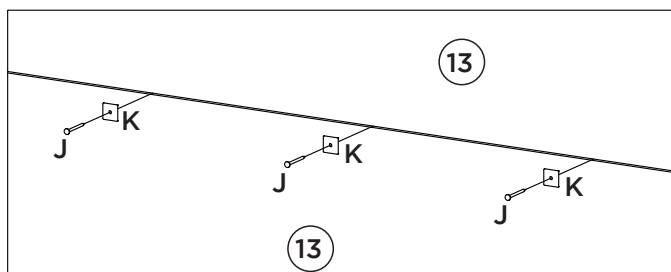
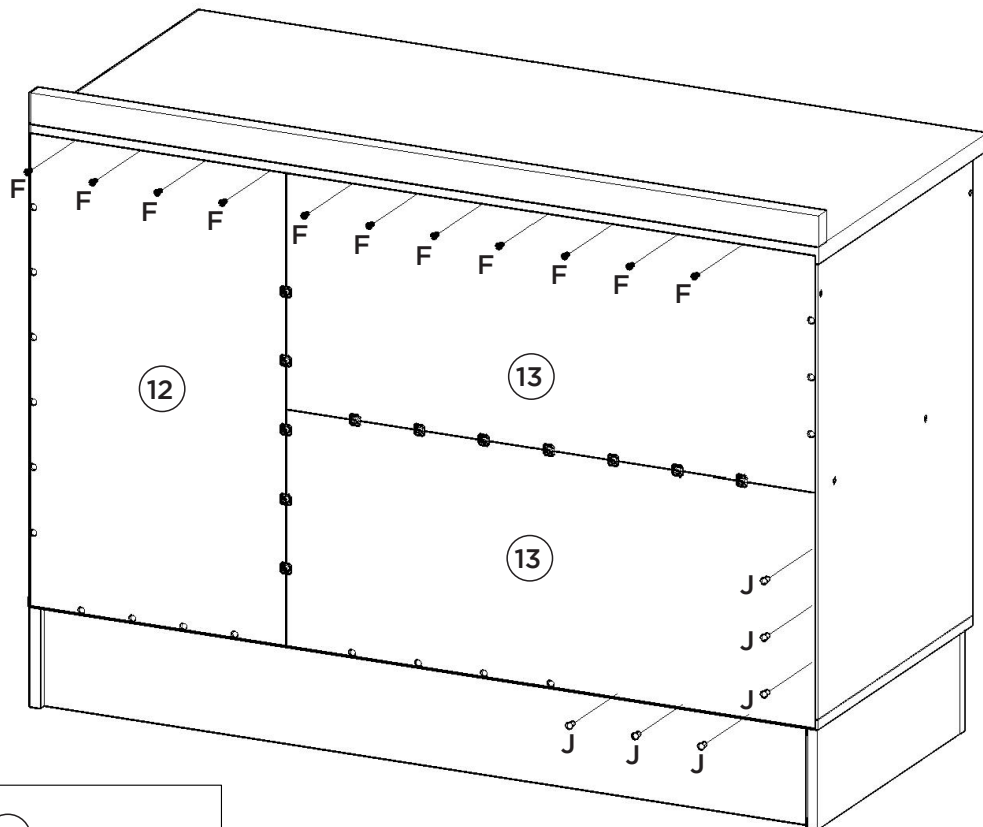
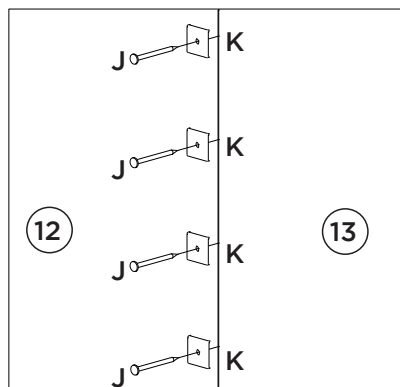

14

7º

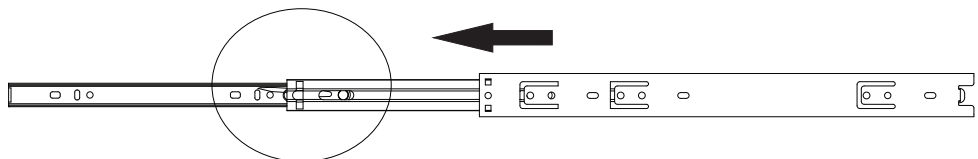
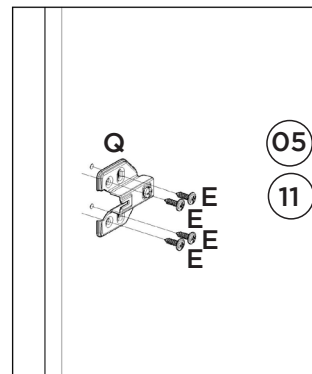
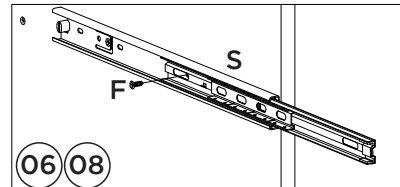
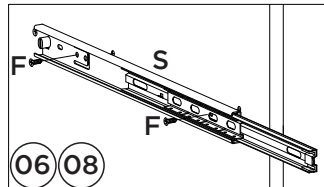
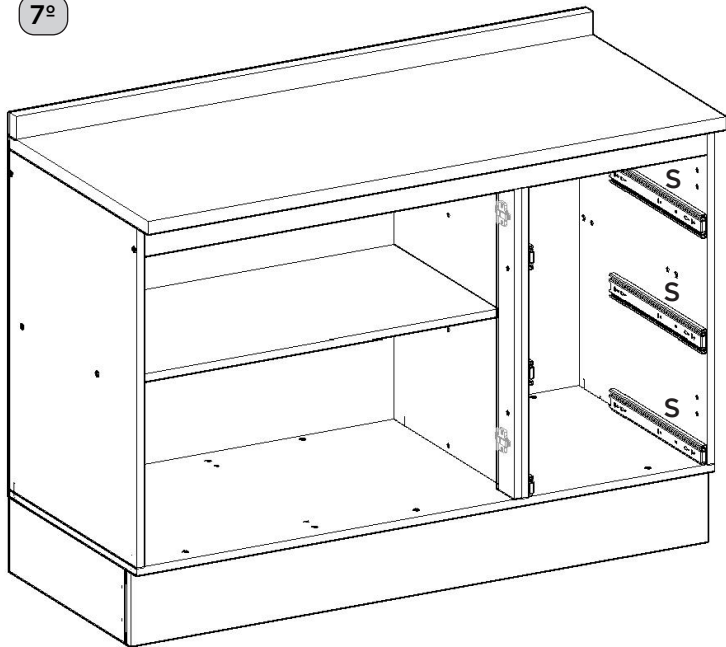

Para a desmontagem da correia siga a instrução ao lado.

Para el desmontaje seguimiento de diapositivas la instrucción siguiente a.

For the dismount of the sliding onem follows the instruction aside.

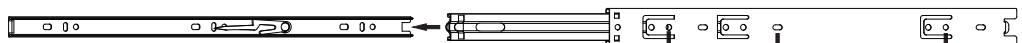
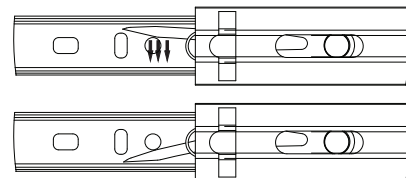

Fixar as correias nessas furações  
Fijar las diapositivas de estos agujeros  
Fix slides in these drillings

8º

Opção Suspensa

Opción suspendida

Suspended Option

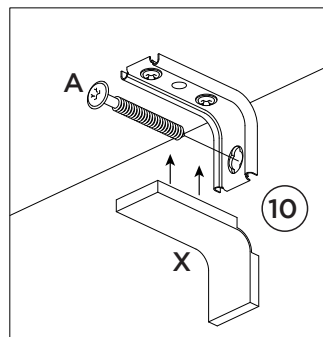
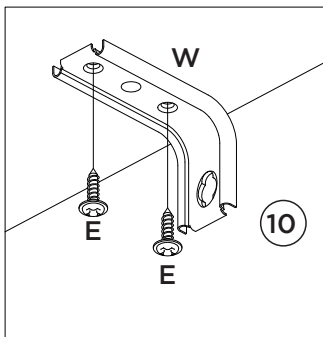

Parede  
pared  
Wall

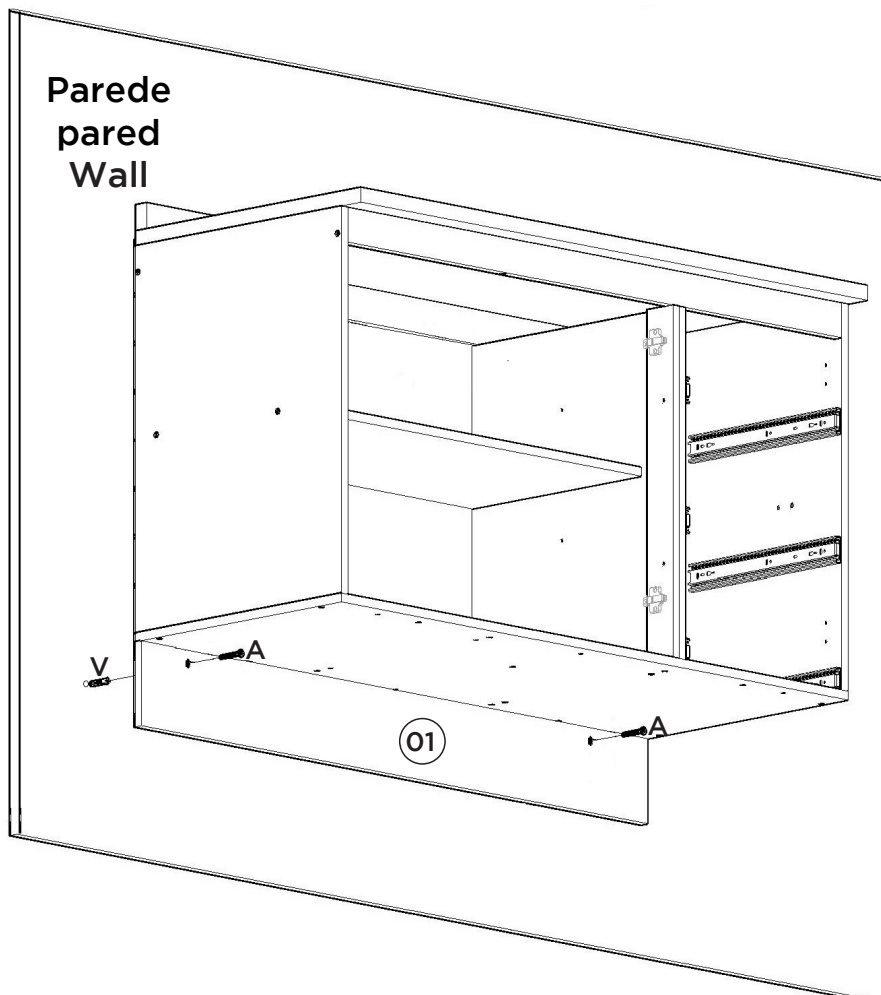

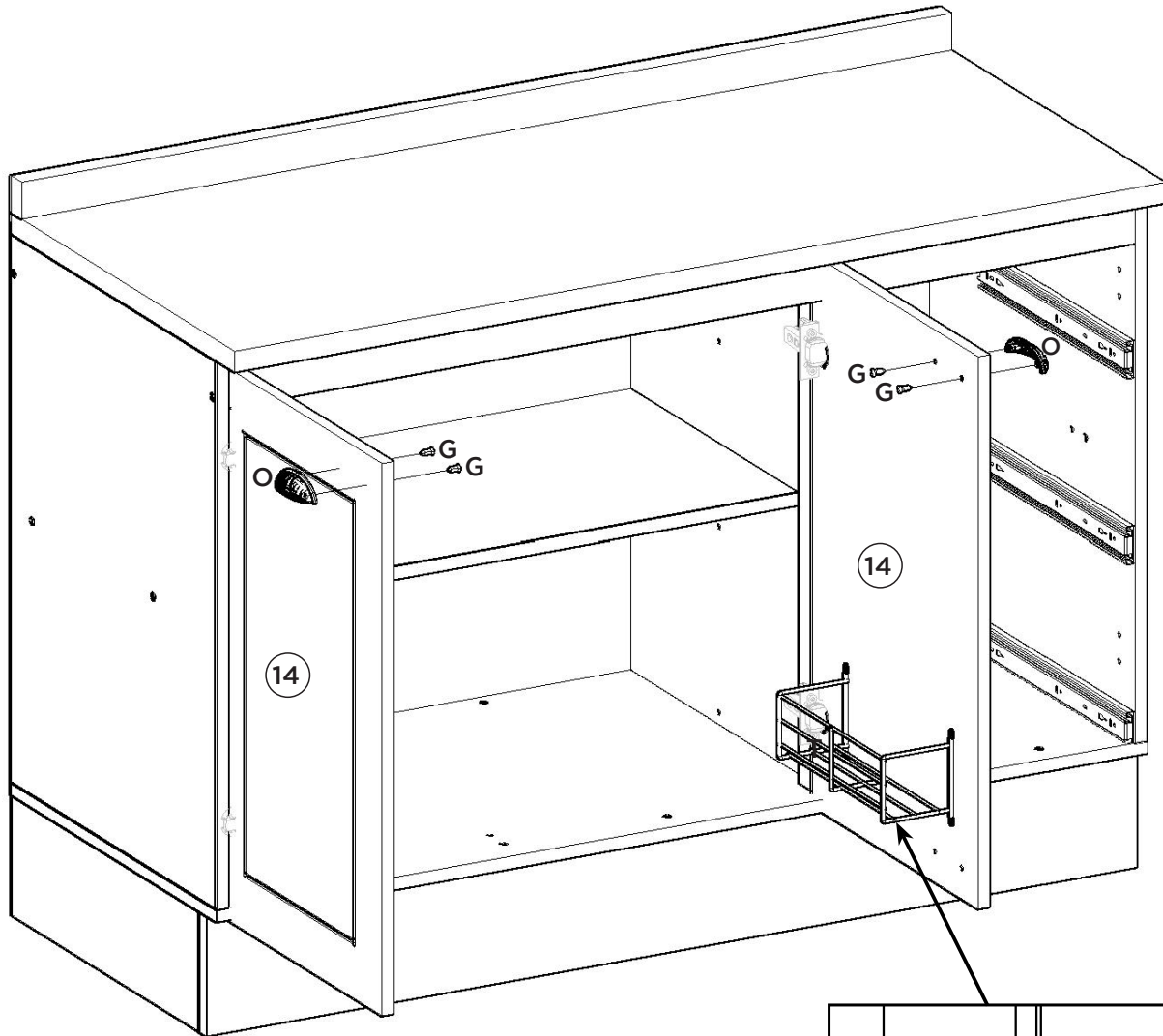
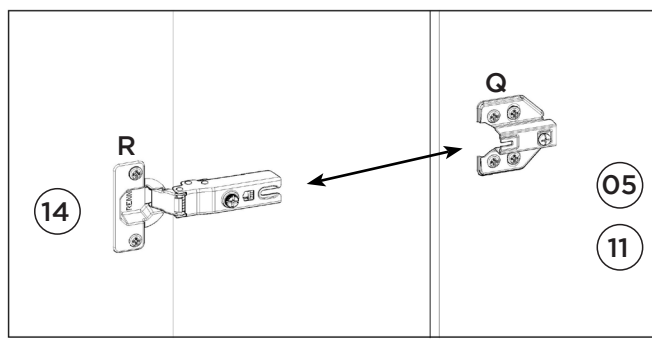
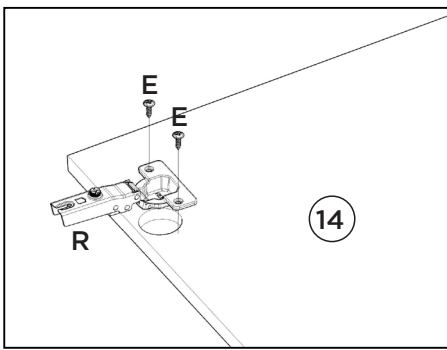

Para colocação dos puxadores, é necessário fazer a furação passante, com Broca de 5mm.

Para la colocación de las asas, es necesario perforar a través, con una broca de 5mm.

To place the handles is necessary to make the through hole, drill 5mm.

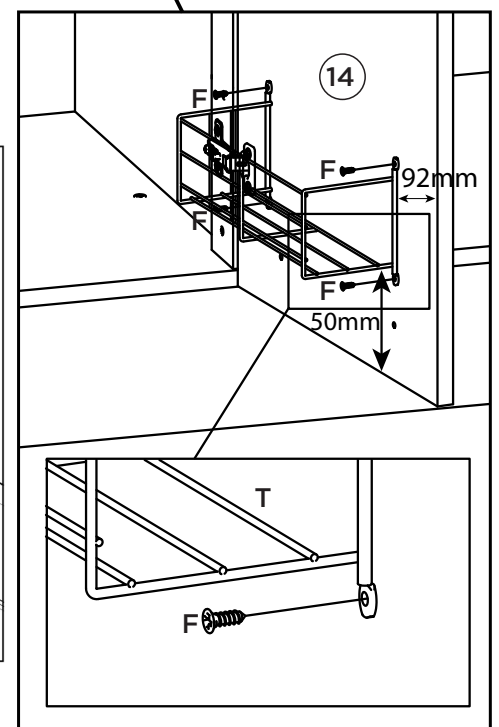
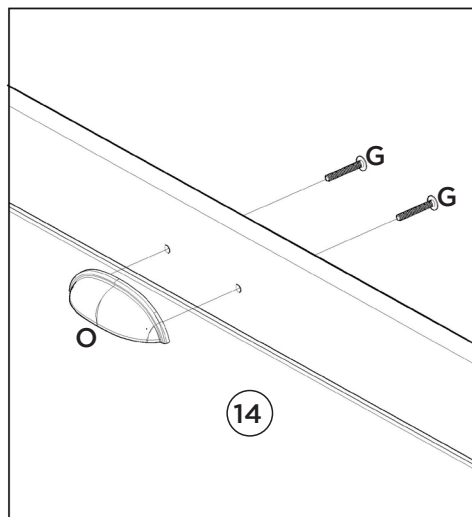



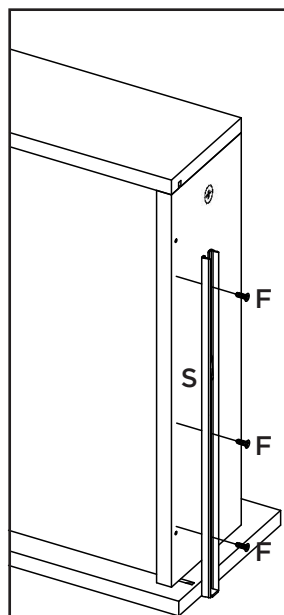
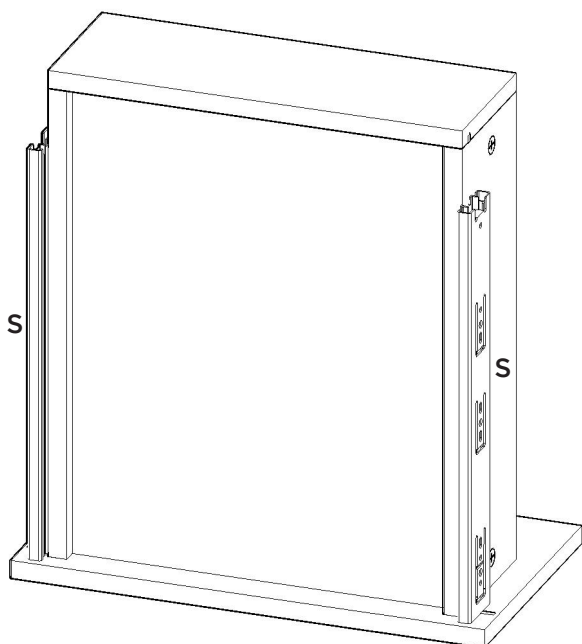
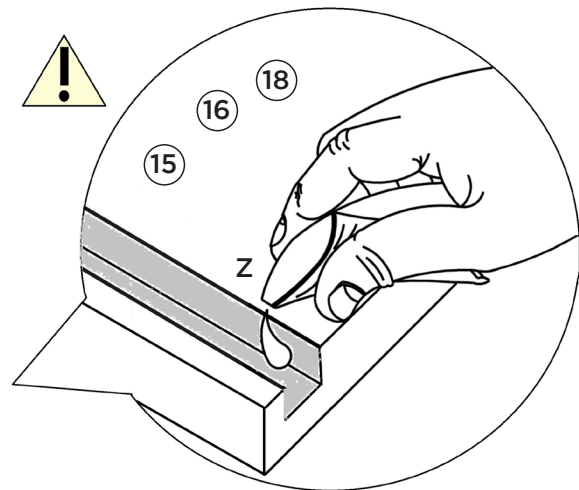
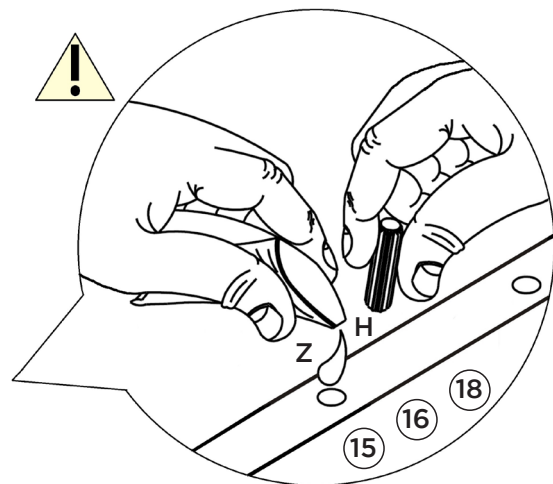
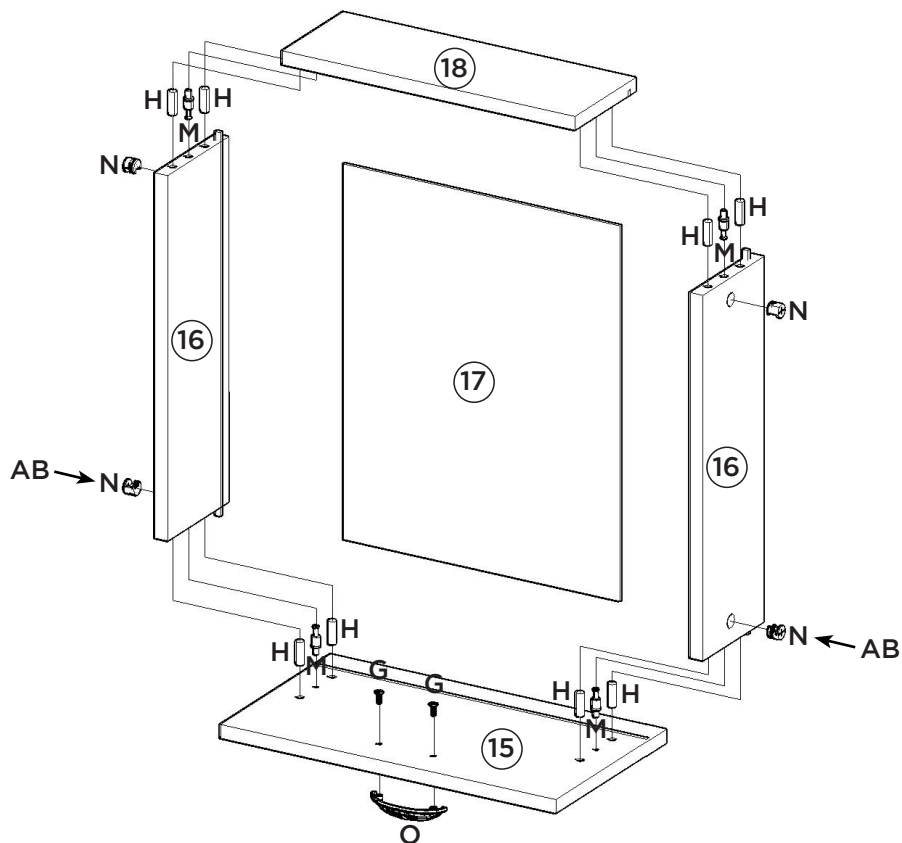

A corredeira (S) deverá ser alinhada com a parte de baixo do lado de gaveta (16).











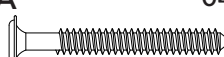
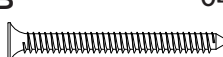







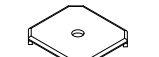

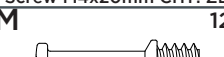
La carcasa (S) será alineada con la parte de por el lado del cajón (16).

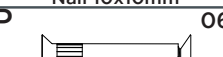
The slide (S) should be aligned with the underside of the drawer side (16).

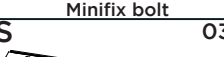
Lista de Peças | Lista de piezas | List of parts

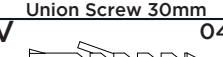
Item	Caixa Caja Box	Qty Ctd Qty	Descrição   Descripción   Description	Medidas (mm)   Dimensions (mm)   Size (measurements) (mm)
01	1/1	01	Rodapé Frontal   Frente pie de página   Front Footer	1200x145x15
02	1/1	02	Rodapé Lateral   Pie de página Side   Side Footer	450x145x15
03	1/1	01	Rodapé Traseiro   Pie de página trasera   Rear Footer	1168x145x15
04	1/1	01	Base   Base   Base	1200x490x15
05	1/1	01	Lateral esquerda   Lateral izquierda   Left side	660x490x15
06	1/1	01	Divisão   División   Division	600x490x15
07	1/1	01	Prateleira   Estante   Shelf	784x400x15
08	1/1	01	Lateral direita   Lateral derecha   Right side	660x490x15
09	1/1	01	Travessa frontal   Travesaño frontal   Front crossbar	1169x60x15
10	1/1	01	Travessa traseira   Travesaño trasero   Rear bumper	1169x60x15
11	1/1	01	Pilastra da Porta   Pilastra Puerta   Pilaster door	599x60x15
12	1/1	01	Fundo Lateral   Fondo Lateral   Lateral Background	683x389x3
13	1/1	02	Fundo   Fondo   Bottom	803x341x3
14	1/1	02	Porta   Puerta   Door	665x396x15
15	1/1	03	Frente de gaveta   Frente de cajón   Front of drawer	396x220x15
16	1/1	06	Lado de Gaveta   Lado del cajón   Drawer Side	400x122x15
17	1/1	03	Fundo de gaveta   Fondo de cajón   Bottom of drawer	411x326x3
18	1/1	03	Ripa de trás   Malla detrás   Rear lath	345x122x15

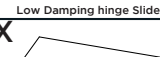
Ferragens | Herrajes | Hardware

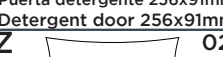
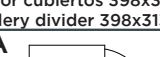
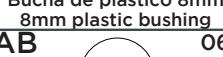
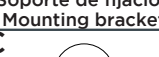
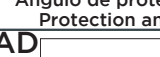
<b>A</b>  Parafuso 5,0x50mm FLA. Tornillo 5,0x50mm FLA. Screw 5,0x50mm FLA.	<b>B</b>  Parafuso 4,5x50mm CHT. Tornillo 4,5x50mm CHT. Screw 4,5x50mm CHT.	<b>C</b>  Parafuso 4,0x25mm CHT. Tornillo 4,0x25mm CHT. Screw 4,0x25mm CHT.	<b>D</b>  Parafuso 3,5x40mm CHT. Tornillo 3,5x40mm CHT. Screw 3,5x40mm CHT.	<b>E</b>  Parafuso 3,5x14mm FLA. Tornillo 3,5x14mm FLA. Screw 3,5x14mm FLA.	<b>F</b>  Parafuso 3,5x12mm CHT. Tornillo 3,5x12mm CHT. Screw 3,5x12mm CHT.
<b>G</b>  Parafuso M4x20mm CHT. ZB Tornillo M4x20mm CHT. ZB Screw M4x20mm CHT. ZB	<b>H</b>  Cavilha 8x25mm Cinta 8x25mm Dowel 8x25mm	<b>I</b>  Prego 12x12mm Anelado Clavo 12x12mm Anillado Ringed Nails 12x12mm	<b>J</b>  Prego 10x10mm Clavo 10x10mm Nail 10x10mm	<b>K</b>  Fixador de fundos Fijador de fondos Bottom fixer	<b>L</b>  Cantoneira plástica Cantонера plástica Plastic angle brackets
<b>M</b>  Parafuso minifix Tornillo minifix Minifix bolt	<b>N</b>  Tambor minifix Tambor minifix Minifix drum	<b>O</b>  Puxador Concha Tirador Concha Shell Handle	<b>P</b>  Parafuso União 30mm Tornillo Unión 30mm Union Screw 30mm	<b>Q</b>  Calço Removível Calzado extraíble Removable Shim	<b>R</b>  Dobradiça SlideOn Baixa Amortecimento 35mm Bisagra SlideOn Baja Amortiguación 35mm Low Damping hinge SlideOn 35mm
<b>S</b>  Corrediça telescópica Diapositivas telescópicas Telescopic slides	<b>T</b>  Porta detergente 256x91mm Puerta detergente 256x91mm Detergent door 256x91mm	<b>U</b>  Divisor talheres 398x313mm Divisor cubiertos 398x313mm Cutlery divider 398x313mm	<b>V</b>  Buchá plástica 8mm Buchá de plástico 8mm 8mm plastic bushing	<b>W</b>  Suporte de fixação Soporte de fijación Mounting bracket	<b>X</b>  Proteção para cantoneira Ángulo de protección Protection angle
<b>Y</b>  Sapata "L" 16x20mm Zapata "L" 16x20mm "L" shoe 16x20mm	<b>Z</b>  Sachê de cola Bolsa de pegamento Glue bag	<b>AA</b>  Giz de correção Tiza de corrección Chalk of correction	<b>AB</b>  Adesivo tapa parafuso 17mm Adhesivo tapón de tornillo 17mm Bolt cover adhesive 17mm	<b>AC</b>  Adesivo tapa parafuso 10mm Adhesivo tapón de tornillo 10mm Bolt cover adhesive 10mm	<b>AD</b>  Etiqueta resinada Henn Etiqueta resinada Henn Henn resin label

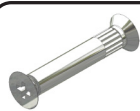

O parafuso (P) deve ser usada somente quando este módulo for acoplado a outro módulo componível Henn.

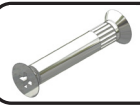

El tornillo (P) se debe utilizar sólo cuando el módulo está conectado a otro módulo componible Henn.



The screw (P) should be used only when this module is attached to another Henn modular module.

RECOMENDAÇÃO

Para fixar o móvel na parede usar o suporte de fixação (W), o parafuso 3,5x14mm FLA (E), a Bucha 8mm (V) e o parafuso 5,0x50mm FLA (A).

RECOMENDACIÓN

Para conectar el móvil a la pared con el soporte (W), tornillo 3,5 x14mm FLA (E), el casquillo de 8 mm (V) y el 5,0 x50mm tornillo FLA (A).

RECOMMENDATION

To fix the furniture to the wall use the mounting bracket (W), the 3.5x14mm FLA (E) screw, the 8mm bushing (V) and the 5.0x50mm FLA screw (A).

# INSTRUÇÕES DE MONTAGEM

## INSTRUCCIONES DE MONTAJE ASSEMBLY INSTRUCTIONS

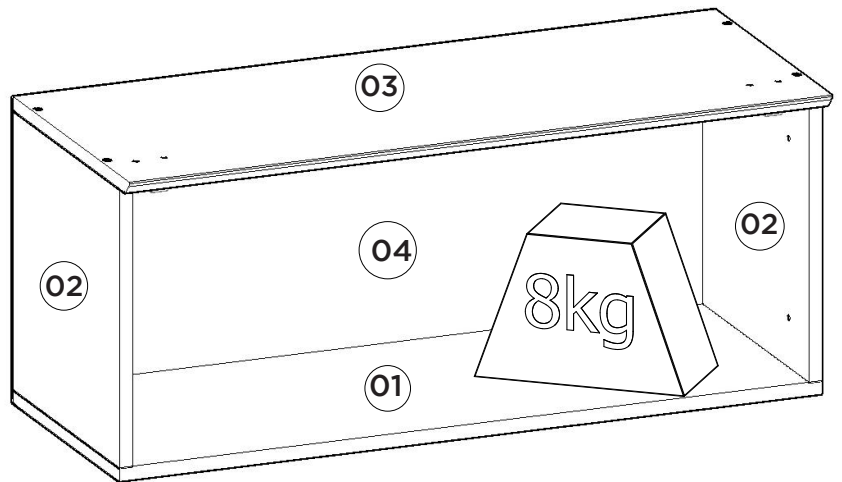
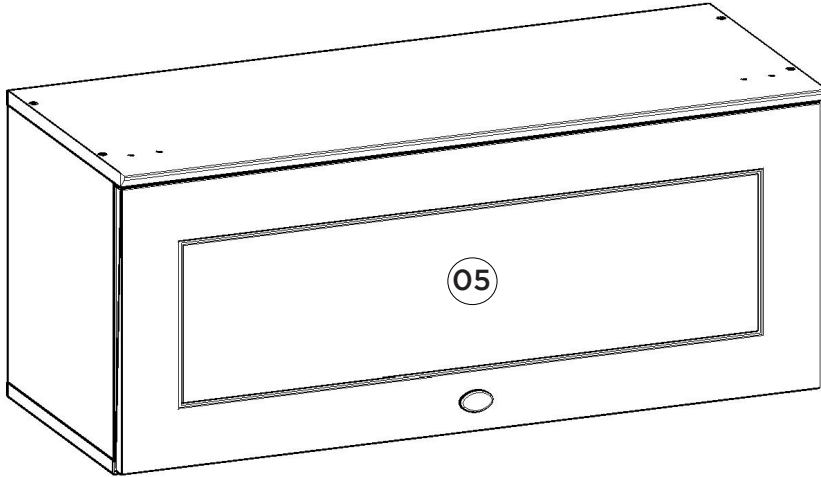

Pesos máximos recomendados com carga distribuída  
Peso máximo recomendado con la carga distribuida  
Recommended maximum weight with distributed load.

### Requisitos para montagem Requisitos para la montaje Assembly Requirements

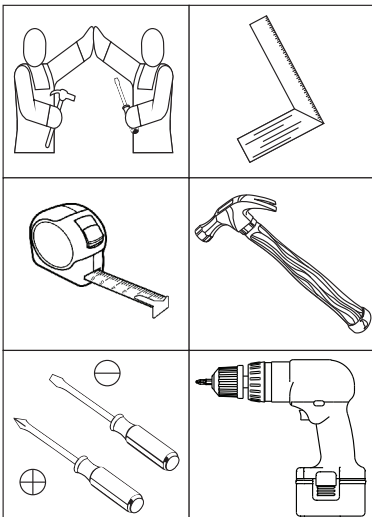

Imagens meramente ilustrativas  
Imágenes meramente ilustrativas  
Images for illustration only

### AVISO

Para limpeza de seu móvel, use uma flanela seca ou umedecida, e não utilize produtos químicos que possam danificar seu produto.

### SISTEMA DE MONTAGEM

O sistema de montagem dos produtos, funciona de acordo com a ordem crescente dos números indicados no desenho. Ex: 01, 02, 03, 04... até a conclusão da montagem.

### ADVERTENCIA

Para limpieza de su móvil, use una flanela seca o húmeda, y no utilice productos químicos que puedan dañar su producto.

### SISTEMA DE MONTAJE

El sistema de montaje de los productos funciona de acuerdo con el orden creciente de los números indicados en el dibujo. Ej.: 01, 02, 03, 04... hasta la conclusión del montaje.

### NOTICE

To clean your furniture, use a dry or wet cloth, and do not use chemicals that may damage your product.

### ASSEMBLY SYSTEM

The products' assembly system works according to the increasing order of the indicated numbers. For example: 01, 02, 03, 04 ... to the end of the assembly.

1°

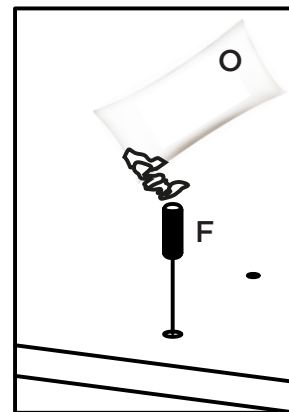
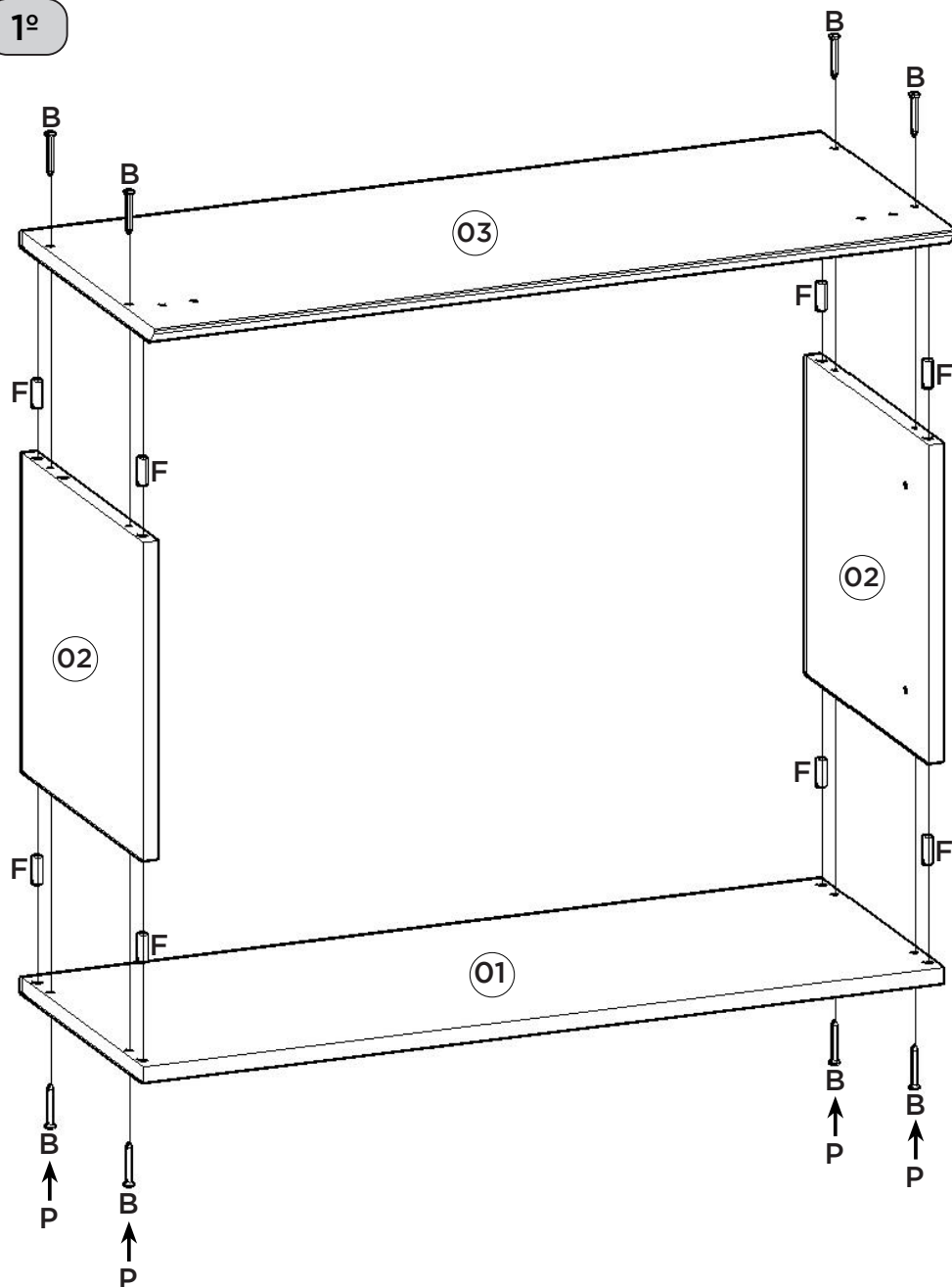

Utilizar o sachê de cola (O) em todas as cavilhas (F) do produto.

Con el pegamento sobre (O) en todos los pernos (F) producto.

Use the glue sachet (O) on all the pegs (F) of the product.

2°

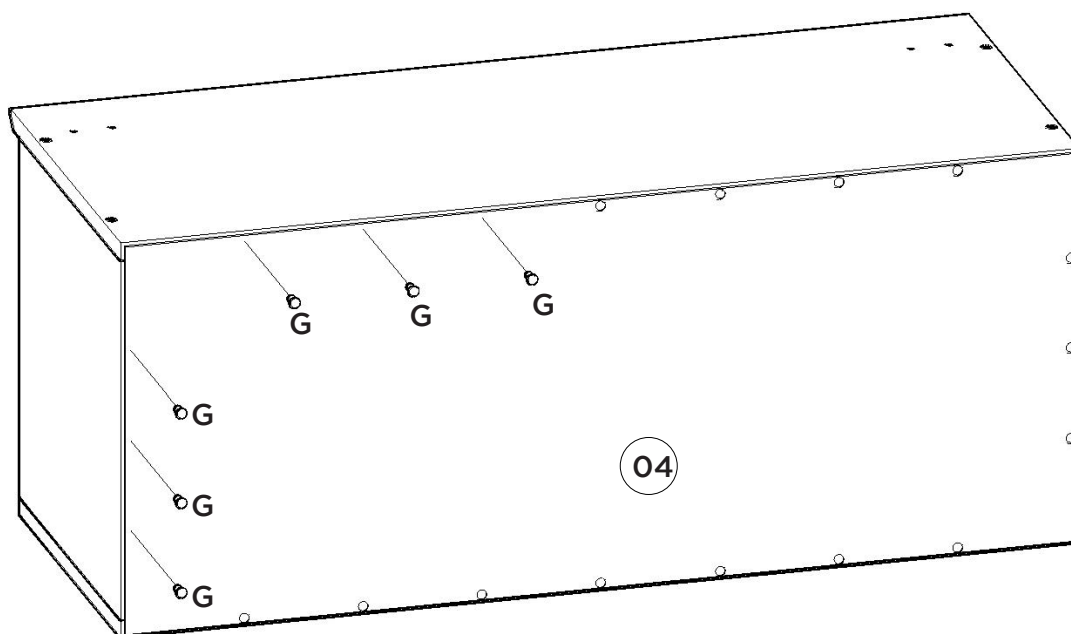

3°

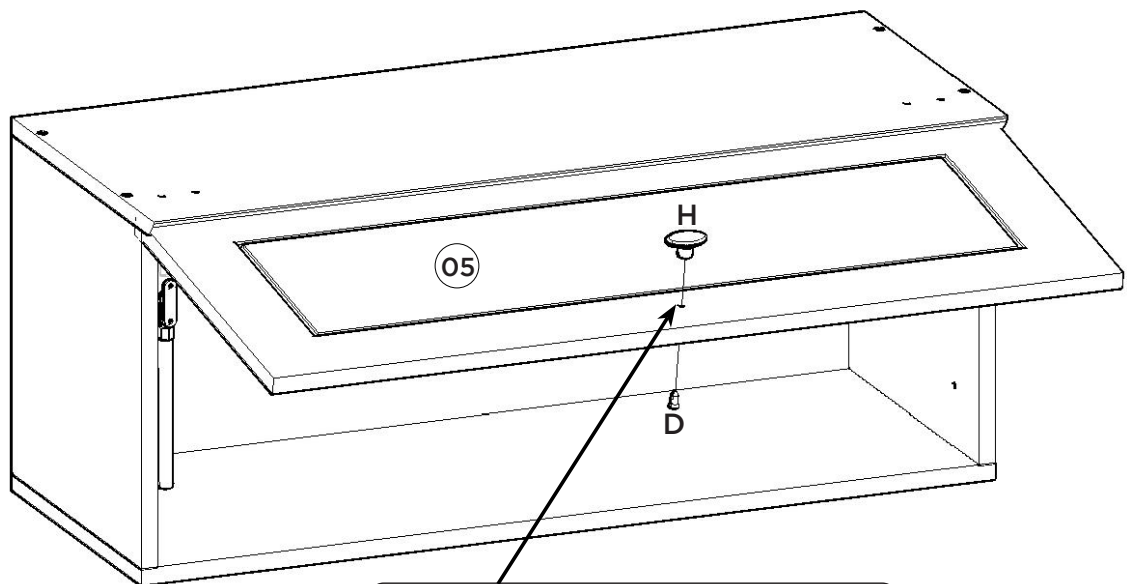

Para colocação do puxador, é necessário fazer a furação passante, com broca de 5mm.

Para colocar el mango, es necesario perforar con un taladro de 5 mm.



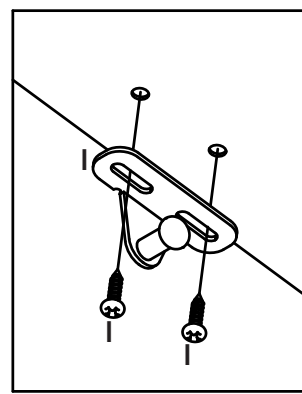
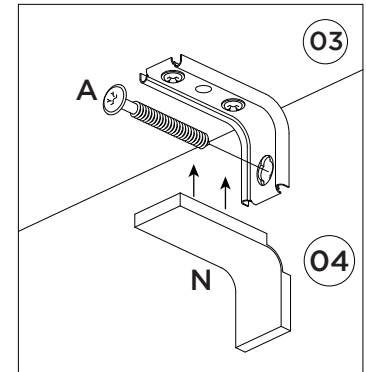
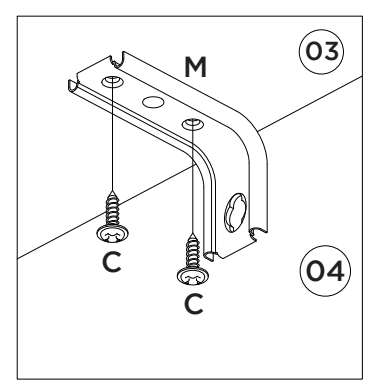
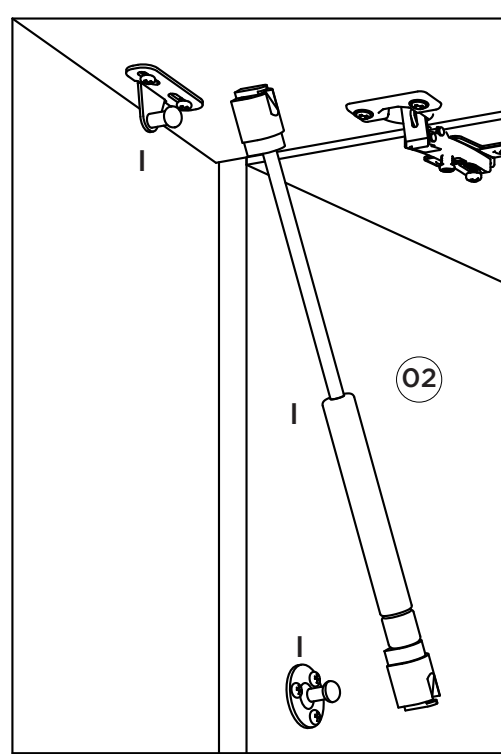
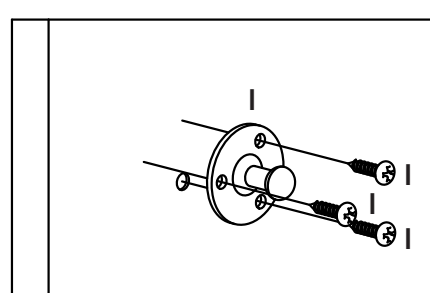
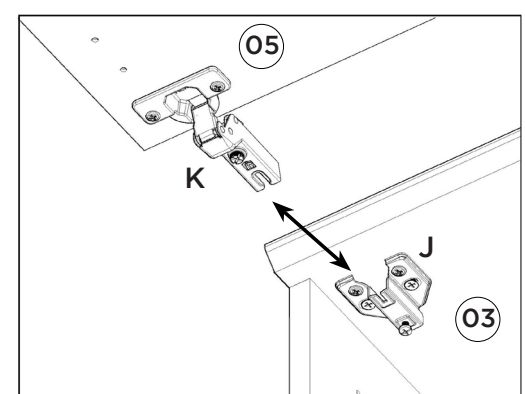
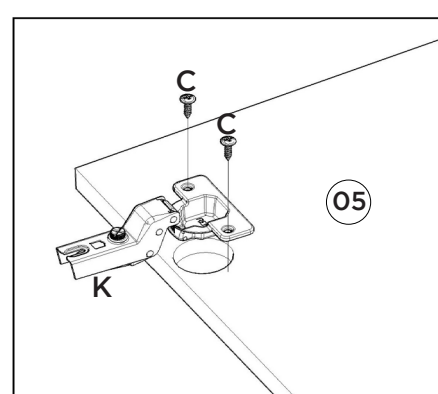
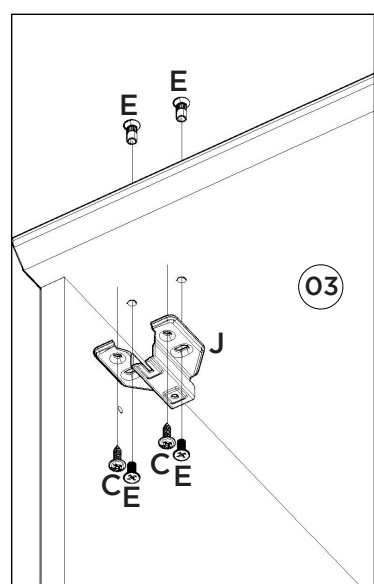





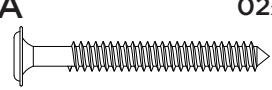

For placing the handle, it is necessary to drill through with a 5mm drill.

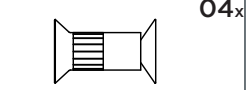
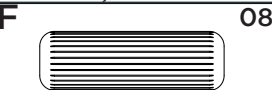
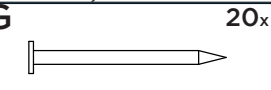

# Lista de Peças | Lista de piezas | List of parts

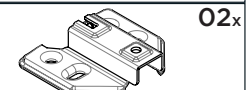
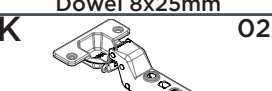
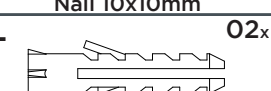
Item	Caixa Caja Box	Qtd Ctd Qty	Descrição   Descripción   Description	Medidas (mm)   Dimensions (mm)   Size (measurements) (mm)
01	1/1	01	Base   Base   Base	800x295x15
02	1/1	02	Lateral Direita Esquerda   Lateral Derecha Izquierda   Right Side Left	307x295x15
03	1/1	01	Tampo   Tapa   Top	800x322x15
04	1/1	01	Fundo   Fondo   Bottom	793x331x3
05	1/1	01	Porta Basculante   Puerta Basculante   Basculating Door	796x315x15

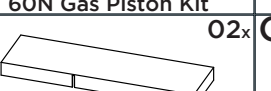
## Ferragens | Herrajes | Hardware

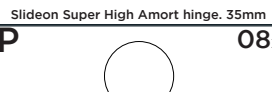
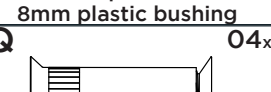
<b>A</b>  Parafuso 5,0x50mm FLA. Tornillo 5,0x50mm FLA. Screw 5,0x50mm FLA.	02x	<b>B</b>  Parafuso 3,5x40mm CHT. Tornillo 3,5x40mm CHT. Screw 3,5x40mm CHT.	08x	<b>C</b>  Parafuso 3,5x14mm FLA. Tornillo 3,5x14mm FLA. Screw 3,5x14mm FLA.	12x	<b>D</b>  Parafuso M4x20mm CHT. ZB Tornillo M4x20mm CHT. ZB Screw M4x20mm CHT. ZB	01x	<b>E</b>  Parafuso União 15mm Tornillo Unión 15mm Union Screw 15mm	04x
<b>F</b>  Cavilha 8x25mm Cinta 8x25mm Dowel 8x25mm	08x	<b>G</b>  Prego 10x10mm Clavo 10x10mm Nail 10x10mm	20x	<b>H</b>  Puxador Pontual PZ14 Oval Tirador Puntual PZ14 Oval PZ14 Oval Point Knob	01x	<b>I</b>  Kit Pistão a Gás 60N Kit Pistón a Gas 60N 60N Gas Piston Kit	01x	<b>J</b>  Calço Removível Calzado extraíble Removable Shim	02x
<b>K</b>  Dobradiça SlideOn Super Alta Amort. 35mm Bisagra Super high amort de Slideon. 35mm Slideon Super High Amort hinge. 35mm	02x	<b>L</b>  Bucha plástica 8mm Bucha de plástico 8mm 8mm plastic bushing	02x	<b>M</b>  Suporte de fixação Soporte de fijación Mounting bracket	02x	<b>N</b>  Proteção para cantoneira Ángulo de protección Protection angle	02x	<b>O</b>  Sachê de cola Bolsa de pegamento Glue bag	01x
<b>P</b>  Adesivo tapa parafuso 10mm Adhesivo tapón de tornillo 10mm Bolt cover adhesive 10mm	08x	<b>Q</b>  Parafuso União 30mm Tornillo Unión 30mm Union Screw 30mm	04x						

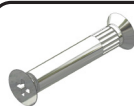

O parafuso (Q) deve ser usada somente quando este módulo for acoplado a outro módulo componível Henn.



El tornillo (Q) se debe utilizar sólo cuando el módulo está conectado a otro módulo componible Henn.



The screw (Q) should be used only when this module is attached to another Henn modular module.

### RECOMENDAÇÃO

Para fixar o móvel na parede usar o suporte de fixação (M), o parafuso 3,5x14mm FLA (C), a Bucha 8mm (L) e o parafuso 5,0x50mm FLA (A).

### RECOMENDACIÓN

Para conectar el móvil a la pared con el soporte (M), tornillo 3,5 x14mm FLA (C), el casquillo de 8 mm (L) y el 5,0 x50mm tornillo FLA (A).

### RECOMMENDATION

To fix the furniture to the wall use the fixing bracket (M), the 3.5x14mm FLA (C) screw, the 8mm bushing (L) and the 5.0x50mm FLA (A).

# INSTRUÇÕES DE MONTAGEM

## INSTRUCCIONES DE MONTAJE ASSEMBLY INSTRUCTIONS

### Requisitos para montagem Requisitor para la montaje Assembly Requirements

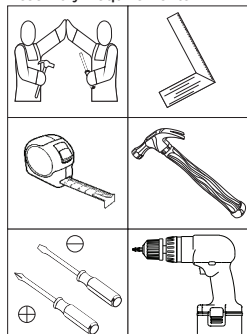

Imagens meramente ilustrativas  
Imágenes meramente ilustrativas  
Images for illustration only



#### OPCIONAL:

**O944-121 Kit Pé Cônico 145mm** (vendido separadamente). Caso opte em colocar pé no produto, utilizar as pré-furações que possui na Base e fixá-lo com o Parafuso que consta no Kit.

#### OPCIONAL:

**O944-121 Kit Pie Cónico 145mm** (se vende por separado). Si opta por colocar pie en el producto, utilizar las pre-huracuras que tenga en la Base y fijarlo con el Tornillo que consta en el Kit.

#### OPTIONAL:

**O944-121 Tapered Foot Kit 145mm** (sold separately). If you choose to put foot in the product, use the pre-drillings in the Base and fix it with the Screw included in the Kit.

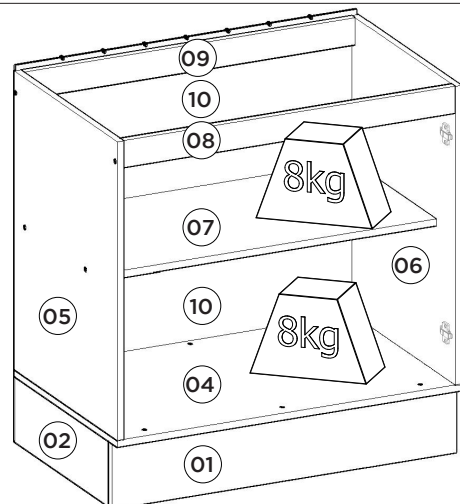
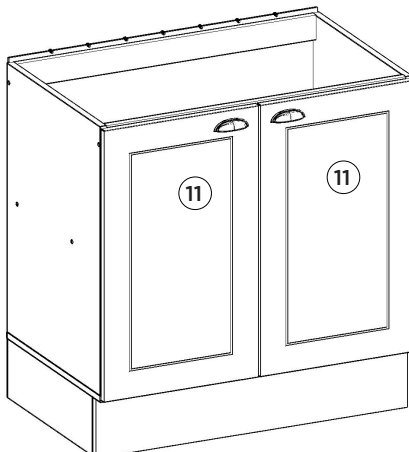

**Pesos máximos recomendados com carga distribuída**  
**Peso máximo recomendado con la carga distribuída**  
**Recommended maximum weights with evenly distributed**

### Lista de Peças | Lista de piezas | List of parts

Item	Caixa Caja Box	Qtd Ctd Qty	Descrição   Descripción   Description	Medidas (mm)   Dimensiones (mm)   Size (measurements) (mm)
01	1/1	01	Rodapé Frontal   Frente pie de página   Front Footer	800x145x15
02	1/1	02	Rodapé Lateral   Pie de página Side   Side Footer	450x145x15
03	1/1	01	Rodapé Traseiro   Pie de página trasera   Rear Footer	768x145x15
04	1/1	01	Base   Base   Base	800x490x15
05	1/1	01	Lateral esquerda   Lateral izquierda   Left side	660x490x15
06	1/1	01	Lateral direita   Lateral derecha   Right side	660x490x15
07	1/1	01	Prateleira   Estante   Shelf	769x400x15
08	1/1	01	Travessa frontal   Travesaño frontal   Front crossbar	769x60x15
09	1/1	01	Travessa traseira   Travesaño trasero   Rear bumper	769x60x15
10	1/1	02	Fundo   Fondo   Bottom	792x341x3
11	1/1	02	Porta   Puerta   Door	665x396x15

#### AVISO

Para limpeza de seu móvel, use uma franela seca ou umedecida, e não utilize produtos químicos que possam danificar seu produto.

#### SISTEMA DE MONTAGEM

O sistema de montagem dos produtos, funciona de acordo com a ordem crescente dos números indicados no desenho. Ex: 01, 02, 03, 04... até a conclusão da montagem.

#### ADVERTENCIA

Para limpieza de su móvil, use una franela seca o húmeda, y no utilice productos químicos que puedan dañar su producto.

#### SISTEMA DE MONTAJE

El sistema de montaje de los productos funciona de acuerdo con el orden creciente de los números indicados en el dibujo. Ej.: 01, 02, 03, 04... hasta la conclusión del montaje.

#### NOTICE

To clean your furniture, use a dry or wet cloth, and do not use chemicals that may damage your product.

#### ASSEMBLY SYSTEM

The products' assembly system works according to the increasing order of the indicated numbers. For example: 01, 02, 03, 04 ... to the end of the assembly.

### Ferragens | Herrajes | Hardware

<b>A</b> 04x  Parafuso 5,0x50mm FLA. Tornillo 5,0x50mm FLA. Screw 5,0x50mm FLA.	<b>B</b> 03x  Parafuso 4,5x50mm CHT. Tornillo 4,5x50mm CHT. Screw 4,5x50mm CHT.	<b>C</b> 18x  Parafuso 3,5x40mm CHT. Tornillo 3,5x40mm CHT. Screw 3,5x40mm CHT.	<b>D</b> 44x  Parafuso 3,5x14mm FLA. Tornillo 3,5x14mm FLA. Screw 3,5x14mm FLA.	<b>E</b> 07x  Parafuso 3,5x12mm CHT. Tornillo 3,5x12mm CHT. Screw 3,5x12mm CHT.	<b>F</b> 04x  Parafuso M4x20mm CHT. ZB Tornillo M4x20mm CHT. ZB Screw M4x20mm CHT. ZB	<b>G</b> 04x  Parafuso União 30mm Tornillo Unión 30mm Union Screw 30mm	<b>H</b> 24x  Cavilha 8x25mm Cinta 8x25mm Dowel 8x25mm
<b>I</b> 27x  Prego 10x10mm Clavo 10x10mm Nail 10x10mm	<b>J</b> 07x  Fixador de fundos Fijador de fondos Bottom fixer	<b>K</b> 08x  Cantoneira plástica Cantонера plástica Plastic angle brackets	<b>L</b> 02x  Puxador Concha Tirador Concha Shell Handle	<b>M</b> 04x  Calço Removível Calzado extraíble Removable Shim	<b>N</b> 04x  Dobradica SlideOn Baixo Amortecedor 35mm Biagra SlideOn Baja Amortiguador 35mm Low SlideOn Hinge 35mm Shock Absorber	<b>O</b> 04x  Buchta plástica 8mm Buchta de plástico 8mm 8mm plastic bushing	<b>P</b> 02x  Suporte de fixação Soporte de fijación Mounting bracket
<b>Q</b> 02x  Proteção para cantoneira Ángulo de protección Protection angle	<b>R</b> 02x  Giz de correção Tiza de corrección Chalk of correction	<b>S</b> 01x  Sachê de cola Bolsa de pegamento Glue bag	<b>T</b> 22x  Adesivo tapa parafuso 10mm Adhesivo tapón de tornillo 10mm Bolt cover adhesive 10mm	<b>U</b> 04x  Prego 12x12mm Anelado Clavo 12x12mm Anillado Ringed Nails 12x12mm	<b>V</b> 04x  Sapata "L" 16x20mm Zapata "L" 16x20mm "L" shoe 16x20mm		

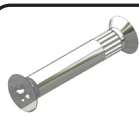

O parafuso (G) deve ser usada somente quando este módulo for acoplado a outro módulo componível Henn.



El tornillo (G) se debe utilizar sólo cuando el módulo está conectado a otro módulo componible Henn.



The screw (G) should be used only when this module is attached to another Henn modular module.

### RECOMENDAÇÃO

Para fixar o móvel na parede usar o suporte de fixação (P), o parafuso 3,5x14mm FLA (D), a Bucha 8mm (O) e o parafuso 5,0x50mm FLA (A).

### RECOMENDACIÓN

Para conectar el móvil a la pared con el soporte (P), tornillo 3,5 x14mm FLA (D), el casquillo de 8 mm (O) y el 5,0 x50mm tornillo FLA (A).

### RECOMMENDATION

To fix the furniture to the wall use the mounting bracket (P), the 3.5x14mm FLA (D) screw, the 8mm bushing (O) and the 5.0x50mm FLA screw (A).

1º

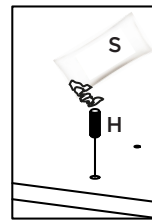
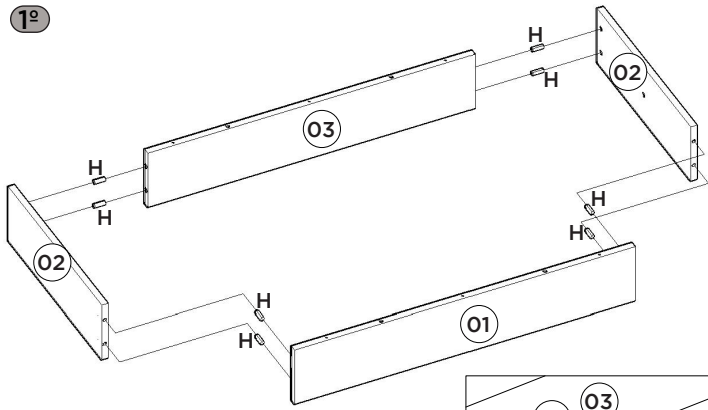

Utilizar o sachê de cola (S) em todas as cavilhas (H) do produto.

Con el pegamento sobre (S) en todos los pernos (H) producto.

Use the glue sachet (S) on all the pegs (H) of the product.

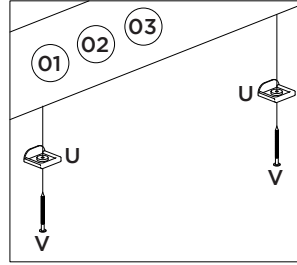
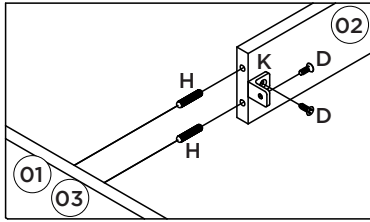

2º

Esse tampo é opcional e é vendido separadamente (C904-114).

Esta vez es opcional y se vende por separado (C904-114).

This top is optional and is sold separately (C904-114).

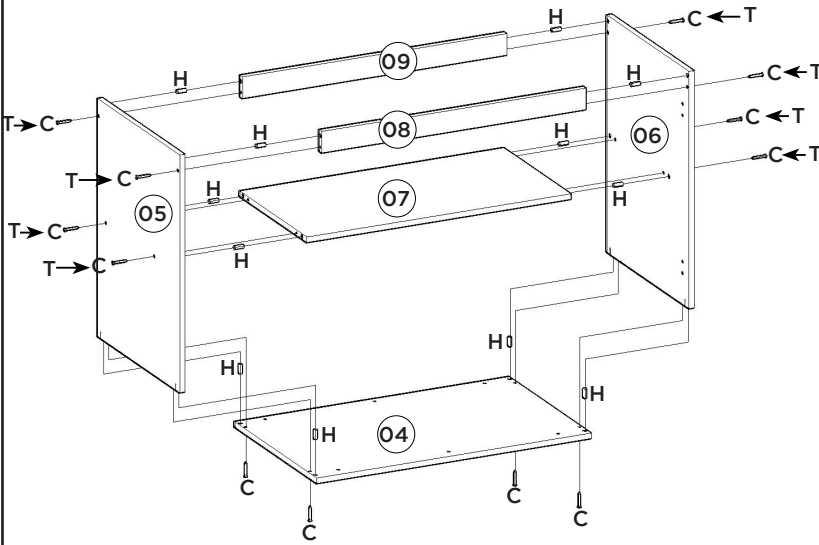
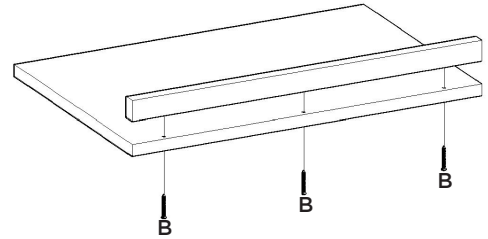

4º

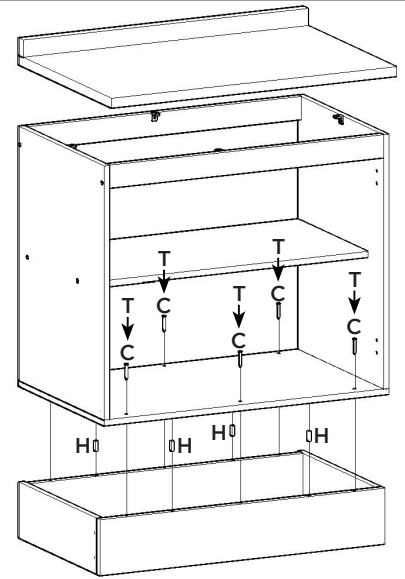
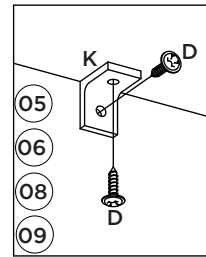

5º

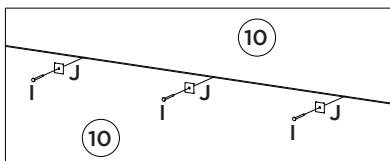
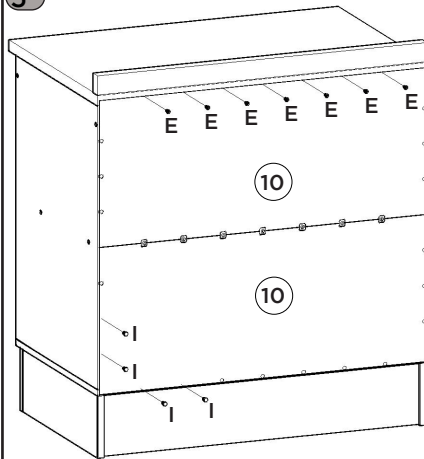

6º

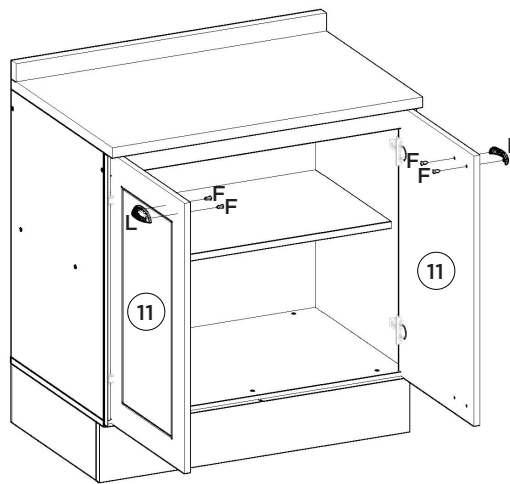

Para colocação dos puxadores, é necessário fazer a furação passante, com Broca de 5mm.

Para la colocación de las asas, es necesario perforar a través, con una broca de 5mm.

To place the handles is necessary to make the through hole, drill 5mm.

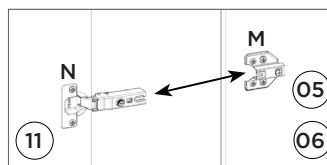
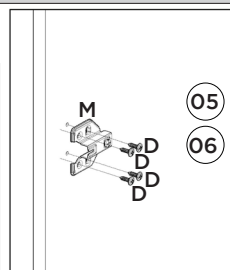
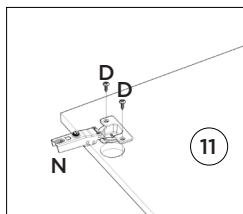
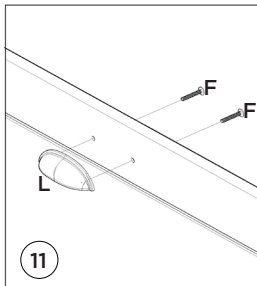

7º

Opção Suspensa

Opción suspendida

Suspended Option

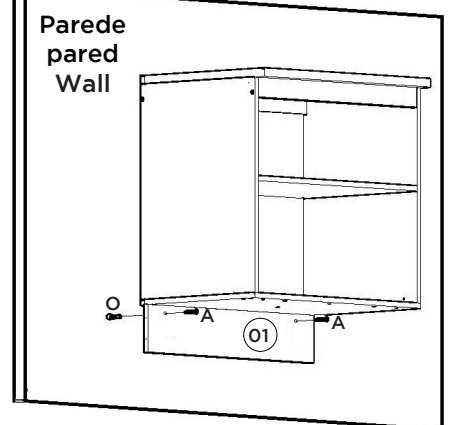
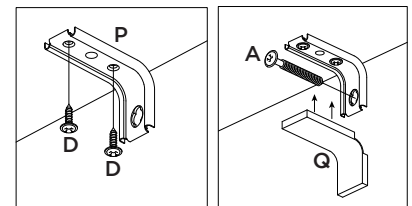



# INSTRUÇÕES DE MONTAGEM

## INSTRUCCIONES DE MONTAJE ASSEMBLY INSTRUCTIONS

Requisitos para montagem  
Requisitor para la montaje  
Assembly Requirements

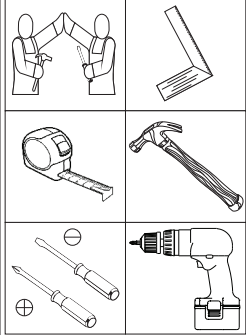

Imagens meramente ilustrativas  
Imágenes meramente ilustrativas  
Images for illustration only

Opção 1  
Opción 1  
Option 1

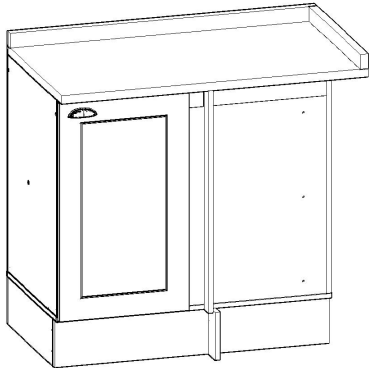

Opção 2  
Opción 2  
Option 2

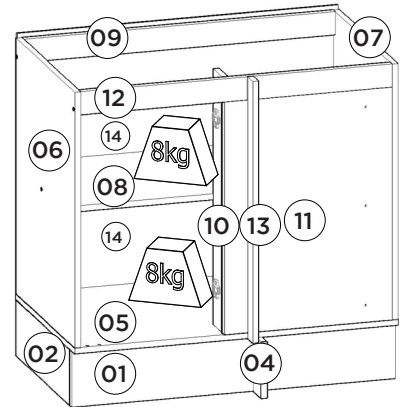
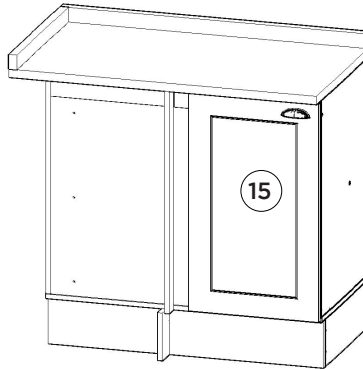

Pesos máximos recomendados com carga distribuída  
Peso máximo recomendado con la carga distribuida  
Recommended maximum weights with evenly distributed.

### Lista de Peças | Lista de piezas | List of parts

Item	Caixa Caja Box	Qtd Ctd Qty	Descrição   Descripción   Description	Medidas (mm)   Dimensions (mm)   Size (measurements) (mm)
01	1/1	01	Rodapé Frontal   Frente pie de página   Front Footer	840x145x15
02	1/1	02	Rodapé Lateral   Pie de página Side   Side Footer	450x145x15
03	1/1	01	Rodapé Traseiro   Pie de página trasera   Rear Footer	808x145x15
04	1/1	01	Rodapé fechamento   Pie de página de cierre   Closing footer	145x68x15
05	1/1	01	Base   Base   Base	840x490x15
06	1/1	01	Lateral esquerda   Lateral izquierda   Left side	660x490x15
07	1/1	01	Lateral direita   Lateral derecha   Right side	660x490x15
08	1/1	01	Prateleira   Estante   Shelf	808x400x15
09	1/1	01	Travessa traseira   Travesaño trasero   Rear bumper	808x60x15
10	1/1	01	Pilastra da Porta   Puerta pilastra   Door Pilaster	660x75x15
11	1/1	01	Frente Fixa   Frente Fija   Fixed Front	600x435x15
12	1/1	01	Travessa frontal   Travesaño frontal   Front crossbar	808x60x15
13	1/1	01	Travessa Estrutural   Travesa Estructural   Travessa Estructural	675x43x15
14	1/1	02	Fundo   Fondo   Bottom	832x341x3
15	1/1	02	Porta   Puerta   Door	665x396x15

#### AVISO

Para limpeza de seu móvel, use uma flanela seca ou umedecida, e não utilize produtos químicos que possam danificar seu produto.

#### SISTEMA DE MONTAGEM

O sistema de montagem dos produtos, funciona de acordo com a ordem crescente dos números indicados no desenho. Ex: 01, 02, 03, 04... até a conclusão da montagem.

#### ADVERTENCIA

Para limpeza de su móvil, use una flanela seca o húmeda, y no utilice productos químicos que puedan dañar su producto.

#### SISTEMA DE MONTAJE

El sistema de montaje de los productos funciona de acuerdo con el orden creciente de los números indicados en el dibujo. Ej.: 01, 02, 03, 04... hasta la conclusión del montaje.

#### NOTICE

To clean your furniture, use a dry or wet cloth, and do not use chemicals that may damage your product.

#### ASSEMBLY SYSTEM

The products' assembly system works according to the increasing order of the indicated numbers. For example: 01, 02, 03, 04 ... to the end of the assembly.

### Ferragens | Herrajes | Hardware

<b>A</b> 05x Parafuso 5,0x50mm FLA. Tornillo 5,0x50mm FLA. Screw 5,0x50mm FLA.	<b>B</b> 05x Parafuso 4,5x50mm CHT. Tornillo 4,5x50mm CHT. Screw 4,5x50mm CHT.	<b>C</b> 19x Parafuso 3,5x40mm CHT. Tornillo 3,5x40mm CHT. Screw 3,5x40mm CHT.	<b>D</b> 02x Parafuso M4x20mm CHT. ZB Tornillo M4x20mm CHT. ZB Screw M4x20mm CHT. ZB	<b>E</b> 52x Parafuso 3,5x14mm FLA. Tornillo 3,5x14mm FLA. Screw 3,5x14mm FLA.	<b>F</b> 07x Parafuso 3,5x12mm CHT. Tornillo 3,5x12mm CHT. Screw 3,5x12mm CHT.	<b>G</b> 03x Parafuso 4,0x25mm CHT. Tornillo 4,0x25mm CHT. Screw 4,0x25mm CHT.	<b>H</b> 04x Parafuso União 30mm Tornillo Unión 30mm Union Screw 30mm
<b>I</b> 04x Prego 12x12mm Anelado Clavo 12x12mm Anillado Ringed Nails 12x12mm	<b>J</b> 26x Prego 10x10mm Clavo 10x10mm Nail 10x10mm	<b>K</b> 07x Fixador de fundos Fijador de fondos Bottom fixer	<b>L</b> 29x Cavilha 8x25mm Cinta 8x25mm Dowel 8x25mm	<b>M</b> 04x Sapata "L" 16x20mm Zapata "L" 16x20mm "L" shoe 16x20mm	<b>N</b> 02x Suporte metal Soporte metálico Metal support	<b>O</b> 15x Cantoneira plástica Cantonera plástica Plastic angle brackets	<b>P</b> 01x Puxador Concha Tirador Concha Shell Handle
<b>Q</b> 02x Calço Removível Calzado extraíble Removable Shim	<b>R</b> 02x Dobradica SlideOn Baixa Amortecedor 35mm Bisagra SlideOn Baja Amortiguador 35mm Low SlideOn Hinge 35mm Shock Absorber	<b>S</b> 05x Bucha plástica 8mm Bucha de plástico 8mm 8mm plastic bushing	<b>T</b> 03x Suporte de fixação Soporte de fijación Mounting bracket	<b>U</b> 03x Proteção para cantoneira Ángulo de protección Protection angle	<b>V</b> 02x Sachê de cola Bolsa de pegamento Glue bag	<b>W</b> 02x Giz de correção Tiza de corrección Chalk of correction	<b>X</b> 10x Adesivo tapa parafuso 10mm Adhesivo tapón de tornillo 10mm Bolt cover adhesive 10mm

O parafuso (H) deve ser usada somente quando este módulo for acoplado a outro módulo componível Henn.

El tornillo (H) se debe utilizar sólo cuando el módulo está conectado a otro módulo componible Henn.

The screw (H) should be used only when this module is attached to another Henn modular module.

#### RECOMENDAÇÃO

Para fixar o móvel na parede usar o suporte de fixação (T), o parafuso 3,5x14mm FLA (E), a Bucha 8mm (S) e o parafuso 5,0x50mm FLA (A).

#### RECOMENDACIÓN

Para conectar el móvil a la pared con el soporte (T), tornillo 3,5 x14mm FLA (E), el casquillo de 8 mm (S) y el 5,0x50mm tornillo FLA (A).

#### RECOMMENDATION

To fix the furniture to the wall use the mounting bracket (T), the 3.5x14mm FLA (E) screw, the 8mm bushing (S) and the 5.0x50mm FLA screw (A).

#### RECOMENDAÇÃO

Ao unir um outro produto neste, utilizar 2 Cantoneiras (O) e 4 Parafusos 3,5x14mm FLA (E) na peça 04.

1º

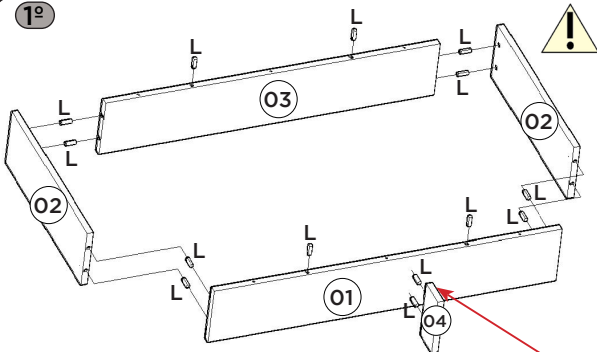

Fazer a furação passante na peça (01) para colocação das cavilhas (L) com a peça (04), conforme opção 1 (lado direito) ou opção 2 (lado esquerdo).

Perfore a través del orificio (01) para insertar los pasadores (L) con la pieza (04), de acuerdo con la opción 1 (lado derecho) o la opción 2 (lado izquierdo).

Drill through the hole (01) to insert the pins (L) with the piece (04), according to option 1 (right side) or option 2 (left side).

Utilizar o sachê de cola (V) em todas as cavilhas (L) do produto.  
Con el pegamento sobre (V) en todos los pernos (L) producto.  
Use the glue sachet (V) on all the pegs (L) of the product.

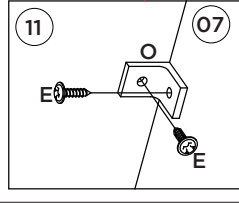
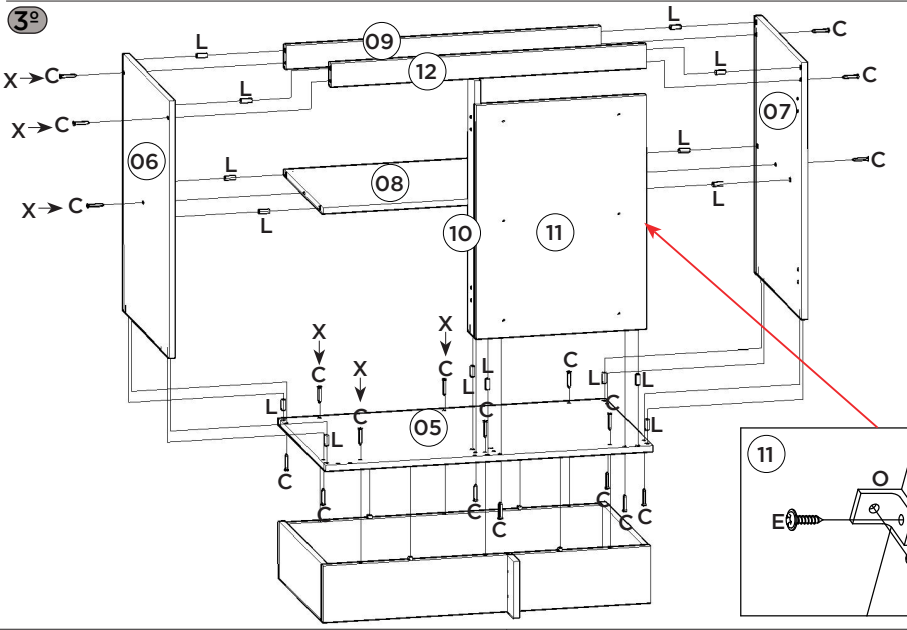
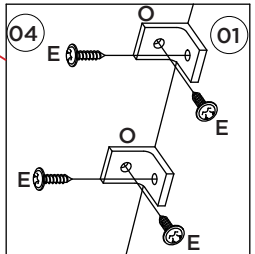
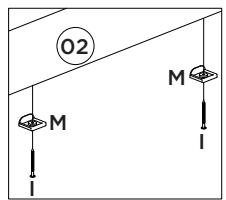
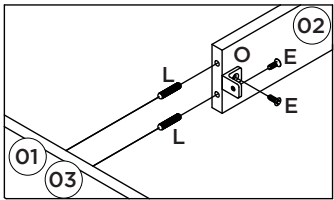
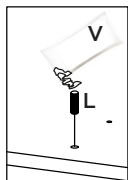

5º

Vista traseira  
Vista trasera  
Back view

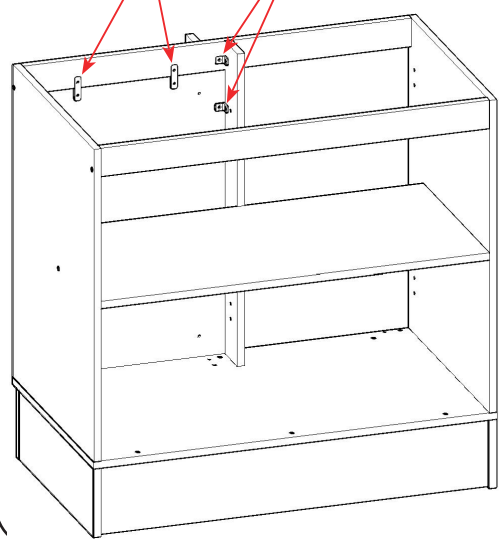
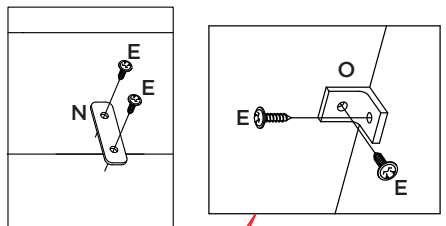

6º

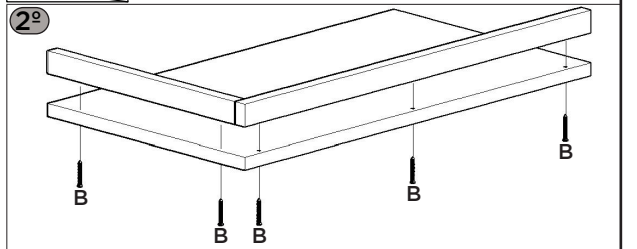
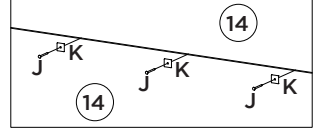
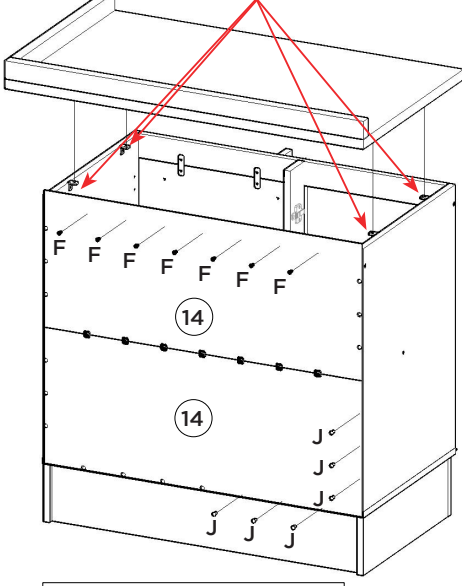
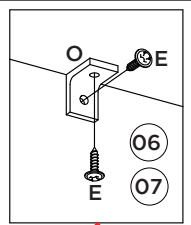

Esse tampo é opcional e é vendido separadamente (C906-114).  
Esta vez es opcional y se vende por separado (C906-114).  
This top is optional and is sold separately (C906-114).

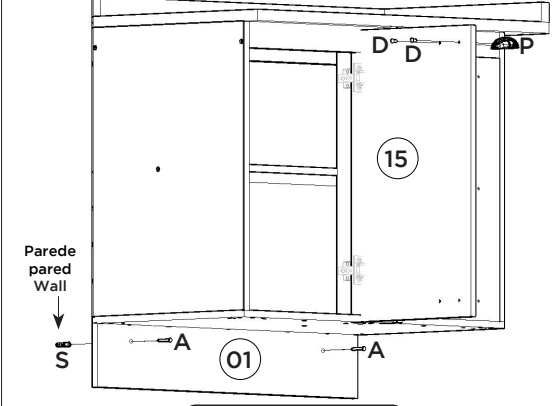
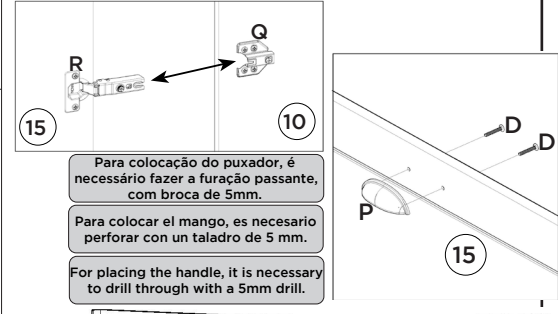
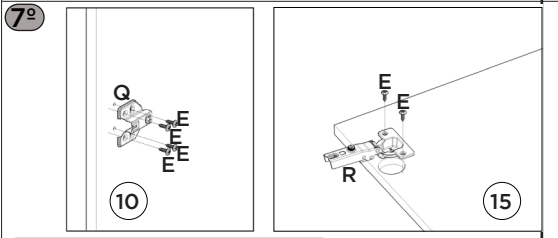
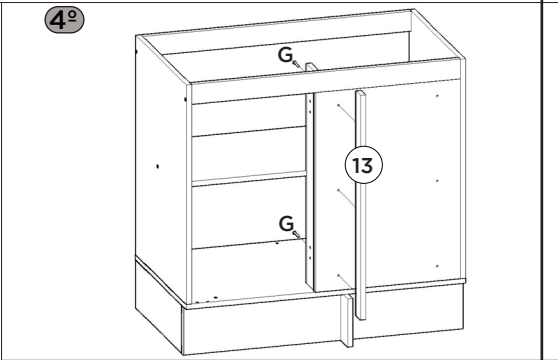

Opção Suspensa  
Opción suspendida  
Suspended Option

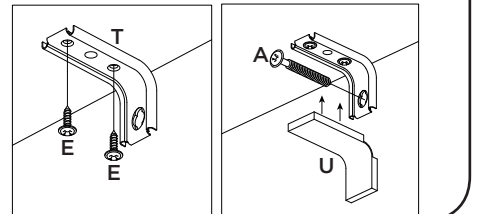

# INSTRUÇÕES DE MONTAGEM

## INSTRUCCIONES DE MONTAJE ASSEMBLY INSTRUCTIONS

### Requisitos para montagem Requisitor para la montaje Assembly Requirements

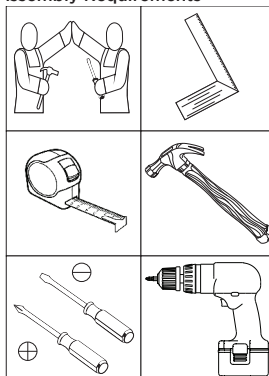

Imagens meramente ilustrativas  
Imágenes meramente ilustrativas  
Images for illustration only

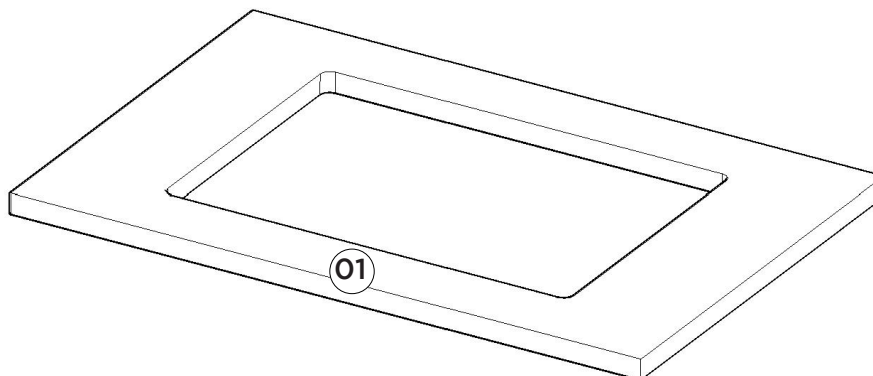

### Lista de Peças | Lista de piezas | List of parts

Item	Caixa Caja Box	Qtd Ctd Qty	Descrição   Descripción   Description	Medidas (mm)   Dimensions (mm)   Size (measure- ments) (mm)
01	1/1	01	Tampo   Tapa   Top	800x533x25

### Ferragens | Herrajes | Hardware

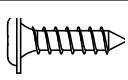
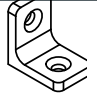
<b>A</b>		08x	<b>B</b>		04x
Parafuso 3,5x14mm FLA. Tornillo 3,5x14mm FLA. Screw 3,5x14mm FLA.			Cantoneira plástica Cantonera plástica Plastic angle brackets		

 Estas ferragens constam no Pacote do respectivo Balcão.  
Estos herrajes constan en el Paquete del respectivo Balcón.  
These hardware are included in the Package of the respective Counter.

### AVISO

Para limpeza de seu móvel, use uma flanela seca ou umedecida, e não utilize produtos químicos que possam danificar seu produto.

### SISTEMA DE MONTAGEM

O sistema de montagem dos produtos, funciona de acordo com a ordem crescente dos números indicados no desenho. Ex: 01, 02, 03, 04... até a conclusão da montagem.

### ADVERTENCIA

Para limpieza de su móvil, use una flanela seca o húmeda, y no utilice productos químicos que puedan dañar su producto.

### SISTEMA DE MONTAJE

El sistema de montaje de los productos funciona de acuerdo con el orden creciente de los números indicados en el dibujo. Ej.: 01, 02, 03, 04... hasta la conclusión del montaje.

### NOTICE

To clean your furniture, use a dry or wet cloth, and do not use chemicals that may damage your product.

### ASSEMBLY SYSTEM

The products' assembly system works according to the increasing order of the indicated numbers. For example: 01, 02, 03, 04 ... to the end of the assembly.

1º

Esse tampo é opcional e é vendido separadamente

Esta vez es opcional y se vende por separado

This top is optional and is sold separately

Exemplo de como fixar o Tampo Cooktop no produto.

Ejemplo de cómo fijar el Tablero Cooktop en el producto.

Example of how to secure the Cooktop Top to the product.

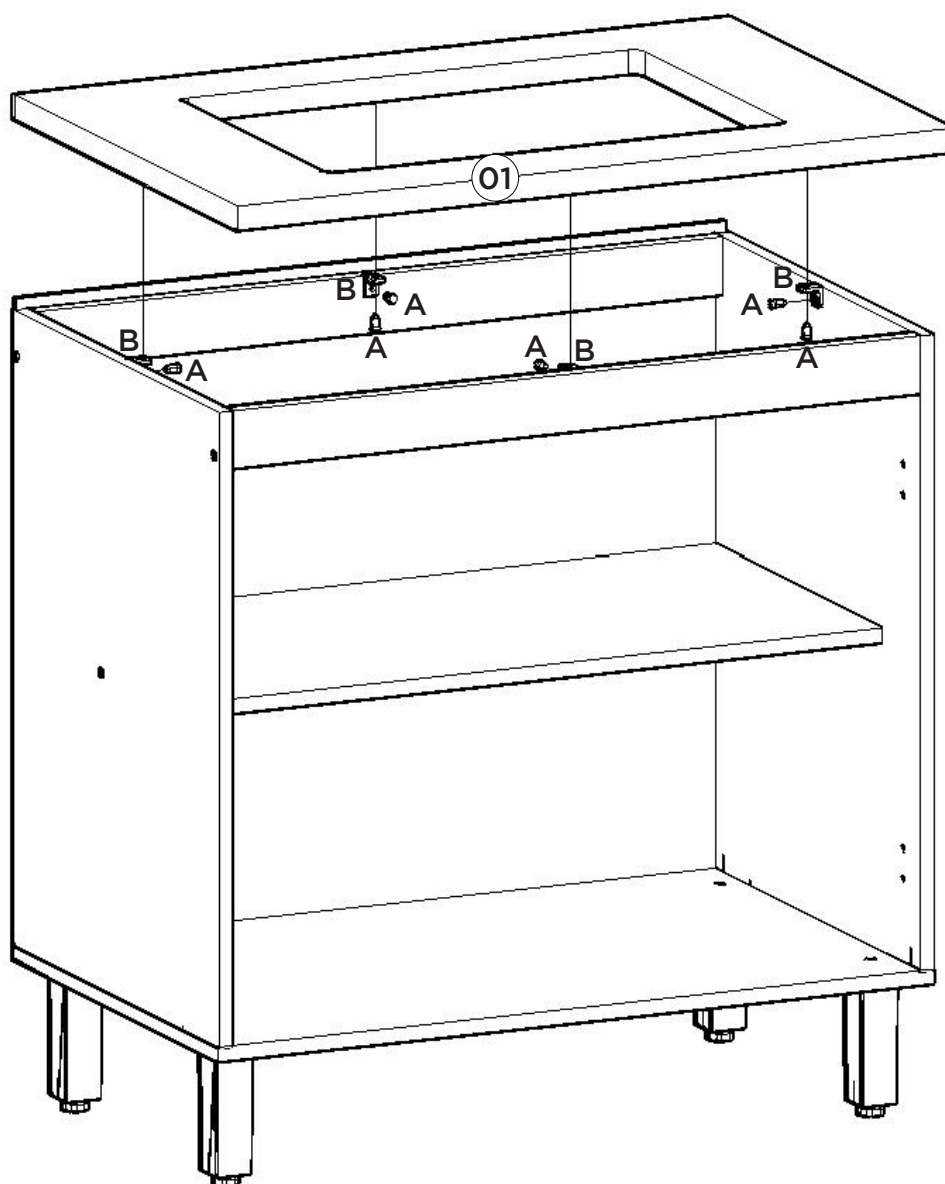

# INSTRUÇÕES DE MONTAGEM

## INSTRUCCIONES DE MONTAJE ASSEMBLY INSTRUCTIONS

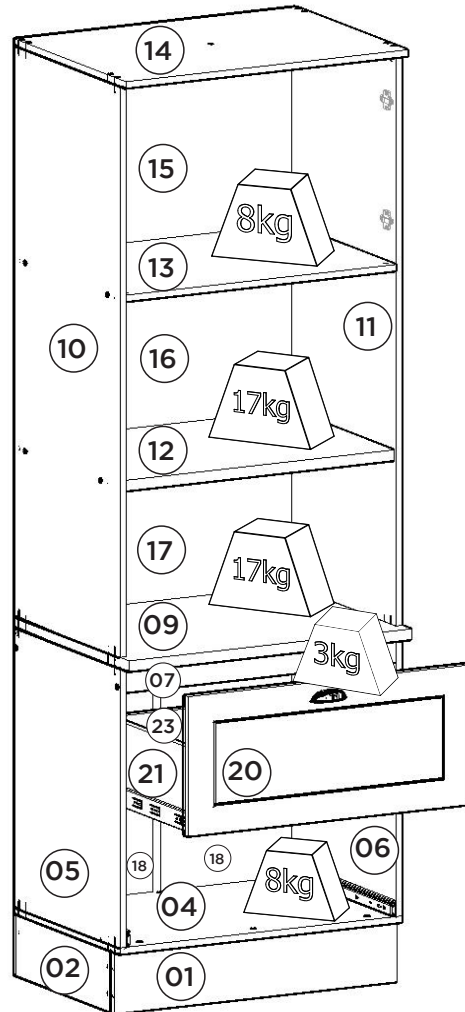
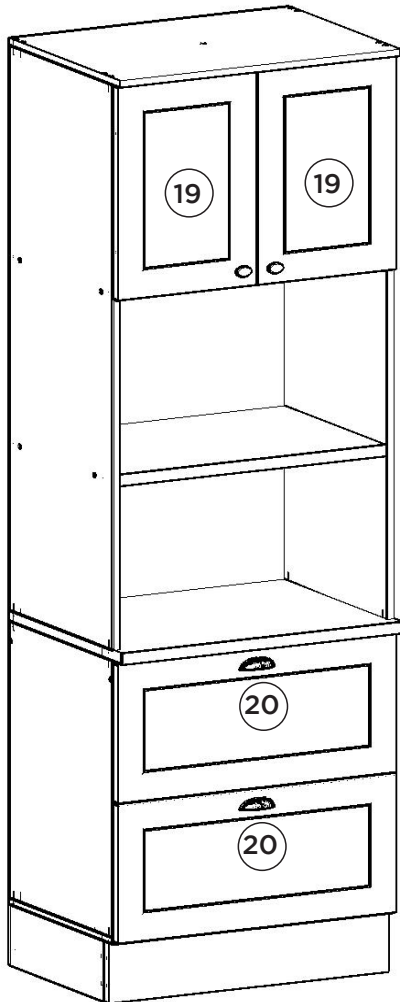

Pesos máximos recomendados com carga distribuída  
Peso máximo recomendado con la carga distribuida  
Recommended maximum weights with evenly distributed.

### Requisitos para montagem Requisitor para la montaje Assembly Requirements

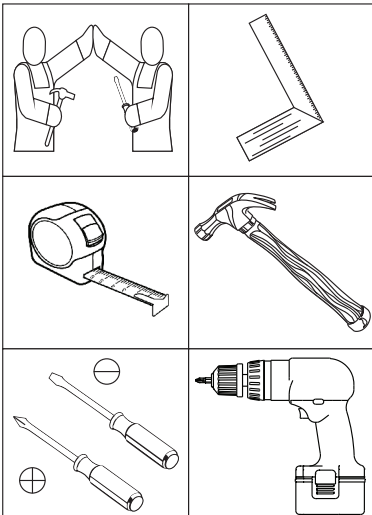

Imagens meramente ilustrativas  
Imágenes meramente ilustrativas  
Images for illustration only

### AVISO

Para limpeza de seu móvel, use uma flanela seca ou umedecida, e não utilize produtos químicos que possam danificar seu produto.

### SISTEMA DE MONTAGEM

O sistema de montagem dos produtos, funciona de acordo com a ordem crescente dos números indicados no desenho. Ex: 01, 02, 03, 04... até a conclusão da montagem.

### ADVERTENCIA

Para limpieza de su móvil, use una flanela seca o húmeda, y no utilice productos químicos que puedan dañar su producto.

### SISTEMA DE MONTAJE

El sistema de montaje de los productos funciona de acuerdo con el orden creciente de los números indicados en el dibujo. Ej.: 01, 02, 03, 04... hasta la conclusión del montaje.

### NOTICE

To clean your furniture, use a dry or wet cloth, and do not use chemicals that may damage your product.

### ASSEMBLY SYSTEM

The products' assembly system works according to the increasing order of the indicated numbers. For example: 01, 02, 03, 04 ... to the end of the assembly.

1º

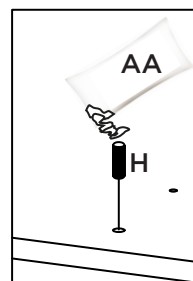
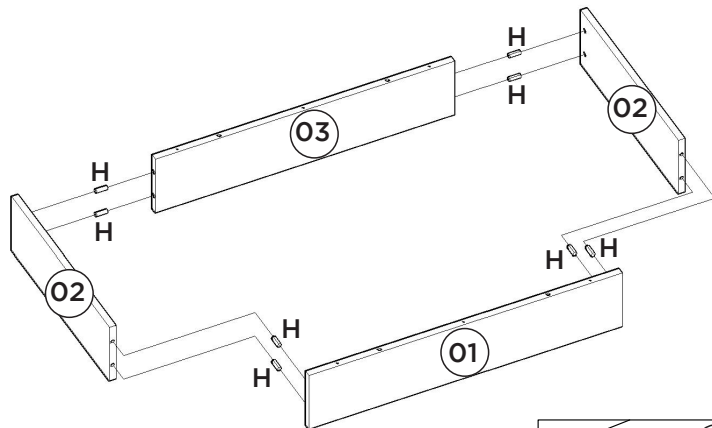

Utilizar o sachê de cola (AA) em todas as cavilhas (H) do produto.

Con el pegamento sobre (AA) en todos los pernos (H) producto.

Use the glue sachet (AA) on all the pegs (H) of the product.

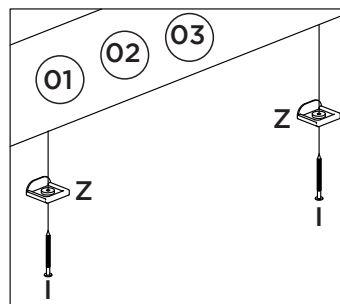
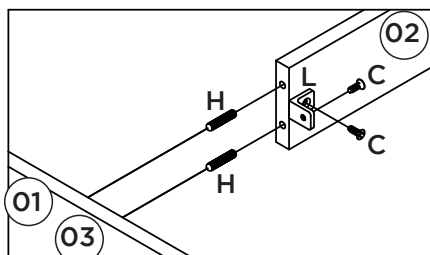

2º

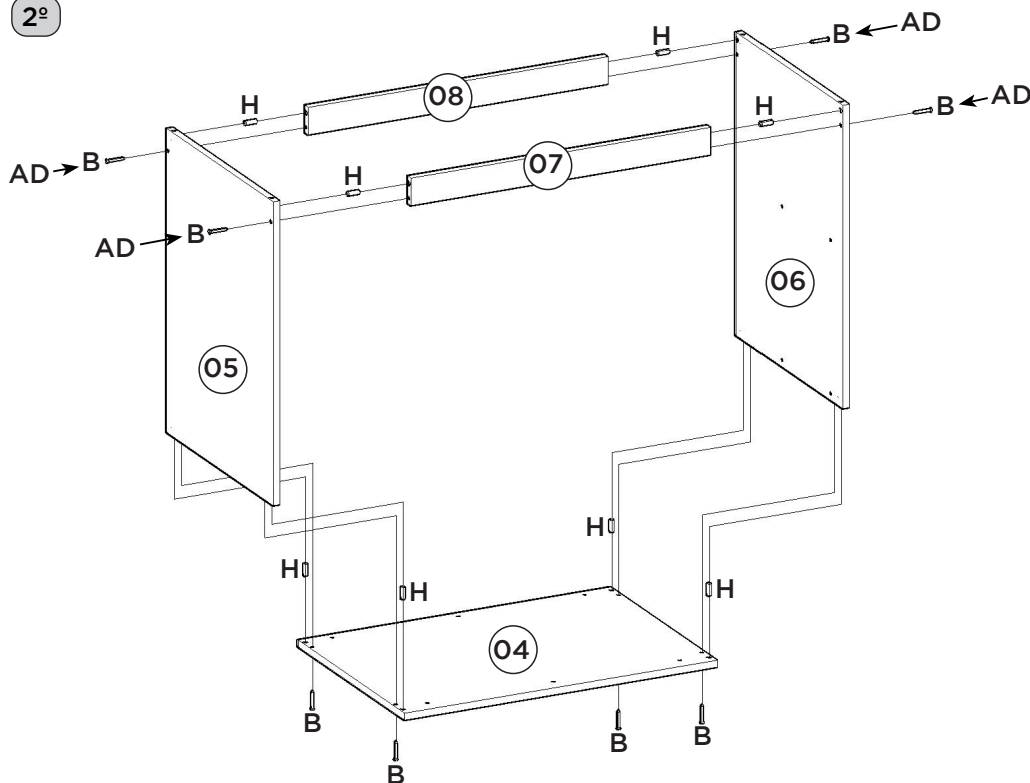
**OPCIONAL:**

O944-121 Kit Pé Cônico 145mm (vendido separadamente). Caso opte em colocar pé no produto, utilizar as pré-furações que possui na Base e fixá-lo com o Parafuso que consta no Kit.

**OPCIONAL:**

O944-121 Kit Pie Cónico 145mm (se vende por separado). Si opta por colocar pie en el producto, utilizar las pre-huracuras que tenga en la Base y fijarlo con el Tornillo que consta en el Kit.

**OPTIONAL:**

O944-121 Tapered Foot Kit 145mm (sold separately). If you choose to put foot in the product, use the pre-drillings in the Base and fix it with the Screw included in the Kit.

3º

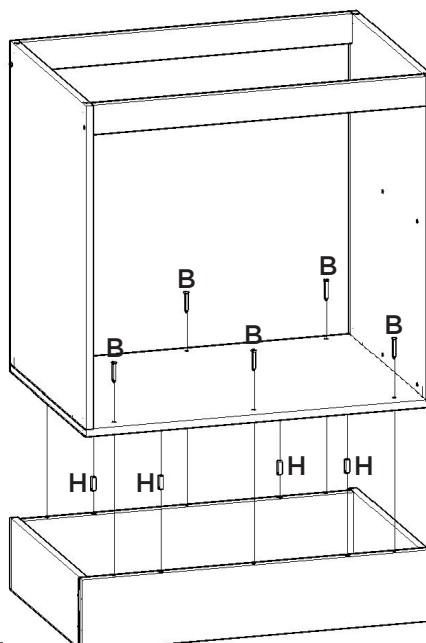

4°

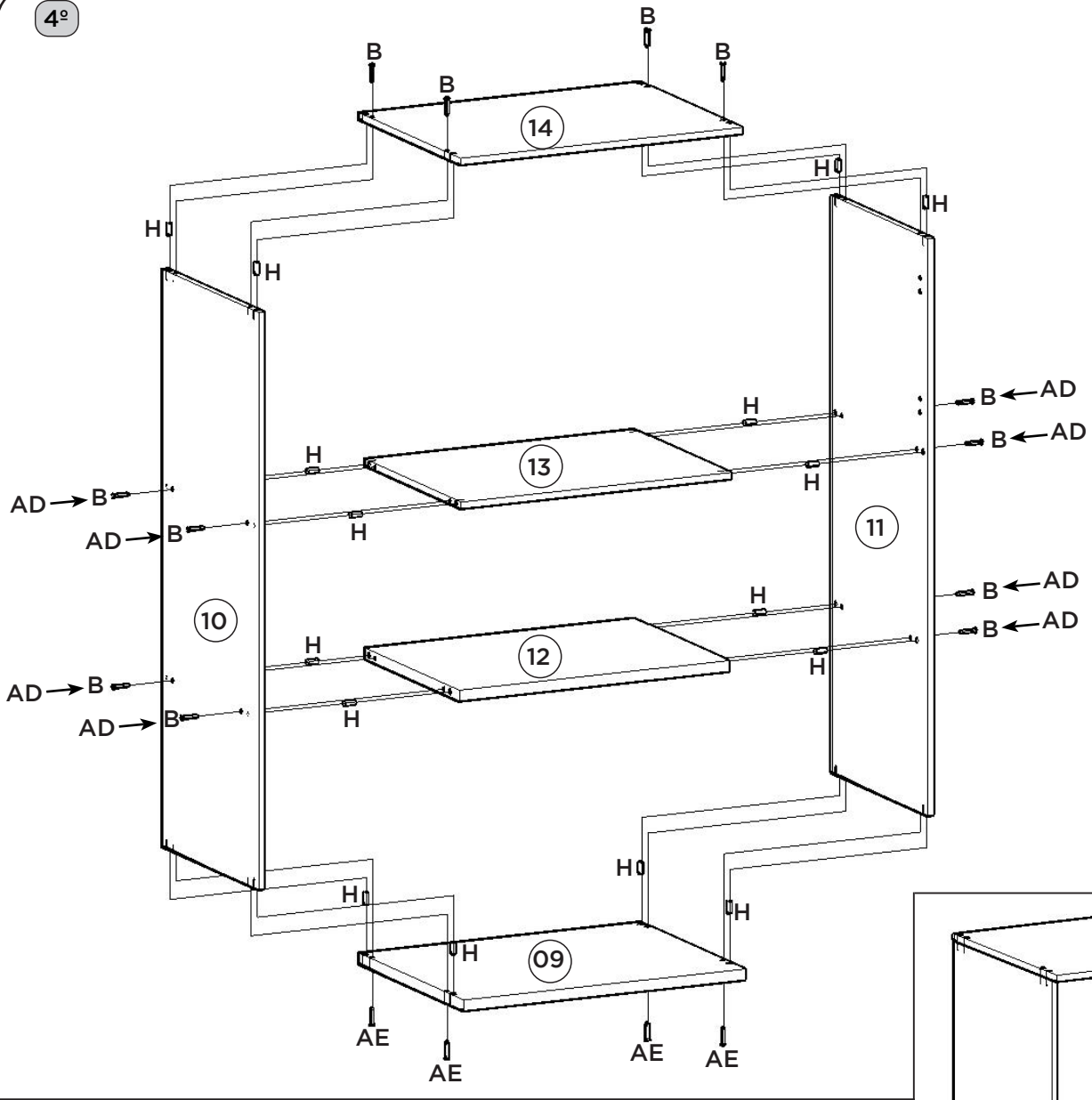

5°

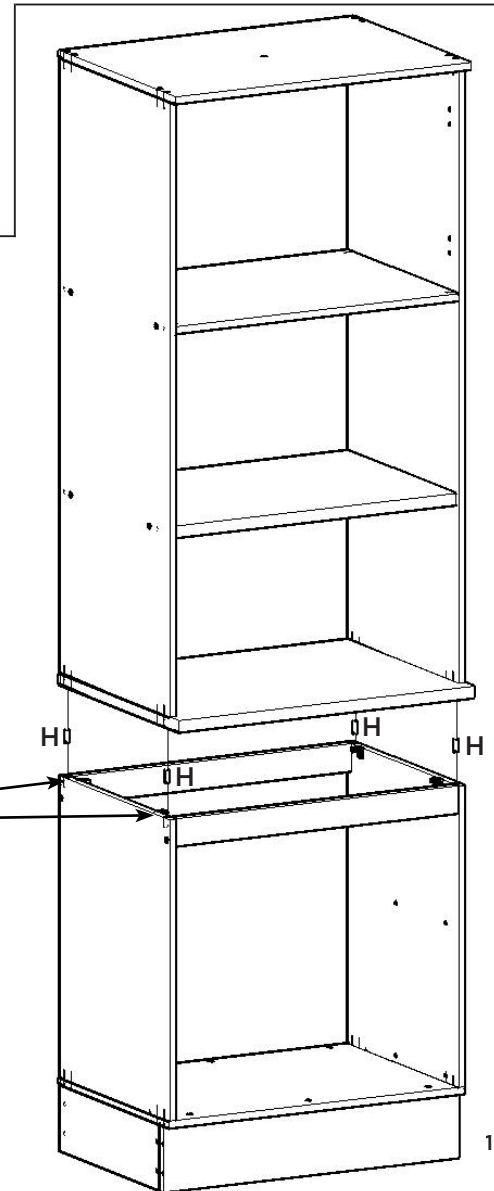
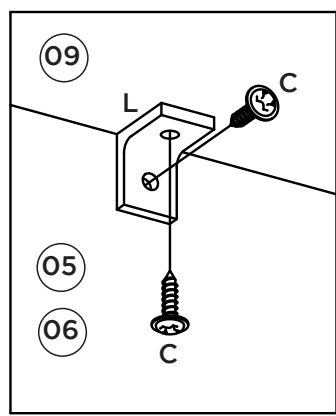

**ATENÇÃO:** Por questão de segurança, recomendamos a não utilização dos Fundos (16 e 17) caso o espaço seja utilizado por forno elétrico ou forno embutido, dessa forma, haverá melhor propagação do calor, evitando danos em seu móvel.

**ATENCIÓN:** Por razones de seguridad, recomendamos la no utilización de los Fondos (16 y 17) en caso de que el espacio sea utilizado por horno eléctrico o horno embutido, de esa forma, habrá mejor propagación del calor, evitando daños en su mueble.

**WARNING:** For safety reasons, we recommend that you do not use the bottoms (16 and 17) if the space is used by an electric oven or built-in oven, in this way, there will be better propagation of the heat, avoiding damage to your furniture.

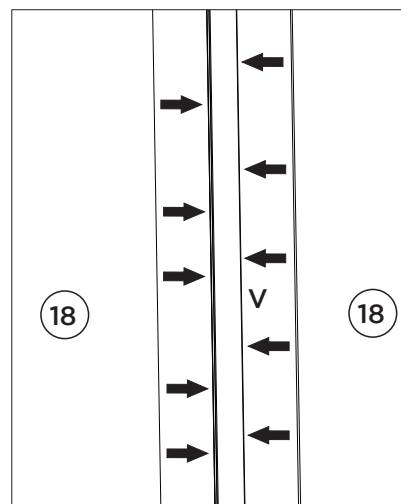
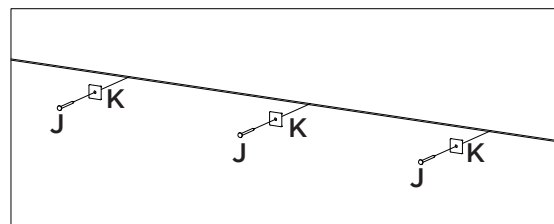
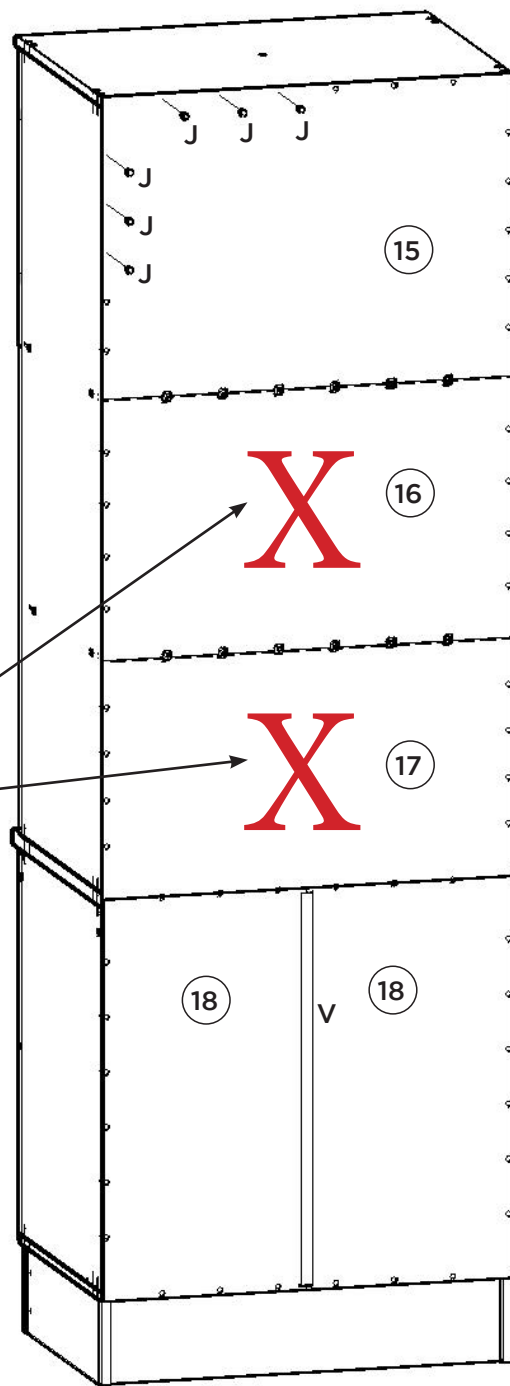



Opção Suspensa

Opción suspendida

Suspended Option

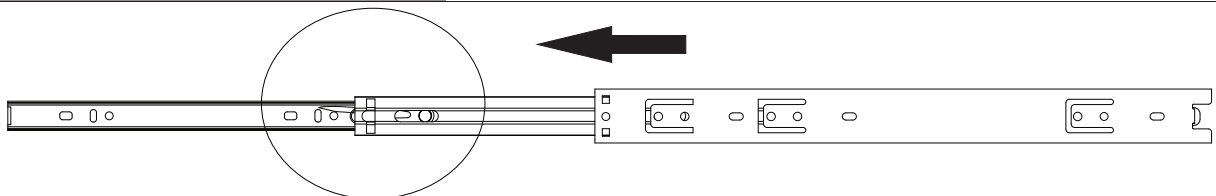
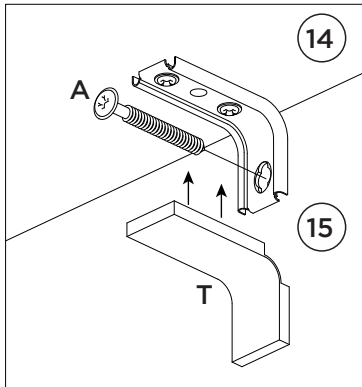
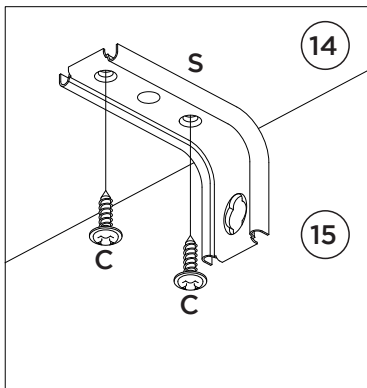
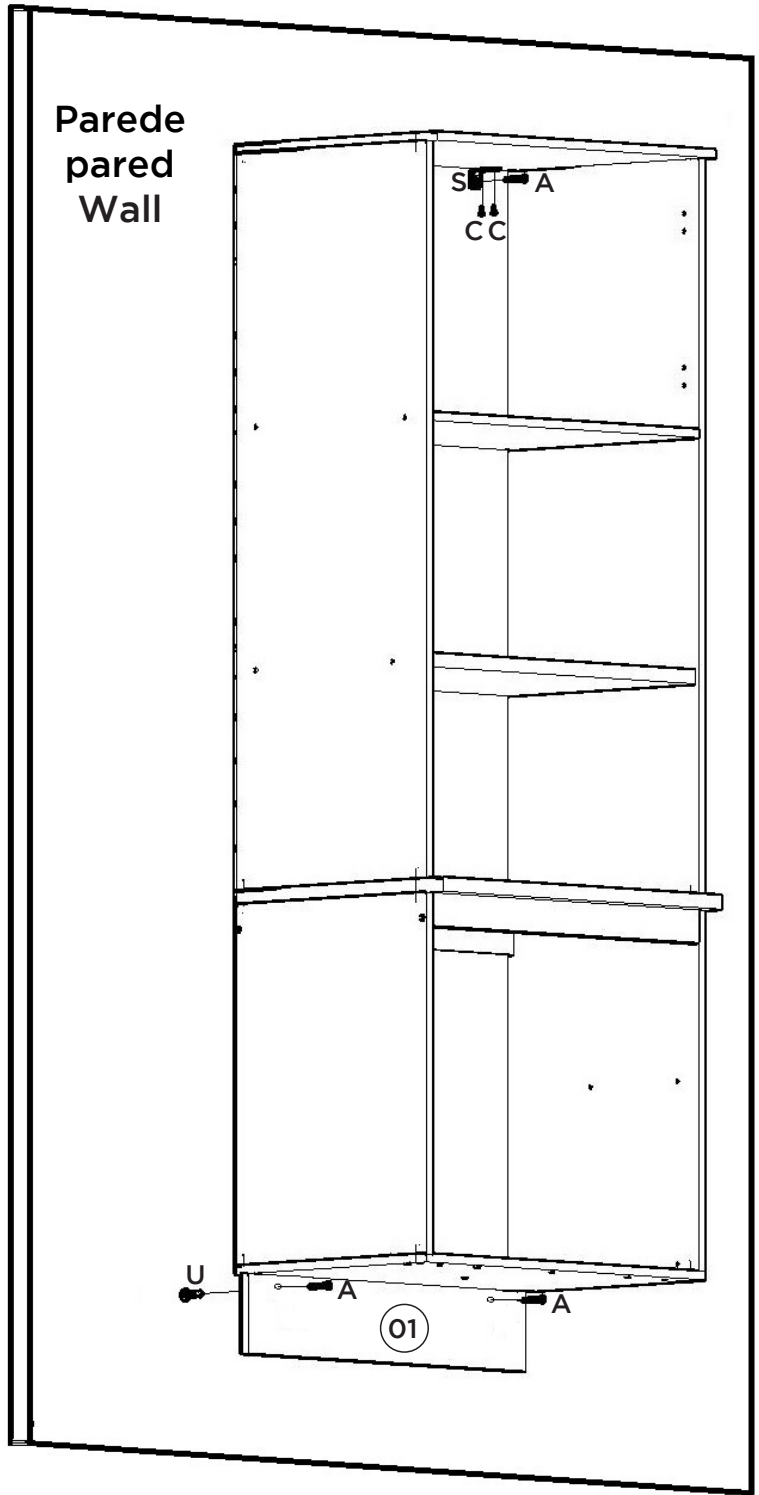

Para a desmontagem da corredeira siga a instrução ao lado.

Para el desmontaje seguimiento de diapositivas la instrucción siguiente a.

For the dismount of the sliding onem follows the instruction aside.

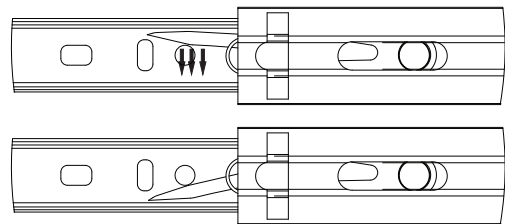

Fixar as corredeças nessas furações  
 Fijar las diapositivas de estos agujeros  
 Fix slides in these drillings

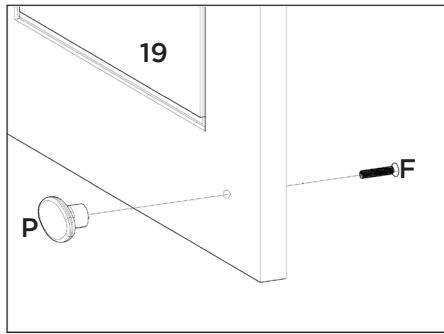

Para colocação dos puxadores, é necessário fazer a furação passante, com Broca de 5mm.

Para la colocación de las asas, es necesario perforar a través, con una broca de 5mm.

To place the handles is necessary to make the through hole, drill 5mm.

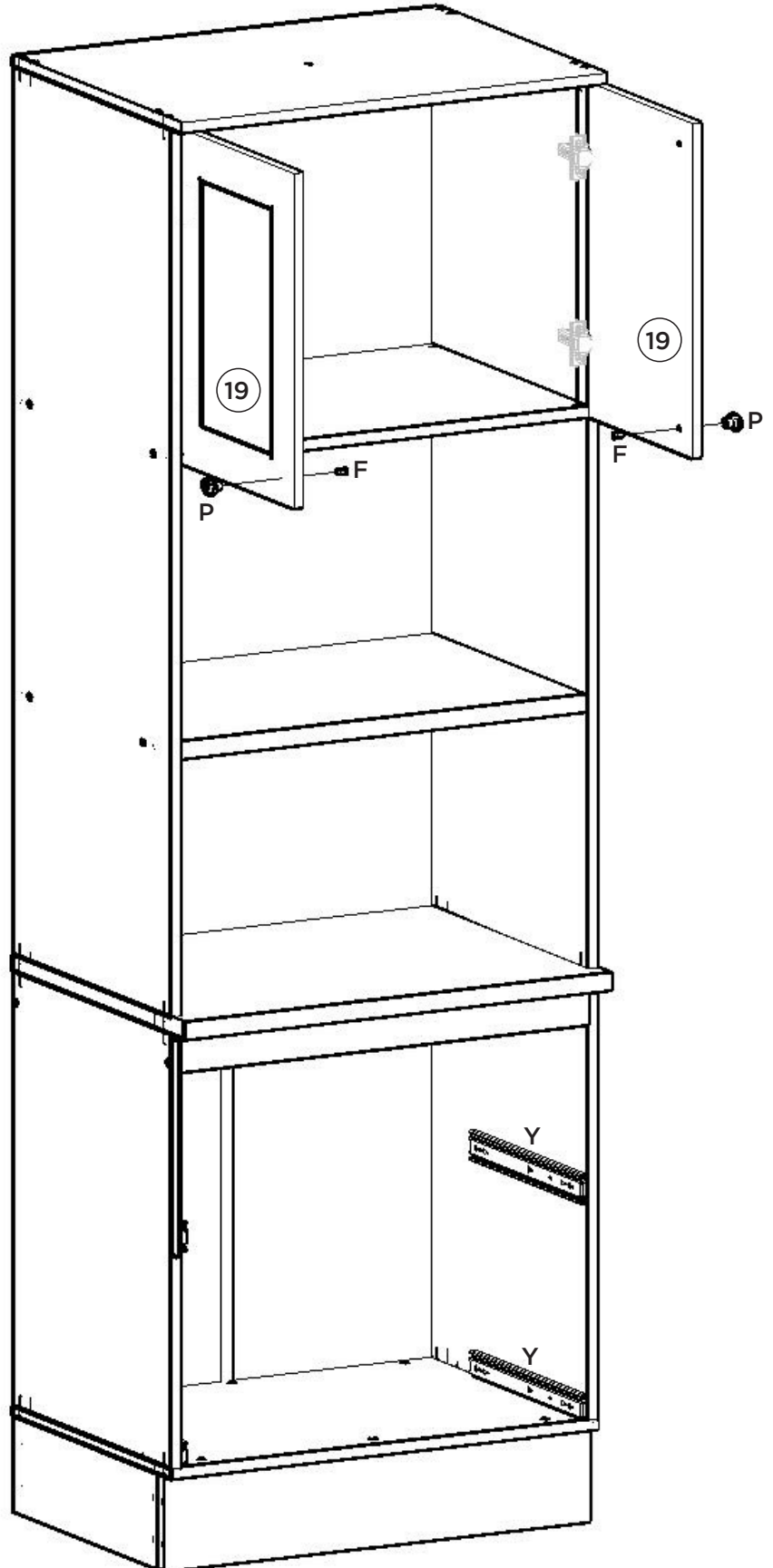
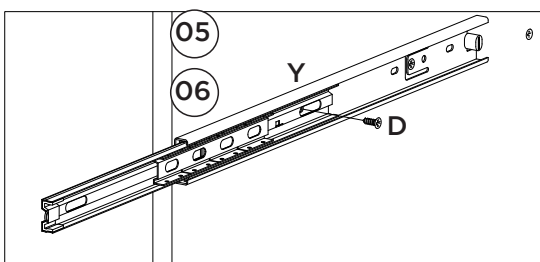
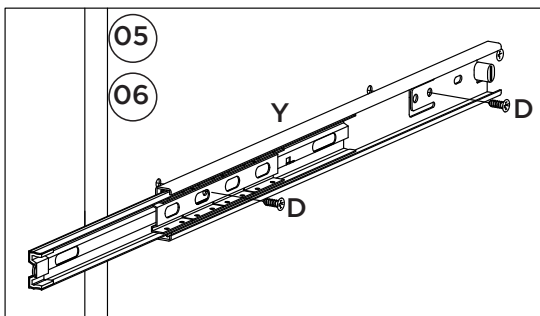
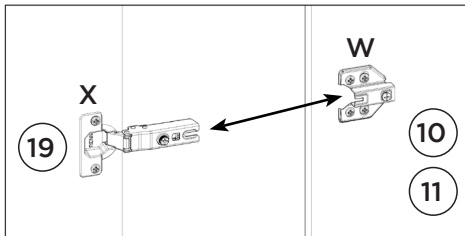
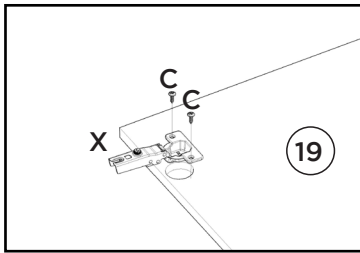
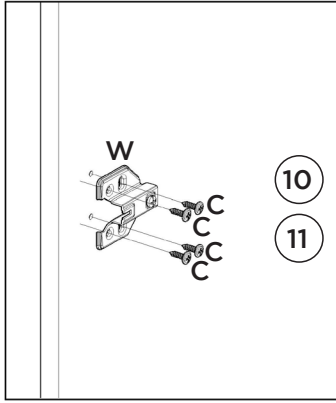

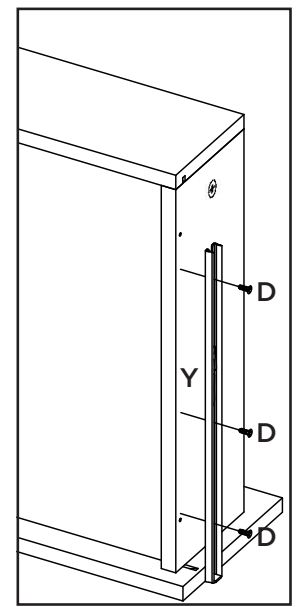
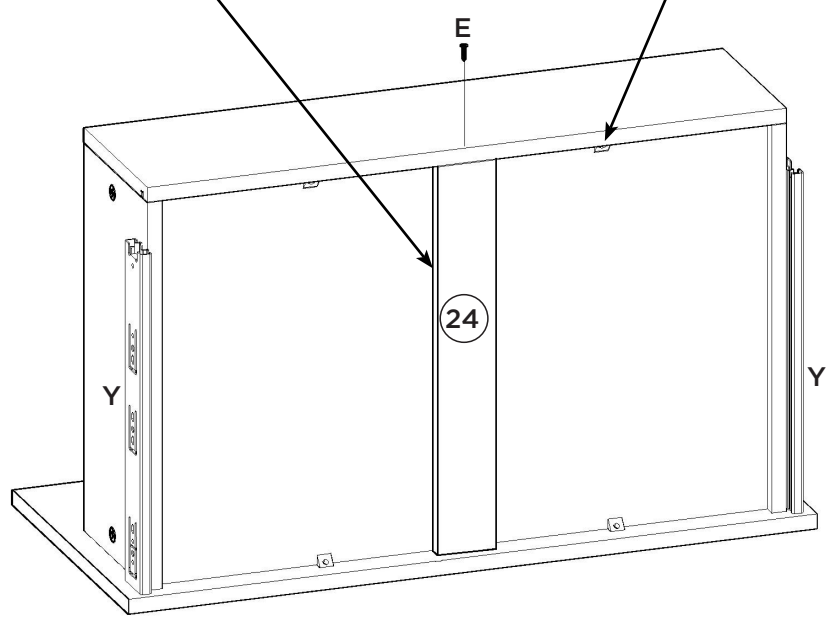
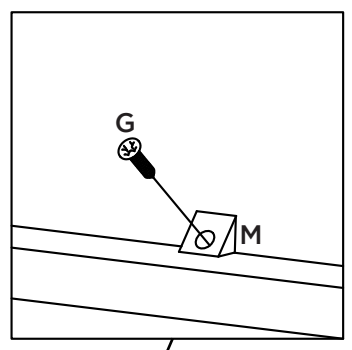
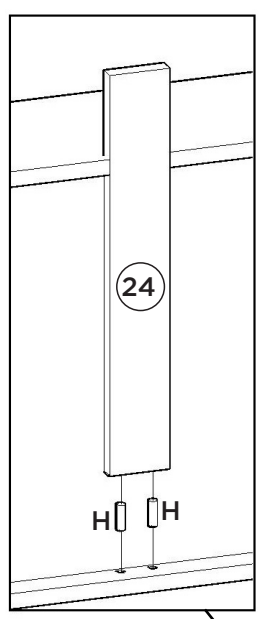
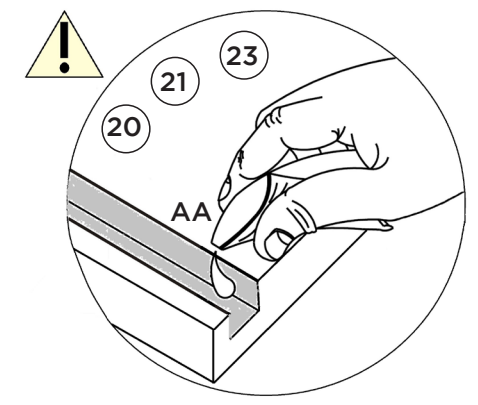
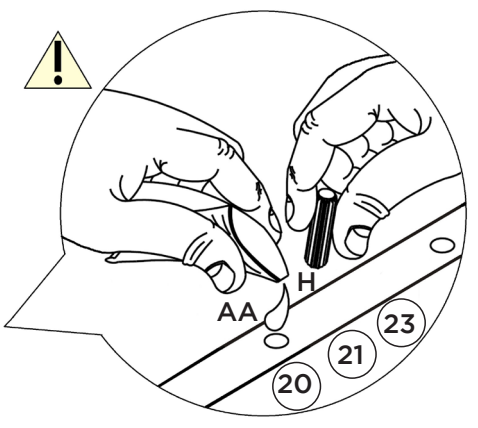
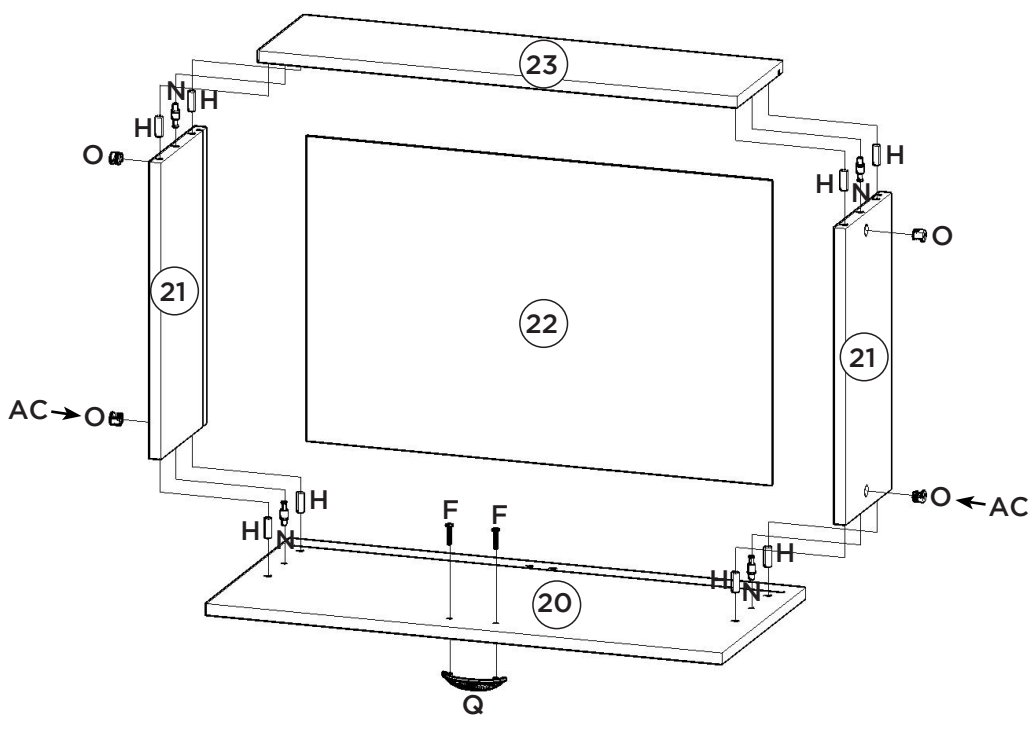







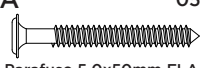
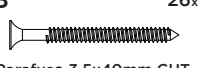
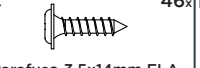
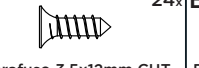
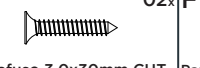

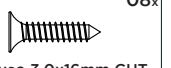

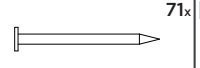
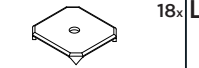

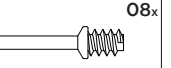



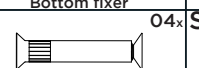

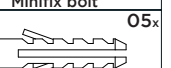
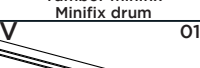

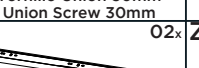
Lista de Peças | Lista de piezas | List of parts

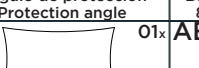
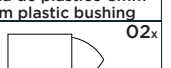
Item	Caixa Caja Box	Qty Ctd Qty	Descrição   Descripción   Description	Medidas (mm)   Dimensions (mm)   Size (measurements) (mm)
01	1/2	01	Rodapé Frontal   Frente pie de página   Front Footer	715x145x15
02	2/2	02	Rodapé Lateral   Pie de página Side   Side Footer	450x145x15
03	1/2	01	Rodapé Traseiro   Pie de página trasera   Rear Footer	683x145x15
04	2/2	01	Base   Base   Base	715x490x15
05	1/2	01	Lateral Esquerda Inferior   Lateral Izquierda Inferior   Left Side Lower	660x490x15
06	1/2	01	Lateral Direita Inferior   Lateral Derecha Inferior   Right Side Bottom	660x490x15
07	1/2	01	Travessa frontal   Travesaño frontal   Front crossbar	684x60x15
08	1/2	01	Travessa traseira   Travesaño trasero   Rear bumper	684x60x15
09	2/2	01	Tampo 25mm   Tapa 25mm   25mm Top	715x533x25
10	1/2	01	Lateral Esquerda Superior   Lateral Izquierda Superior   Upper Left Side	1345x490x15
11	1/2	01	Lateral Direita Superior   Lateral Derecha Superior   Right Side Superior	1345x490x15
12	2/2	01	Prateleira 25mm   Estantería 25mm   Shelf 25mm	684x480x25
13	2/2	01	Prateleira Central   Estantería central   Central Shelf	684x490x15
14	2/2	01	Tampo   Tapa   Top	715x517x15
15	2/2	01	Fundo Superior   Fondo superior   Superior background	708x272x3
16	2/2	01	Fundo Central Maior   Fondo Central Mayor   Major Central Fund	708x447x3
17	2/2	01	Fundo central   Fondo central   Central fund	708x405x3
18	2/2	02	Fundo Cru   Fondo Crudo   Raw Background	687x353x3
19	1/2	02	Porta Menor   Puerto Menor   Less door	508x354x15
20	1/2	02	Frente de gaveta   Frente de cajón   Front of drawer	711x330x15
21	1/2 e 2/2	04	Lado de Gaveta   Lado del cajón   Drawer Side	400x180x15
22	1/2	02	Fundo de gaveta   Fondo de cajón   Bottom of drawer	640x411x3
23	2/2	02	Ripa de trás   Malla detrás   Rear lath	659x180x15
24	2/2	02	Ripa Estrutural Gaveta   Ripa Estructural Cajón   Drawer Structural Clamp	400x60x15

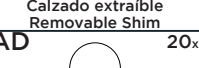
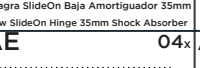
Ferragens | Herrajes | Hardware

<b>A</b> 05x  Parafuso 5,0x50mm FLA. Tornillo 5,0x50mm FLA. Screw 5,0x50mm FLA.	<b>B</b> 26x  Parafuso 3,5x40mm CHT. Tornillo 3,5x40mm CHT. Screw 3,5x40mm CHT.	<b>C</b> 46x  Parafuso 3,5x14mm FLA. Tornillo 3,5x14mm FLA. Screw 3,5x14mm FLA.	<b>D</b> 24x  Parafuso 3,5x12mm CHT. Tornillo 3,5x12mm CHT. Screw 3,5x12mm CHT.	<b>E</b> 02x  Parafuso 3,0x30mm CHT. Tornillo 3,0x30mm CHT. Screw 3,0x30mm CHT.	<b>F</b> 06x  Parafuso M4x20mm CHT. ZB Tornillo M4x20mm CHT. ZB Screw M4x20mm CHT. ZB	<b>G</b> 08x  Parafuso 3,0x16mm CHT. Tornillo 3,0x16mm CHT. Screw 3,0x16mm CHT.
<b>H</b> 60x  Cavilha 8x25mm Cinta 8x25mm Dowel 8x25mm	<b>I</b> 04x  Prego 12x12mm Anelado Clavo 12x12mm Anillado Ringed Nails 12x12mm	<b>J</b> 71x  Prego 10x10mm Clavo 10x10mm Nail 10x10mm	<b>K</b> 18x  Fixador de fundos Fijador de fondos Bottom fixer	<b>L</b> 08x  Cantoneira plástica Cantoneira plástica Plastic angle brackets	<b>M</b> 08x  Cantoneira suporte triangular Cantoneira soporte triangular Triangle support angle	<b>N</b> 08x  Parafuso minifix Tornillo minifix Minifix bolt
<b>O</b> 08x  Tambor minifix Tambor minifix Minifix drum	<b>P</b> 02x  Puxador Pontual PZ14 Oval Tirador Puntual PZ14 Oval PZ14 Oval Point Knob	<b>Q</b> 02x  Puxador Concha Tirador Concha Shell Handle	<b>R</b> 04x  Parafuso União 30mm Tornillo Unión 30mm Union Screw 30mm	<b>S</b> 03x  Suporte de fixação Soporte de fijación Mounting bracket	<b>T</b> 03x  Proteção para cantoneira Ángulo de protección Protection angle	<b>U</b> 05x  Buchas plásticas 8mm Bucha de plástico 8mm 8mm plastic bushing
<b>V</b> 01x  Perfil "I" 672mm Perfil "I" 672mm Profile "I" 672mm	<b>W</b> 04x  Calço Removível Calzado extraíble Removable Shim	<b>X</b> 04x  Dobradica SlideOn Baixa Amortecedor 35mm Bisagra SlideOn Baja Amortiguador 35mm Low SlideOn Hinge 35mm Shock Absorber	<b>Y</b> 02x  Corrediza telescópica Diapositivas telescópicas Telescopic slides	<b>Z</b> 04x  Sapata "L" 16x20mm Zapata "L" 16x20mm "L" shoe 16x20mm	<b>AA</b> 01x  Sachê de cola Bolsa de pegamento Glue bag	<b>AB</b> 02x  Giz de correção Tiza de corrección Chalk of correction
<b>AC</b> 04x  Adesivo tapa parafuso 17mm Adhesivo tapón de tornillo 17mm Bolt cover adhesive 17mm	<b>AD</b> 20x  Adesivo tapa parafuso 10mm Adhesivo tapón de tornillo 10mm Bolt cover adhesive 10mm	<b>AE</b> 04x  Parafuso 4,5x50mm CHT. Tornillo 4,5x50mm CHT. Screw 4,5x50mm CHT.	<b>AF</b> 01x  Etiqueta resinada Henn Etiqueta resinada Henn Henn resin label			

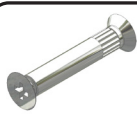

O parafuso (R) deve ser usada somente quando este módulo for acoplado a outro módulo componível Henn.

RECOMENDAÇÃO

Para fixar o móvel na parede usar o suporte de fixação (S), o parafuso 3,5x14mm FLA (C), a Bucha 8mm (U) e o parafuso 5,0x50mm FLA (A).

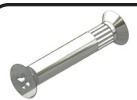

El tornillo (R) se debe utilizar sólo cuando el módulo está conectado a otro módulo componible Henn.

RECOMENDACIÓN

Para conectar el móvil a la pared con el soporte (S), tornillo 3,5 x14mm FLA (C), el casquillo de 8 mm (U) y el 5,0 x50mm tornillo FLA (A).

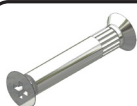

The screw (R) should be used only when this module is attached to another Henn modular module.

RECOMMENDATION

To fix the furniture to the wall use the mounting bracket (S), the 3.5x14mm FLA (C) screw, the 8mm bushing (U) and the 5.0x50mm FLA (A).