

MANUAL DE MONTAGEM / ASSEMBLY INSTRUCTIONS / PLANO DE ARMADO

Antes de montar o móvel, leia com atenção o manual de montagem!
Before assembling the furniture, carefully read the assembly instructions!
Antes de armar el mueble, lea con atención el manual de ensamble!

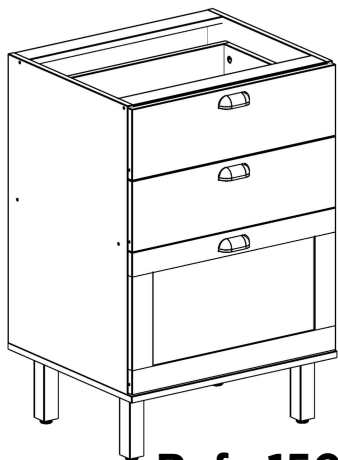

Ref.: 1504 - 1527

genialflex
ambientes incríveis para todos

Parabéns! Você comprou um produto de excelente qualidade, fabricado com chapa de madeira de MDP ou MDF, extraída de florestas renováveis. Possui alta resistência e design atual.

Congratulations! You have purchased a product of excellent quality, made from MDP or MDF wood veneer, extracted from renewable forests. It has high strength and current design.

Felicitaciones! Usted compró a un producto de excelente calidad, fabricado con placa de madera de MDP o MDF, proveniente de florestas renovables. Tiene alta resistencia y diseño actual.



ATENÇÃO
ATTENTION
ATENCIÓN

1) Verifique todas as peças antes de começar a montagem.

Check all parts before starting assembly.

Verifique todas las partes antes de empezar el armado.

2) Ao começar a montagem, não apoie as peças na parede.

When starting the assembly, do not support the parts on the wall.

Al empezar el armado, no apoyes las partes en la pared.

3) Ao colocar as peças e ferragens de lado, cuidado para não perde-las.

When placing parts and hardware aside, be careful not to lose them.

Al poner las piezas y herrages a parte, cuidado para no dañarlas.

4) O móvel deve ser montado no chão, para isso, use a própria caixa para proteger e não danificar o piso.

The furniture must be mounted on the floor, to do this, use the box itself to protect and not damage the floor.

El mueble suele ser armado al piso, para eso, use la propia caja para protegerlo y no dañar al piso.

5) Comece a montagem seguindo as instruções passo a passo.

Begin assembly by following the step-by-step instructions.

Comience el armado siguiendo la instrucciones paso a paso.

6) É de responsabilidade do montador seguir as intruções desse manual, que são fundamentais para a estrutura do móvel.

It's the assembler's responsibility to follow the instructions in this manual, which are fundamental to the structure of the furniture.

Es de responsabilidad del armador seguir las instrucciones de este manual, que son fundamentales para la estructura del mueble.

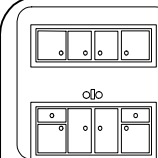

CUIDADOS
CARE
CUIDADO

1) A conservação e limpeza deve ser feita com um pano levemente umedecido com água.

Care and cleaning should be done with a cloth slightly moistened with water.

La conservación y limpieza debe ser hecha con un trapo levemente humedecido en agua.

2) Não use produtos abrasivos, como saponáceo, detergentes e esponja de aço.

Do not use abrasive products, such as soap, detergents and steel sponge.

No use productos abrasivos, como saponáceo, detergentes y esponja de acero.

3) Não use cera ou óleo para dar brilho ao móvel.

Do not use wax or oil to shine the furniture.

No use cera o aceites para darle brillo al mueble.

4) Não expor o móvel a intempéries e nem ao calor excessivo.

Do not expose the furniture to weather or excessive heat.

No exponer el mueble a interperies ni al calor excesivo.

5) Ao terminar a montagem, limpe o ambiente e o móvel.

When the assembly is finished, clean the room and the furniture.

Al terminar el armado, limpie al ambiente y al mueble.

FERRAMENTAS / TOOLS / HERRAMIENTAS



MARTELO
HAMMER
MARTILLO



MARTELO DE BORRACHA
RUBBER HAMMER
MARTILLO GOMA



CHAVE PHILLIPS
PHILLIPS SCREWDRIVER
LLAVE PHILLIPS



TRENA
MEASURING TAPE
CINTA MÉTRICA









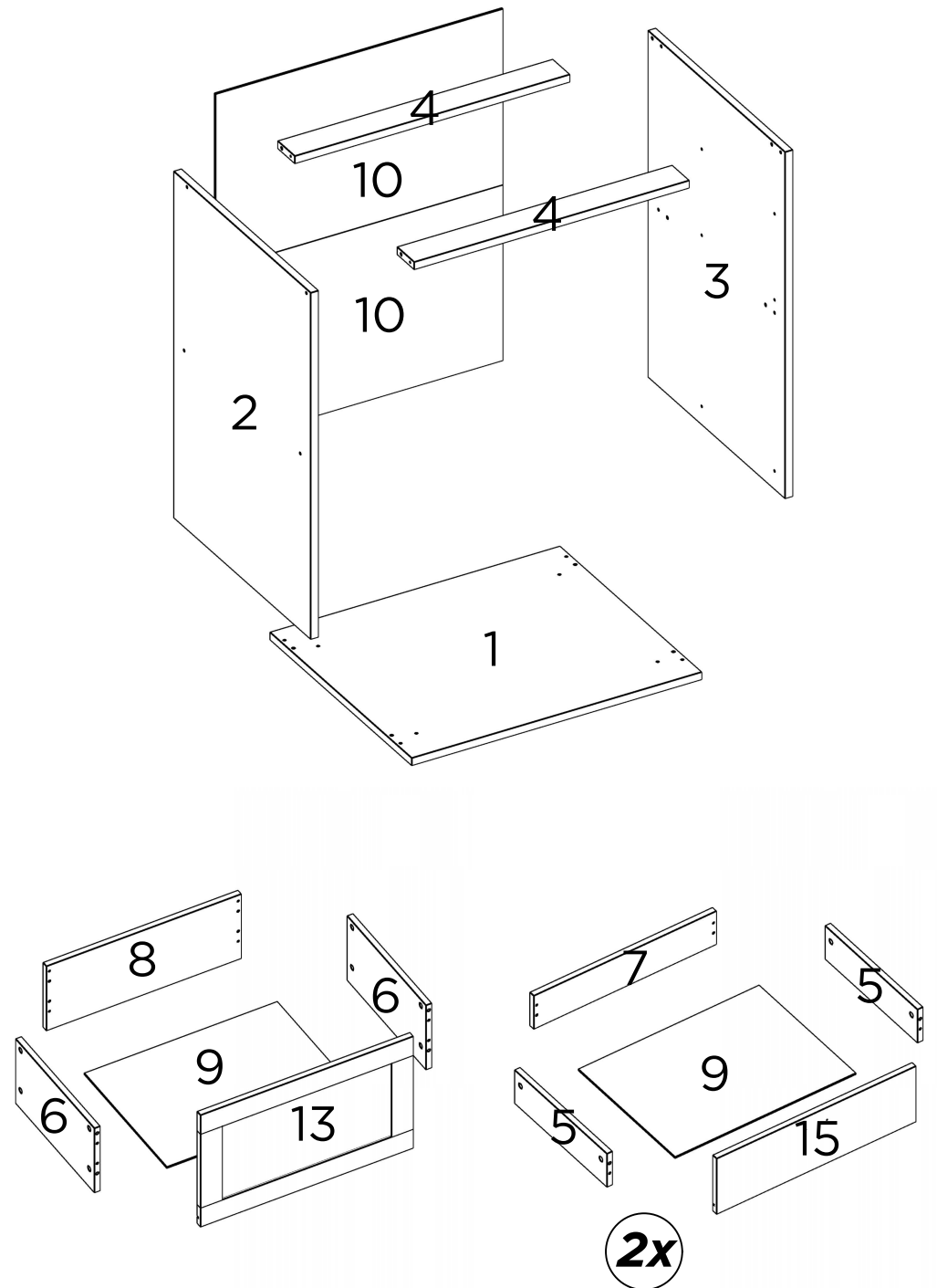



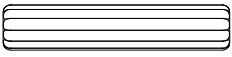

PARAFUSADEIRA
DRILL/ELECTRIC
SCREWDRIVER
DESTORNILLADOR
ELÉCTRICO

PEÇAS / PARTS / PIEZAS

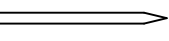
Nº No Num	DESCRIÇÃO DESCRIPTION DESCRIPCIÓN	QTD QTY CANT
1	BASE BOTTOM BASE	1
2	LATERAL ESQUERDA LEFT SIDE PANEL LATERAL IZQUIERDA	1
3	LATERAL DIREITA RIGHT SIDE PANEL LATERAL DERECHA	1
4	TRAVESSA FRONTAL FRONTAL PLATE TRAVESAÑO FRONTAL	2
5	LATERAL DE GAVETA DRAWER SIDE LATERAL DEL CAJÓN	4
6	LATERAL DE GAVETA MAIOR LARGER DRAWER SIDE LATERAL DEL CAJÓN MAYOR	2
7	COSTA DE GAVETA DRAWER BACK TRASERO DEL CAJÓN	2
8	COSTA DE GAVETA MAIOR LARGER DRAWER BACK TRASERO DEL CAJÓN MAYOR	1
9	FUNDO DE GAVETA DRAWER BOTTOM PANEL FONDO DEL CAJÓN	3
10	COSTA BACK PANEL TRASERO	2
13	FRENTE DE GAVETA MAIOR LARGER DRAWER FRONT FRENTE DEL CAJÓN MAYOR	1
15	FRENTE DE GAVETA DRAWER FRONT FRENTE DEL CAJÓN	2

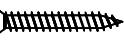
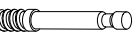

FERRAGENS / HARDWARE / HERRAJES

CÓD CODE COD	DESCRIÇÃO DESCRIPTION DESCRIPCIÓN	QTD QTY CANT
A	 CAVILHA WOODEN DOWEL TARUGO	24
B	 PARAFUSO 4X14mm SCREW 4X14mm TORNILLO 4X14mm	24
C	 CORREDIÇA SLIDE CORREDERA	3
D	 PARAFUSO 5X50mm SCREW 5X50mm TORNILLO 5X50mm	4
E	 PÉ LEG PATA	4
F	 PARAFUSO 3,5X40mm SCREW 3,5X40mm TORNILLO 3,5X40mm	8
G	 PREGO NAIL CLAVO	26
H	 PREGO ANELADO RINGED NAIL CLAVO ANILLADO	36
I	 PARAFUSO 3,5X25mm SCREW 3,5X25mm TORNILLO 3,5X25mm	9
J	 PARAFUSO MINIFIX MINIFIX SCREW TORNILLO MINIFIX	16
K	 TAMBOR MINIFIX MINIFIX DRUM TAMBOR MINIFIX	16
M	 PUXADOR PULLER TIRADOR	3
O	 TAPA-FURO MAIOR BIGGER HOLE COVER TAPA AGUJERO MAYOR	16
P	 TAPA-FURO MENOR SMALL HOLE COVER TAPA AGUJERO MINOR	8

UTILIZE A RÉGUA PARA IDENTIFICAR OS PARAFUSOS
USE THE RULER TO IDENTIFY THE SCREWS
UTILICE LA REGLA PARA IDENTIFICAR LOS TORNILLOS

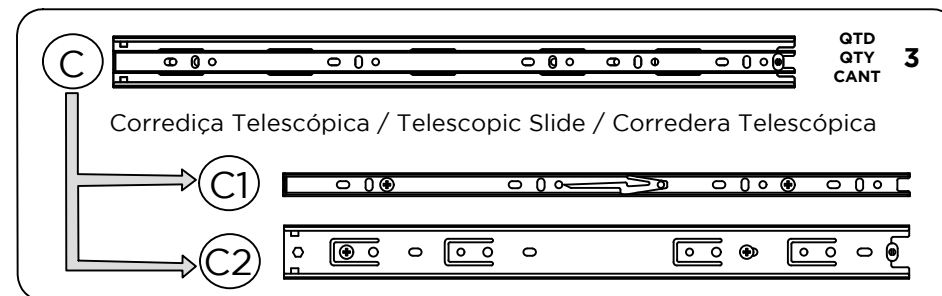

PESO SUPORTADO / WEIGHT SUPPORTED / PESO SOPORTADO

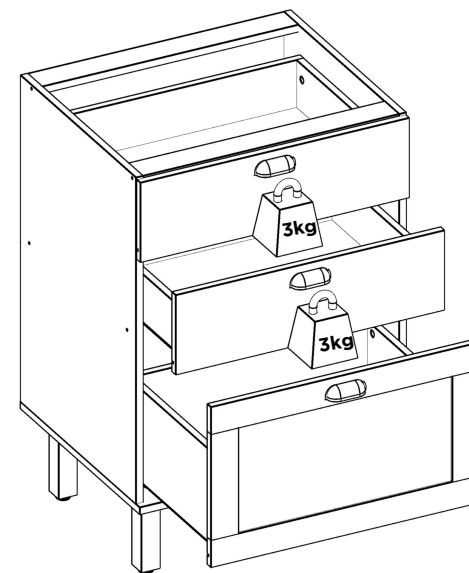

7

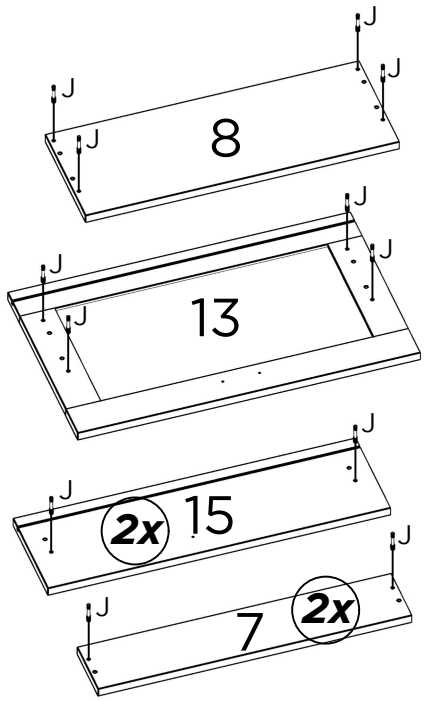

8

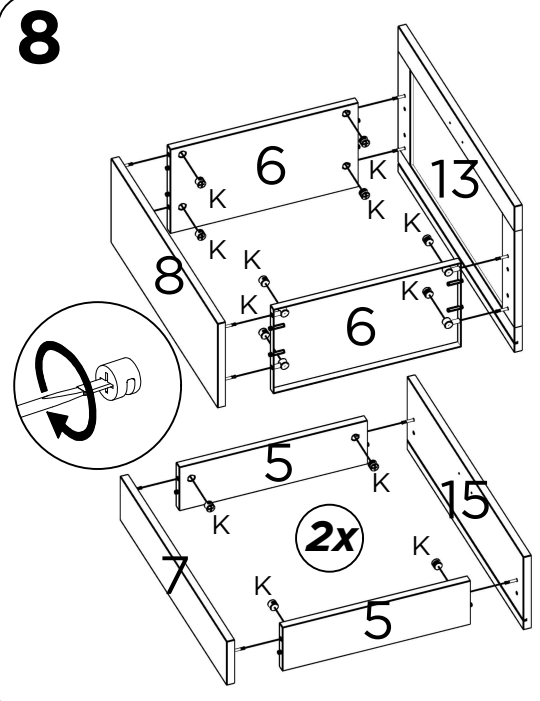

9

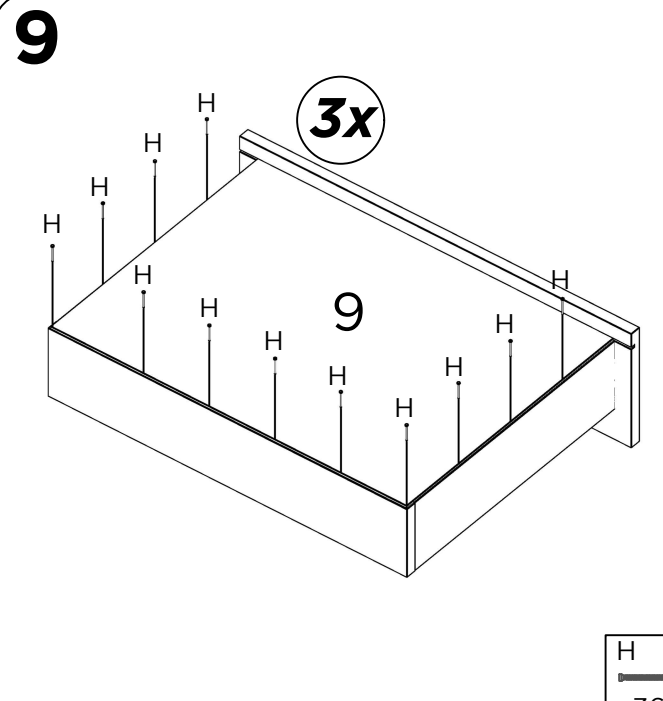

10

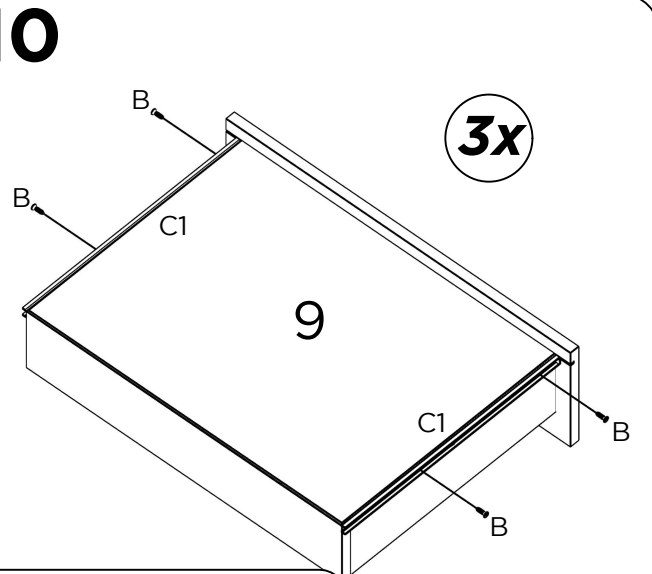

SIGA AS INSTRUÇÕES NA PÁGINA DA CORREDIÇA.
FOLLOW THE INSTRUCTIONS ON THE SLIDE PAGE.
SIGA LAS INSTRUCCIONES EN LA PÁGINA DE LA CORREDERA.

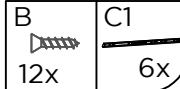

11

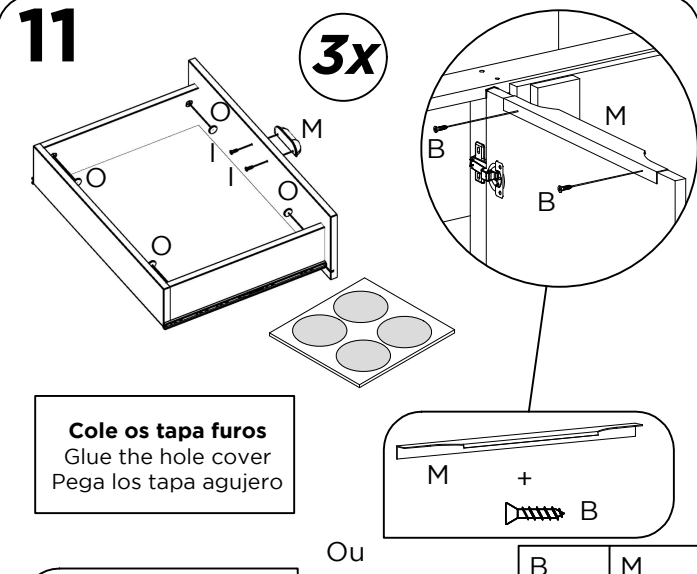

Cole os tapa furos
Glue the hole cover
Pega los tapa agujero

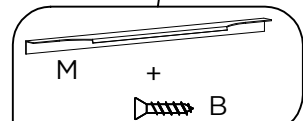
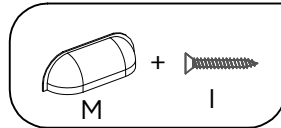

O	B	M
16x	6x	3x
I	M	
6x	3x	

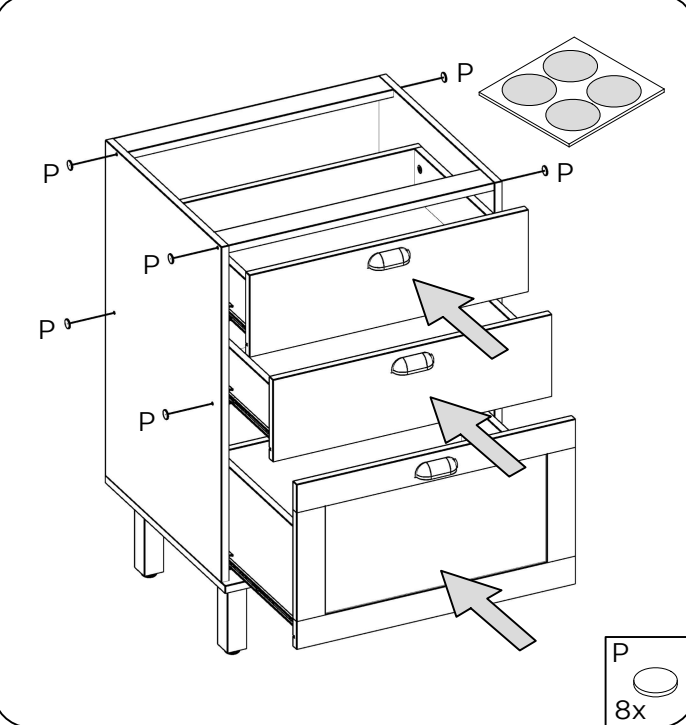

Para instalar as corrediças telescópicas é necessário seguir os passos, separando as partes que compõem a corrediça.

To install the telescopic slides, it is necessary to follow the steps, separating the parts that make up the slide.

Para instalar las correderas telescópicas es necesario seguir los pasos, separando las dos partes que componen la pieza.

Corrediça telescópica / Telescopic slides Corredera telescópica



Passo 1 / Step 1 / Paso 1

Corrediça telescópica aberta / Telescopic slide open / Corredera telescópica abierta

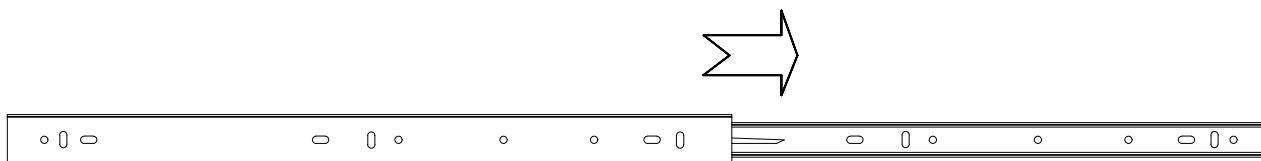

Para separar as partes da corrediça, puxe o engate que está na parte traseira da corrediça (desenho ao lado) no sentido anti-horário, separando as duas partes, para facilitar a fixação no móvel.

To separate the parts of the slide, pull the hook on the back of the slide (illustration on the side) counterclockwise, separating the two parts, to facilitate attachment to the furniture.

Para separar las dos partes de la corredera, tire el engate que está en la parte de atrás de la corredera (dibujo al lado) en el sentido anti-horario, separando las dos partes, para facilitar la fijación en el mueble.

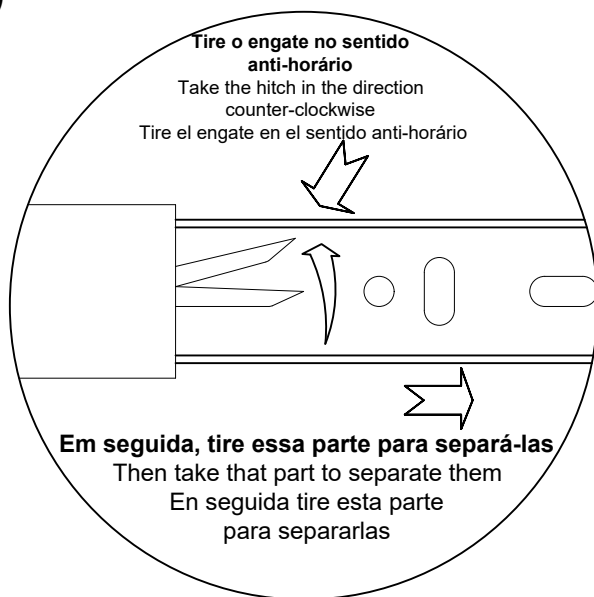
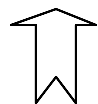

Passo 2 / Step 2 / Paso 2

Com as partes da corrediça separadas, fixar-las no móvel.

With the slide parts separated, fix them to the furniture.

Con las partes de la corredera separadas, fijarlas en el mueble.

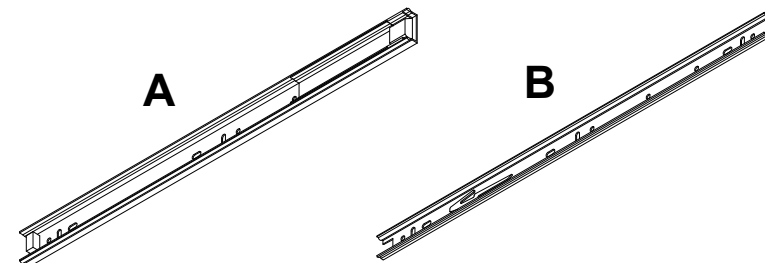

As corrediças devem ficar alinhadas com a parte inferior das laterais de gavetas.

The slide should be flush with the underside of the drawer sides.

Las correderas deben quedar aliñada con la parte inferior de las laterales de los cajones.

