

Linha: Sala

Mod.: Home Susp. Emborriú

Cód.: 1.634

 FERRAMENTAS  
PARA MONTAGEM

2:30h

## ESQUEMA DE MONTAGEM ASSEMBLY INSTRUCTIONS ESQUEMA DE MONTAJE

Obs: Usar caixa de embalagem para forrar o chão na hora da montagem  
 Note: Use the packing box to cover the floor at the time of assembly  
 Nota: Utilice la caja de embalaje para cubrir el suelo en el momento del montaje

COLIBRI - IND. COM. DE MÓVEIS LTDA.  
 Rua Rouxinol, 5530 - Fone/Fax (43) 3275 - 8600  
 Pq. Industrial XI - CEP 86.706-418 - Arapongas - PR  
 E-mail: sac@colibrimoveis.com.br  
 Site: www.colibrimoveis.com.br



Para pedidos de Assistência Técnica agrupar a Referência da Peça com N.º da Cor. Ex: 1634A0.001.660 (Prateleira sup na cor Preto)

Cód.	Referência	Cor	Preto/Noce	Peças	Qt.	Medidas	M.P.	Piece	Pieza
01	1634A0.001	660		Prateleira superior	1	1996x150x25	MDP	Top shelf	Estante mayor
02	1634A0.002	660		Tampo	1	1998x305x15	MDP	Cubierta	Cubierta
03	1634A0.003	660		Base	1	1998x305x15	MDP	Base	Base
04	1634A0.004	660		Lateral esquerda	1	304x260x15	MDP	Right side	Lado derecha
05	1634A0.005	660		Divisão	2	304x260x15	MDP	Division	Division
06	1634A0.006	660		Porta	3	656x270x15	MDP	Door	Puerta
07	1634A0.007	660		Lateral direita	1	304x260x15	MDP	Left side	Lado izquierdo
08	1634A0.008	660		Panel lateral	1	1260x668x15	MDP	Side panel	Panel lateral
09	1634A0.009	660		Panel superior	1	1332x420x15	MDP	Top panel	Panel superior
10	1634A0.010	660		Panel superior cen	1	1332x420x15	MDP	Top center panel	Panel central superior
11	1634A0.011	660		Panel inferior cen	1	1332x420x15	MDP	Bottom center panel	Panel central inferior
12	1634A0.012	660		Panel inferior	1	2000x358x15	MDP	Bottom panel	Panel inferior
13	1634A0.013	660		Travessa superior lat	2	1310x70x15	MDP	Travessa superior lat	Travesaño superior lat
14	1634A0.014	660		Travessa inferior lat	2	306x70x15	MDP	Travessa inferior lat	Travesaño inferior lat
15	1634A0.015	99		Travessa	2	720x70x15	MDP	Travessa	Travesaño
16	1634A0.016	99		Travessa central	2	720x70x15	MDP	Travessa	Travesaño
17	1634A0.017	99		Travessa fixação sup	1	1854x80x15	MDP	Central beam	Travesaño central
18	1634A0.018	99		Travessa fixação inf	1	1354x80x15	MDP	Travessa fixation sup	Travesaño fijación sup
19	1634A0.019	99		Travessa fixação sup men	2	540x80x15	MDP	Travessa fixation inf	Travesaño fijación sup men
20	1634A0.020	99		Travessa fixação inf men	2	540x80x15	MDP	Travessa fixation inf men	Travesaño fijación inf men

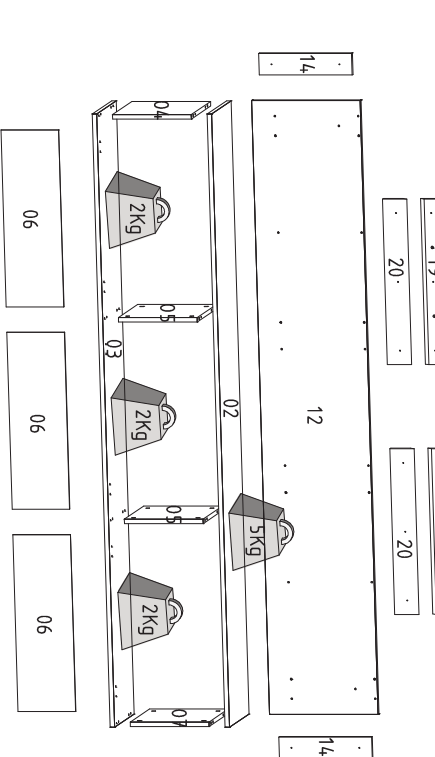

**Cuidados com a limpeza do móvel:**

Não molhar o móvel e não expor em lugar úmido.	Não expor o móvel próximo de fontes de calor.	Limpar apenas com pano limpo e levemente úmido
Do not wet the furniture and do not expose it in a humid place.	Do not expose this furniture close to sources of heat.	Clean the product using only a clean and slightly damp cloth.
No moje los muebles y no los esponga en un lugar húmedo.	No exponga el mueble cerca a fuentes de calor.	Limpiar solo con un paño limpio y ligeramente húmedo

A	B	C	D	E	F	G	H
40x	06x	68x	12x	08x	08x	13x	07x
08x	08x	08x	16x	06	06x	07x	03x
Parafuso 3,5x1/4 cod. 776	Parafuso 3,5x25 Ra cod. 789	Parafuso 4,0x25 cod. 780	Parafuso 4,0x40 cod. 781	Parafuso 4,0x50 cod. 782	Parafuso 5,0x70 cod. 792	Cavilha 8x20 cod. 5225	Cavilha 6x30 cod. 949
Porta cilíndrica cod. 163	Pino p/ Girofix cod. 162	Tambor 012 cod. 183	Tapa furo Preto cod. 4622	Dobr curva 26mm cod. 131	Calço 5mm cod. 939	Chapa reta & furos cod. 146	Puxador Lauren cod. 5216
01x	02x	13x	03x	12x	12x	12x	06x
Luminária cod. 954	Passa fio 40mm cod. 907	Bucha fixação Ø8 cod. 130	Sacne de cola cod. 166	Parafuso M4x25 cod. 808	Porta M4 bicr cod. 810	Parafuso 5,0x50 cod. 812	

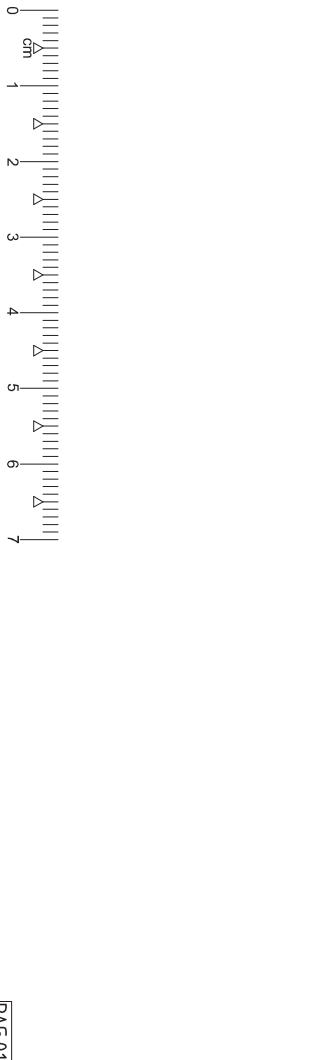

# ETAPAS DA MONTAGEM / STAGES OF THE ASSEMBLY / ETAPAS DE LA ASAMBLEA

Para uma montagem perfeita do produto, siga a sequência:

For a perfect product assembly, follow its sequence / Para un montaje perfecto del producto, sigue la secuencia.

- Passo 01**
- E 08x
  - H 20x
  - L 6x30
  - T 08x
  - U 08x

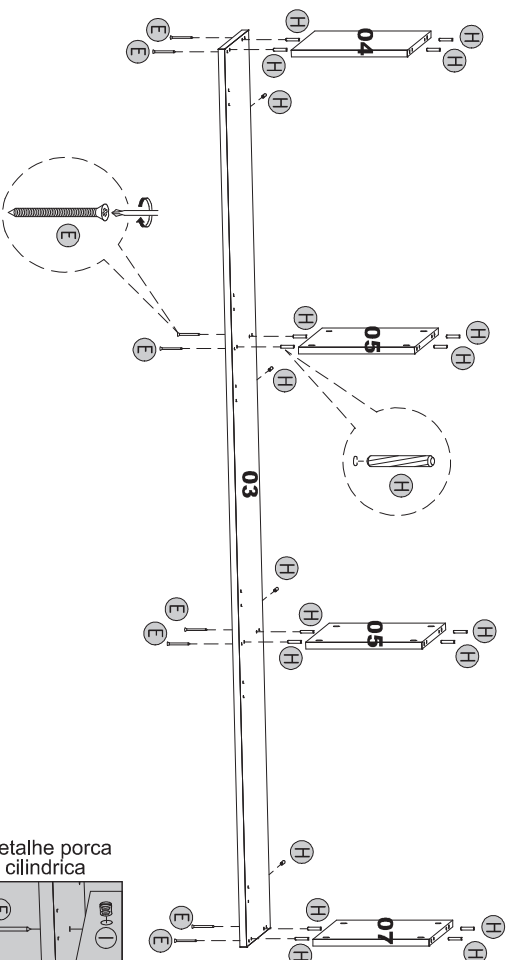

Nesse passo montar produto detizado

- Passo 02**
- N 06x
  - O 12x
  - P M4x25
  - Q 12x

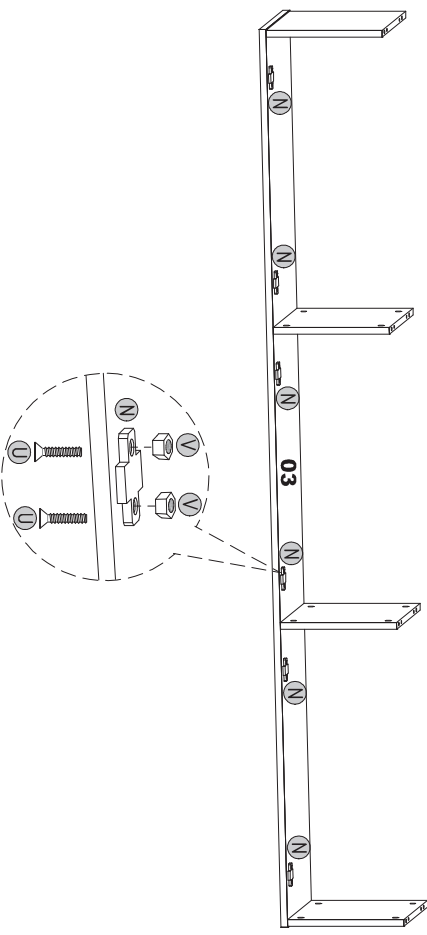

Nesse passo montar produto detizado



- Passo 03**
- H 04x
  - I 6x30
  - J 08x
  - K 08x
  - L 08x

1º Aplicar acessório "J" na peça 02

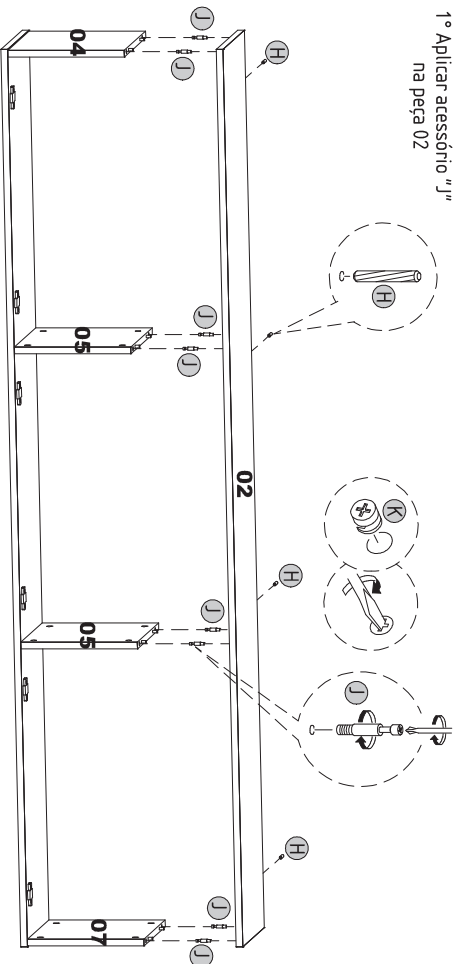

- Passo 04** Vista traseira
- D 12x
  - E 4,0x4,0

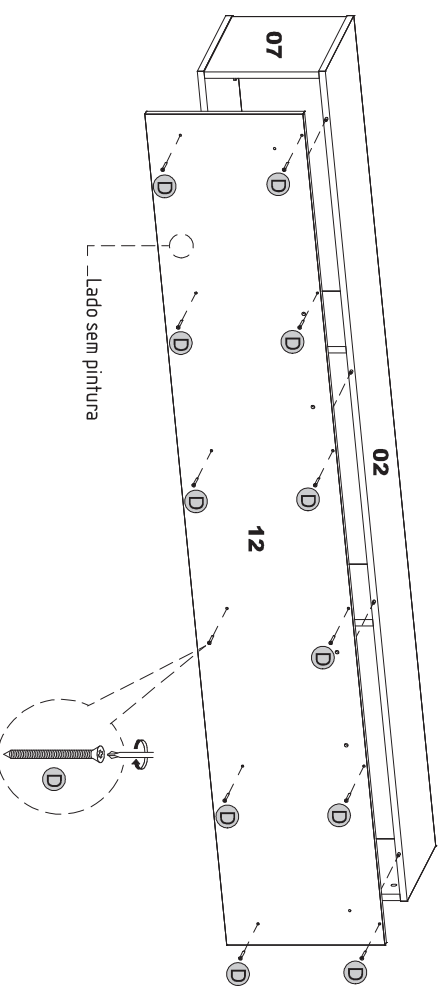

# ETAPAS DA MONTAGEM / STAGES OF THE ASSEMBLY / ETAPAS DE LA ASAMBLEA

Para uma montagem perfeita do produto, siga a sequência:

For a perfect product assembly, follow its sequence / Para un montaje perfecto del producto, sigue la secuencia.

Passo 05 Vista traseira

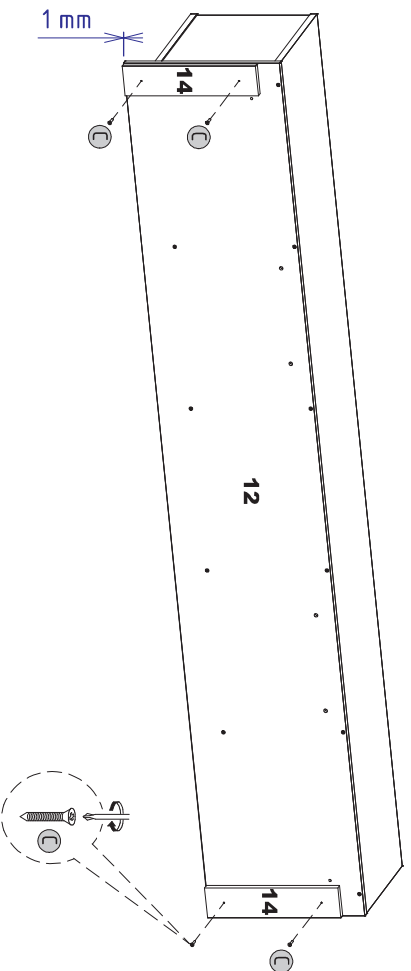
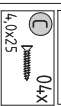

Passo 06 Vista traseira

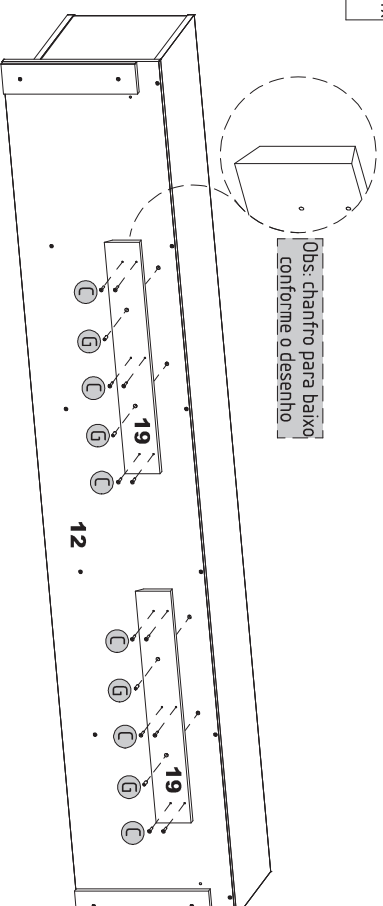
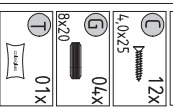

**ATENÇÃO: USO OBRIGATÓRIO DE COLA**

Passar cola no lado do chanfro

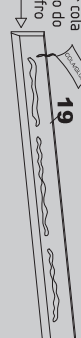

Passo 07 Vista traseira

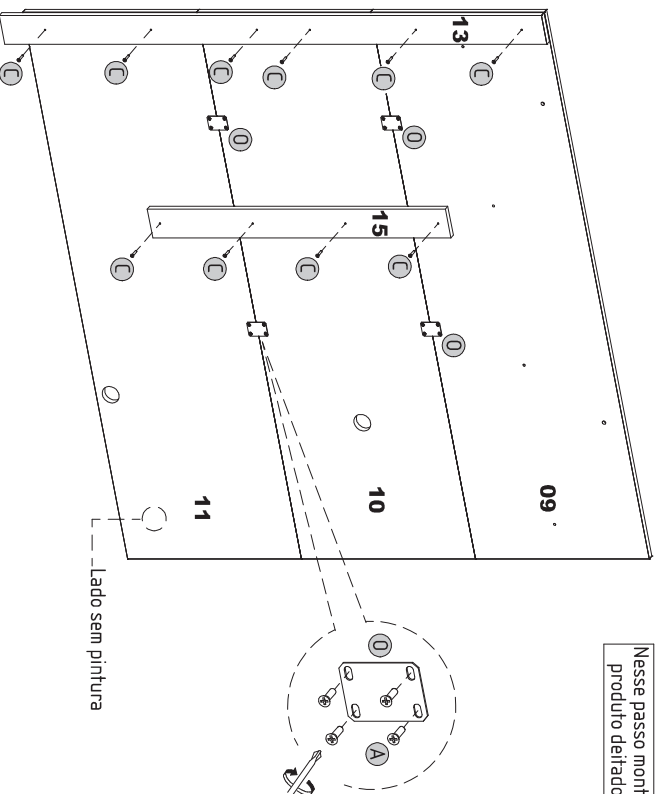
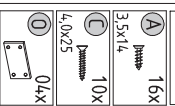

Passo 08 Vista traseira

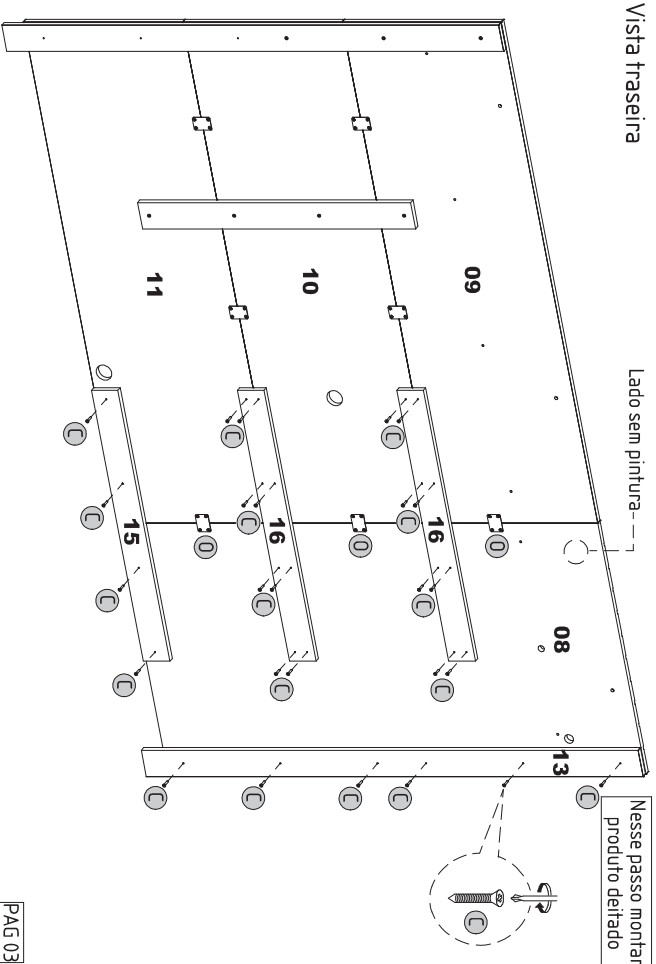
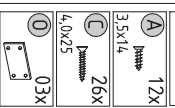

# ETAPAS DA MONTAGEM / STAGES OF THE ASSEMBLY / ETAPAS DE LA ASAMBLEA

Para uma montagem perfeita do produto, siga a sequência:

For a perfect product assembly, follow its sequence / Para un montaje perfecto del producto, sigue la secuencia.

## Passo 09 Vista traseira

- 16x 16x
- 4,0x25 4,0x25
- 03x 03x
- 8x20 8x20
- 02x 02x

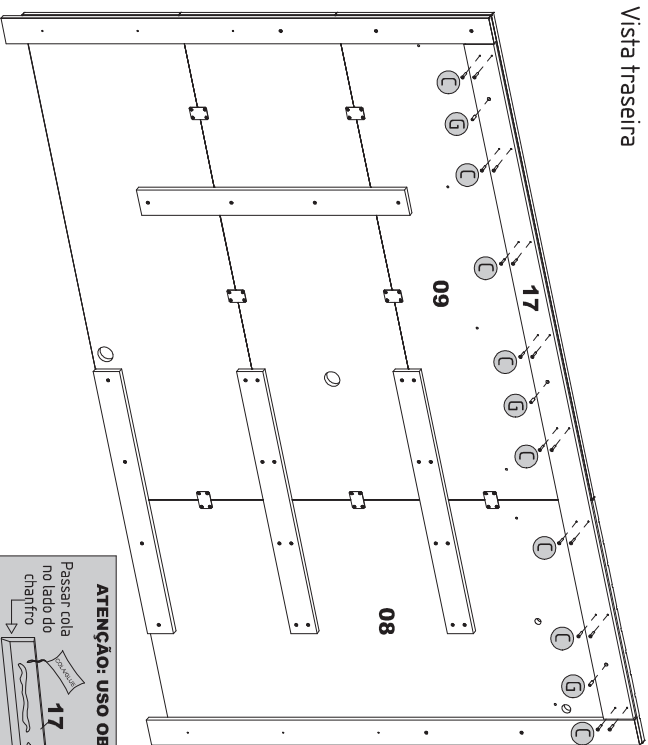

**ATENÇÃO: USO OBRIGATORIO DE COLA**  
 Passar cola no lado do chanfro  
 17

## Passo 10

- 06x 06x
- 4,0x40 4,0x40
- 04x 04x
- 5x30 5x30
- 06x 06x
- 5,0x50 5,0x50

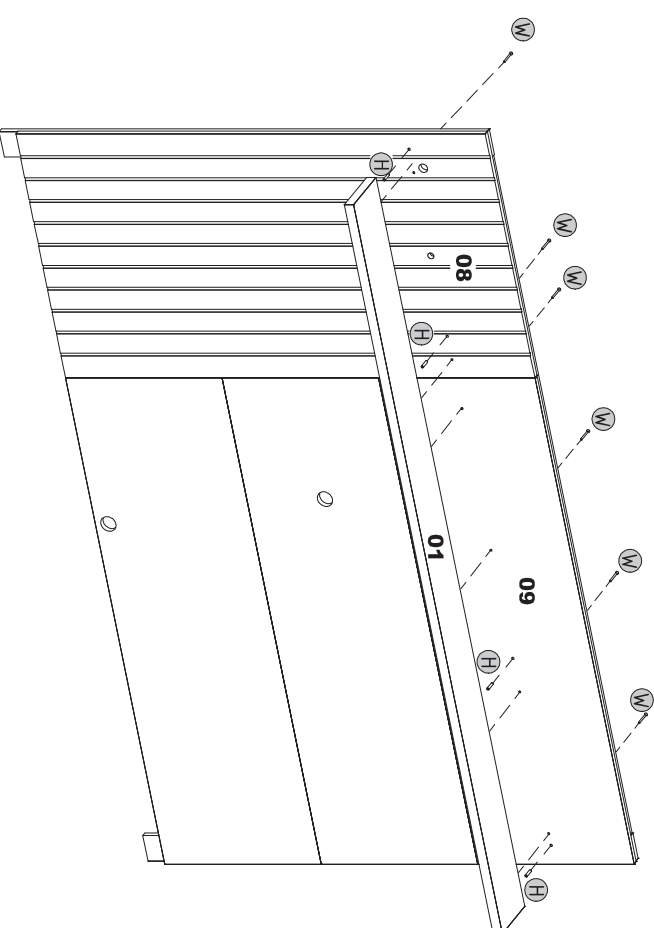

## Passo 11

- 01x 01x
- 02x 02x

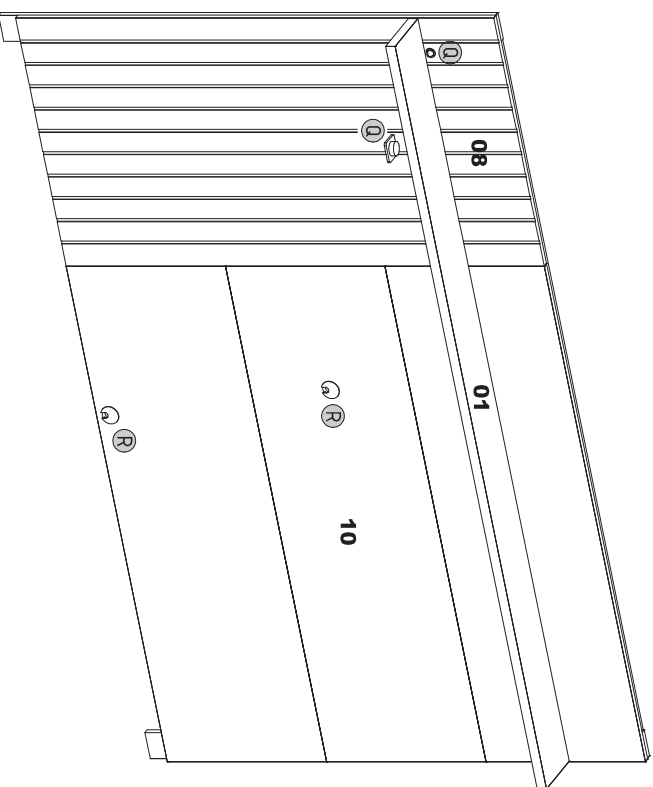

## Passo 12



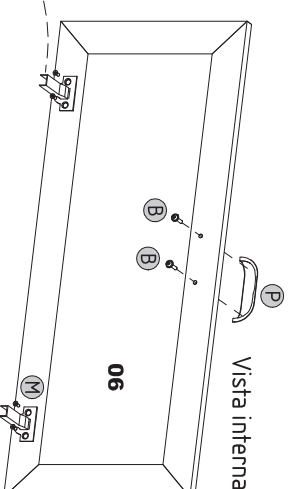
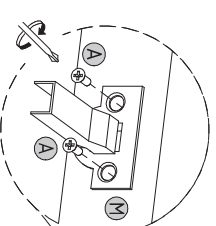
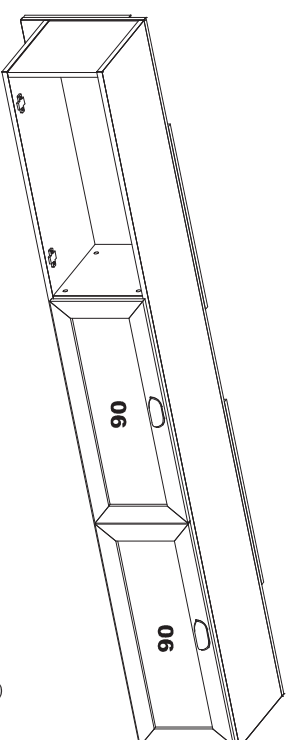

- 12x 12x
- 3,5x14 3,5x14
- 06x 06x
- 3,5x25 3,5x25
- 06x 06x
- 03x 03x







# ETAPAS DA MONTAGEM / STAGES OF THE ASSEMBLY / ETAPAS DE LA ASAMBLEA

Para uma montagem perfeita do produto, siga a sequência:

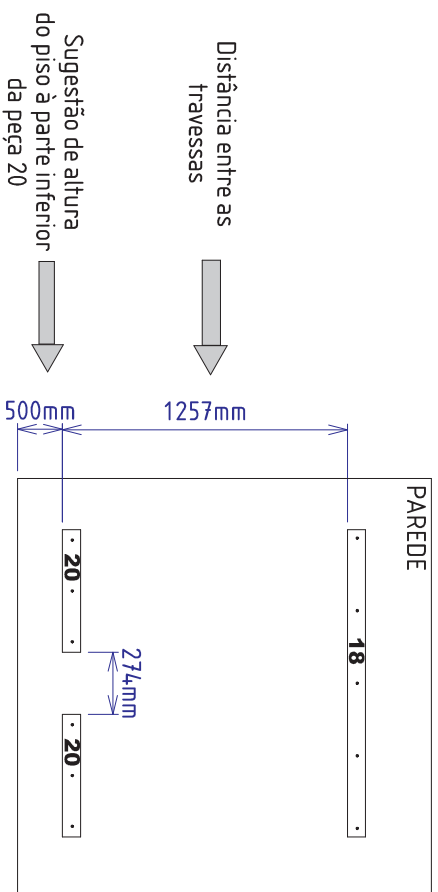
For a perfect product assembly, follow its sequence / Para un montaje perfecto del producto, sigue la secuencia.

**Passo 13**  
 11x  
 5.0x70  
 11x  



**Passo 14**  
 02x  
 5.0x70  
 02x  



PAREDE

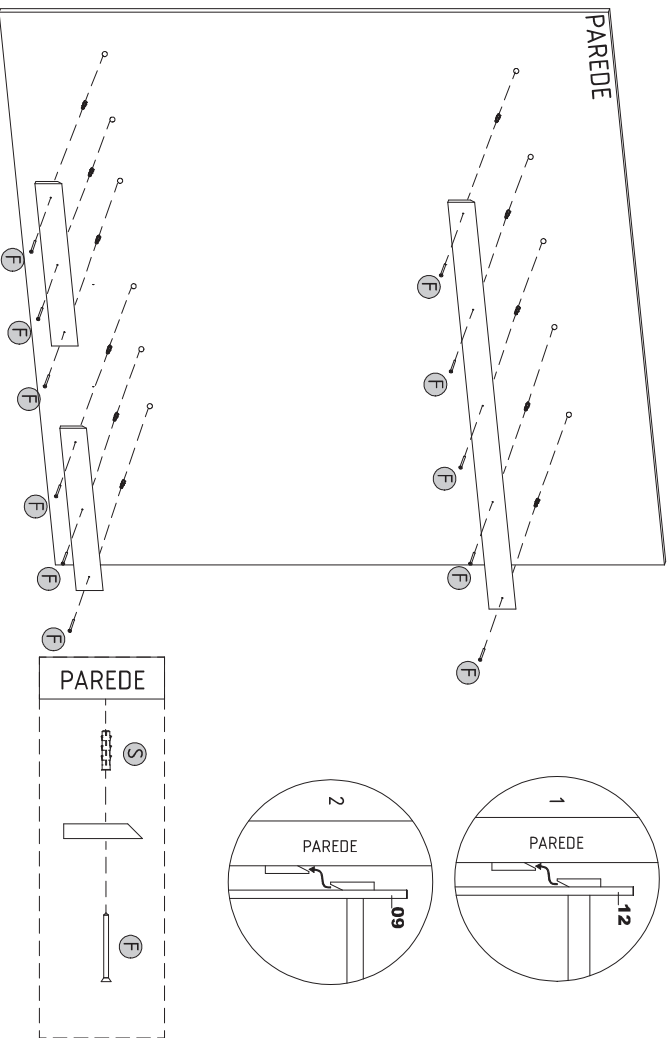

Medida Final

2000mm

1618mm

350mm

**ATENÇÃO:**  
 Fixar TV somente no painel.  
 O painel comporta TV de até 65"