

# INSTRUÇÕES DE MONTAGEM

## Vista de peças

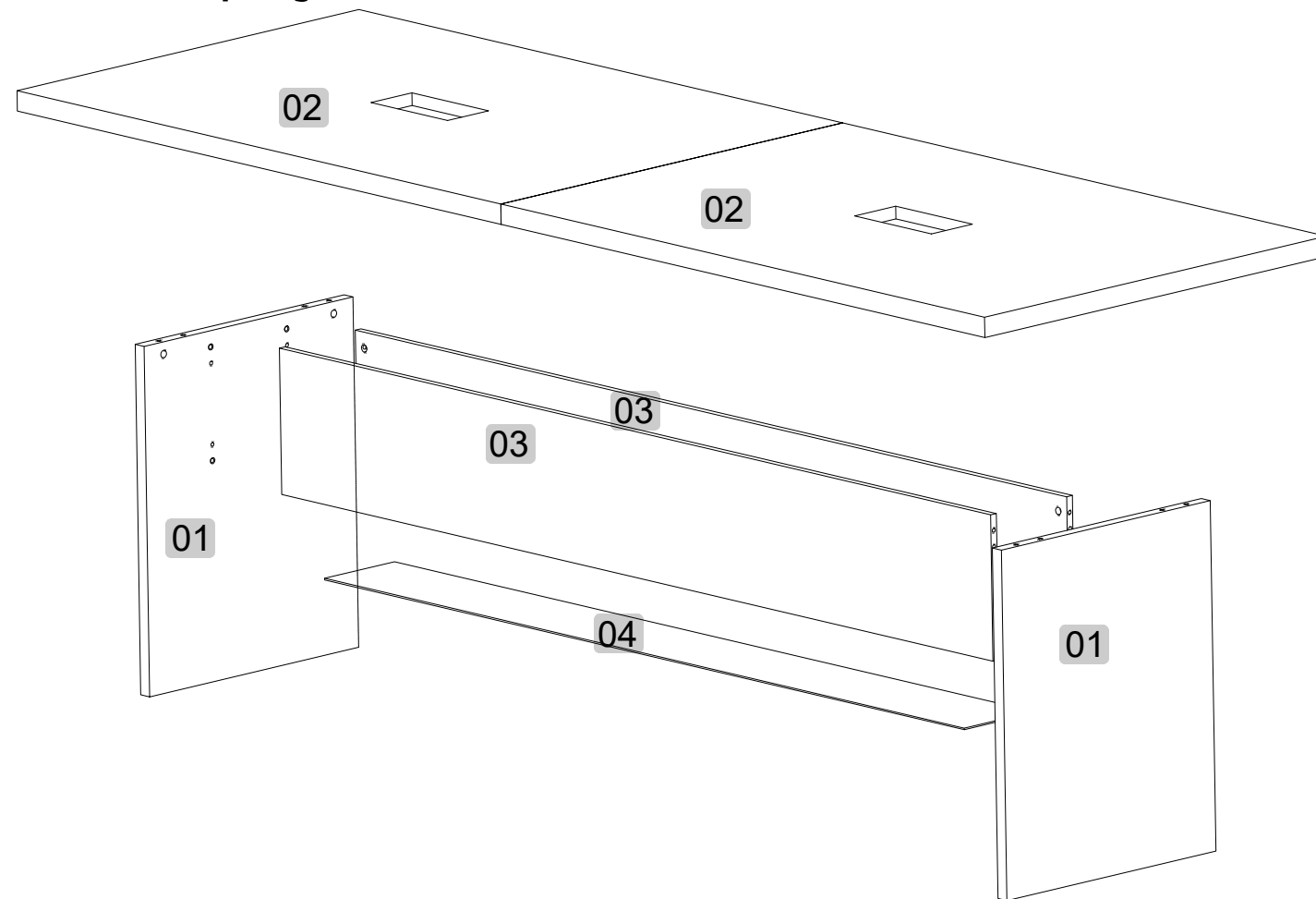

## Produto Montado

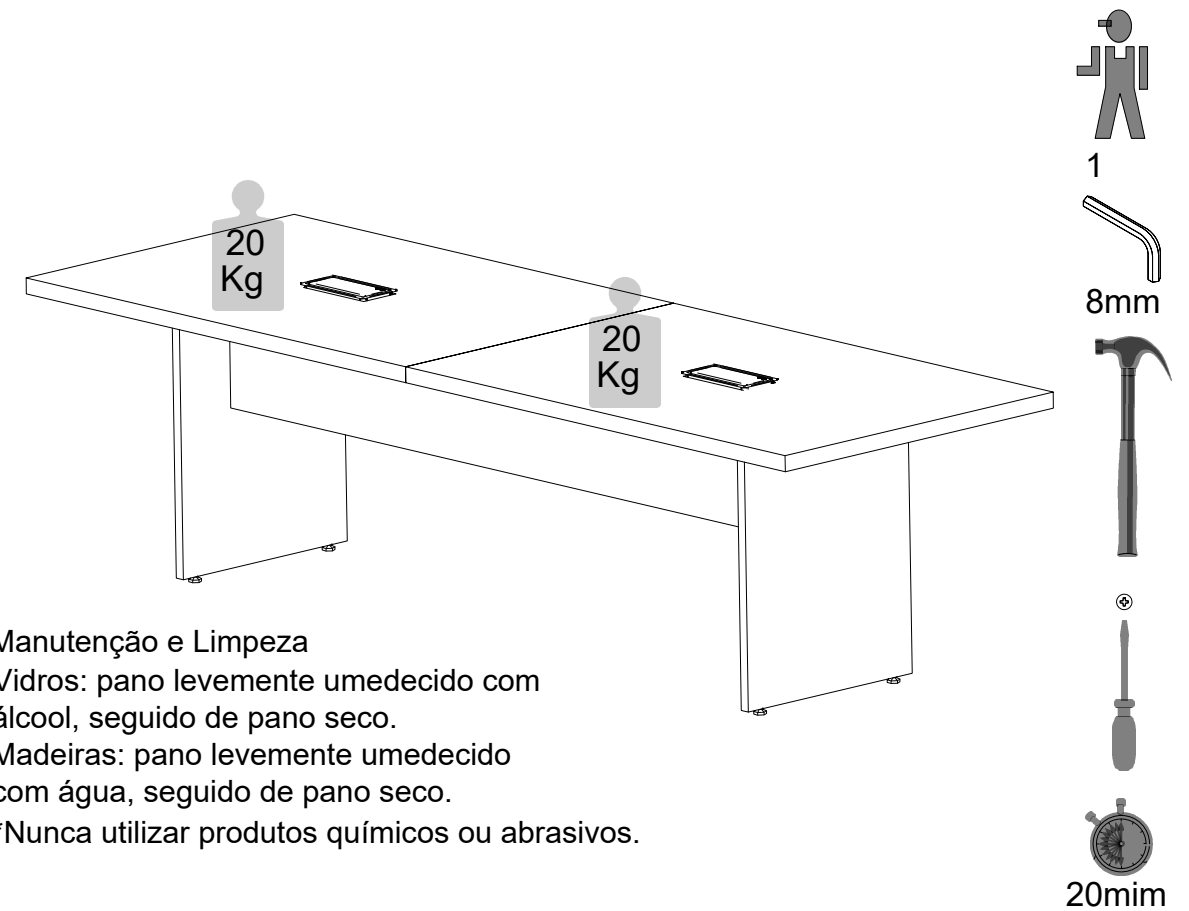

Manutenção e Limpeza  
 Vidros: pano levemente umedecido com álcool, seguido de pano seco.  
 Madeiras: pano levemente umedecido com água, seguido de pano seco.  
 \*Nunca utilizar produtos químicos ou abrasivos.

## Lista de Peças

<b>1</b>	Painel lateral
<b>2</b>	Tampo
<b>3</b>	Painel frontal
<b>4</b>	Travessa

## Acessórios

<b>A8</b>		<b>16</b>	<b>A36</b>		<b>12</b>
		4,0X14 CP			BUCHA M6x33
<b>D1</b>		<b>12</b>	<b>M6</b>		<b>04</b>
		CAVILHA 8x30			CANTONEIRA L
<b>F1</b>		<b>04</b>	<b>L2</b>		<b>04</b>
		TAPA FURO Ø18			SAPATA PLAST. SEXT.
<b>A29</b>		<b>12</b>	<b>L5</b>		<b>04</b>
		MINIFIX M6x33m			BUCHA PLAST. P/ SAPATA 5/16
<b>A35</b>		<b>12</b>	<b>B2</b>		<b>07</b>
		TAMBOR MINIFIX			SUPORTE PRAT. 88x

# INSTRUÇÕES DE MONTAGEM

## 1 Pré-montagem

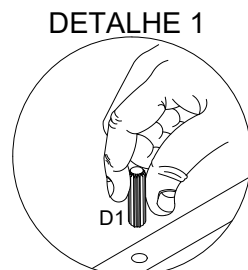
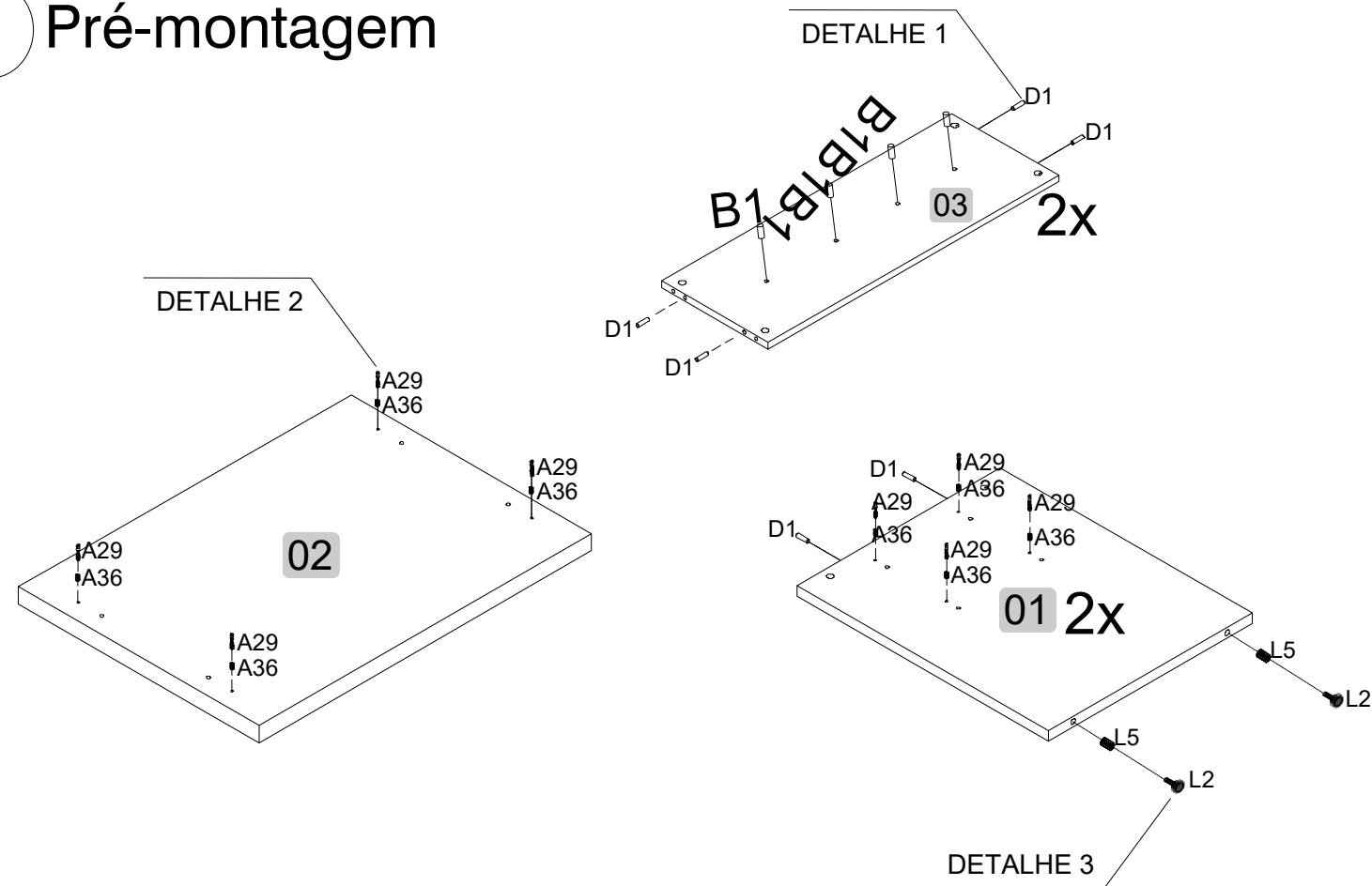

Pressione até o fundo do furo. Se necessário utilize um martelo de borracha.

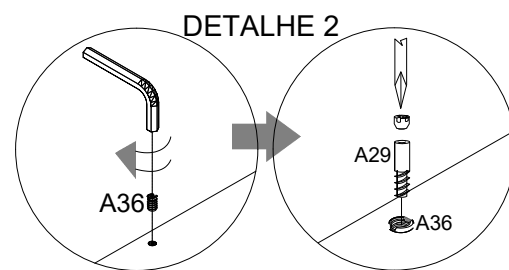

Com uma chave allen insira a bucha na peça, após, rosqueie o parafuso.

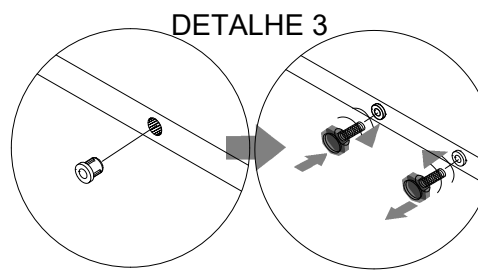

Insira a bucha com um martelo e rosqueie a sapata.

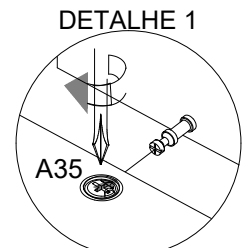
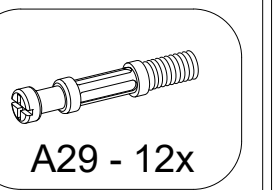
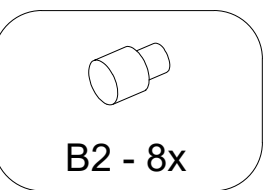
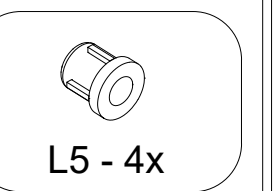
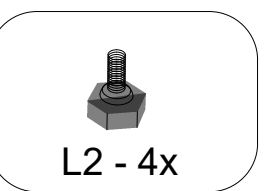
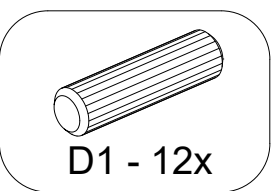
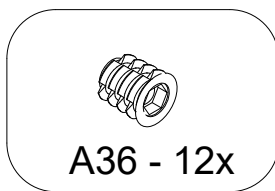

Depois de encaixar as peças coloque o tambor com a sua seta voltada para o parafuso. Para apertar Gire no sentido horário.

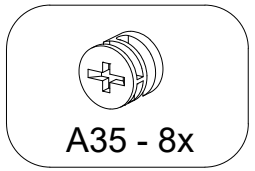

## 2 Montagem

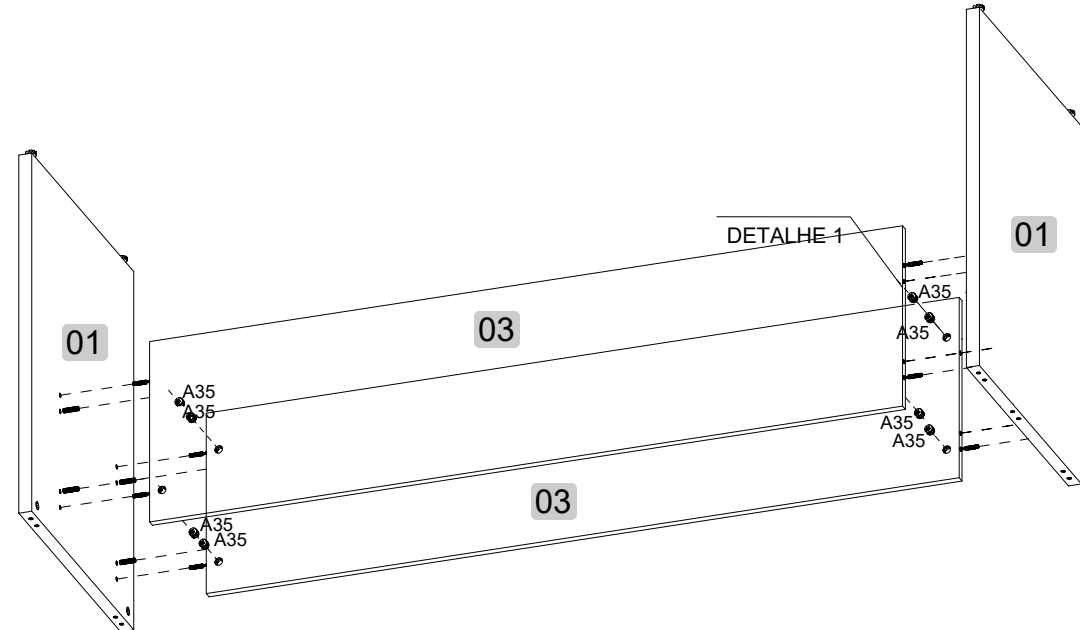

# INSTRUÇÕES DE MONTAGEM

3

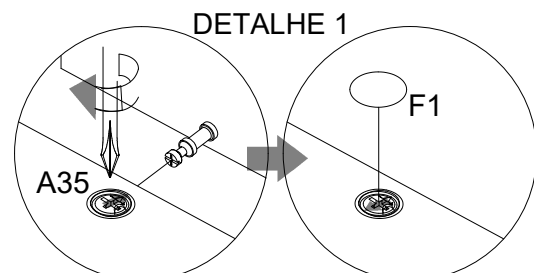
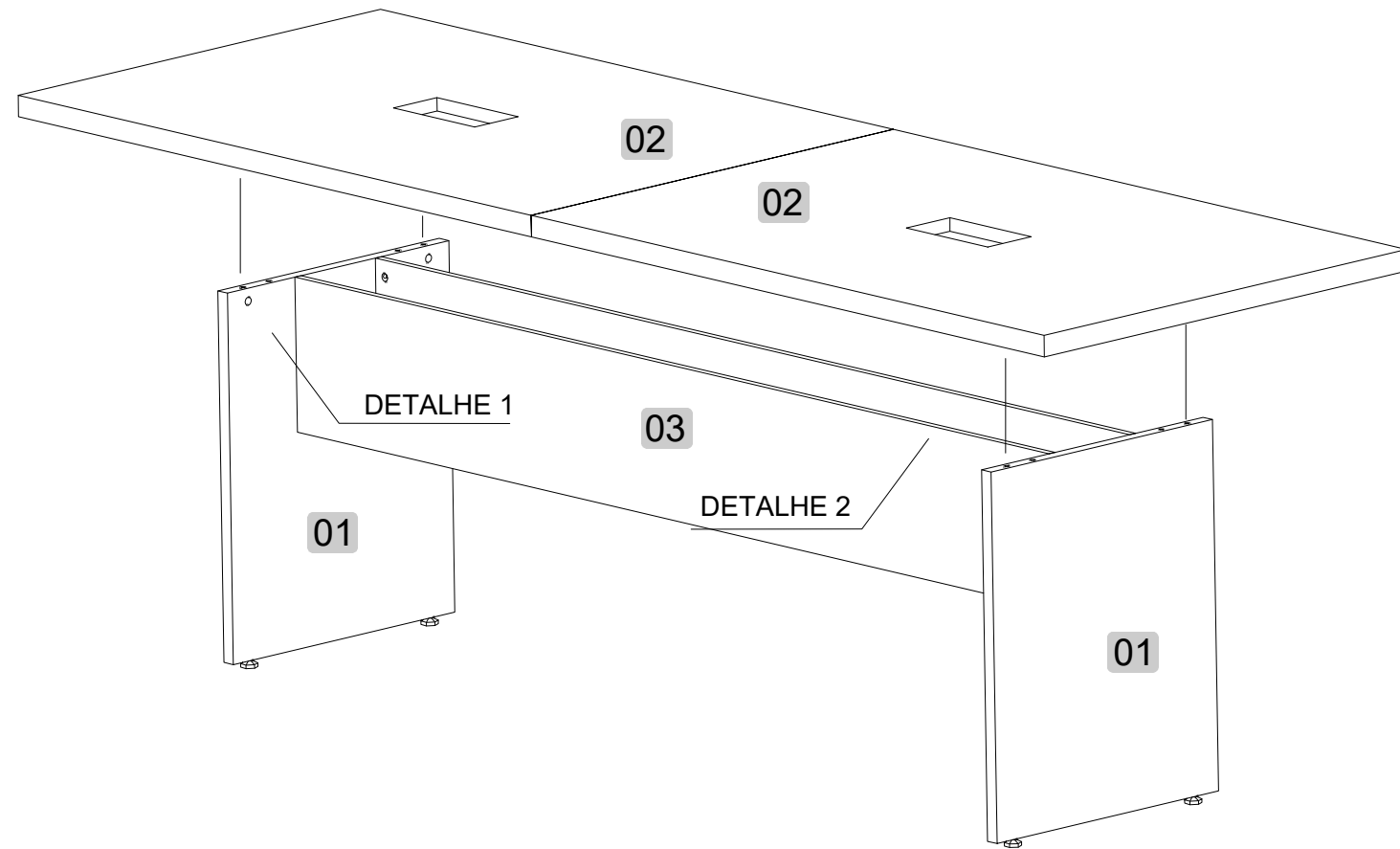

Depois de encaixar as peças coloque o tambor com a sua seta voltada para o parafuso. Para apertar Gire no sentido horário.

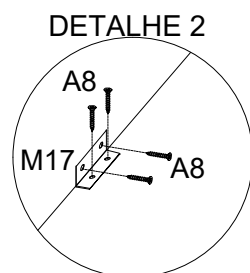

Posicione a cantoneira encostada na quina das peças.

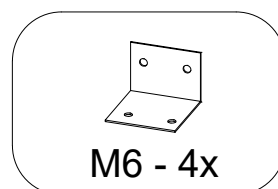
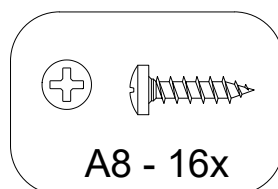
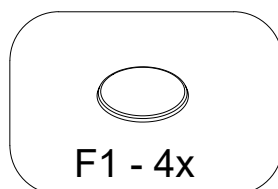
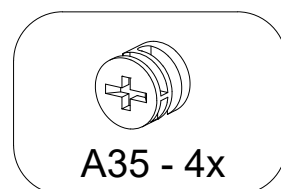

4

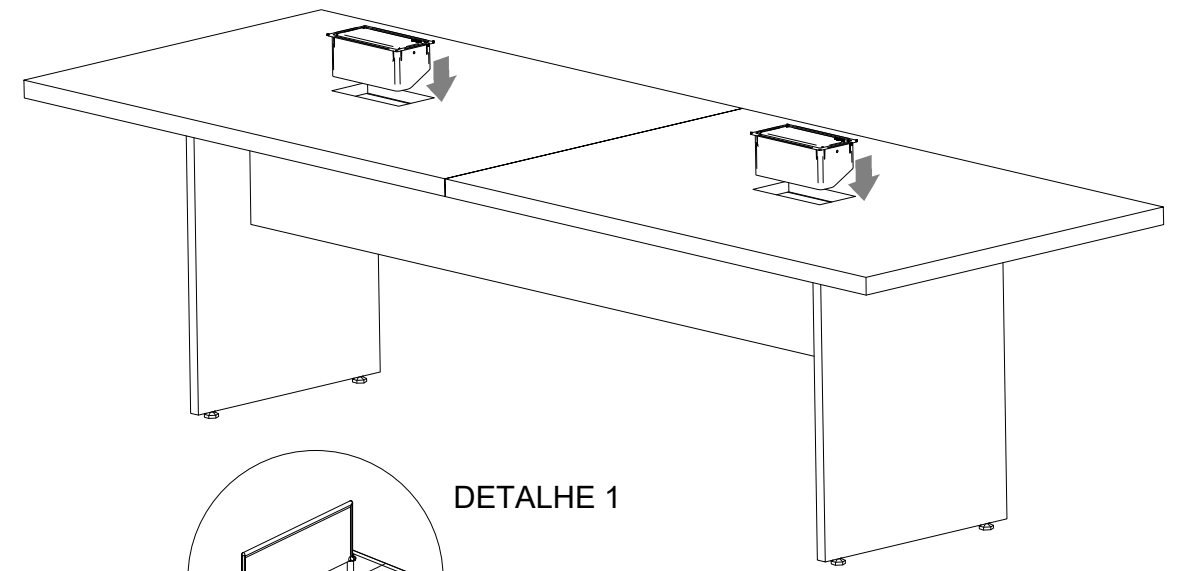
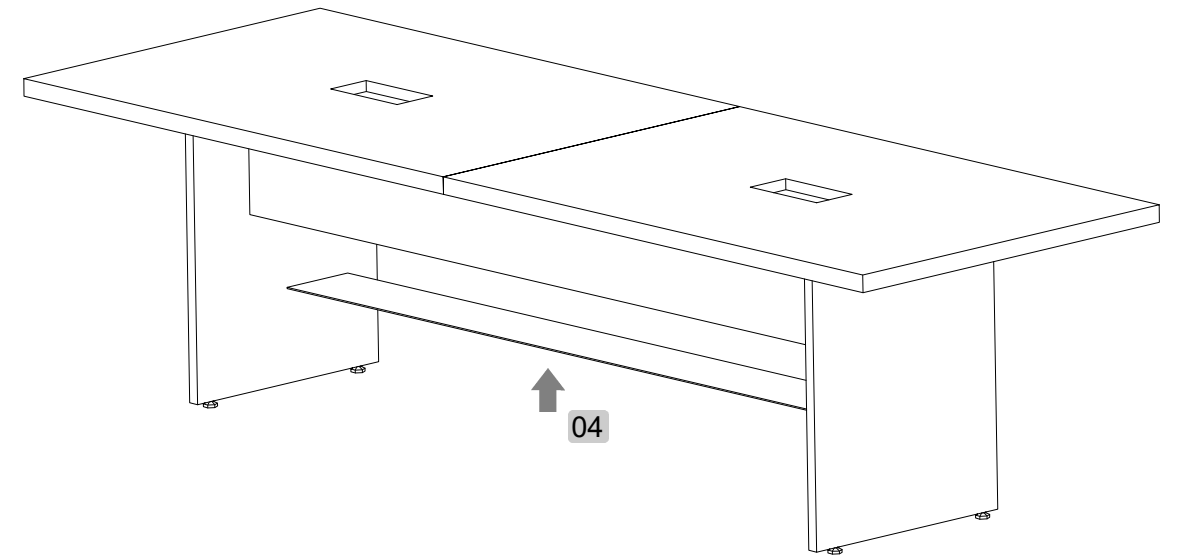

Ver manual de montagem da caixa.