



Para facilitar a fixação do Suporte Universal, enviamos 2 modelos de parafusos que estão de acordo com os padrões mais usados pelos principais fabricantes de TVs LCD / LED / PLASMA / 3D do mercado. Caso nenhum dos 2 modelos se encaixe adequadamente ao seu televisor, adquira o parafuso compatível com sua TV em qualquer loja de ferragens. Para evitar danos à sua TV, não aperte demasiadamente os parafusos.



Atenção

Retirar a TV do painel sempre que:

- Mover o painel
- Manusear os cabos por trás do painel
- Passar novos cabos

- Se a tomada estiver atrás do painel, cuide para que os cabos não fiquem forçando o painel para a frente.

Passos para retirar a TV do painel:

1



Atenção

A TV não sai para os lados devido às travas de segurança do suporte.

VISTA LATERAL

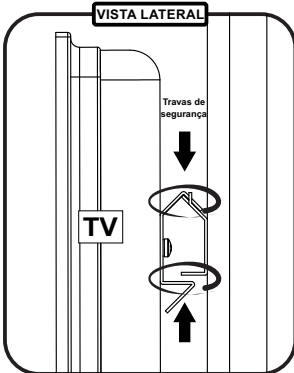

2

Inclinar um pouco a parte de baixo da TV até passar a trava de segurança inferior

VISTA LATERAL

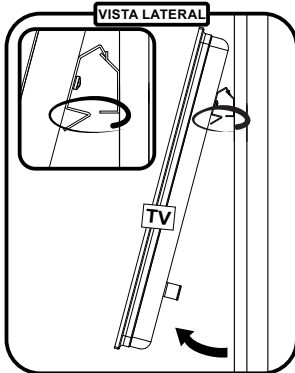

3

Elevar a TV retirando-a totalmente do suporte

VISTA LATERAL

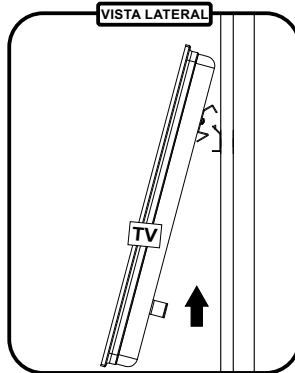

4

Desconectar todos os cabos da TV, retirando-a com segurança

VISTA LATERAL

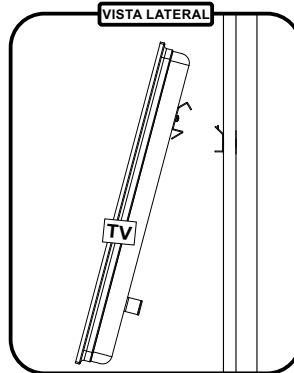

Este painel foi submetido a Testes de Resistência e suporta adequadamente o peso da TV. Não nos responsabilizamos por eventuais danos à TV causados por manuseio inadequado.



-Para una fácil fijación del soporte universal, enviamos 2 de los modelos de tornillos más utilizados en los televisores. Si ninguno encajar en su TV, busque otro en una ferretería. Para evitar daños en su televisor, no apriete demasiado los tornillos.
-To make it easier to attach the TV support, we send 2 screw models that match the most commonly used TVs. If neither model fits your TV properly, purchase the compatible screw from any hardware store. To prevent damage to your TV, do not over tighten the screws.



ATENCIÓN! ATTENTION!

Retire la TV del panel siempre que:

Take out the TV from the panel in the following situations:

- Mover el panel;
- You are moving the wall panel;
- Pasar nuevos cables.
- You are passing new cables.
- Manejar los cables detrás del panel;
- You are handling the cables;

- Si el tomacorriente está detrás del panel, tenga cuidado de que los cables no fuercen el panel adelante.

- If the power plug is behind the panel, be sure that the cables are not forcing the panel forward.

Pasos para retirar la televisión del panel: Steps to remove the TV from the wall panel:

1

-La TV no sale para los lados, debido a las travas de seguridad del soporte;

-There are safety locks in the support that keep the TV in its place. You can not take out the TV moving it to the sides.

VISTA LATERAL
SIDE VIEW

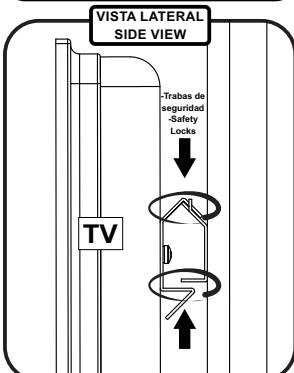

2

-Incline la parte inferior del televisor ligeramente hasta que pase la trava de seguridad inferior;

- Incline the bottom of the TV so that it passes the lower safety lock.

VISTA LATERAL
SIDE VIEW

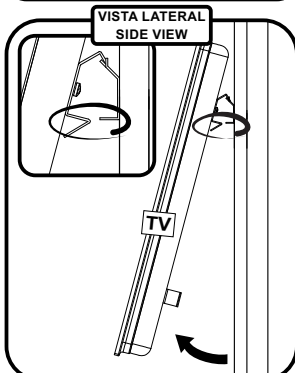

3

-Levante el televisor quitándolo completamente del soporte;

-Lift the TV, removing it completely from the support.

VISTA LATERAL
SIDE VIEW

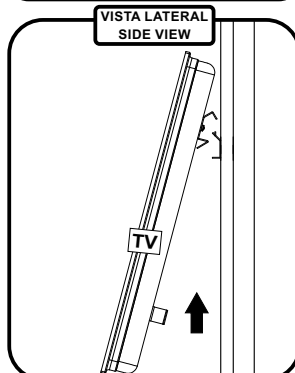

4

-Desconecte todos los cables de la TV, quitándola con seguridad.

-Disconnect all the TV cables and remove the TV safely.

VISTA LATERAL
SIDE VIEW

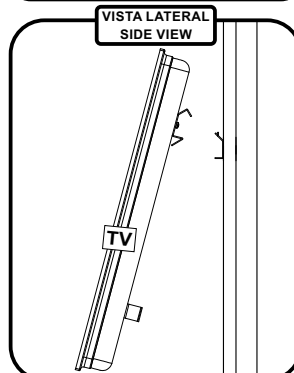

-Ese panel fue sometido a Pruebas de Resistencia y soporta adecuadamente el peso del televisor. No somos responsables de ningún daño al televisor causado por manejo inadecuado.

-This panel has undergone resistance tests and adequately supports the weight of the TV. We are not responsible for TV damage caused by inappropriate handling.

-Esse produto foi projetado para colocar a TV no painel, não no nicho.

-Este producto fue diseñado para colocar el televisor en el panel, no en el nicho.

-This product is designed to put the TV on the panel not on the niche.

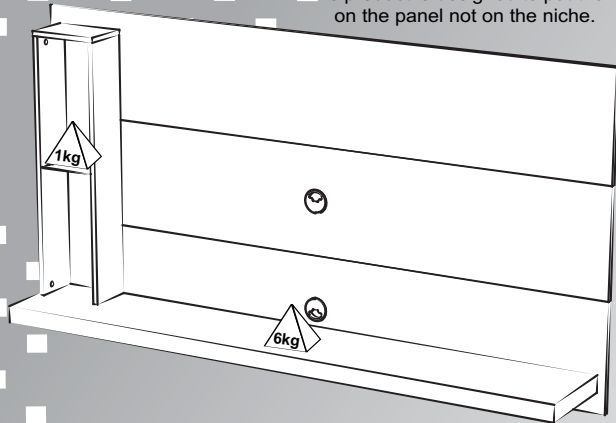

Painel Alaska

Painel Alaska / Alaska Pane

Versão 1.0 / Versión 1.0 / Version 1.0

Assista ao vídeo com dicas de montagem em nosso site: www.artely.com.br

MANUAL DO PRODUTO

Manual del Producto
User's Guide

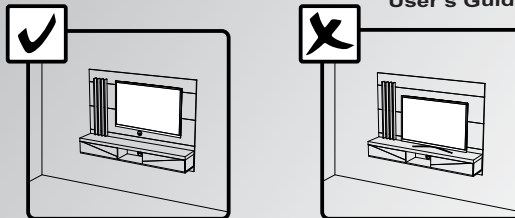

1800mm

310mm

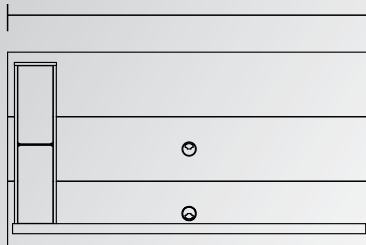

frente/frente/front

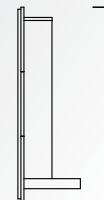

lateral/lado/side

960mm



Conservação e Limpeza

Conservación y Limpieza
Conservation and Cleaning

Não expor o produto ao sol, altas temperaturas e umidade. Não arrastar objetos sobre a superfície do móvel (ex.: TV, DVD, aparelho de som, objetos decorativos...) e manter em local seco e arejado. Para a limpeza, utilizar um pano seco e macio. Não é necessário o uso de materiais abrasivos ou álcool.











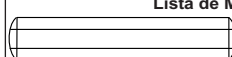

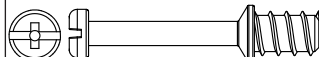
No exponga el producto a la luz solar, las altas temperaturas y la humedad. No arrastre los objetos a través de la superficie de la unidad (por ejemplo, TV, DVD, equipo de música, objetos de decoración ...) Mantener en un lugar fresco y seco.

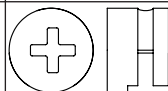
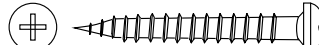
Para la limpieza, utilizar un paño seco y suave. El uso de materiales abrasivos o del alcohol no es necesario.

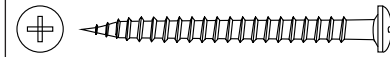
Do not expose the product to sunlight, high temperatures and humidity. Do not drag objects across the surface of the unit (TV, DVD, stereo, decorative objects ...) keep it in a cool dry place. For cleaning, use a dry and soft cloth. Do not use abrasive materials or alcohol.

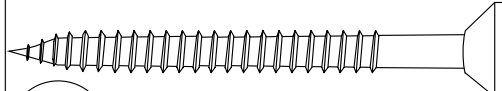
Lista de Materiais

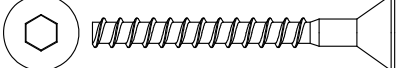
Lista de Materiales/ Hardware List

A		Cavilha / Tarugo / Dowel	06	H		Parafuso / Tornillo / Screw Ø4,0x20mm CP	28
B		Minifix / Minifix / Minifix	04	I		Passa Fio / Pasacables / Cable Hole Cover	02
C		Tambor / Tambor / Minifix Cam	04	J		Parafuso / Tornillo / Screw Ø4,0x30mm CP	04
D		Tapa furo adesivo / Adhesivo / Hole Cover	04	K		Parafuso / Tornillo / Screw Ø4,0x14mm CP	08
E		Parafuso Tornillo / Screw Ø3,5x40mm CP	03	L		Chapa Reta / Placa Recta / Mending Plate 50x13mm	04
F		Parafuso / Tornillo / Screw 5,5x65mm Cab 13	08	M		Fita dupla face Cinta doble face / Double face tape	10
G		Bucha / Casquillo / Bushing	08	N		Parafuso Tornillo / Screw Ø5x40mm cab 10	04
				O		Chave Zeta Clave Zeta / Allen Key	01
				P		Suporte Dot para vidro 3mm	04

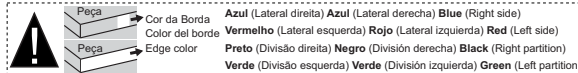
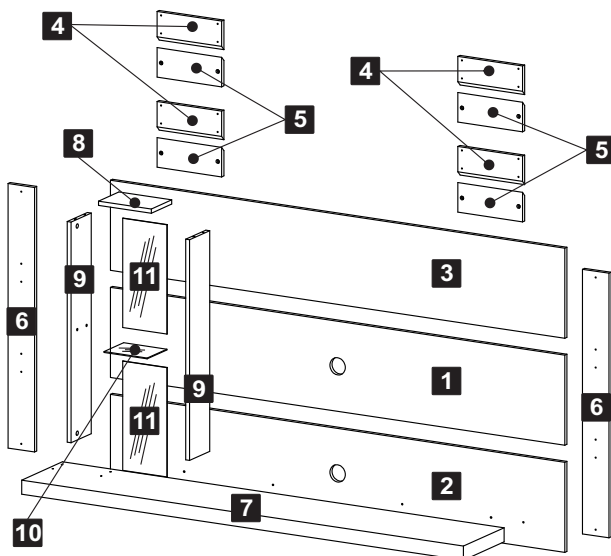

Denominação

- 1-Painel central (1800X320X15mm)
- 2-Painel inferior (1800X320X15mm)
- 3-Painel superior (1800X320X15mm)
- 4-Travessa menor (256X105X15mm)
- 5- Travessa parede(256X105X15mm)
- 6-Travessa maior (940X105X15mm)
- 7-Prateleira (1750X280X50mm)
- 8-Tampo nicho (209X140X15mm)
- 9-Lateral nicho (784X139X15mm)
- 10-Prateleira vidro (171X135X3mm)
- 11-Espelho (388X175X3mm)

Denominación

- 1-Panel central
- 2-Panel inferior
- 3- Panel superior
- 4-Travesaño menor
- 5-Travesaño pared
- 6-Travesaño mayor
- 7-Anaque
- 8-Tapa nicho
- 9-Lateral nicho
- 10-Anaque vidro
- 11-Espejo

Description

- 1-Center panel
- 2-Lower panel
- 3-Upper panel
- 4-Small crosspiece
- 5-Wall crosspiece
- 6-Bigger crosspiece
- 7-Shelf
- 8-Niche top
- 9-Niche side
- 10-Glass shelf
- 11-Mirror

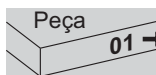

- O número na borda da peça corresponde ao manual.
- Para retirada do número usar Lustra-Móveis ou Alcool em Gel.
-El número en el borde de la pieza coincide con el manual.
-Use alcohol en gel o lustrador para muebles para eliminar los números.
-The number on the edge of the piece matches the manual.
-Use Alcohol Gel or Furniture Polish to remove the numbers.

1 Passo
Paso
Step

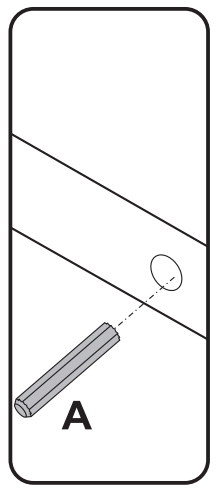
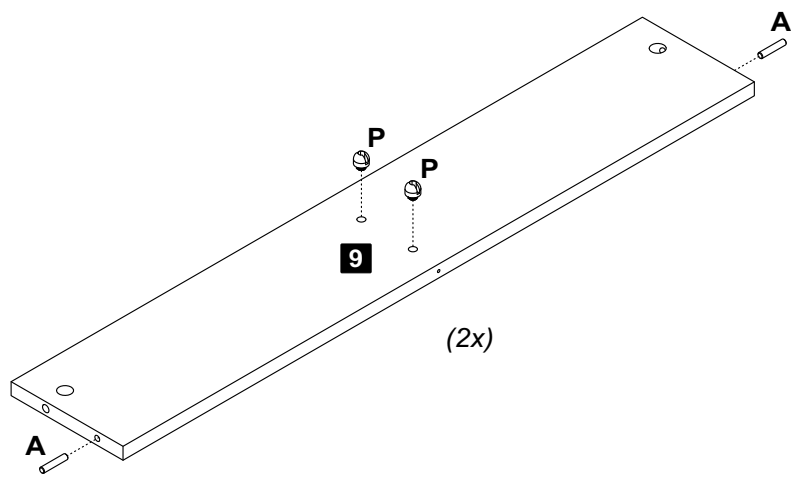

- A** Cavilha **04**
- P** Suporte Dot para vidro 3mm **04**

2 Passo
Paso
Step

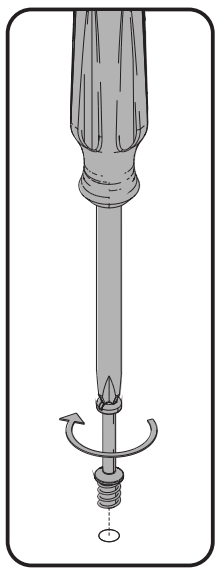
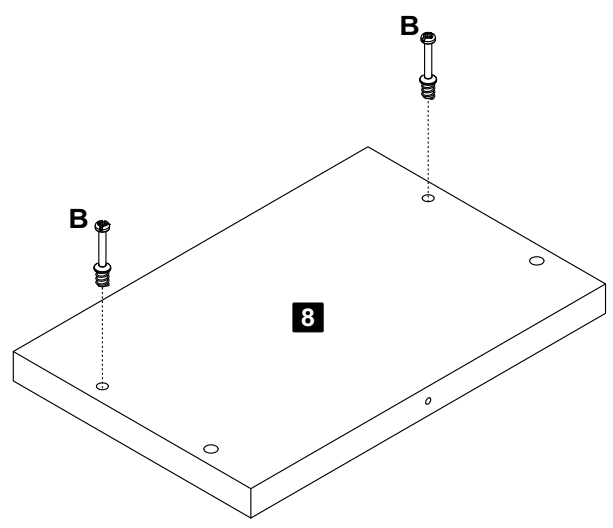

- B** Minifix **02**

3 Passo
Paso
Step

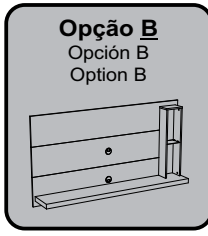
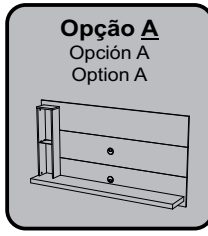

Obs: -Escolha entre a Opção A ou Opção B, após a fixação dos parafusos não é possível mudar de opção.
 Nota: Elija entre la opción A o B. Después de fijar los tornillos, no es posible cambiar la opción.
 Note: Choose between Option A or B. After fixing the screws it is not possible to change the option.

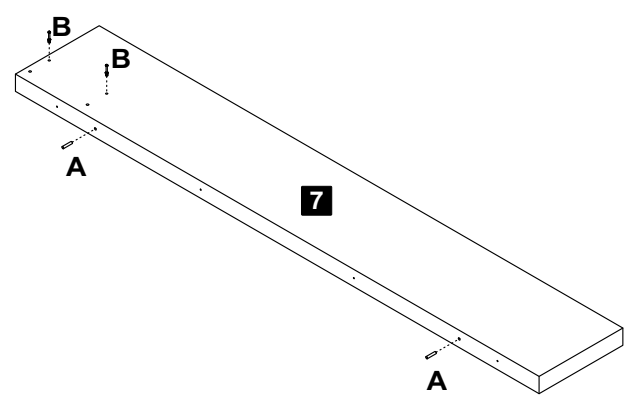
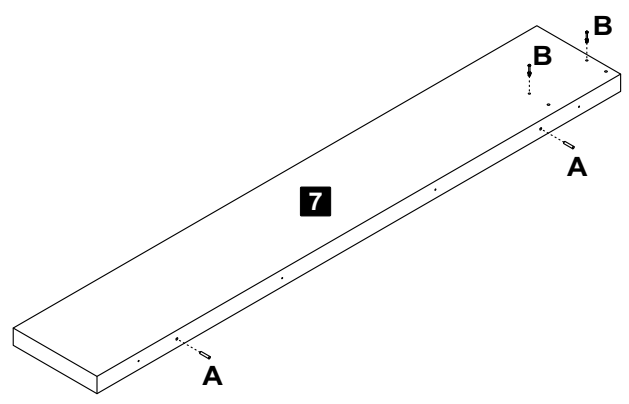

- A** Cavilha **02**
- B** Minifix **02**

4 Passo
Paso
Step

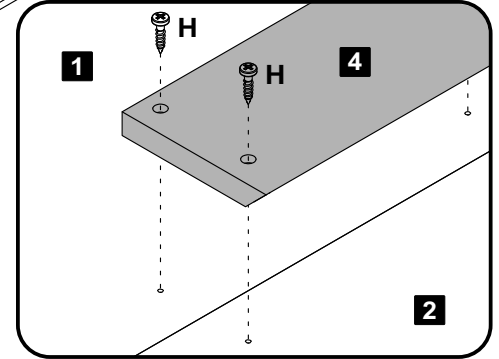
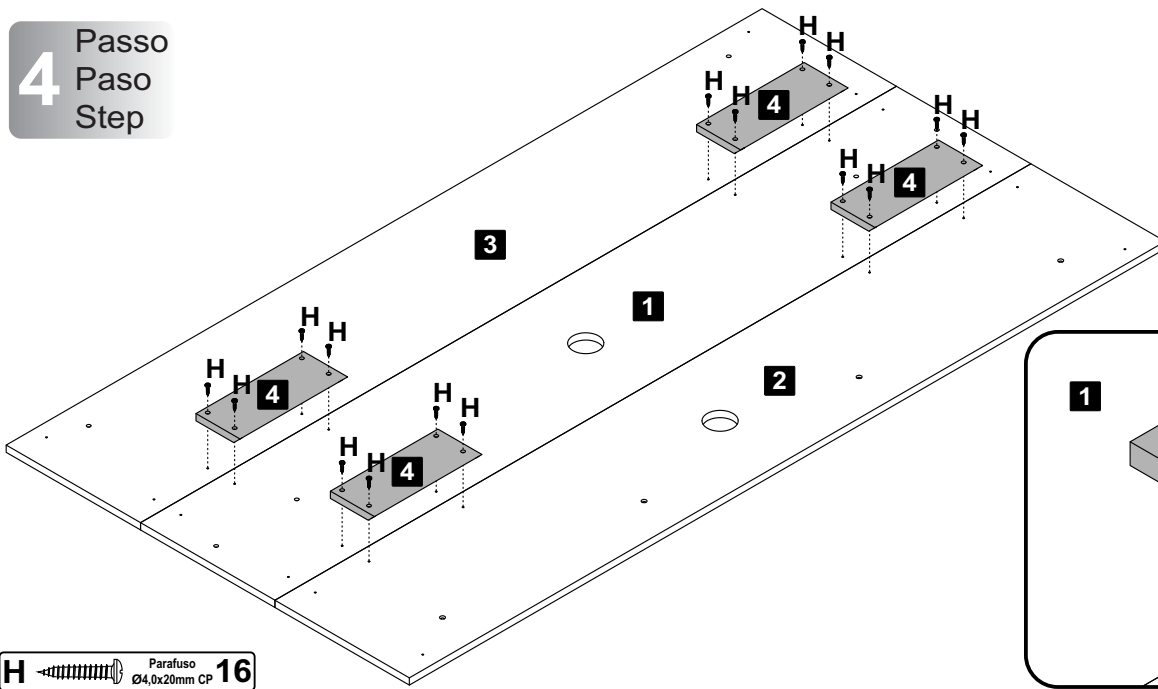

H Parafuso Ø4,0x20mm CP **16**

5 Passo
Paso
Step

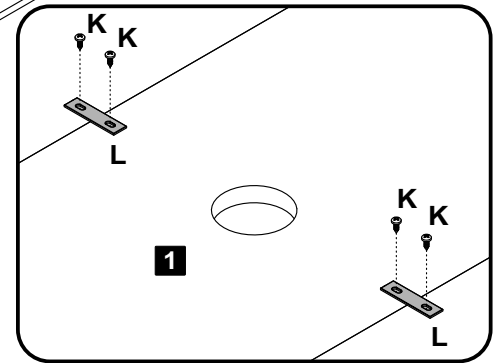
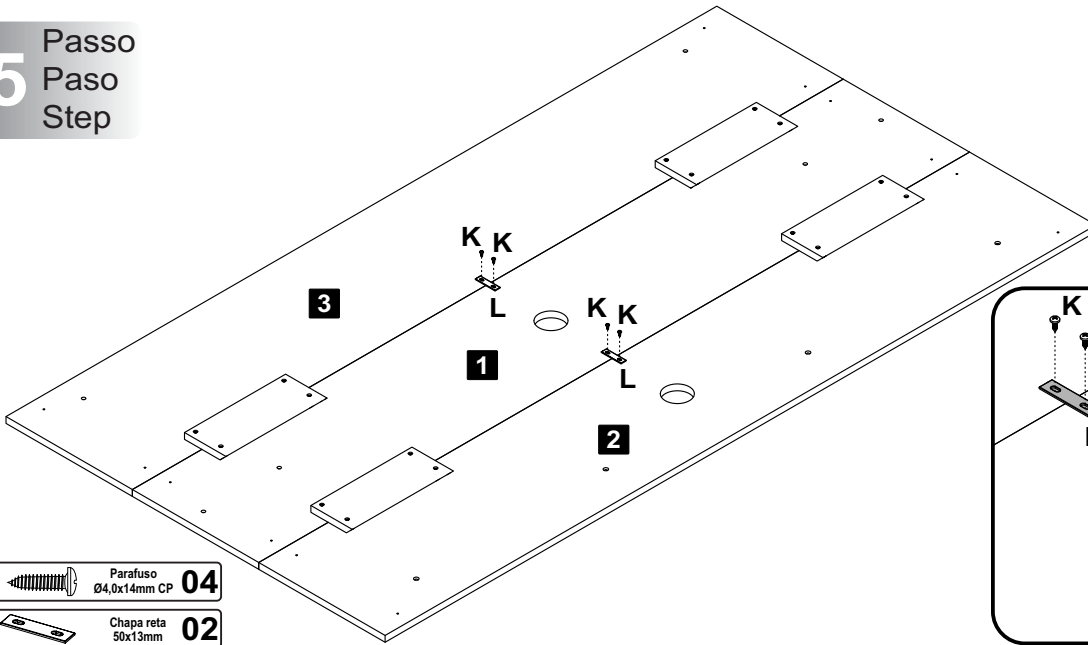

K Parafuso Ø4,0x14mm CP **04**

L Chapa reta 50x13mm **02**

6 Passo
Paso
Step

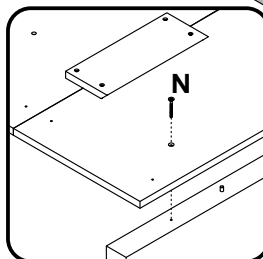
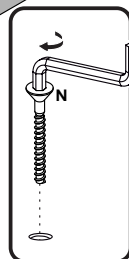
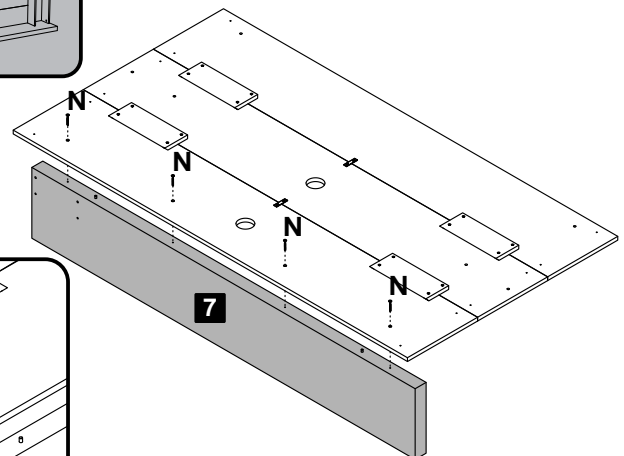
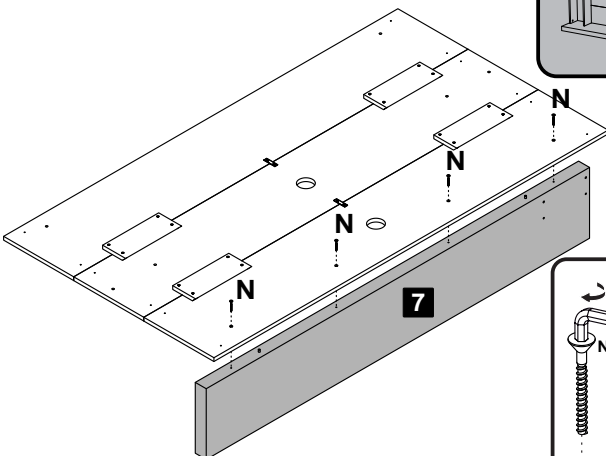
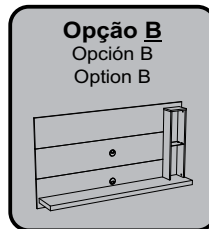
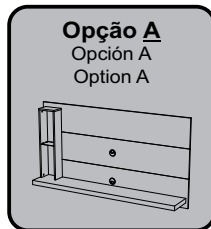

N Parafuso Ø5,0x40mm **04**

7 Passo
Paso
Step

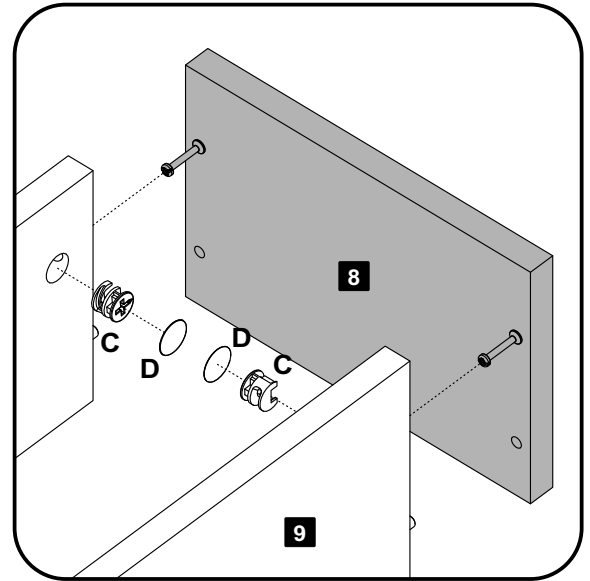
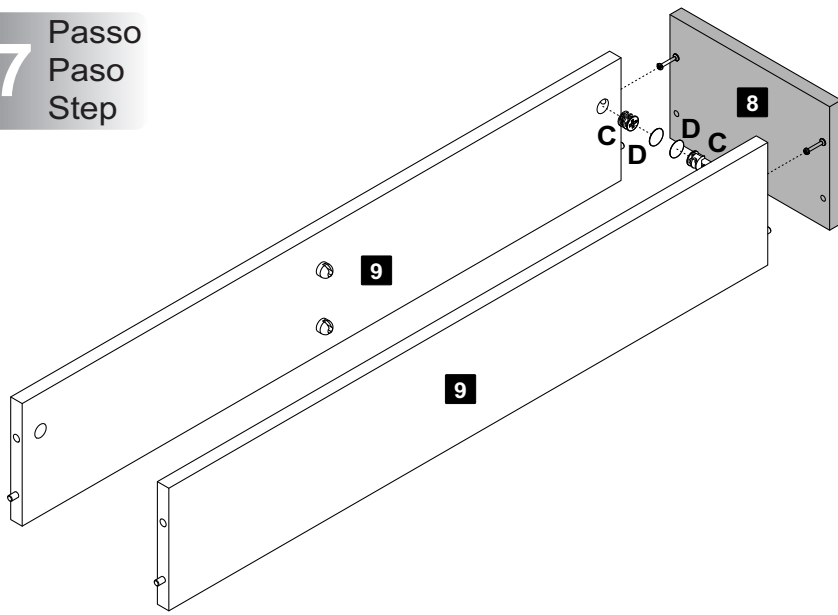

C  Tambor **02** **D**  Tapa Furo Adesivo **02**

8 Passo
Paso
Step

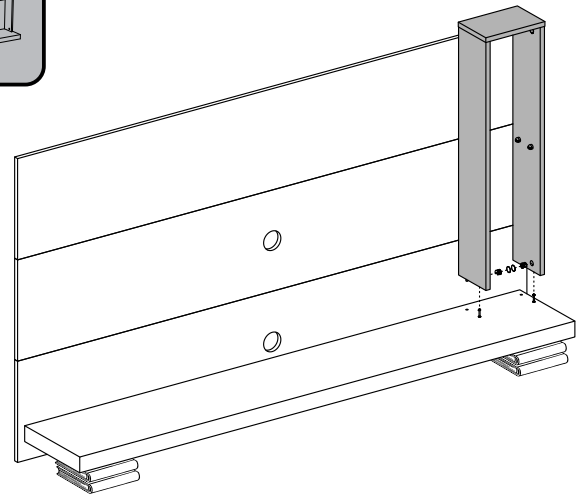
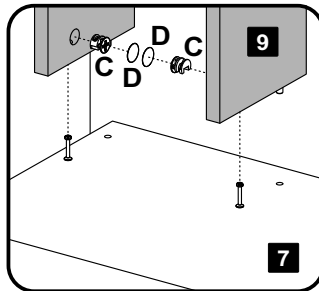
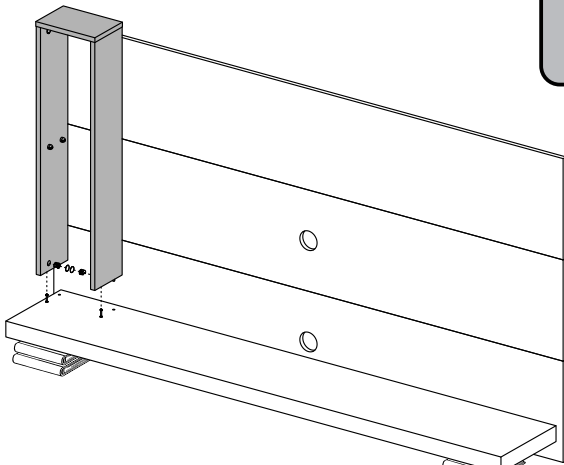
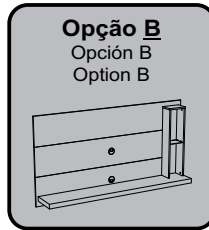
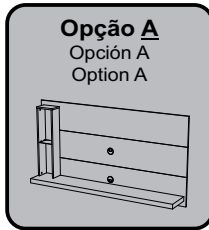

C  Tambor **02** **D**  Tapa Furo Adesivo **02**

9 Passo
Paso
Step

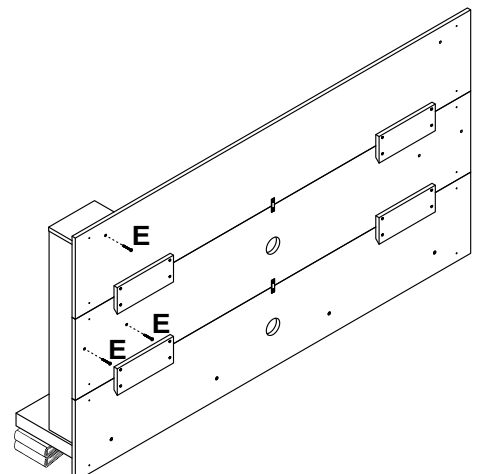
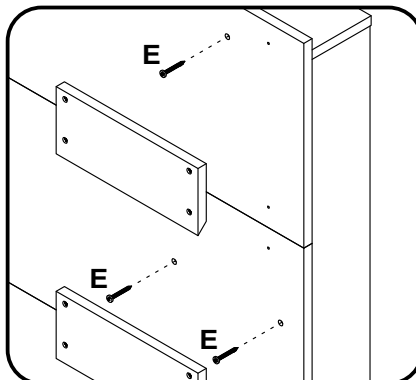
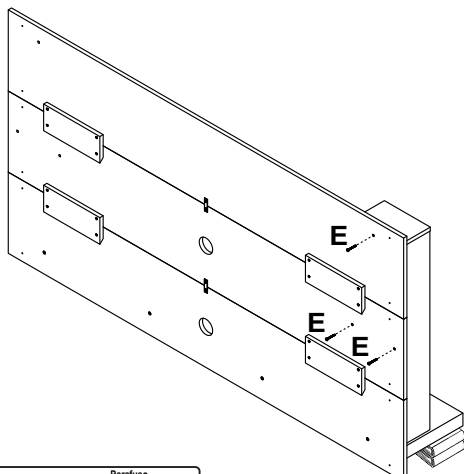
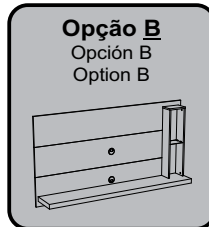
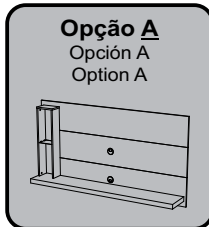

E  Parafuso Ø3,5x40mm CP **03**

10 Passo
Paso
Step

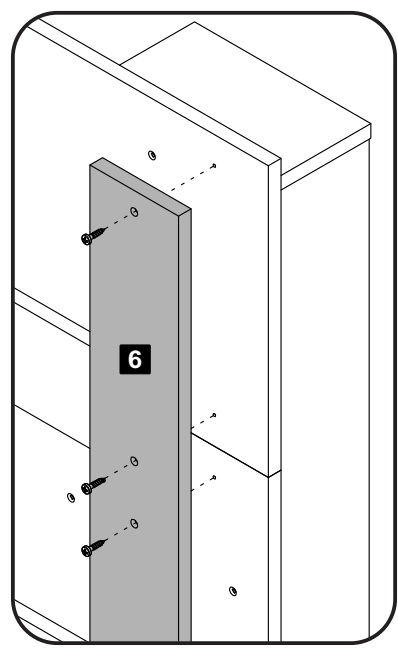
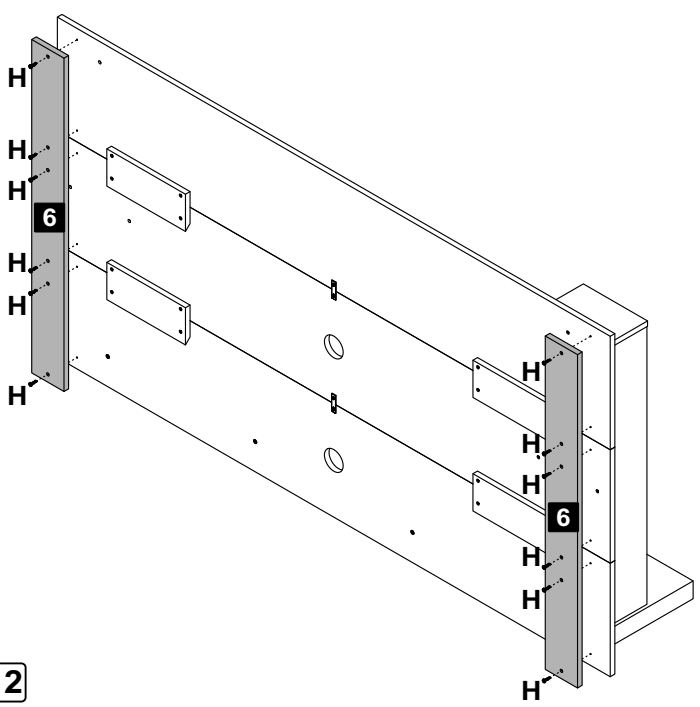

H Parafuso Ø4,0x20mm CP **12**

11 Passo
Paso
Step

Esquema de furação da parede / Esquema de perforación de la pared / Wall drilling Scheme

Fixar o gabarito na parede com fita.

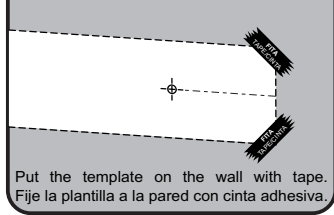

Furar a parede conforme o gabarito.

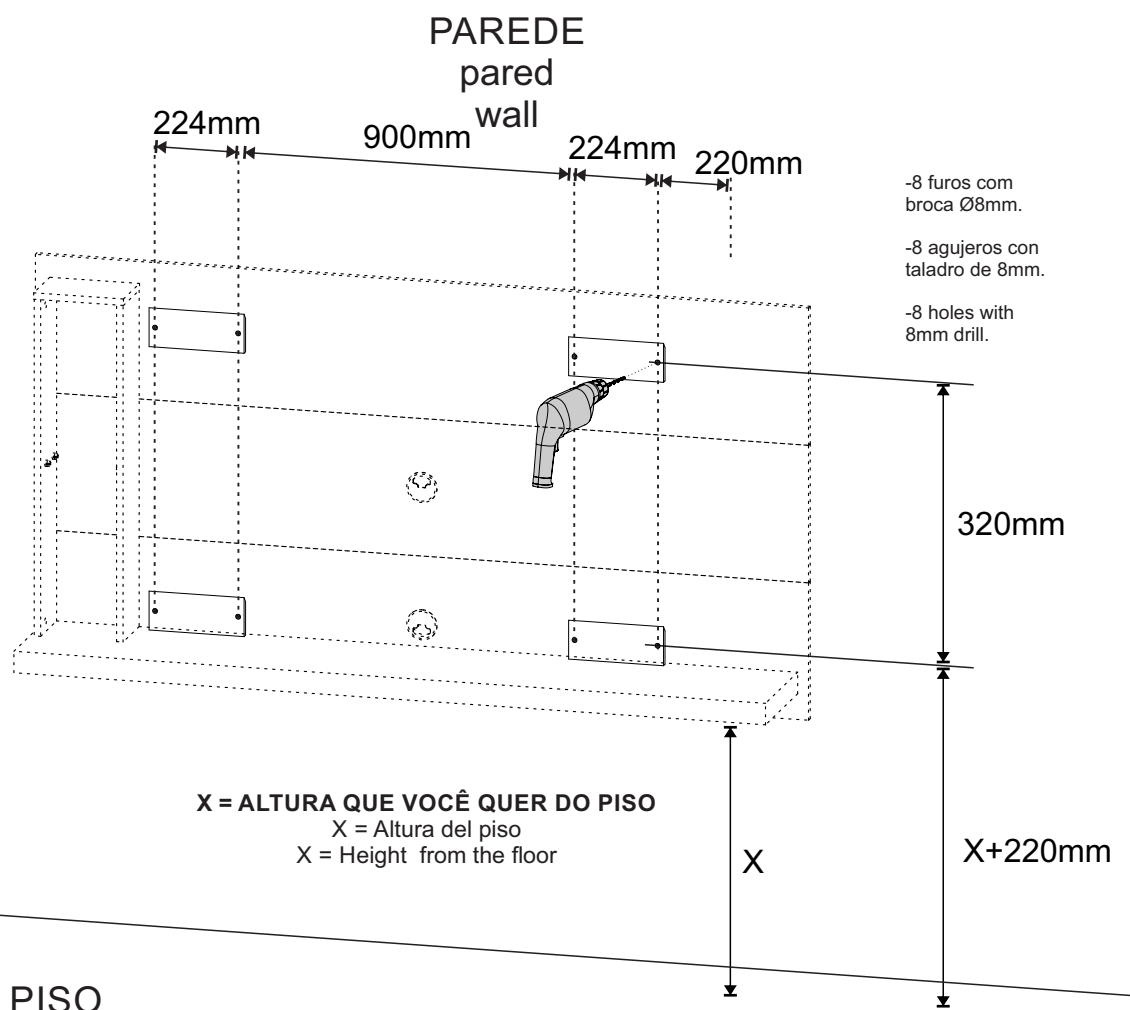
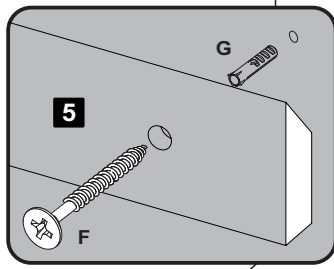
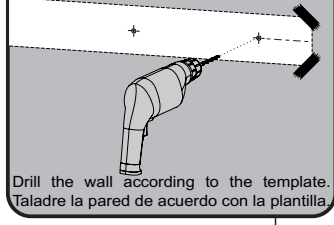

**Obs: -Nivelar as travessas na parede.
-Nivelar los travesaños en la pared.
-Level the crosspieces on the wall.**

F Parafuso 5,5x50mm Cab 13 **08** **G** Bucha Ø8mm **08**

Ex: Se você quer que o painel fique a 800mm do piso:
Altura do primeiro furo = 800+285=1085mm
Altura do segundo furo = 1085+764=1849mm

Ejemplo:
Si desea que el panel esté a 800 mm del piso:
Altura del primer agujero= 800+285=1085mm
Altura del segundo agujero= 1085+764=1849mm

Example:
If you want the panel to be 800mm from the floor:
Height of the first hole line = 800+285=1085mm
Height of second hole line = 1085+764=1849mm

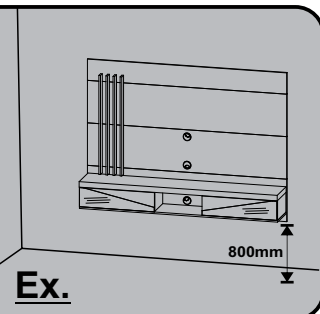

12 Passo
Paso
Step

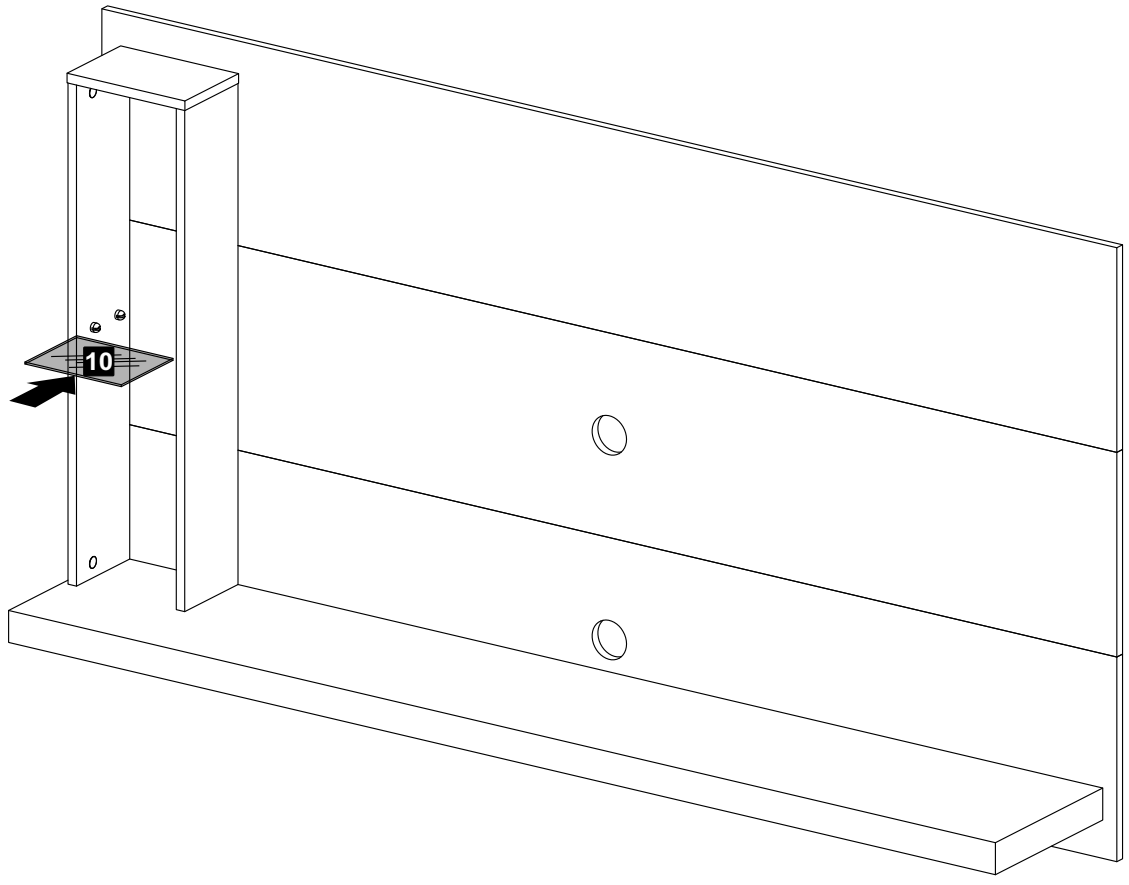

13 Passo
Paso
Step

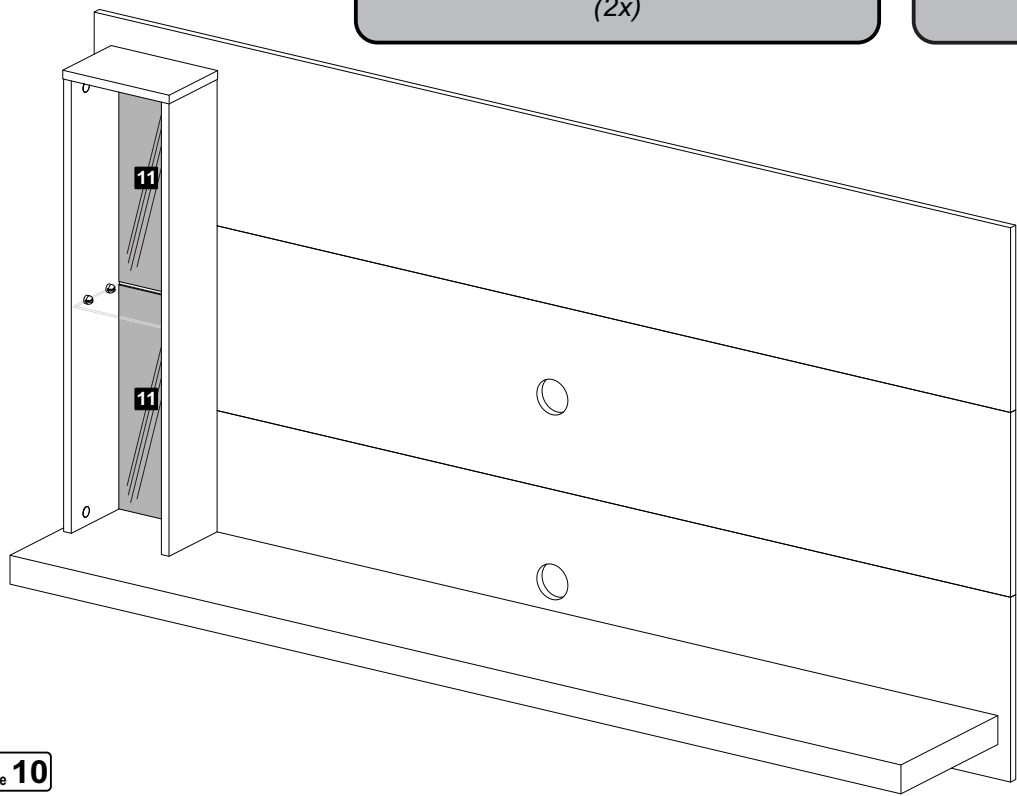
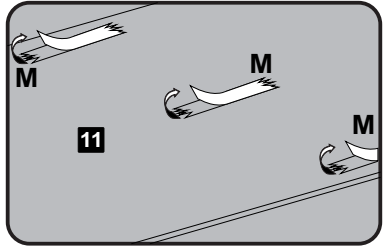
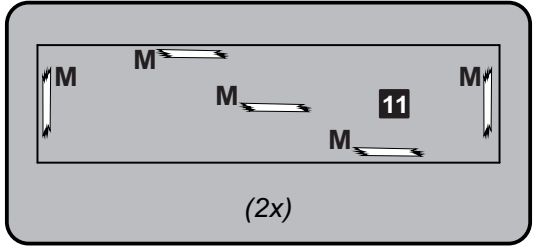



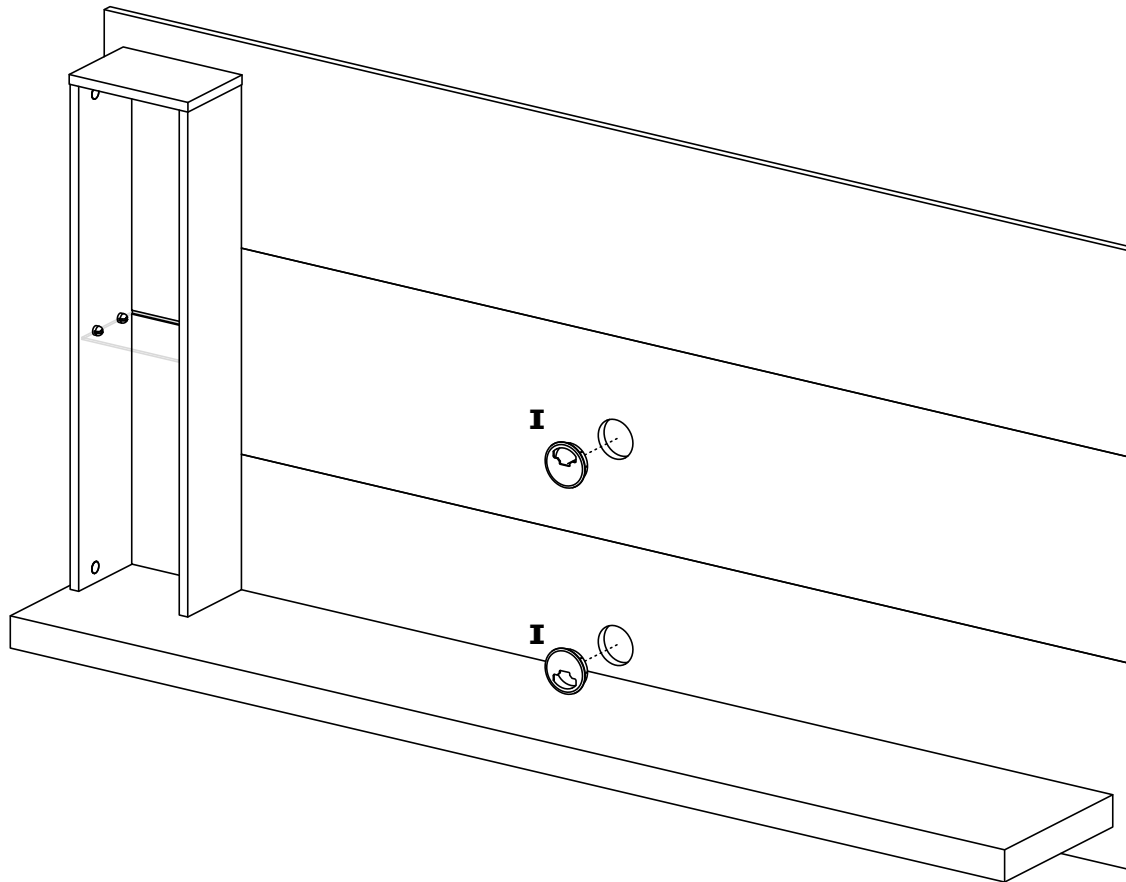

14 Passo
Paso
Step



I  Passa Fio Ø60mm **02**

15 Passo
Paso
Step

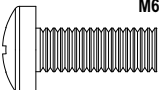
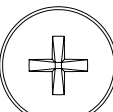
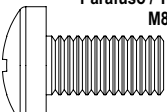
kit suporte TV kit soporte para TV / TV support kit				
R	 R1 35x77mm	 R2 48x28mm	 R3 100x56mm	02
R6			Parafuso / Tornillo / Screw M6 x 16	04
R7			Parafuso / Tornillo / Screw M8 x 16	04

-Para facilitar a fixação do Suporte Universal, enviamos 2 modelos de parafusos que estão de acordo com os padrões mais usados pelos principais fabricantes de TVs LCD / LED / PLASMA / 3D do mercado. Caso nenhum dos 2 modelos se encaixe adequadamente ao seu televisor, adquira o parafuso compatível com sua TV em qualquer loja de ferragens. Para evitar danos à sua TV, não aperte demasiadamente os parafusos.



-Para facilitar la colocación del soporte universal, enviamos 2 modelos de tornillos que cumplen con los estándares más utilizados por los principales fabricantes de televisores. Si ninguno de los modelos se ajusta a su televisor correctamente, compre el tornillo compatible con su televisor en cualquier ferretería. Para evitar daños a su televisor, no apriete demasiado los tornillos.

-To make it easier to attach the TV support, we send 2 screw models that match the most commonly used TVs. If neither model fits your TV properly, purchase the compatible screw from any hardware store. To prevent damage to your TV, do not over tighten the screws.

16 Passo
Paso
Step

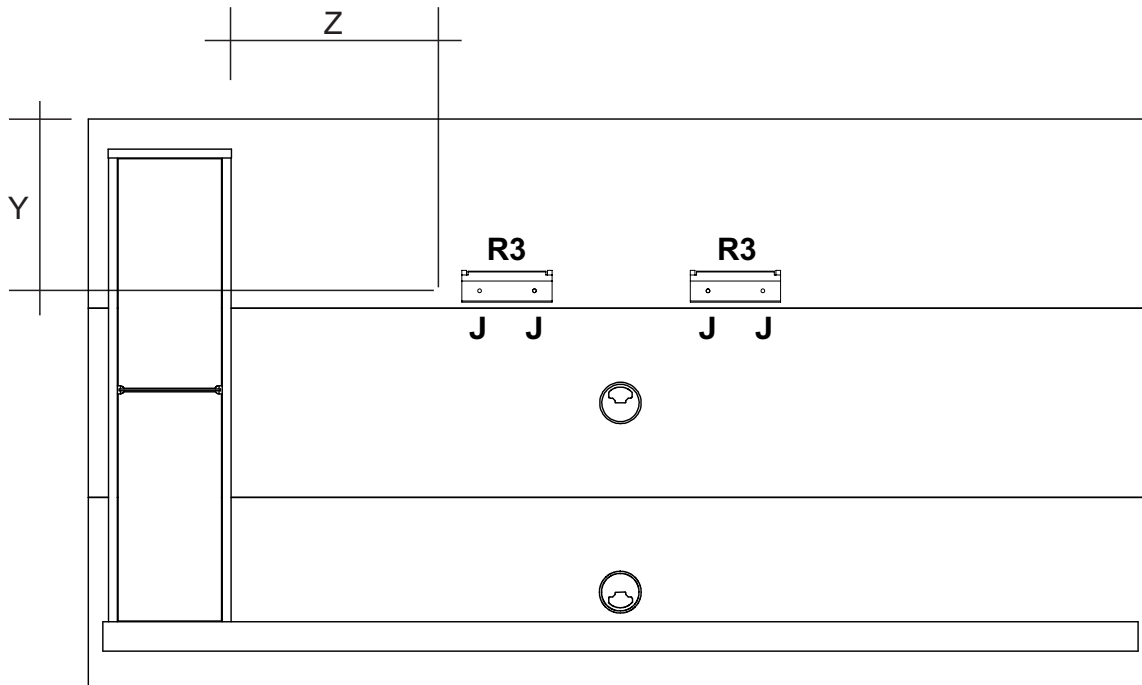

Utilizar a Norma VESA do manual da TV, para calcular a centralização e altura da TV no painel.

Use el estándar VESA del manual del televisor para calcular el centrado y la altura del televisor en el panel.

Use the VESA Standard from the TV manual to calculate the centering and height of the TV on the panel.

- J** Parafuso Ø4,0x30mm CP **04**
- R3** Kit Suporte TV **02**

17 Passo
Paso
Step

Suporte Superior

Suporte superior / Upper support

Utilizar o parafuso indicado no manual da TV R6 / R7(VESA).

Use el tornillo indicado en lo manual del televisor R6 / R7(VESA).

Use the screw indicated in the TV manual R6 / R7(VESA).

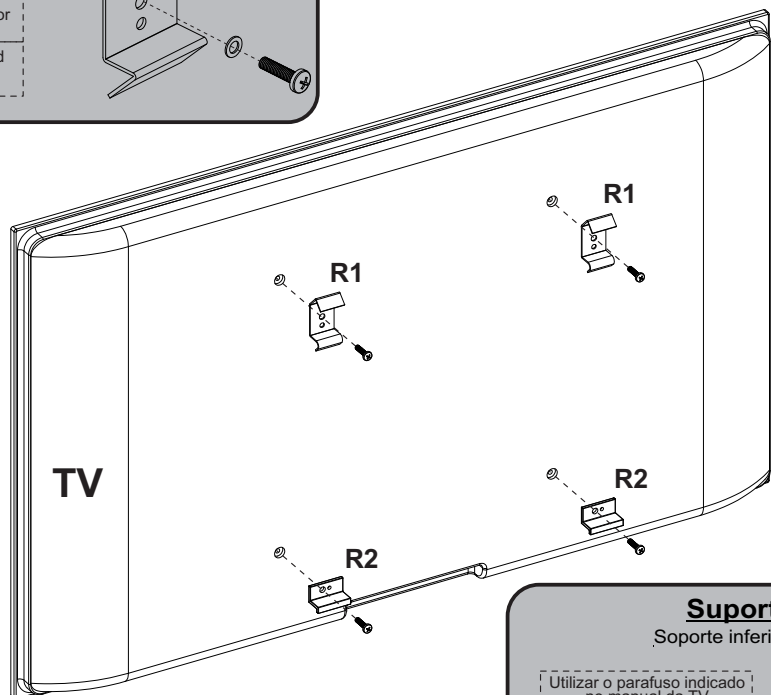
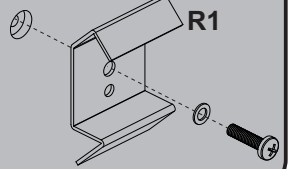

Suporte Inferior

Suporte inferior / Lower support

Utilizar o parafuso indicado no manual da TV R6 / R7(VESA).

Use el tornillo indicado en lo manual del televisor R6 / R7(VESA).

Use the screw indicated in the TV manual R6 / R7(VESA).

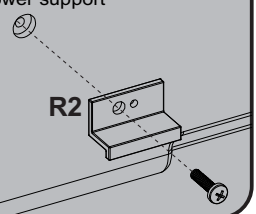

- R1** Kit Suporte TV **02**
- R2** Kit Suporte TV **02**

18

Passo
Paso
Step

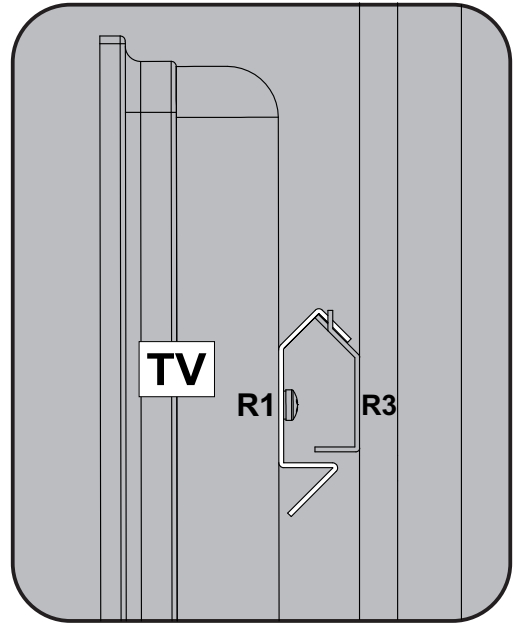
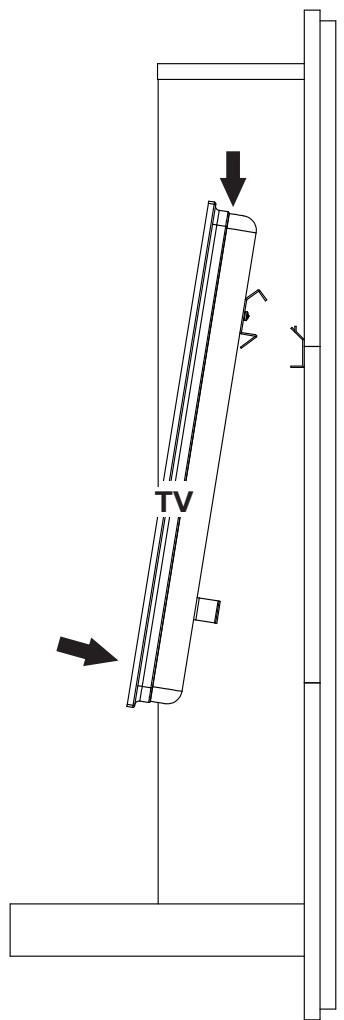

19

Passo
Paso
Step

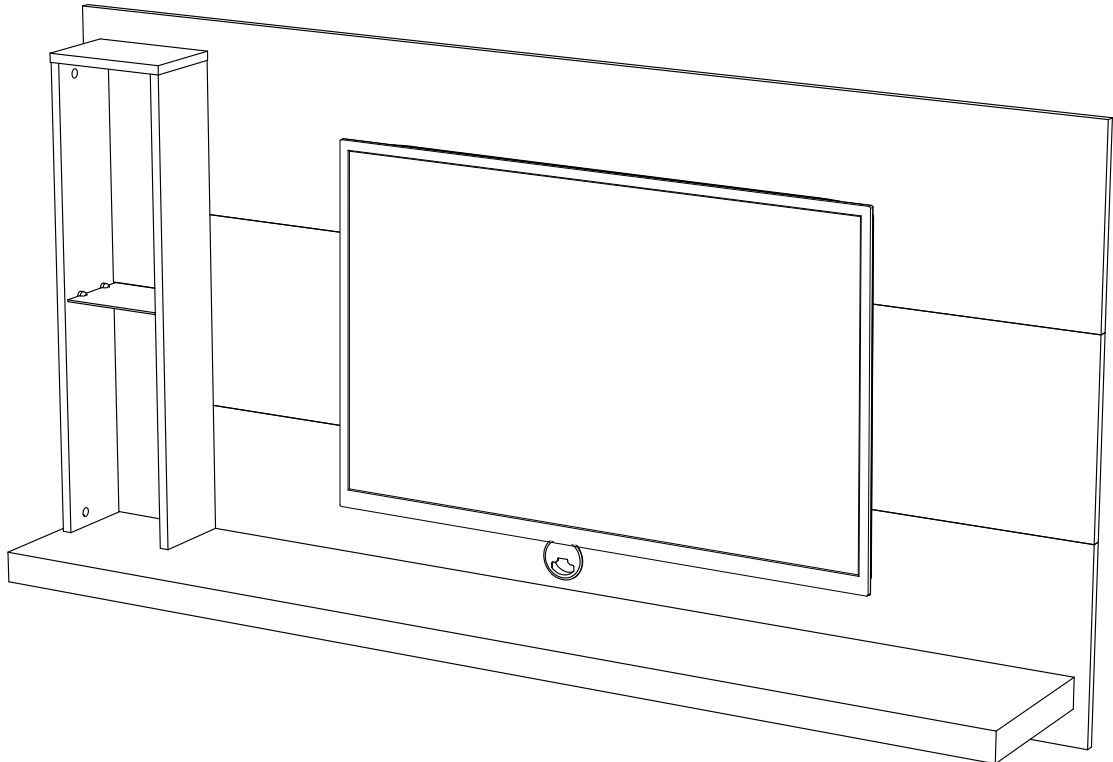

Garantia

Este certificado de Garantia é uma vantagem adicional oferecida ao consumidor, porém para que o mesmo tenha validade é imprescindível que seja apresentada a NOTA FISCAL de compra do produto.

Com este produto, a **Artely** tem como objetivo atender plenamente o proprietário-consumidor, proporcionando a garantia na forma aqui estabelecida, pelo período de três meses a partir da data da nota fiscal de compra. A **Artely** restringe a sua responsabilidade à substituição gratuita das peças defeituosas, em caso de defeitos ou avarias devidamente constatados como sendo de fabricação, durante a vigência desta garantia.

A **Artely** declara a garantia nula e sem efeito se o produto for alterado, adulterado, molhado ou consertado e ainda pela prática de montagem inadequada ou mau uso. Também será considerada nula em casos de força maior, como aqueles causados por agentes da Natureza (chuvas, incêndios, excesso de umidade, cupins...) e eventos externos como objetos arrastados sobre a superfície do móvel (ex.: TV, DVD, aparelho de som, objetos decorativos...).

Para exercer seus direitos de comprador é importante que antes de montar seu produto você leia com atenção as instruções de cada passo do manual de montagem que acompanha o móvel.

Caso o produto não esteja em conformidade, entre em contato com a loja onde efetuou a compra ou com o nosso Serviço de Atendimento ao Cliente através do e-mail assistencia@artely.com.br ou pelo fone 41 3381 5000 e faça sua reclamação, apontando os defeitos técnicos observados, que teremos o maior prazer em atendê-lo. Para agilizar o seu atendimento, tenha sempre em mãos o manual de montagem com os respectivos números das peças defeituosas, conforme descritas no manual.



ARTELY MÓVEIS LTDA
ALAMEDA ARPO, 2333
CEP / ZIP CODE: 83010-290
SÃO JOSÉ DOS PINHAIS
CURITIBA - PR - BRASIL
Fone / Fax: 41 3381-5000
Phone Number: 55 41 3381-5000
e-mail: artely@artely.com.br
www.artely.com.br