

INSTRUÇÕES DE MONTAGEM

INSTRUCCIONES DE MONTAJE

ASSEMBLY INSTRUCTIONS

Cozinha Compacta Americana 4 Peças com Aéreo para Geladeira | Americana Compact Kitchen 4 Piezas con Aire para Refrigerador | Americana Compact Kitchen 4 Pieces with Air for Refrigerator

CE379-05 Branco HP

Requisitos para montagem
Requisitos para la montaje
Assembly Requirements

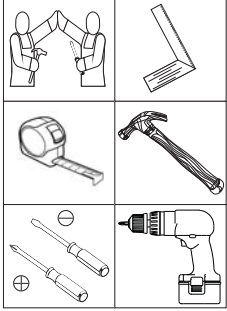

Imagens meramente ilustrativas
Imágenes meramente ilustrativas
Images for illustration only

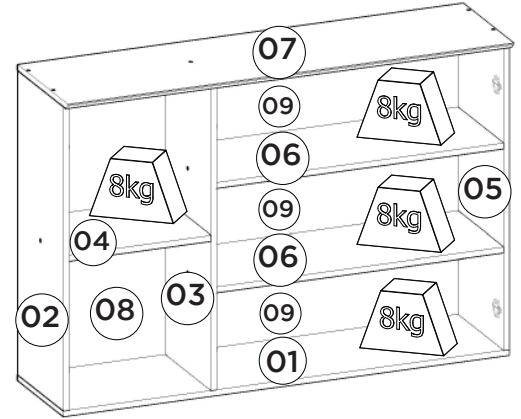
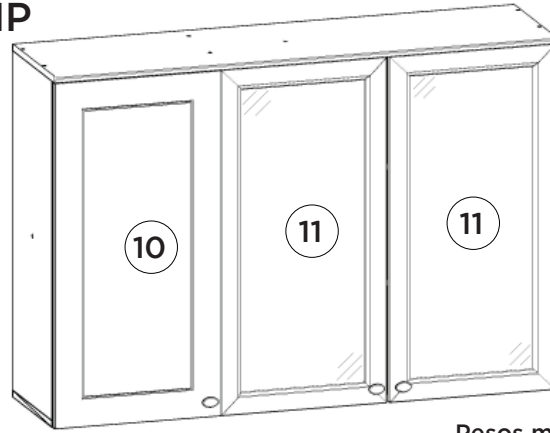

Pesos máximos recomendados com carga distribuída
Peso máximo recomendado con la carga distribuida
Recommended maximum weight with distributed load.

Lista de Peças | Lista de piezas | List of parts

Item	Caixa Caja Box	Qtd Ctd Qty	Descrição Descripción Description	Medidas (mm) Dimensions (mm) Size (measurements) (mm)
01	1/1	01	Base Base Base	1200x295x15
02	1/1	01	Lateral Esquerda Lateral Izquierda Right Left	800x295x15
03	1/1	01	Divisão División Division	800x295x15
04	1/1	01	Prateleira Menor Estante Pequeño Smaller Shelf	382x295x15
05	1/1	01	Lateral Direita Lateral Derecha Right Side	800x295x15
06	1/1	02	Prateleira Estante Shelf	772x295x15
07	1/1	01	Tampo Tapa Top	1200x322x15
08	1/1	01	Fundo Lateral Fondo Lateral Lateral Background	824x401x3
09	1/1	03	Fundo Fondo Bottom	791x274x3
10	1/1	01	Porta Puerta Door	813x396x15
11	1/1	02	Porta de Vidro Puerta de vidrio Glass door	813x396x15

Ferragens | Herrajes | Hardware

A Parafuso 5,0x50mm FLA. Tornillo 5,0x50mm FLA. Screw 5,0x50mm FLA.	B Parafuso 3,5x40mm CHT. Tornillo 3,5x40mm CHT. Screw 3,5x40mm CHT.	C Parafuso 3,5x14mm FLA. Tornillo 3,5x14mm FLA. Screw 3,5x14mm FLA.	D Parafuso M4x20mm CHT. ZB Tornillo M4x20mm CHT. ZB Screw M4x20mm CHT. ZB	E Cavilha 8x25mm Cinta 8x25mm Dowel 8x25mm	F Calço Removível Calzado extraíble Removable Shim
G Dobradica SlideOn Baixa Amortecedor 35mm Bisagra SlideOn Baja Amortiguador 35mm Low SlideOn Hinge 35mm Shock Absorber	H Puxador Pontual PZ14 Oval Tirador Puntual PZ14 Oval Oval Point Knob	I Buchas plásticas 8mm Bucha de plástico 8mm 8mm plastic bushing	J Suporte de fixação Soporte de fijación Mounting bracket	K Proteção para cantoneira Ángulo de protección Protection angle	L Parafuso União 30mm Tornillo Unión 30mm Union Screw 30mm
M Giz de correção Tiza de corrección Chalk of correction	N Sachê de cola Bolsa de pegamento Glue bag	O Adesivo tapa parafuso 10mm Adhesivo tapón de tornillo 10mm Bolt cover adhesive 10mm	P Fixador de fundos Fijador de fondos Bottom fixer	Q Prego 10x10mm Clavo 10x10mm Nail 10x10mm	R Etiqueta resinada Henn Etiqueta resinada Henn Henn resin label

O parafuso (L) deve ser usada somente quando este módulo for acoplado a outro módulo componível Henn.

El tornillo (L) se debe utilizar sólo cuando el módulo está conectado a otro módulo componible Henn.

The screw (L) should be used only when this module is attached to another Henn modular module.

RECOMENDAÇÃO

Para fixar o móvel na parede usar o suporte de fixação (J), o parafuso 3,5x14mm FLA (C), a Bucha 8mm (I) e o parafuso 5,0x50mm FLA (A).

RECOMENDACIÓN

Para conectar el móvil a la pared con el soporte (J), tornillo 3,5 x14mm FLA (C), el casquillo de 8 mm (I) y el 5,0 x50mm tornillo FLA (A).

RECOMMENDATION

To fix the furniture to the wall use the fixing bracket (J), the 3.5x14mm FLA (C) screw, the 8mm bushing (I) and the 5.0x50mm FLA screw (A).

1º

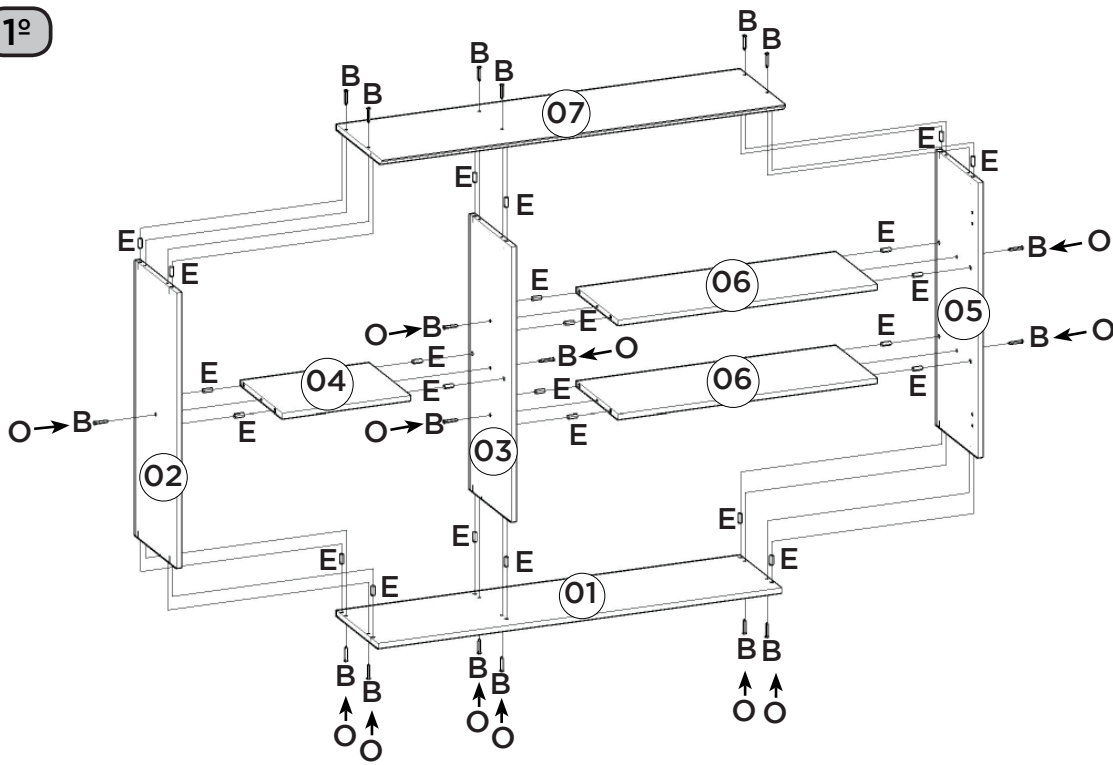

Utilizar o sachê de cola (N) em todas as cavilhas (E) do produto.

Con el pegamento sobre (N) en todos los pernos (E) producto.

Use the glue sachet (N) on all the pegs (E) of the product.

2º

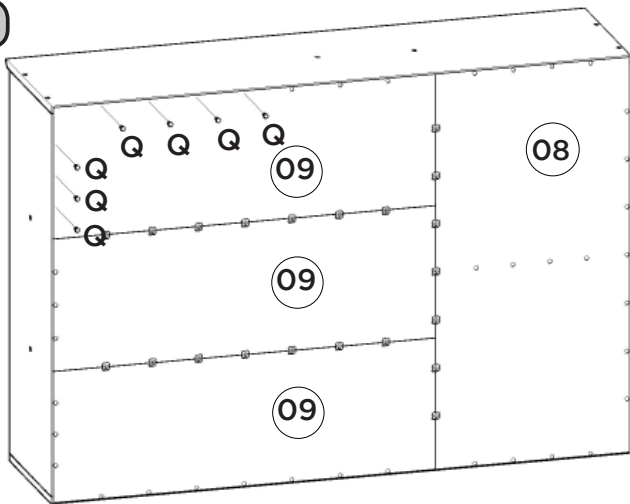

AVISO
Para limpeza de seu móvel, use uma flanela seca ou umedecida, e não utilize produtos químicos que possam danificar seu produto.

SISTEMA DE MONTAGEM
O sistema de montagem dos produtos, funciona de acordo com a ordem crescente dos números indicados no desenho. Ex: 01, 02, 03, 04... até a conclusão da montagem.

ADVERTENCIA
Para limpieza de su móvil, use una flanela seca o húmeda, y no utilice productos químicos que puedan dañar su producto.

3º

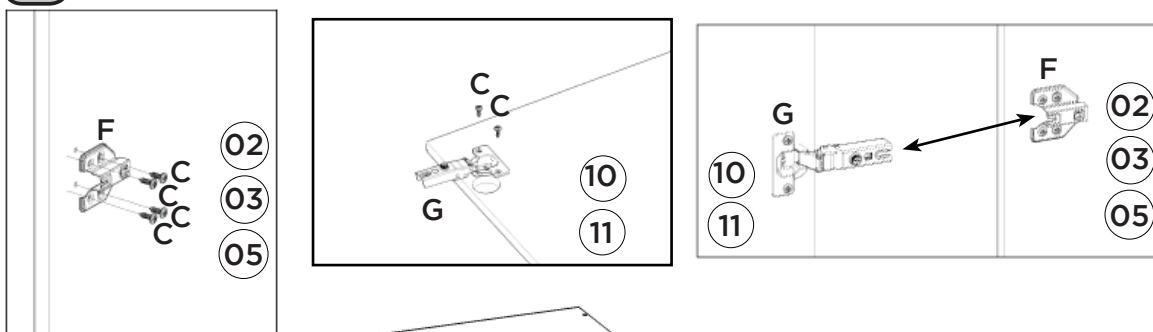

SISTEMA DE MONTAJE
El sistema de montaje de los productos funciona de acuerdo con el orden creciente de los números indicados en el dibujo. Ej.: 01, 02, 03, 04... hasta la conclusión del montaje.

NOTICE
To clean your furniture, use a dry or wet cloth, and do not use chemicals that may damage your product.

ASSEMBLY SYSTEM
The products' assembly system works according to the increasing order of the indicated numbers. For example: 01, 02, 03, 04 ... to the end of the assembly.

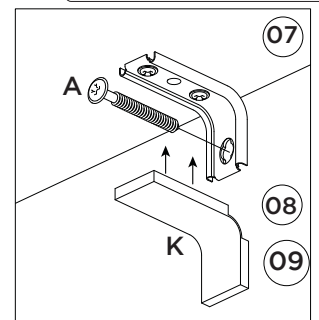
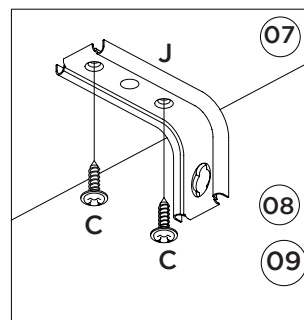
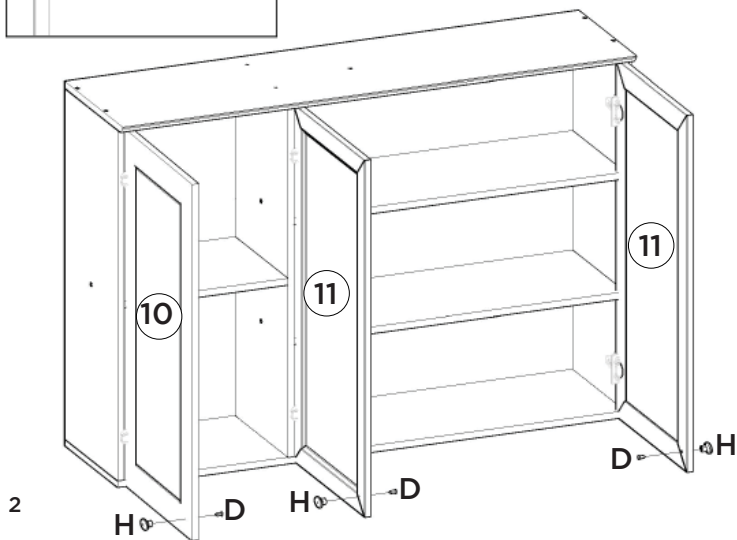

INSTRUÇÕES DE MONTAGEM

INSTRUCCIONES DE MONTAJE ASSEMBLY INSTRUCTIONS

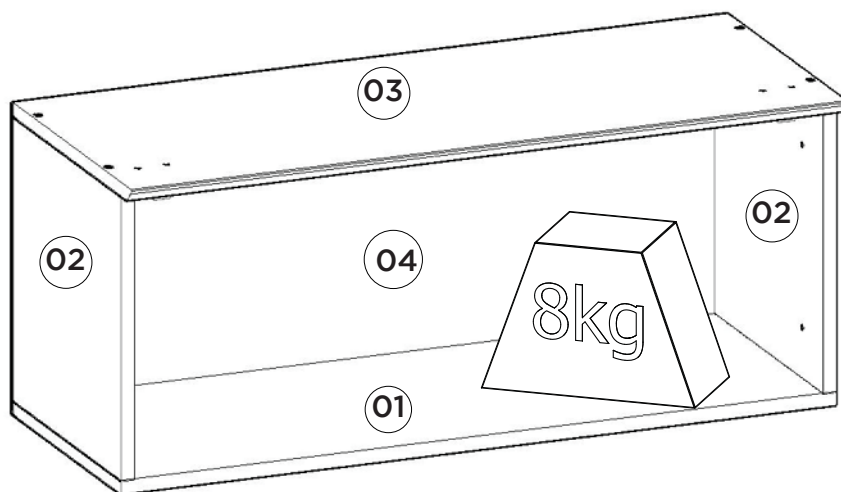
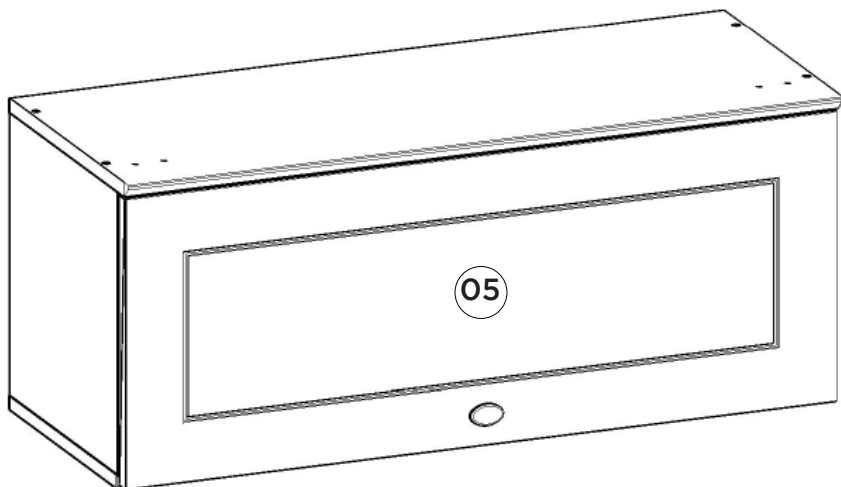

Pesos máximos recomendados com carga distribuída
Peso máximo recomendado con la carga distribuida
Recommended maximum weight with distributed load.

Requisitos para montagem Requisitos para la montaje Assembly Requirements

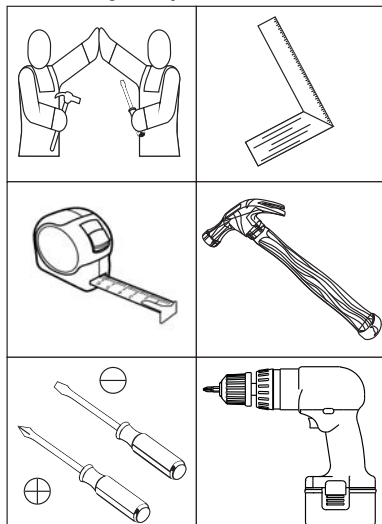

Imagens meramente ilustrativas
Imágenes meramente ilustrativas
Images for illustration only

AVISO

Para limpeza de seu móvel, use uma flanela seca ou umedecida, e não utilize produtos químicos que possam danificar seu produto.

SISTEMA DE MONTAGEM

O sistema de montagem dos produtos, funciona de acordo com a ordem crescente dos números indicados no desenho. Ex: 01, 02, 03, 04... até a conclusão da montagem.

ADVERTENCIA

Para limpieza de su móvil, use una franela seca o húmeda, y no utilice productos químicos que puedan dañar su producto.

SISTEMA DE MONTAJE

El sistema de montaje de los productos funciona de acuerdo con el orden creciente de los números indicados en el dibujo. Ej.: 01, 02, 03, 04... hasta la conclusión del montaje.

NOTICE

To clean your furniture, use a dry or wet cloth, and do not use chemicals that may damage your product.

ASSEMBLY SYSTEM

The products' assembly system works according to the increasing order of the indicated numbers. For example: 01, 02, 03, 04 ... to the end of the assembly.

1º

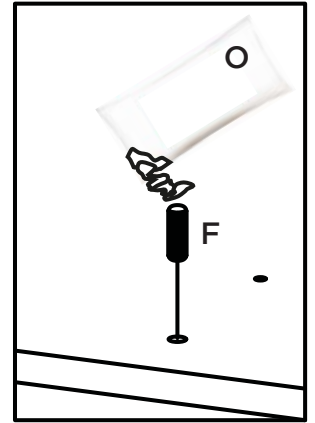
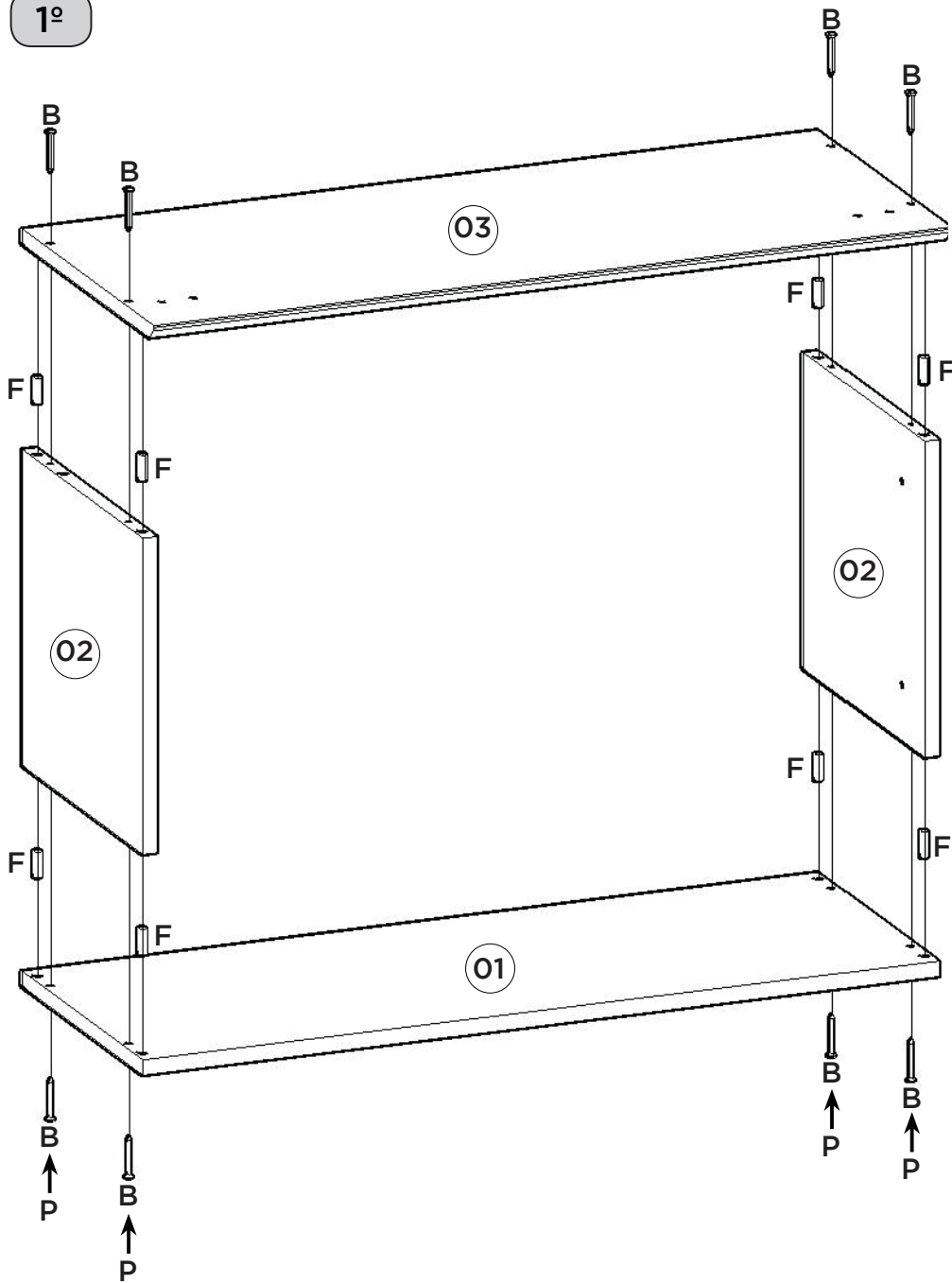

Utilizar o sachê de cola (O) em todas as cavilhas (F) do produto.

Con el pegamento sobre (O) en todos los pernos (F) producto.

Use the glue sachet (O) on all the pegs (F) of the product.

2º

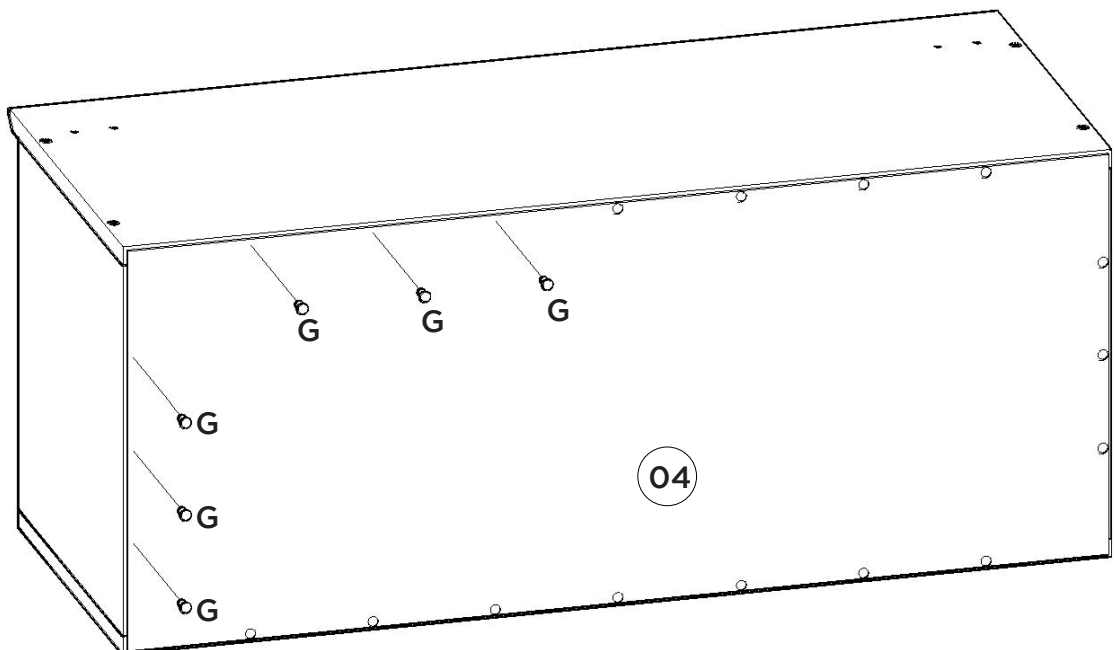

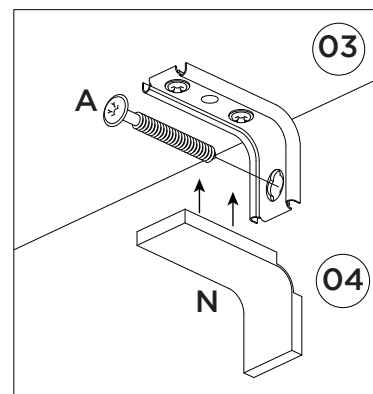
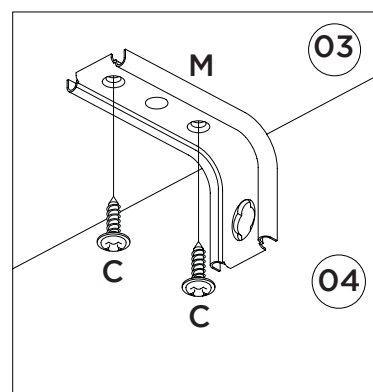
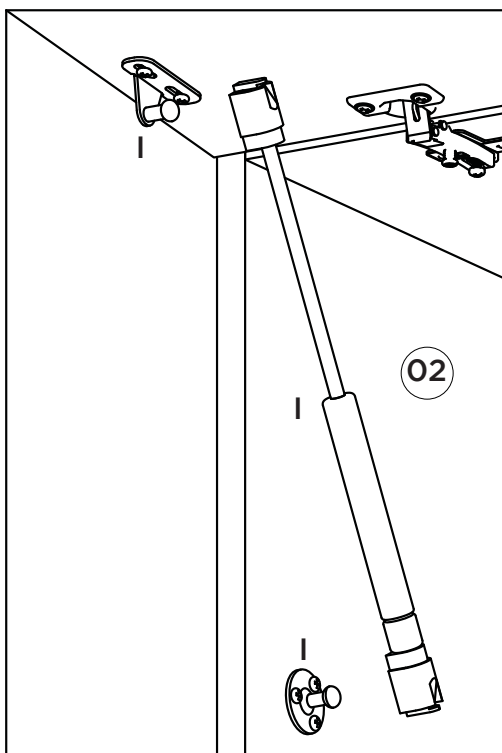
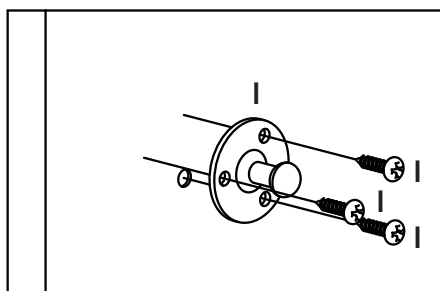
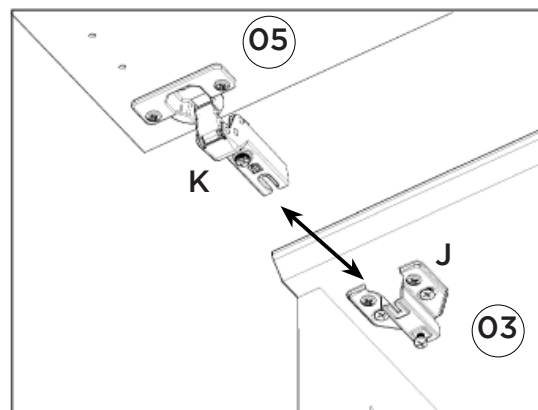
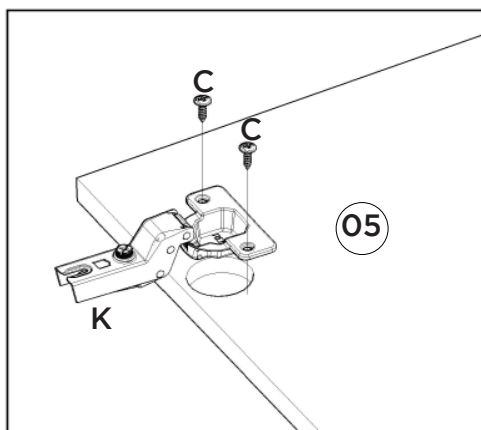
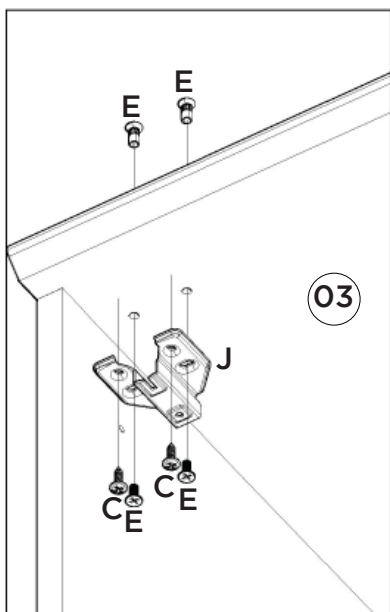
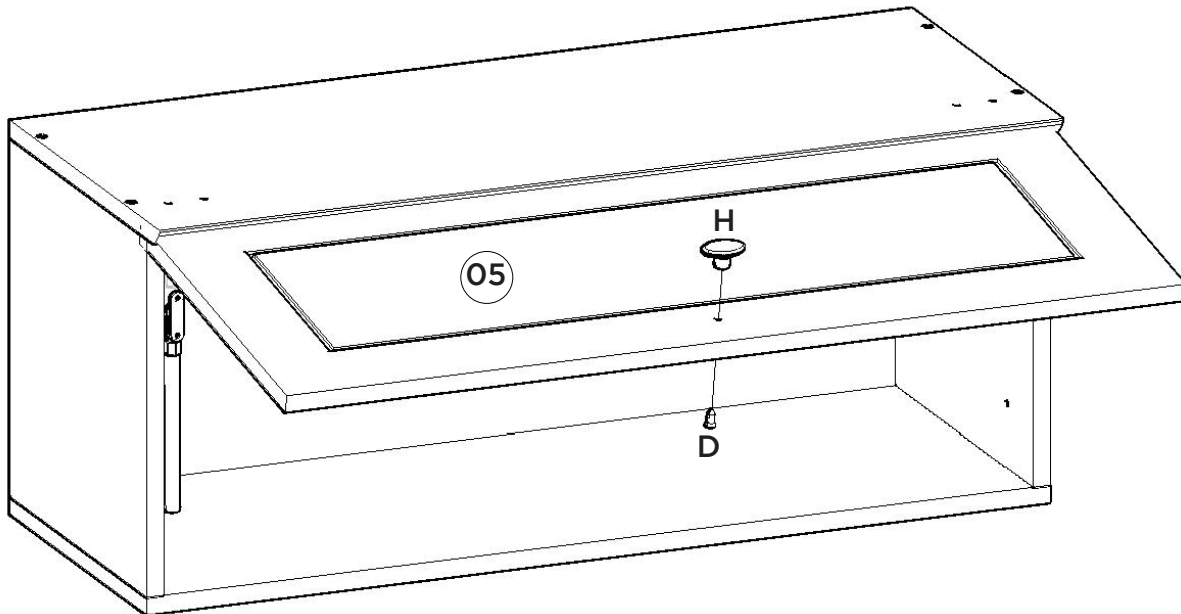







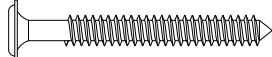

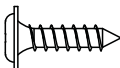

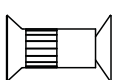
Lista de Peças | Lista de piezas | List of parts

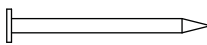
Item	Caixa Caja Box	Qtd Ctd Qty	Descrição Descripción Description	Medidas (mm) Dimensions (mm) Size (measurements) (mm)
01	1/1	01	Base Base Base	800x295x15
02	1/1	02	Lateral Direita Esquerda Lateral Derecha Izquierda Right Side Left	307x295x15
03	1/1	01	Tampo Tapa Top	800x322x15
04	1/1	01	Fundo Fondo Bottom	793x331x3
05	1/1	01	Porta Basculante Puerta Basculante Basculating Door	796x315x15

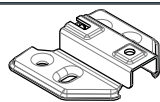
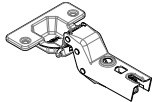
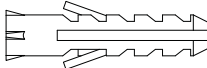
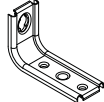
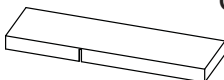
Ferragens | Herrajes | Hardware

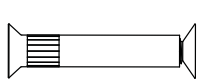
A  Parafuso 5,0x50mm FLA. Tornillo 5,0x50mm FLA. Screw 5,0x50mm FLA.	02x	B  Parafuso 3,5x40mm CHT. Tornillo 3,5x40mm CHT. Screw 3,5x40mm CHT.	08x	C  Parafuso 3,5x14mm FLA. Tornillo 3,5x14mm FLA. Screw 3,5x14mm FLA.	12x	D  Parafuso M4x20mm CHT. ZB Tornillo M4x20mm CHT. ZB Screw M4x20mm CHT. ZB	01x	E  Parafuso União 15mm Tornillo Unión 15mm Union Screw 15mm	04x
F  Cavilha 8x25mm Cinta 8x25mm Dowel 8x25mm	08x	G  Prego 10x10mm Clavo 10x10mm Nail 10x10mm	20x	H  Puxador Pontual PZ14 Oval Tirador Puntual PZ14 Oval PZ14 Oval Point Knob	01x	I  Kit Pistão a Gás 60N Kit Pistón a Gas 60N 60N Gas Piston Kit	01x	J  Calço Removível Calzado extraíble Removable Shim	02x
K  Dobradiça SlideOn Super Alta Amort. 35mm Bisagra Super high amort de Slideon. 35mm Slideon Super High Amort hinge. 35mm	02x	L  Bucha plástica 8mm Bucha de plástico 8mm 8mm plastic bushing	02x	M  Suporte de fixação Soporte de fijación Mounting bracket	02x	N  Proteção para cantoneira Ángulo de protección Protection angle	02x	O  Sachê de cola Bolsa de pegamento Glue bag	01x
P  Adesivo tapa parafuso 10mm Adhesivo tapón de tornillo 10mm Bolt cover adhesive 10mm	08x	Q  Parafuso União 30mm Tornillo Unión 30mm Union Screw 30mm	04x						



O parafuso (Q) deve ser usada somente quando este módulo for acoplado a outro módulo componível Henn.

RECOMENDAÇÃO

Para fixar o móvel na parede usar o suporte de fixação (M), o parafuso 3,5x14mm FLA (C), a Bucha 8mm (L) e o parafuso 5,0x50mm FLA (A).



El tornillo (Q) se debe utilizar sólo cuando el módulo está conectado a otro módulo componible Henn.

RECOMENDACIÓN

Para conectar el móvil a la pared con el soporte (M), tornillo 3,5 x14mm FLA (C), el casquillo de 8 mm (L) y el 5,0 x50mm tornillo FLA (A).



The screw (Q) should be used only when this module is attached to another Henn modular module.

RECOMMENDATION

To fix the furniture to the wall use the fixing bracket (M), the 3.5x14mm FLA (C) screw, the 8mm bushing (L) and the 5.0x50mm FLA screw (A).

INSTRUÇÕES DE MONTAGEM

INSTRUCCIONES DE MONTAJE ASSEMBLY INSTRUCTIONS



Requisitos para montagem
Requisitor para la montaje
Assembly Requirements

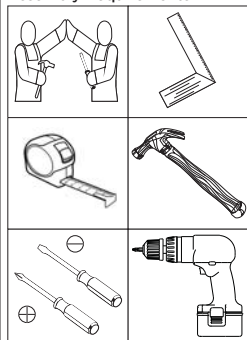

Imagens meramente ilustrativas
Imágenes meramente ilustrativas
Images for illustration only

OPCIONAL:
O944-121 Kit Pé Cônico 145mm (vendido separadamente). Caso opte em colocar pé no produto, utilizar as pré-furações que possui na Base e fixá-lo com o Parafuso que consta no Kit.

OPCIONAL:
O944-121 Kit Pie Cónico 145mm (se vende por separado). Si opta por colocar pie en el producto, utilizar las pre-huracuras que tenga en la Base y fijarlo con el Tornillo que consta en el Kit.

OPTIONAL:
O944-121 Tapered Foot Kit 145mm (sold separately). If you choose to put foot in the product, use the pre-drillings in the Base and fix it with the Screw included in the Kit.

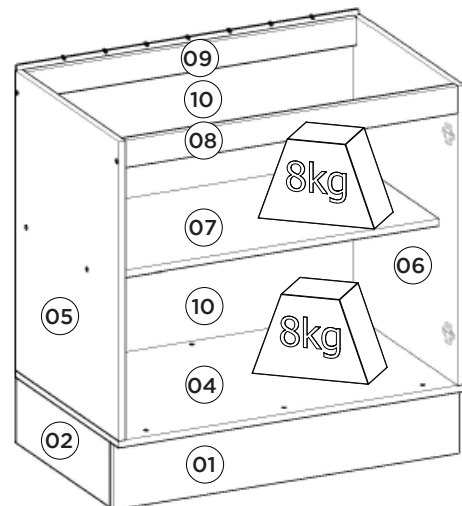
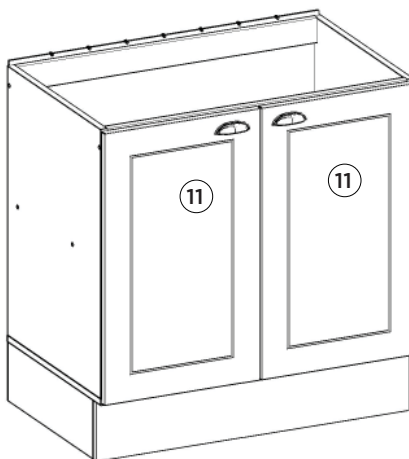

Pesos máximos recomendados com carga distribuída
Peso máximo recomendado con la carga distribuida
Recommended maximum weights with evenly distributed.

Lista de Peças | Lista de piezas | List of parts

Item	Caixa Caja Box	Qtd Ctd Qty	Descrição Descripción Description	Medidas (mm) Dimensions (mm) Size (measurements) (mm)
01	1/1	01	Rodapé Frontal Frente pie de página Front Footer	800x145x15
02	1/1	02	Rodapé Lateral Pie de página Side Side Footer	450x145x15
03	1/1	01	Rodapé Traseiro Pie de página trasera Rear Footer	768x145x15
04	1/1	01	Base Base Base	800x490x15
05	1/1	01	Lateral esquerda Lateral izquierda Left side	660x490x15
06	1/1	01	Lateral direita Lateral derecha Right side	660x490x15
07	1/1	01	Prateleira Estante Shelf	769x400x15
08	1/1	01	Travessa frontal Travesaño frontal Front crossbar	769x60x15
09	1/1	01	Travessa traseira Travesaño trasero Rear bumper	769x60x15
10	1/1	02	Fundo Fondo Bottom	792x341x3
11	1/1	02	Porta Puerta Door	665x396x15

AVISO

Para limpeza de seu móvel, use uma flanela seca ou umedecida, e não utilize produtos químicos que possam danificar seu produto.

SISTEMA DE MONTAGEM

O sistema de montagem dos produtos, funciona de acordo com a ordem crescente dos números indicados no desenho. Ex: 01, 02, 03, 04... até a conclusão da montagem.

ADVERTENCIA

Para limpieza de su móvil, use una flanela seca o húmeda, y no utilice productos químicos que puedan dañar su producto.

SISTEMA DE MONTAJE

El sistema de montaje de los productos funciona de acuerdo con el orden creciente de los números indicados en el dibujo. Ej.: 01, 02, 03, 04... hasta la conclusión del montaje.

NOTICE

To clean your furniture, use a dry or wet cloth, and do not use chemicals that may damage your product.

ASSEMBLY SYSTEM

The products' assembly system works according to the increasing order of the indicated numbers. For example: 01, 02, 03, 04 ... to the end of the assembly.

Ferragens | Herrajes | Hardware

A 04x Parafuso 5,0x50mm FLA. Tornillo 5,0x50mm FLA. Screw 5,0x50mm FLA.	B 03x Parafuso 4,5x50mm CHT. Tornillo 4,5x50mm CHT. Screw 4,5x50mm CHT.	C 18x Parafuso 3,5x40mm CHT. Tornillo 3,5x40mm CHT. Screw 3,5x40mm CHT.	D 44x Parafuso 3,5x14mm FLA. Tornillo 3,5x14mm FLA. Screw 3,5x14mm FLA.	E 07x Parafuso 3,5x12mm CHT. Tornillo 3,5x12mm CHT. Screw 3,5x12mm CHT.	F 04x Parafuso M4x20mm CHT. ZB Tornillo M4x20mm CHT. ZB Screw M4x20mm CHT. ZB	G 04x Parafuso União 30mm Tornillo Unión 30mm Union Screw 30mm	H 24x Cavilha 8x25mm Cinta 8x25mm Dowel 8x25mm
I 27x Prego 10x10mm Clavo 10x10mm Nail 10x10mm	J 07x Fixador de fundos Fijador de fondos Bottom fixer	K 08x Cantoneira plástica Cantонера plástica Plastic angle brackets	L 02x Puxador Concha Tirador Concha Shell Handle	M 04x Calço Removível Calzado extraíble Removable Shim	N 04x Dobradica SlideOn Baja Amortecedor 35mm Bisagra SlideOn Baja Amortiguador 35mm Low SlideOn Hinge 35mm Shock Absorber	O 04x Buchas plásticas 8mm Buchas de plástico 8mm 8mm plastic bushing	P 02x Suporte de fixação Soporte de fijación Mounting bracket
Q 02x Proteção para cantoneira Ángulo de protección Protection angle	R 02x Giz de correção Tiza de corrección Chalk of correction	S 01x Sachê de cola Bolsa de pegamento Glue bag	T 22x Adesivo tapa parafuso 10mm Adhesivo tapón de tornillo 10mm Bolt cover adhesive 10mm	U 04x Prego 12x12mm Anelado Clavo 12x12mm Anillado Ringed Nails 12x12mm	V 04x Sapata "L" 16x20mm Zapata "L" 16x20mm "L" shoe 16x20mm		



O parafuso (G) deve ser usada somente quando este módulo for acoplado a outro módulo componível Henn.



El tornillo (G) se debe utilizar sólo cuando el módulo está conectado a otro módulo componible Henn.



The screw (G) should be used only when this module is attached to another Henn modular module.

RECOMENDAÇÃO

Para fixar o móvel na parede usar o suporte de fixação (P), o parafuso 3,5x14mm FLA (D), a Bucha 8mm (O) e o parafuso 5,0x50mm FLA (A).

RECOMENDACIÓN

Para conectar el móvil a la pared con el soporte (P), tornillo 3,5 x14mm FLA (D), el casquillo de 8 mm (O) y el 5,0 x50mm tornillo FLA (A).

RECOMMENDATION

To fix the furniture to the wall use the mounting bracket (P), the 3.5x14mm FLA (D) screw, the 8mm bushing (O) and the 5.0x50mm FLA (A).

1º

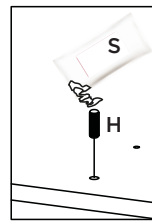
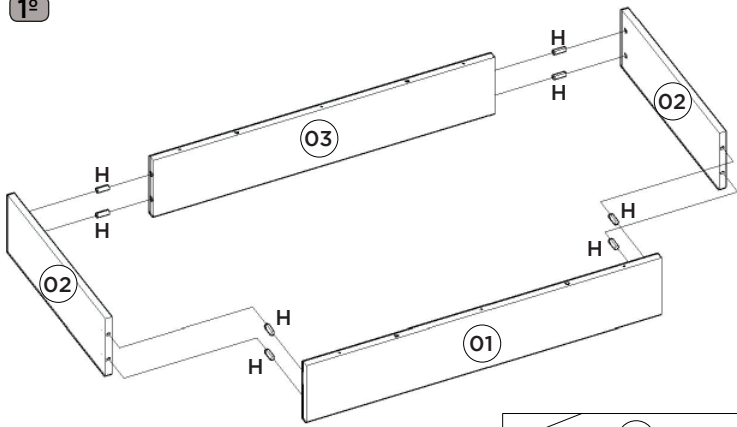

Utilizar o sachê de cola (S) em todas as cavilhas (H) do produto.

Con el pegamento sobre (S) en todos los pernos (H) producto.

Use the glue sachet (S) on all the pegs (H) of the product.

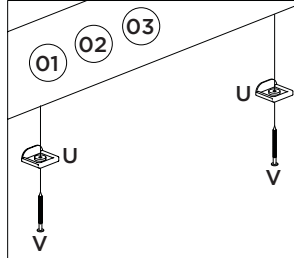
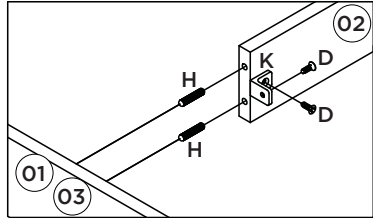

2º

Esse tampo é opcional e é vendido separadamente (C904-114).

Esta vez es opcional y se vende por separado (C904-114).

This top is optional and is sold separately (C904-114).

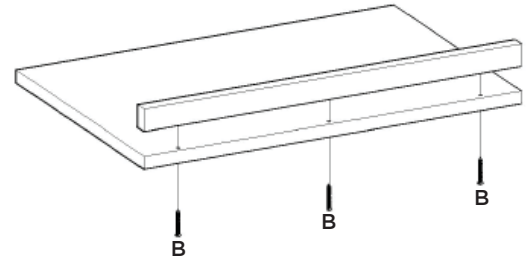

3º

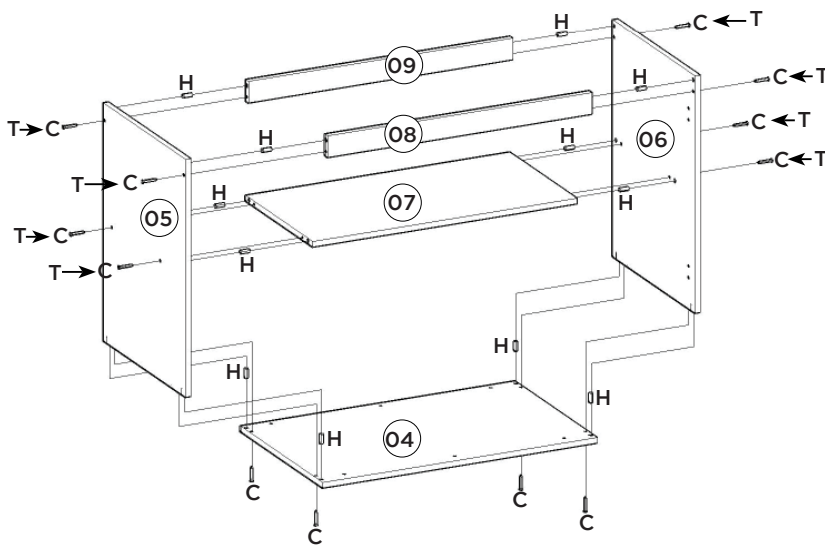

4º

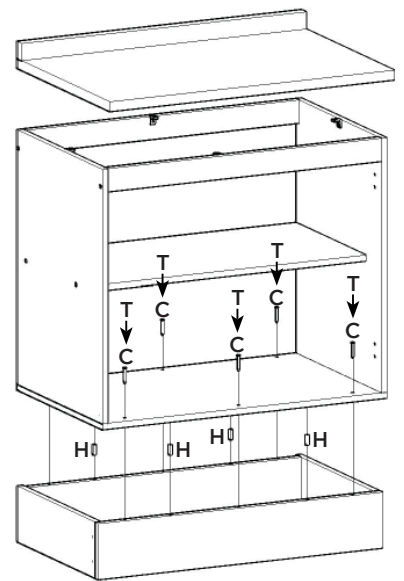
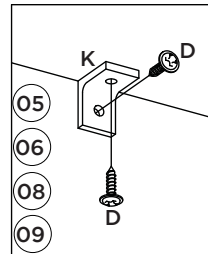

5º

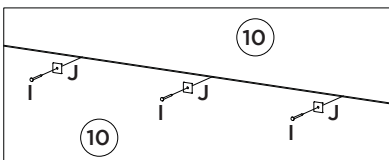
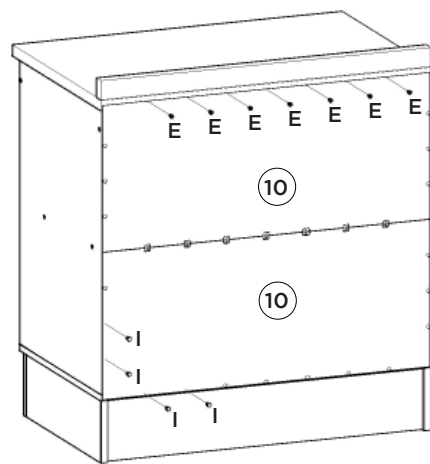

6º

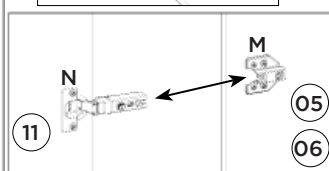
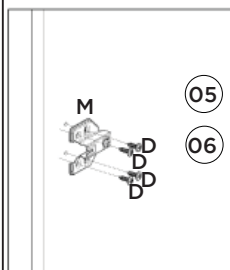
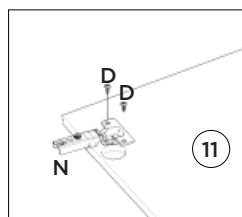
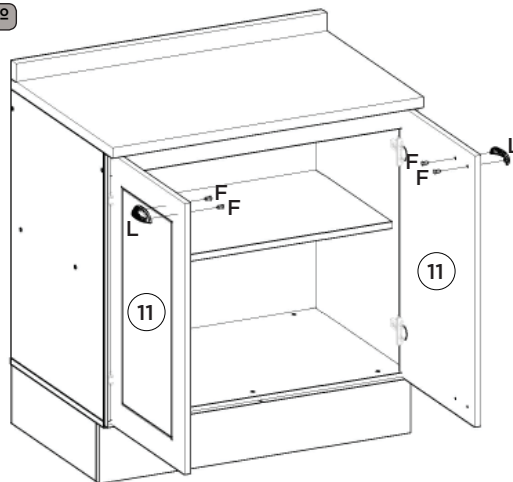

7º

Opção Suspensa

Opción suspendida

Suspended Option

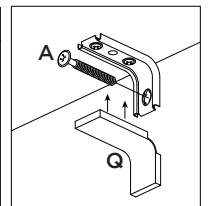
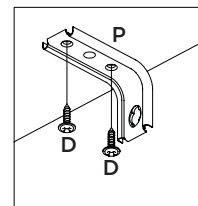

Parede
pared
Wall

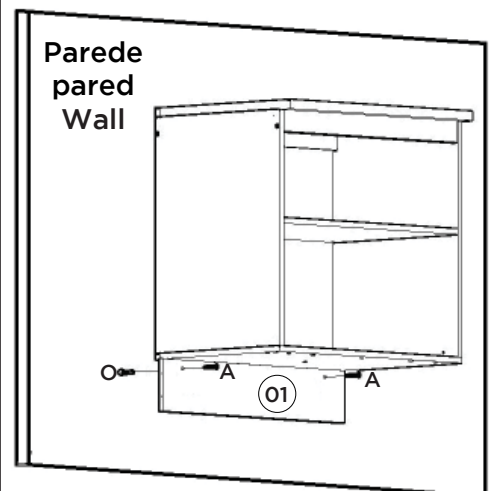

INSTRUÇÕES DE MONTAGEM

INSTRUCCIONES DE MONTAJE ASSEMBLY INSTRUCTIONS

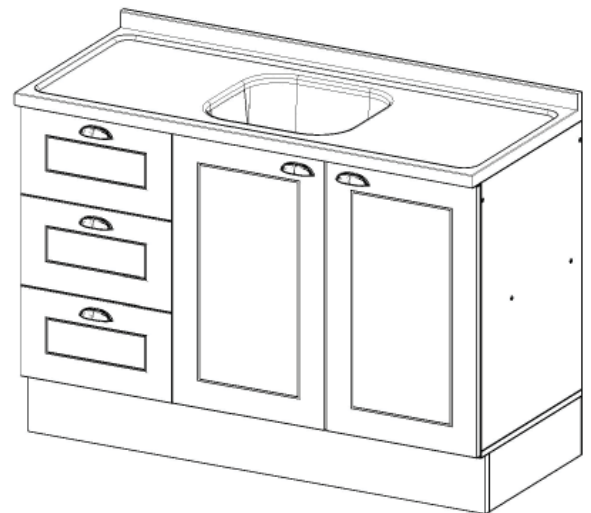
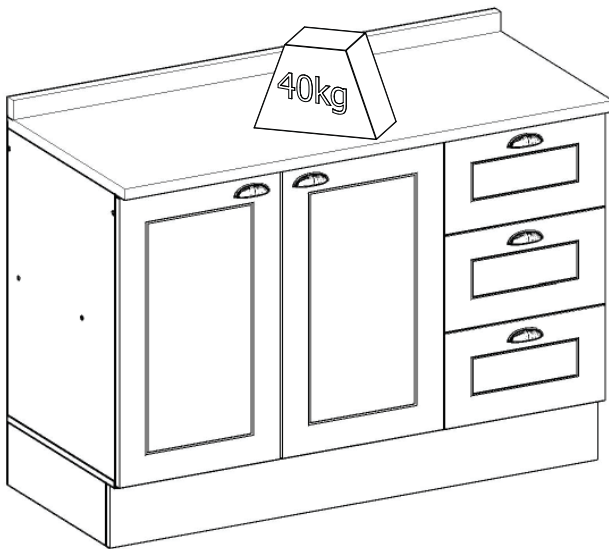
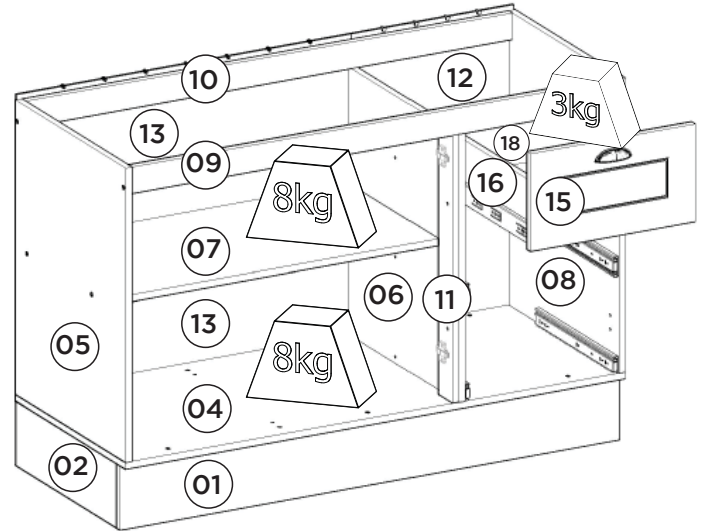
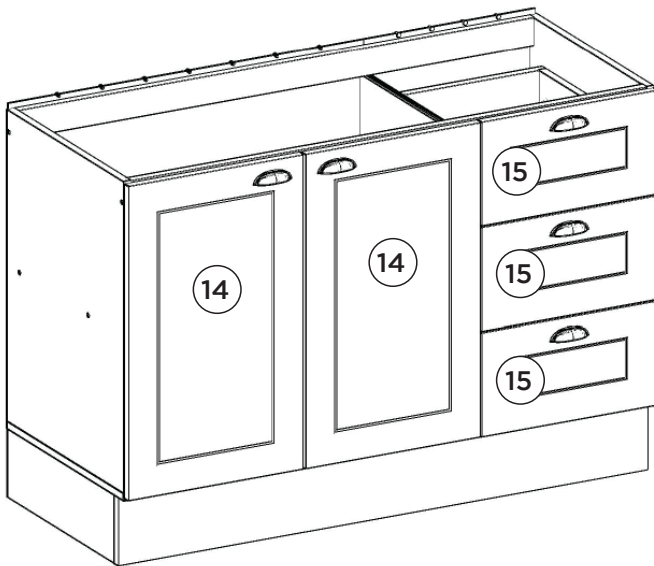

Pesos máximos recomendados com carga distribuída
Peso máximo recomendado con la carga distribuida
Recommended maximum weights with evenly distributed.

Requisitos para montagem Requisitor para la montaje Assembly Requirements

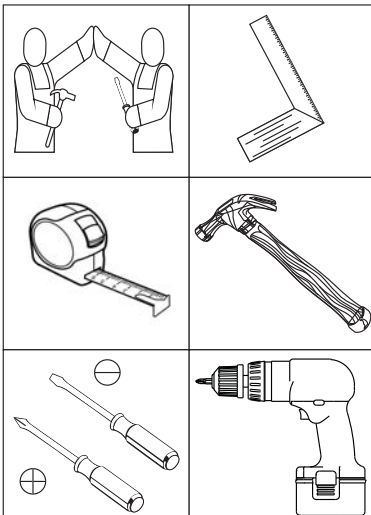

Imagens meramente ilustrativas
Imágenes meramente ilustrativas
Images for illustration only

AVISO

Para limpeza de seu móvel, use uma flanela seca ou umedecida, e não utilize produtos químicos que possam danificar seu produto.

SISTEMA DE MONTAGEM

O sistema de montagem dos produtos, funciona de acordo com a ordem crescente dos números indicados no desenho. Ex: 01, 02, 03, 04... até a conclusão da montagem.

ADVERTENCIA

Para limpieza de su móvil, use una flanela seca o húmeda, y no utilice productos químicos que puedan dañar su producto.

SISTEMA DE MONTAJE

El sistema de montaje de los productos funciona de acuerdo con el orden creciente de los números indicados en el dibujo. Ej.: 01, 02, 03, 04... hasta la conclusión del montaje.

NOTICE

To clean your furniture, use a dry or wet cloth, and do not use chemicals that may damage your product.

ASSEMBLY SYSTEM

The products' assembly system works according to the increasing order of the indicated numbers. For example: 01, 02, 03, 04 ... to the end of the assembly.

1º

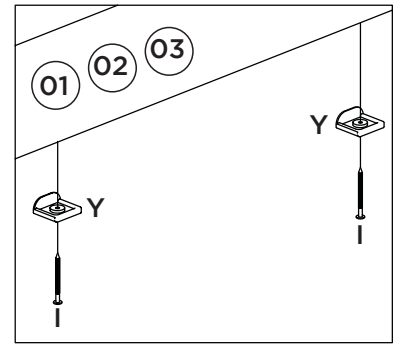
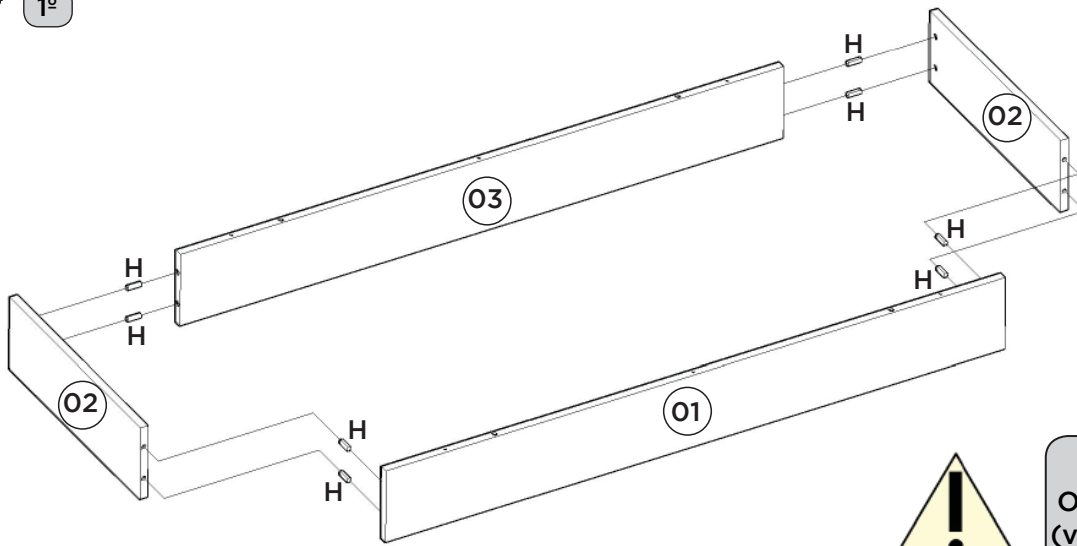

OPCIONAL:
 O945-121 Kit Pé Cônico 145mm (vendido separadamente). Caso opte em colocar pé no produto, utilizar as pré-furações que possui na Base e fixá-lo com o Parafuso que consta no Kit.

OPCIONAL:
 O945-121 Kit Pie Cónico 145mm (se vende por separado). Si opta por colocar pie en el producto, utilizar las pre-huracuras que tenga en la Base y fijarlo con el Tornillo que consta en el Kit.

OPTIONAL:
 O945-121 Tapered Foot Kit 145mm (sold separately). If you choose to put foot in the product, use the pre-drillings in the Base and fix it with the Screw included in the Kit.

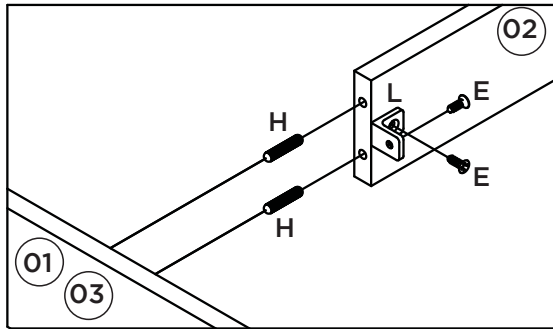

2º

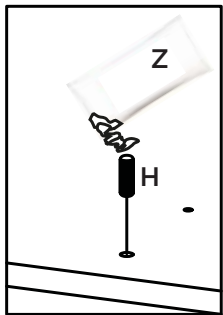

Utilizar o sachê de cola (Z) em todas as cavilhas (H) do produto.

Con el pegamento sobre (Z) en todos los pernos (H) producto.

Use the glue sachet (Z) on all the pegs (H) of the product.

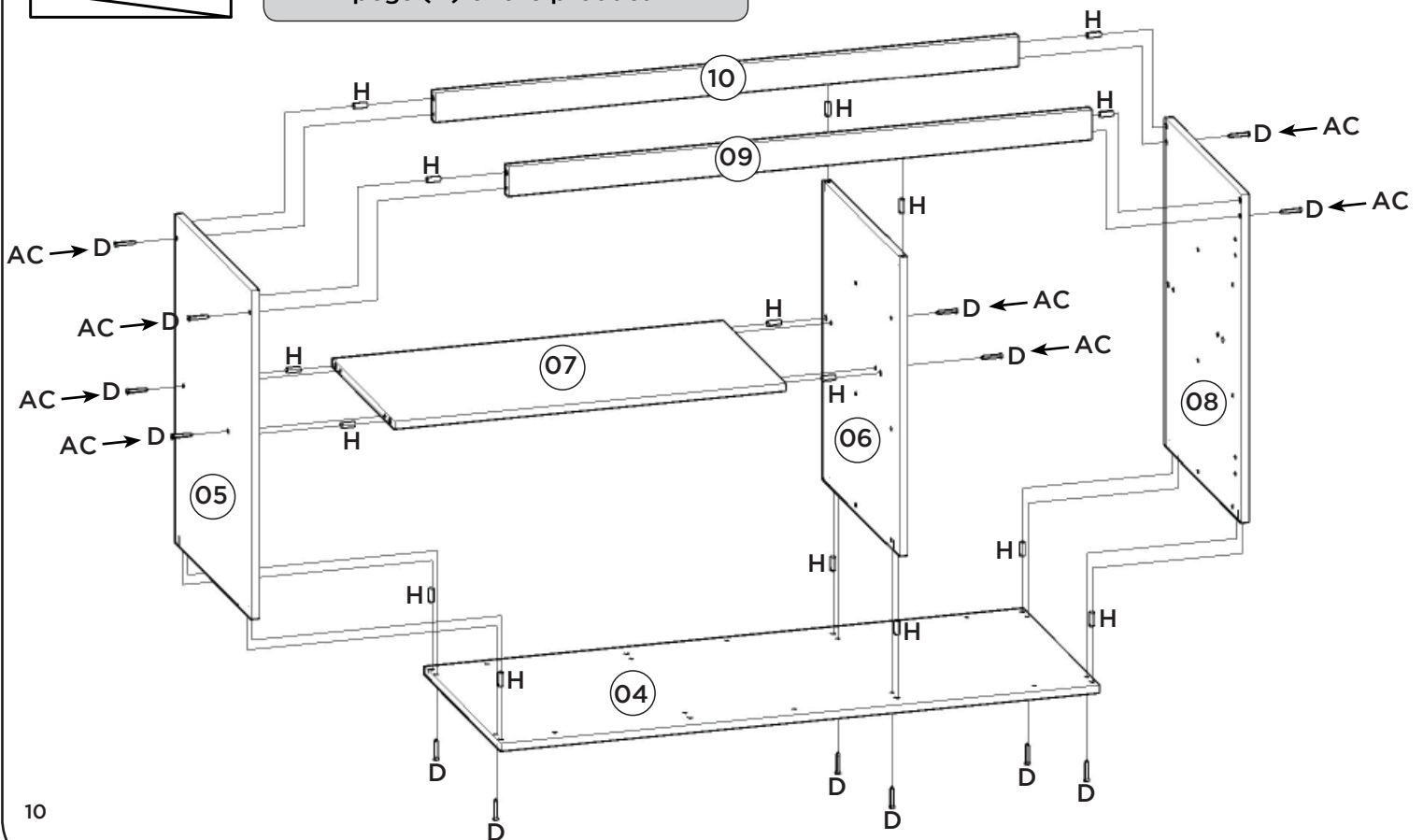

3º

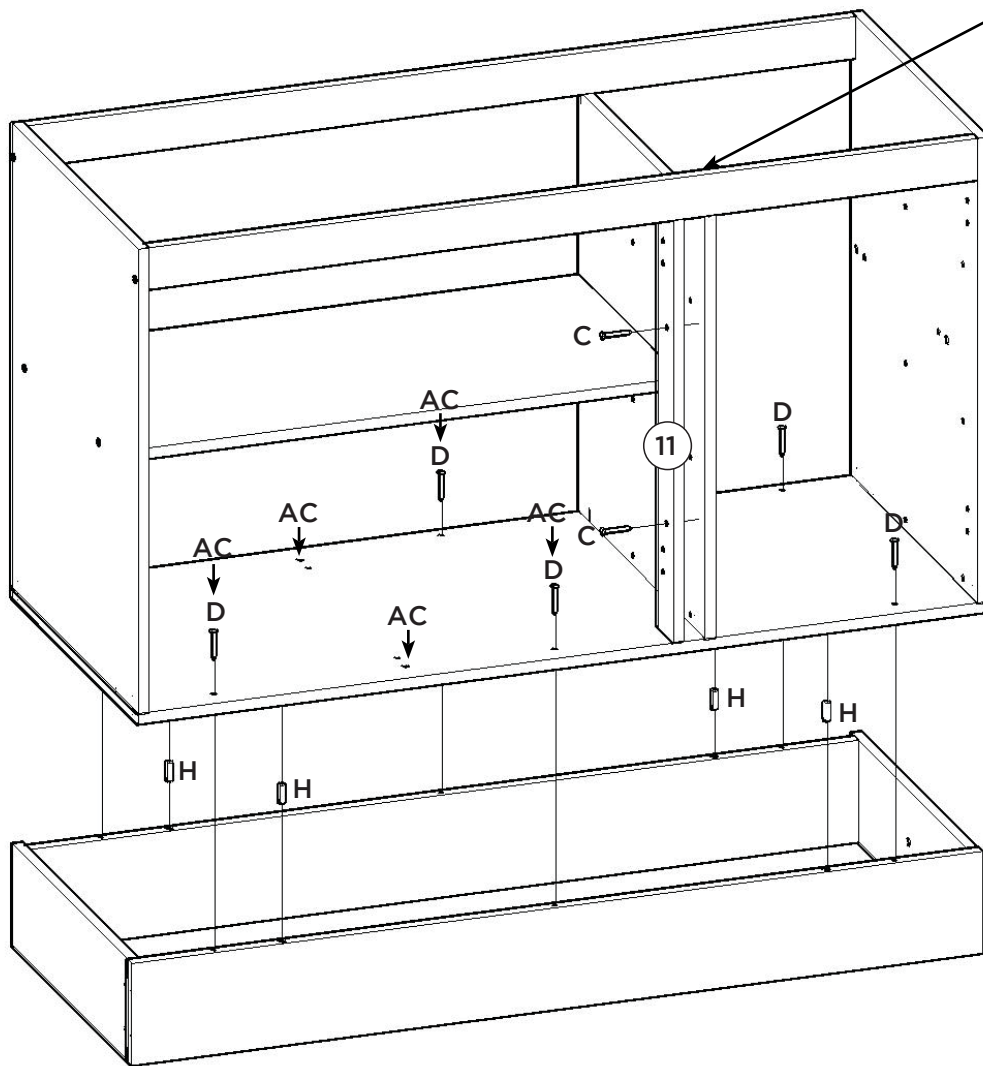

A pilastra da porta (11) deve estar alinhada com a divisão (06).

El pilar de la puerta (11) debe estar alineada con la división (06).

The door pillar (11) must be aligned with the partition (06).

4º

Esse tampo é opcional e é vendido separadamente (C905-114).

Esta vez es opcional y se vende por separado (C905-114).

This top is optional and is sold separately (C905-114).

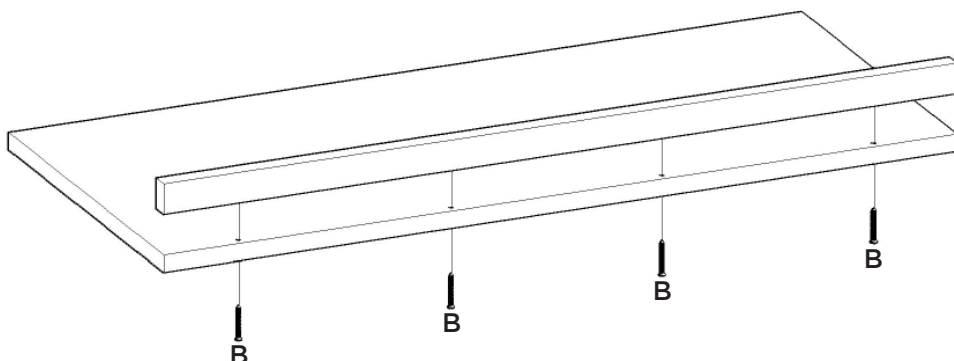

5°

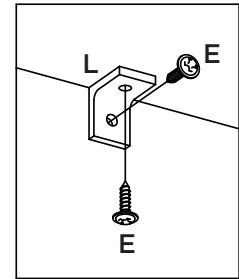
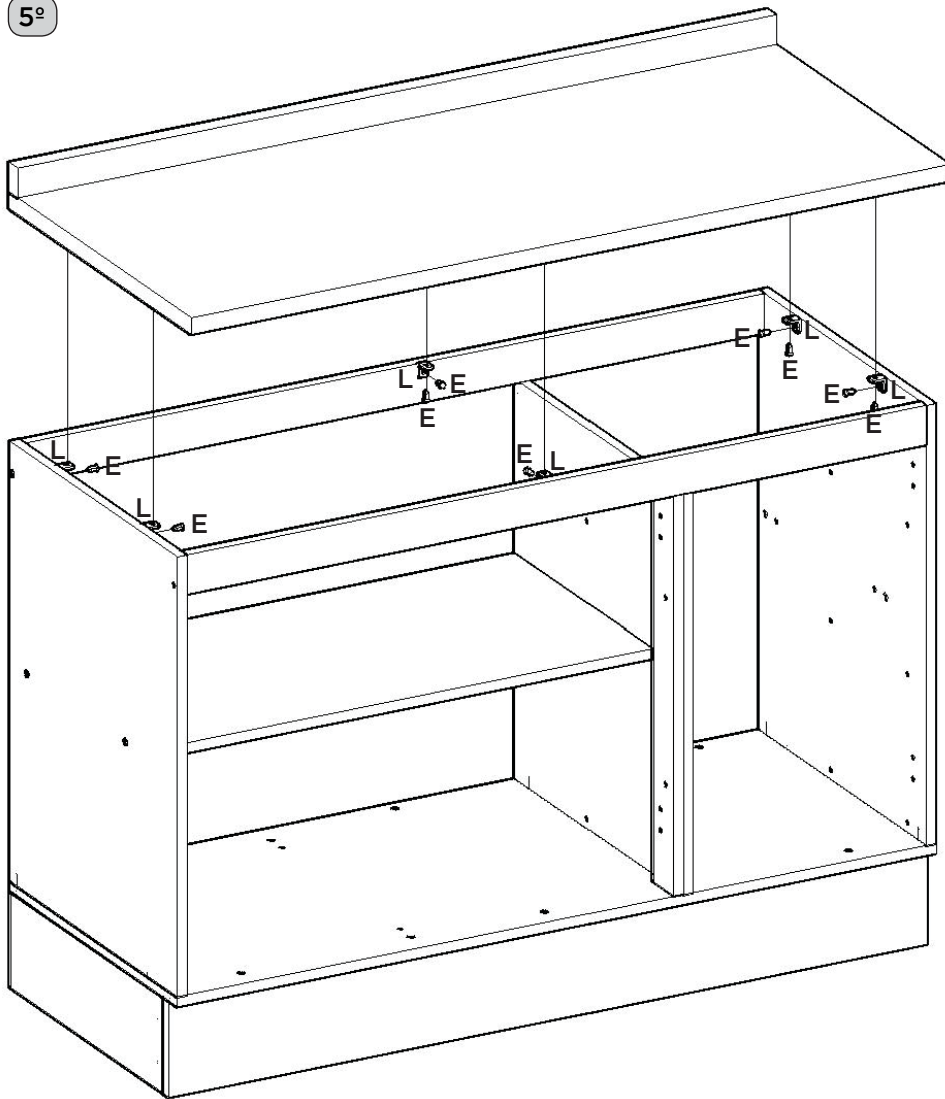

Caso o móvel seja montado com a opção do tampo, fixar o mesmo com 06 cantoneiras (L) e os parafusos 3,5x14mm (E).

Si se monta el auricular con la opción de la cubierta, fijarlo con Los ángulos 06 (L) y 3,5 x14mm tornillos (E).

If the furniture is to be installed with the top cover option, fix it with 06 (L) and 3.5x14mm screws (E).

6°

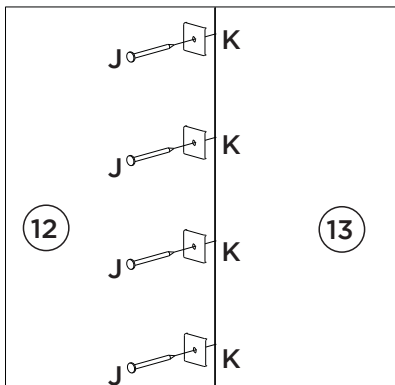
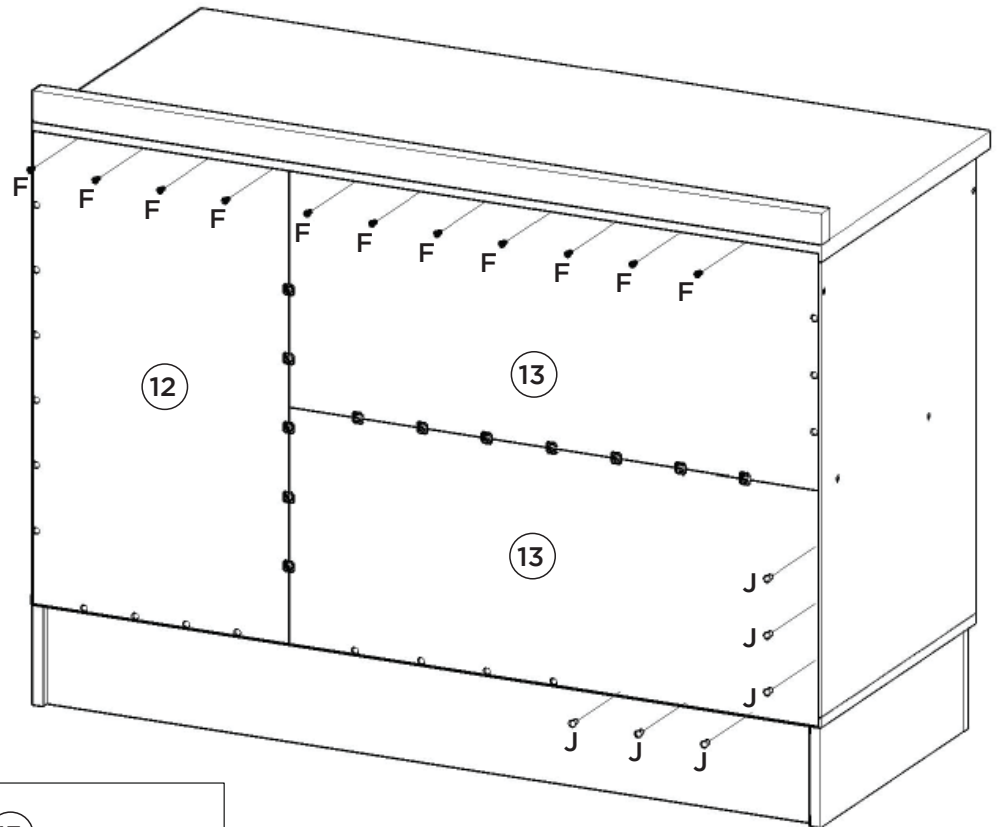

12

13

12

13

13

J

J

J

J

J

J

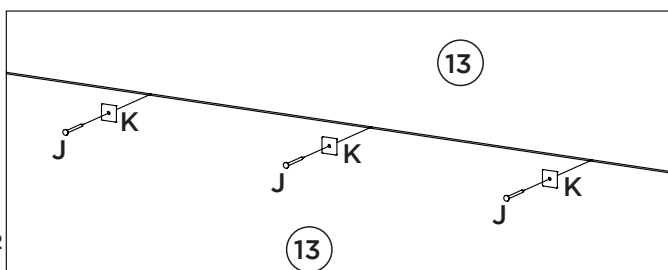

13

13

12

7º

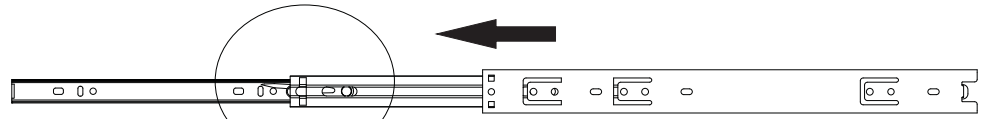
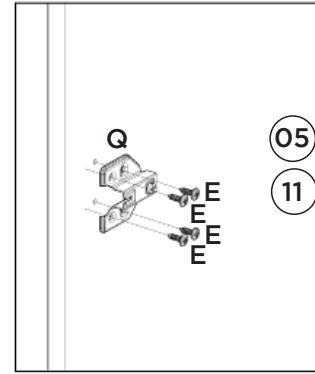
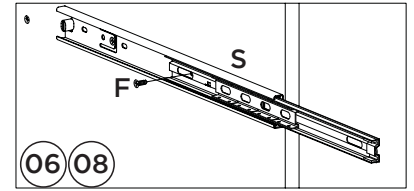
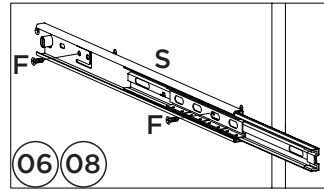
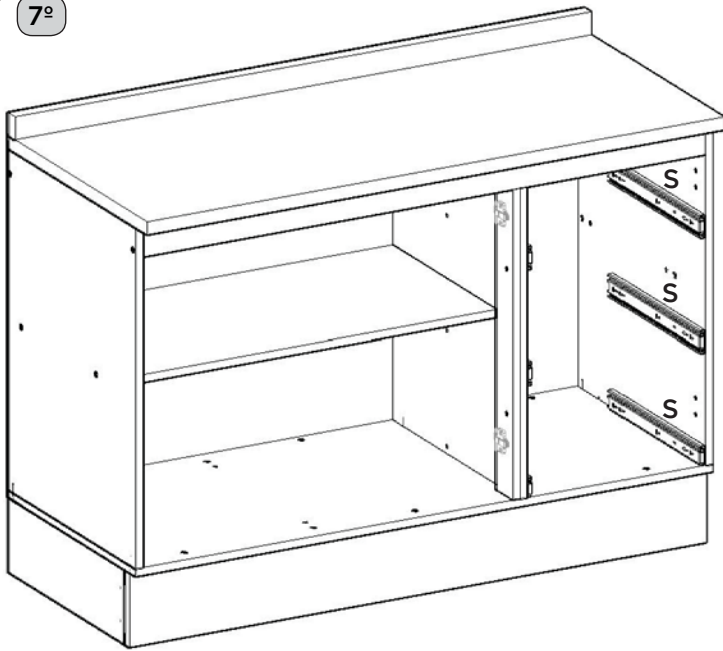

Para a desmontagem da corredeira siga a instrução ao lado.

Para el desmontaje seguimiento de diapositivas la instrucción siguiente a.

For the dismount of the sliding onem follows the instruction aside.

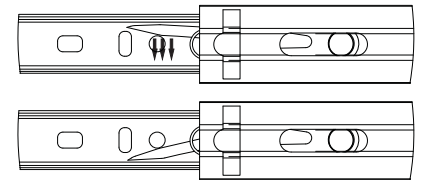

Fixar as corredeiras nessas furações
Fijar las diapositivas de estos agujeros
Fix slides in these drillings

8º

Opção Suspensa

Opción suspendida

Suspended Option

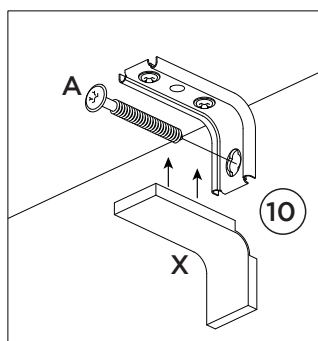
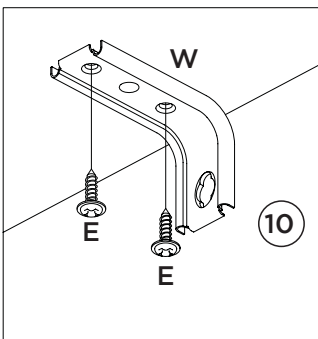

Parede
pared
Wall

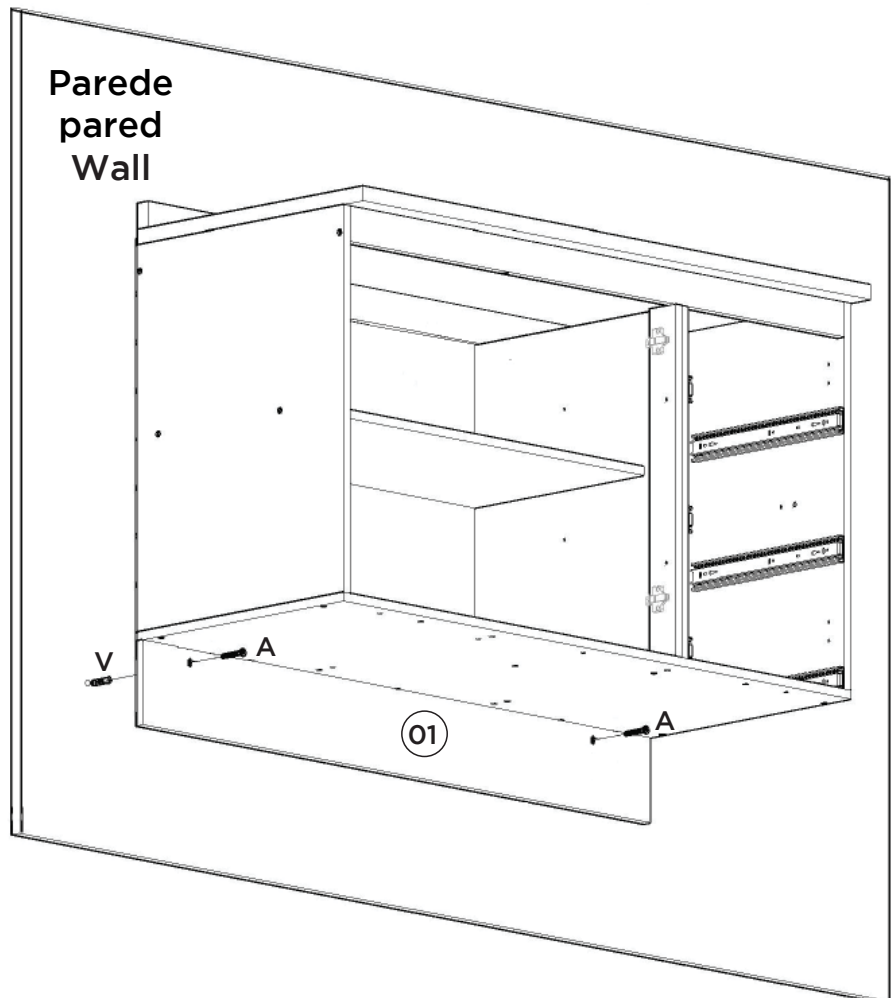

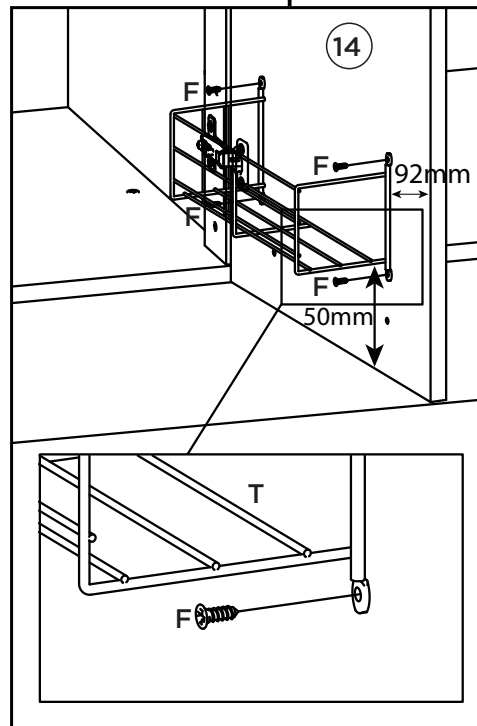
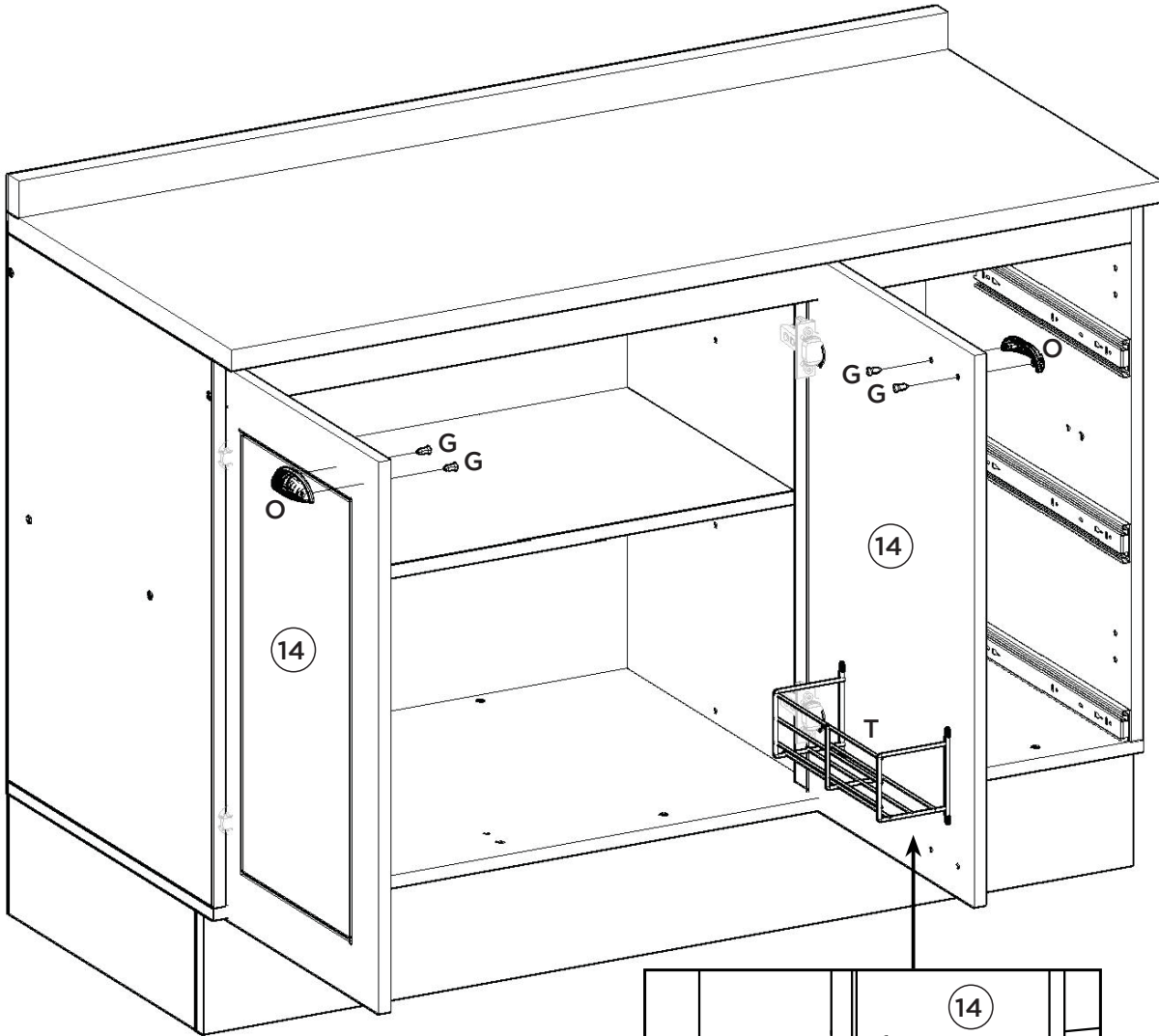
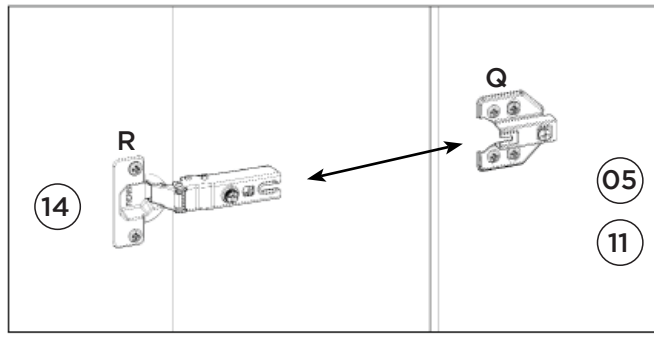
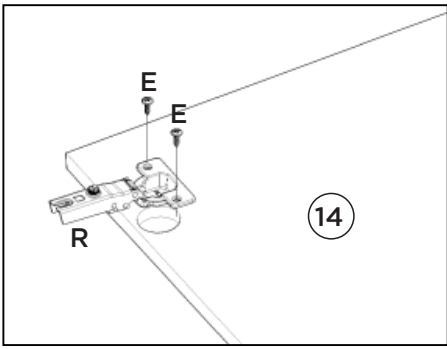

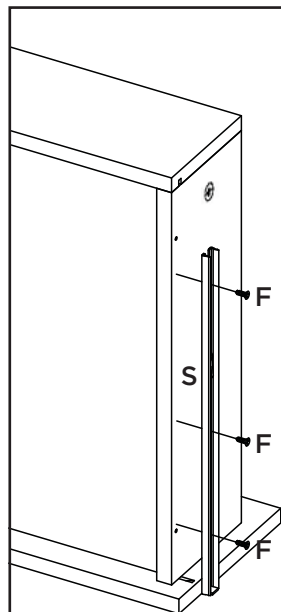
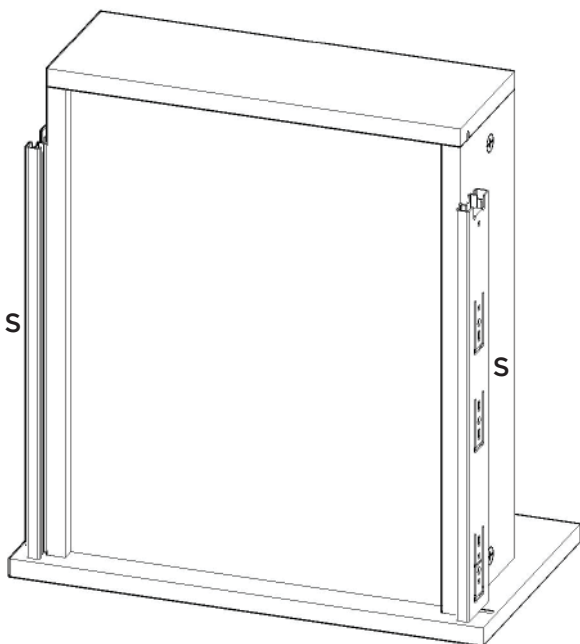
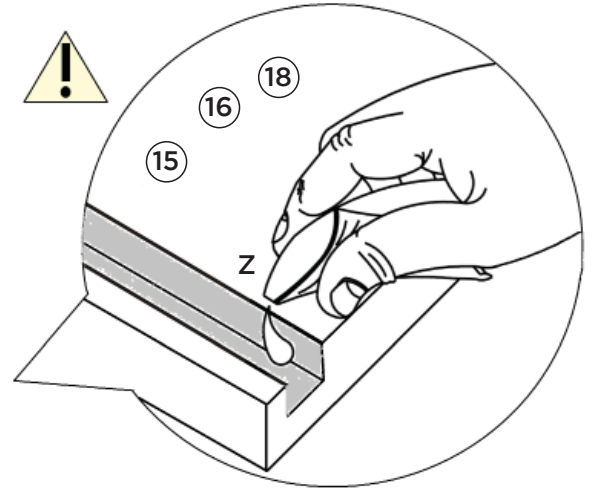
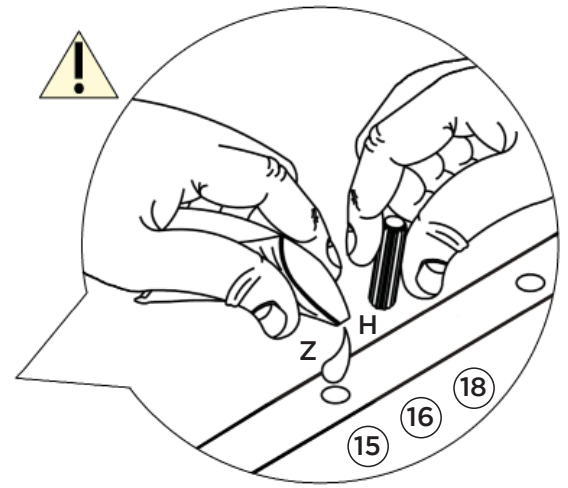
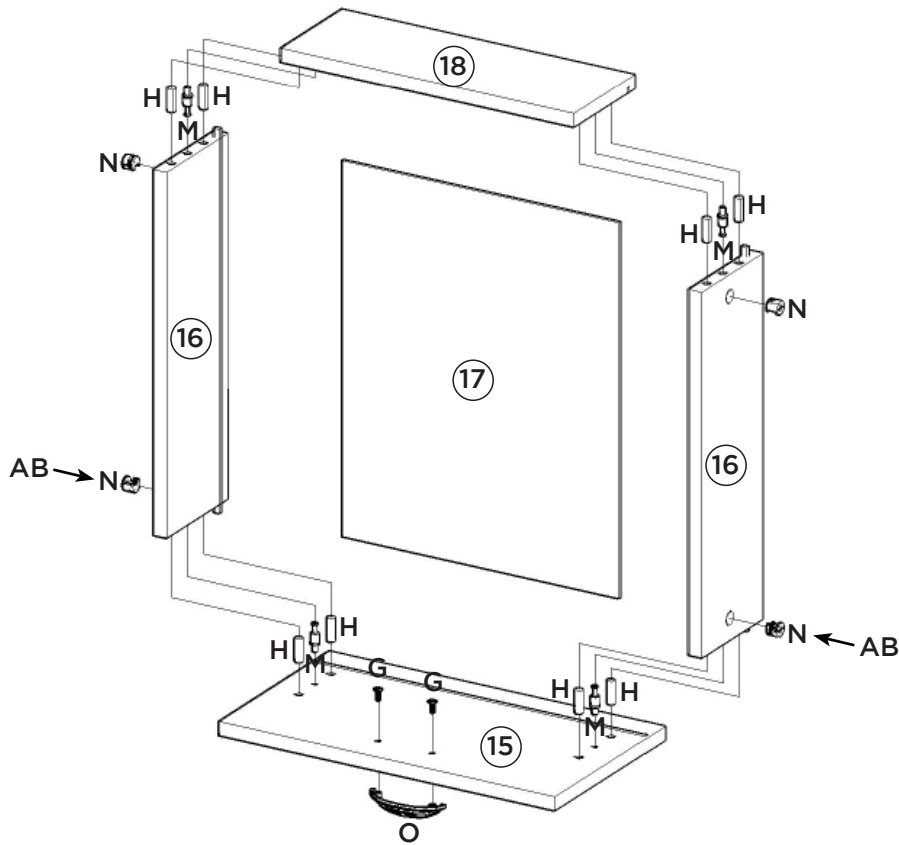

A corredeira (S) deverá ser alinhada com a parte de baixo do lado de gaveta (16).















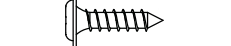
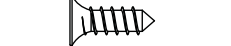







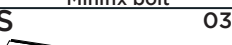

La carcasa (S) será alineada con la parte de por el lado del cajón (16).

The slide (S) should be aligned with the underside of the drawer side (16).

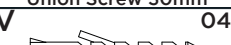
Lista de Peças | Lista de piezas | List of parts

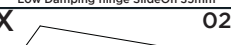
Item	Caixa Caja Box	Qtd Ctd Qty	Descrição Descripción Description	Medidas (mm) Dimensions (mm) Size (measurements) (mm)
01	1/1	01	Rodapé Frontal Frente pie de página Front Footer	1200x145x15
02	1/1	02	Rodapé Lateral Pie de página Side Side Footer	450x145x15
03	1/1	01	Rodapé Traseiro Pie de página trasera Rear Footer	1168x145x15
04	1/1	01	Base Base Base	1200x490x15
05	1/1	01	Lateral esquerda Lateral izquierda Left side	660x490x15
06	1/1	01	Divisão División Division	600x490x15
07	1/1	01	Prateleira Estante Shelf	784x400x15
08	1/1	01	Lateral direita Lateral derecha Right side	660x490x15
09	1/1	01	Travessa frontal Travesaño frontal Front crossbar	1169x60x15
10	1/1	01	Travessa traseira Travesaño trasero Rear bumper	1169x60x15
11	1/1	01	Pilastra da Porta Pilastra Puerta Pilaster door	599x60x15
12	1/1	01	Fundo Lateral Fondo Lateral Lateral Background	683x389x3
13	1/1	02	Fundo Fondo Bottom	803x341x3
14	1/1	02	Porta Puerta Door	665x396x15
15	1/1	03	Frente de gaveta Frente de cajón Front of drawer	396x220x15
16	1/1	06	Lado de Gaveta Lado del cajón Drawer Side	400x122x15
17	1/1	03	Fundo de gaveta Fondo de cajón Bottom of drawer	411x326x3
18	1/1	03	Ripa de trás Malla detrás Rear lath	345x122x15

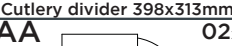
Ferragens | Herrajes | Hardware

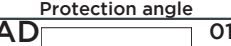
A  Parafuso 5,0x50mm FLA. Tornillo 5,0x50mm FLA. Screw 5,0x50mm FLA.	04x	B  Parafuso 4,5x50mm CHT. Tornillo 4,5x50mm CHT. Screw 4,5x50mm CHT.	04x	C  Parafuso 4,0x25mm CHT. Tornillo 4,0x25mm CHT. Screw 4,0x25mm CHT.	02x	D  Parafuso 3,5x40mm CHT. Tornillo 3,5x40mm CHT. Screw 3,5x40mm CHT.	20x	E  Parafuso 3,5x14mm FLA. Tornillo 3,5x14mm FLA. Screw 3,5x14mm FLA.	50x	F  Parafuso 3,5x12mm CHT. Tornillo 3,5x12mm CHT. Screw 3,5x12mm CHT.	51x
G  Parafuso M4x20mm CHT. ZB Tornillo M4x20mm CHT. ZB Screw M4x20mm CHT. ZB	10x	H  Cavilha 8x25mm Cinta 8x25mm Dowel 8x25mm	52x	I  Prego 12x12mm Anelado Clavo 12x12mm Anillado Ringed Nails 12x12mm	06x	J  Prego 10x10mm Clavo 10x10mm Nail 10x10mm	38x	K  Fixador de fundos Fijador de fondos Bottom fixer	13x	L  Cantoneira plástica Cantonera plástica Plastic angle brackets	11x
M  Parafuso minifix Tornillo minifix Minifix bolt	12x	N  Tambor minifix Tambor minifix Minifix drum	12x	O  Puxador Concha Tirador Concha Shell Handle	05x	P  Parafuso União 30mm Tornillo Unión 30mm Union Screw 30mm	06x	Q  Calço Removível Calzado extraíble Removable Shim	04x	R  Dobradilha SlideOn Baixa Amortecimento 35mm Bisagra SlideOn Baja Amortiguación 35mm Low Damping hinge SlideOn 35mm	04x
S  Corrediça telescópica Diapositivas telescópicas Telescopic slides	03x	T  Porta detergente 256x91mm Puerta detergente 256x91mm Detergent door 256x91mm	01x	U  Divisor talheres 398x313mm Divisor cubiertos 398x313mm Cutlery divider 398x313mm	01x	V  Bucha plástica 8mm Bucha de plástico 8mm 8mm plastic bushing	04x	W  Suporte de fixação Soporte de fijación Mounting bracket	02x	X  Proteção para cantoneira Ángulo de protección Protection angle	02x
Y  Sapata "L" 16x20mm Zapata "L" 16x20mm "L" shoe 16x20mm	06x	Z  Sachê de cola Bolsa de pegamento Glue bag	02x	AA  Giz de correção Tiza de corrección Chalk of correction	02x	AB  Adesivo tapa parafuso 17mm Adhesivo tapón de tornillo 17mm Bolt cover adhesive 17mm	06x	AC  Adesivo tapa parafuso 10mm Adhesivo tapón de tornillo 10mm Bolt cover adhesive 10mm	26x	AD  Etiqueta resinada Henn Etiqueta resinada Henn Henn resin label	01x



O parafuso (P) deve ser usada somente quando este módulo for acoplado a outro módulo componível Henn.

RECOMENDAÇÃO

Para fixar o móvel na parede usar o suporte de fixação (W), o parafuso 3,5x14mm FLA (E), a Bucha 8mm (V) e o parafuso 5,0x50mm FLA (A).



El tornillo (P) se debe utilizar sólo cuando el módulo está conectado a otro módulo componible Henn.

RECOMENDACIÓN

Para conectar el móvil a la pared con el soporte (W), tornillo 3,5 x14mm FLA (E), el casquillo de 8 mm (V) y el 5,0 x50mm tornillo FLA (A).



The screw (P) should be used only when this module is attached to another Henn modular module.

RECOMMENDATION

To fix the furniture to the wall use the mounting bracket (W), the 3.5x14mm FLA (E) screw, the 8mm bushing (V) and the 5.0x50mm FLA screw (A).

INSTRUÇÕES DE MONTAGEM

INSTRUCCIONES DE MONTAJE ASSEMBLY INSTRUCTIONS

C908-114 Calcare

Requisitos para montagem
Requisitor para la montaje
Assembly Requirements

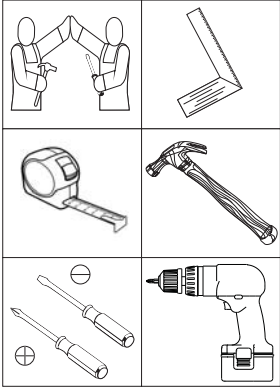

Imagens meramente ilustrativas
Imágenes meramente ilustrativas
Images for illustration only

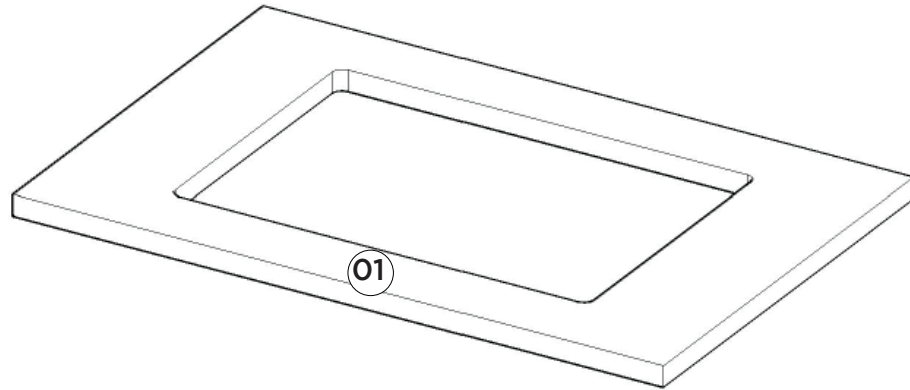

AVISO

Para limpeza de seu móvel, use uma flanela seca ou umedecida, e não utilize produtos químicos que possam danificar seu produto.

SISTEMA DE MONTAGEM

O sistema de montagem dos produtos, funciona de acordo com a ordem crescente dos números indicados no desenho. Ex: 01, 02, 03, 04... até a conclusão da montagem.

ADVERTENCIA

Para limpieza de su móvil, use una flanela seca o húmeda, y no utilice productos químicos que puedan dañar su producto.

SISTEMA DE MONTAJE

El sistema de montaje de los productos funciona de acuerdo con el orden creciente de los números indicados en el dibujo. Ej.: 01, 02, 03, 04... hasta la conclusión del montaje.

NOTICE

To clean your furniture, use a dry or wet cloth, and do not use chemicals that may damage your product.

ASSEMBLY SYSTEM

The products' assembly system works according to the increasing order of the indicated numbers. For example: 01, 02, 03, 04 ... to the end of the assembly.

Lista de Peças | Lista de piezas | List of parts

Item	Caixa Caja Box	Qty Ctd Qty	Descrição Descripción Description	Medidas (mm) Dimensions (mm) Size (measurements) (mm)
01	1/1	01	Tampo Tapa Top	800x533x25

Ferragens | Herrajes | Hardware

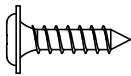
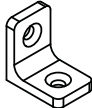
A	08x	B	04x
			
Parafuso 3,5x14mm FLA. Tornillo 3,5x14mm FLA. Screw 3,5x14mm FLA.		Cantoneira plástica Cantonera plástica Plastic angle brackets	

 Estas ferragens constam no Pacote do respectivo Balcão.
Estos herrajes constan en el Paquete del respectivo Balcón.
These hardware are included in the Package of the respective Counter.

1º

Esse tampo é opcional e é vendido separadamente

Esta vez es opcional y se vende por separado

This top is optional and is sold separately

Exemplo de como fixar o Tampo Cooktop no produto.

Ejemplo de cómo fijar el Tablero Cooktop en el producto.

Example of how to secure the Cooktop Top to the product.

