

MONTE O MÓVEL COMO NÓS O PRODUZIMOS: COM CARINHO.

ASSEMBLE THE FURNITURE AS WE PRODUCE IT: WITH LOVE.

MONTE EL MUEBLE COMO NOSOTROS LO PRODUCIMOS: CON CARINO.

Dicas de Conservação / Maintenance Tips / Dicas para Conservación

*Para limpar ou tirar manchas, utilize uma flanela umedecida em solução de água e álcool, na mesma proporção.

*Evite exposição ao sol.

*To clean or remove stains, use a piece of flannel dampened with a water and alcohol solution, in the same proportion.

*Avoid direct sunlight.

*Para limpiar o sacar manchas, utilice una flanela humedecida en solución de agua y alcohol, en la misma proporción.

*Evite la exposición directa al sol.

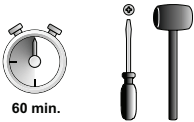
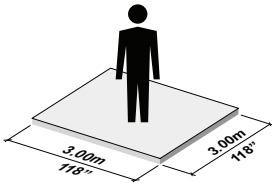

60 min.

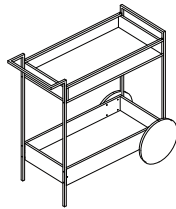

REF.: 27853

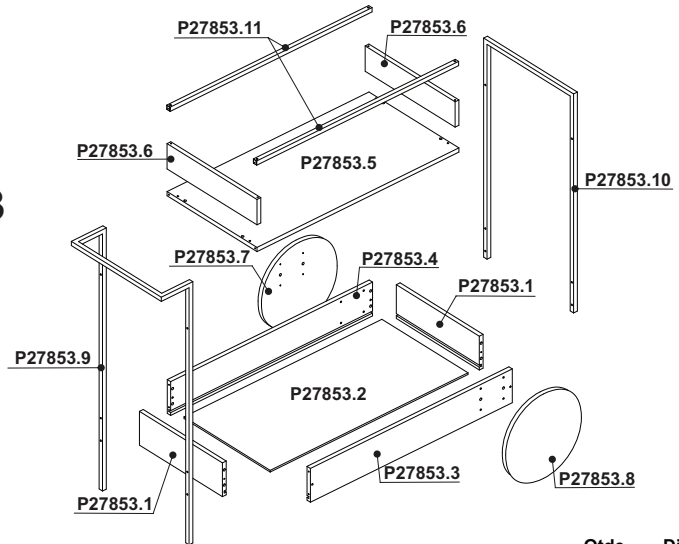

	Denominação / Description / Denominación	Qtde Qty Ctd	Dimensão Dimensión Dimensión
P27853.1	Topo Caixa/Side Box/Lateral Caja	02	369x120x15
P27853.2	Base Caixa/Bottom/Fondo	01	784x383x6
P27853.3	Lateral Caixa Direita/Side Right Box/Lateral Caja Derecha	01	800x120x15
P27853.4	Lateral Caixa Esquerda/Side Left Box/Lateral Caja Izquierda	01	800x120x15
P27853.5	Tampo/Top/Tapa	01	800x400x15
P27853.6	Fechamento/Closure/Cerramiento	02	400x90x15
P27853.7	Roda Esquerda/Left Wheel/Rueda Izquierda	01	301x301x15
P27853.8	Roda Direita/Right Wheel/Rueda Derecha	01	301x301x15
P27853.9	Lateral Metálica c/Puxador/Metallic Side With Handle/Lateral Metálica c/Manija	01	928x400x15
P27853.10	Lateral Metálica/Metallic Side/Lateral Metálica	01	778x400x15
P27853.11	Travessa Metálica/Platter Side/Travesaño Metálico	02	800x15x15

Rev. 00 - 22/05/2020

01

FERRAGENS / HARDWARE LIST / LISTA DE MATERIALES

A		4,5x45mm	24
B		4,5x25mm	08
C		8x30mm	12
D		8x20mm	04
E			02

ETAPA DE PREPARAÇÃO DAS PEÇAS. STAGE OF PREPARATION OF THE PIECES. FASE DE PREPARACIÓN DE LAS PIEZAS.

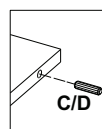
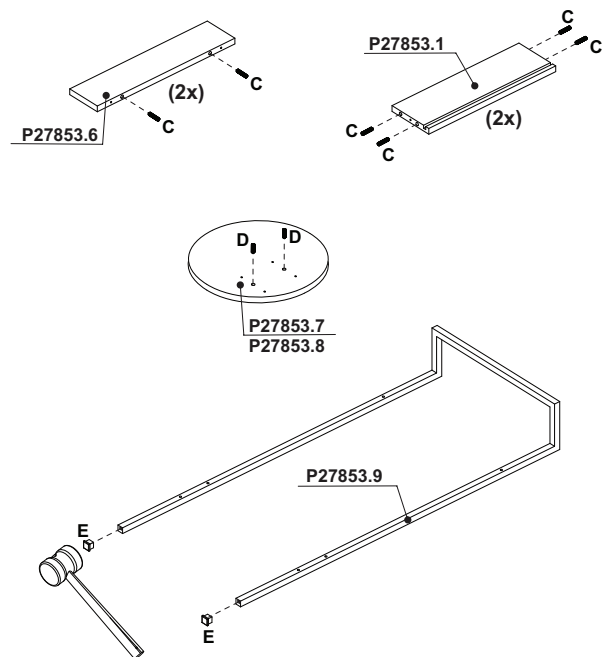

detalhe 1

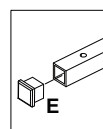

detalhe 2

02

1 Passo
Step
Paso

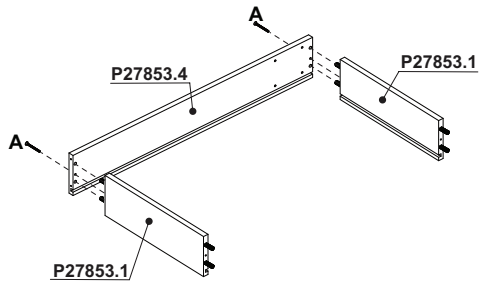

2 Passo
Step
Paso

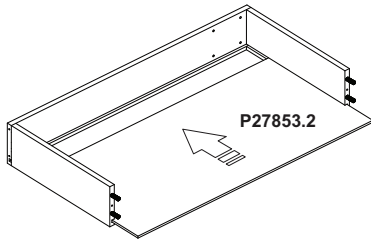

3 Passo
Step
Paso

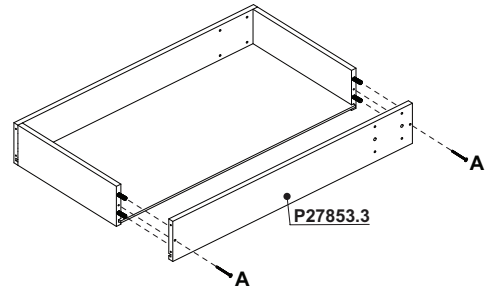

4 Passo
Step
Paso

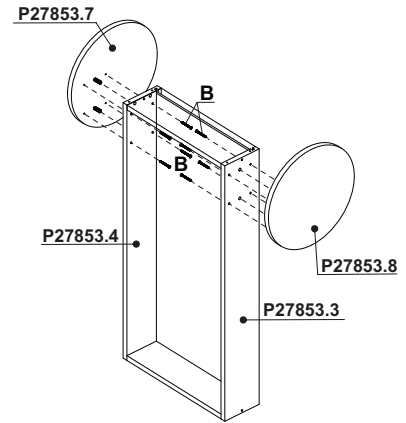

5 Passo
Step
Paso

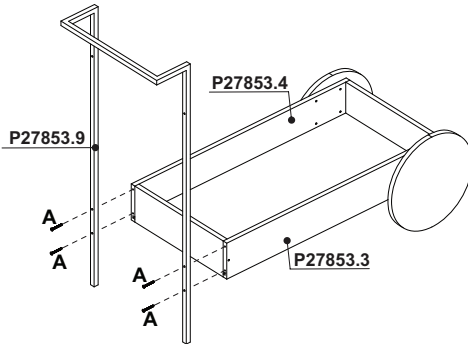

6 Passo
Step
Paso

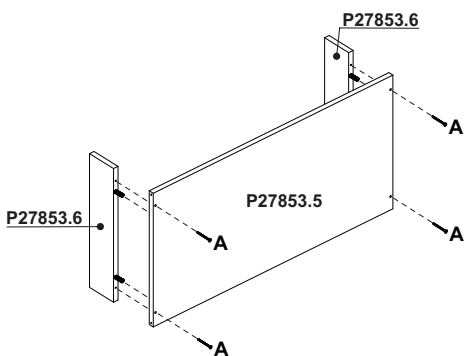

7 Passo
Step
Paso

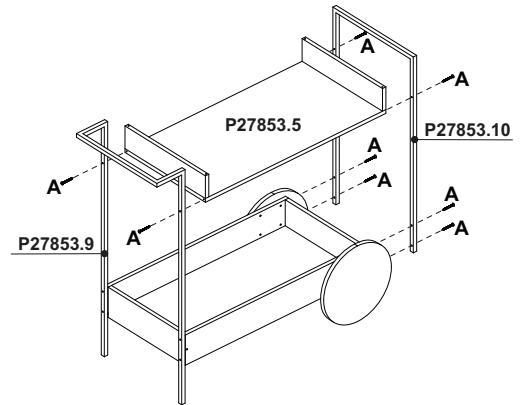

8 Passo
Step
Paso

