

### REF.: 27872

**MONTE O MÓVEL COMO NÓS O PRODUZIMOS:  
COM CARINHO**  
**ASSEMBLE THE FURNITURE AS WE PRODUCE  
IT: WITH LOVE**  
**MONTE EL MUEBLE COMO NOSOTROS LO  
PRODUCIMOS: CON CARIÑO**

#### Dicas de Conservação:

\*Para limpar ou tirar manchas, utilize uma flanela umedecida em solução de água e álcool, na mesma proporção.

\*Evite exposição ao sol.

#### Maintenance Tips:

\*To clean or remove stains, use a piece of flannel dampened with a water and alcohol solution, in the same proportion.

\*Avoid direct sunlight.

#### Dicas para Conservación:

\*Para limpiar o sacar manchas, utilice una flanela humedecida en solución de agua y alcohol, en la misma proporción.

\*Evite la exposición directa al sol.

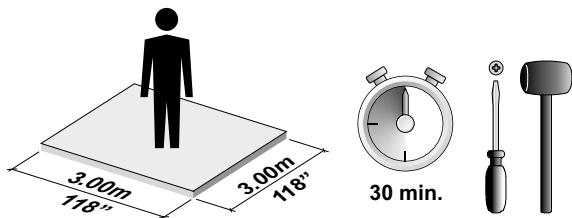

**CARGA MÁXIMA SUPTADA**  
**MAXIMUM WEIGHT SUPPORTED**  
**PESO MAXIMO SOPORTADO**



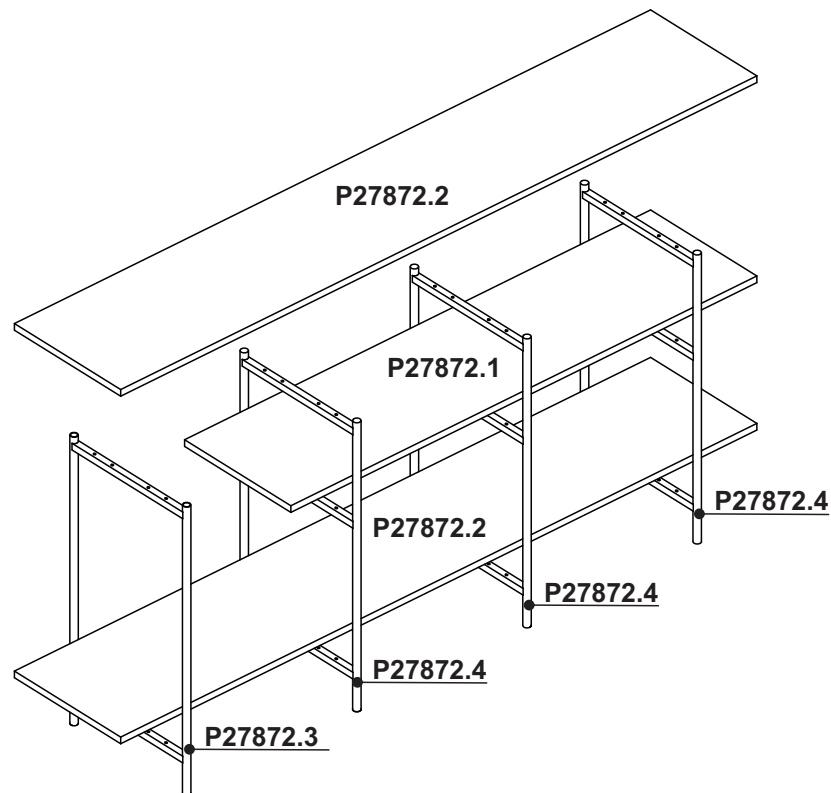
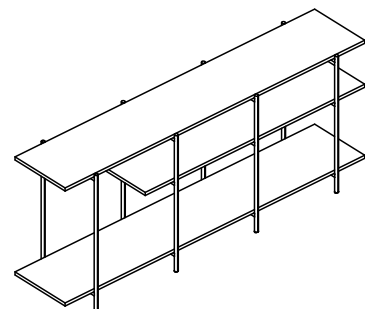
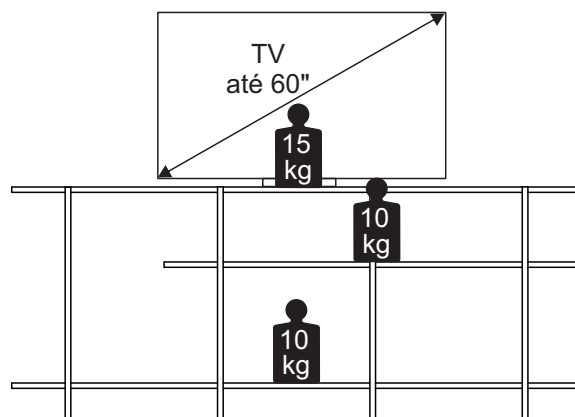

**35Kg**



	Denominação / Description / Denominación	Qtde Qty Ctd	Dimensão Dimension Dimensión
P27872	P27872.1 Prateleira/Shelf/Repisa	01	1172x300x15
	P27872.2 Base-Tampo/Base-Top/Base-Tapa	02	1600x300x15
	P27872.3 Lateral Metálica/Metallic Side/Lateral Metálica	01	650x334x16
	P27872.4 Lateral Metálica/Metallic Side/Lateral Metálica	03	650x334x16

# FERRAGENS / HARDWARE LIST / LISTA DE MATERIALES

<b>A</b>		<b>08</b>
<b>B</b>		<b>44</b>

4,5x25mm



**ATENÇÃO:** Aperte os parafusos somente até travar, utilizando a chave Philips, nunca use parafusadeira neste produto. Cuidado ao apertar parafusos, o trabalho deve ser feito com precisão, para evitar que o parafuso espante ou o produto estrague.

**ATTENTION:** Tighten the screws only until it locks, using a Philips screwdriver, never use a screwdriver on this product.

Be careful when tightening screws, the work must be done accurately, to prevent the screw from dusting or the product from spoiling.

**ATENCIÓN:** Apriete los tornillos solo hasta que se bloquee, con un destornillador Philips, nunca use un destornillador en este producto.

Tenga cuidado al apretar los tornillos, el trabajo debe hacerse con precisión, para evitar que el tornillo se empolve o que el producto se estropee.

## ETAPA DE PREPARAÇÃO DAS PEÇAS. STAGE OF PREPARATION OF THE PIECES. FASE DE PREPARACIÓN DE LAS PIEZAS.

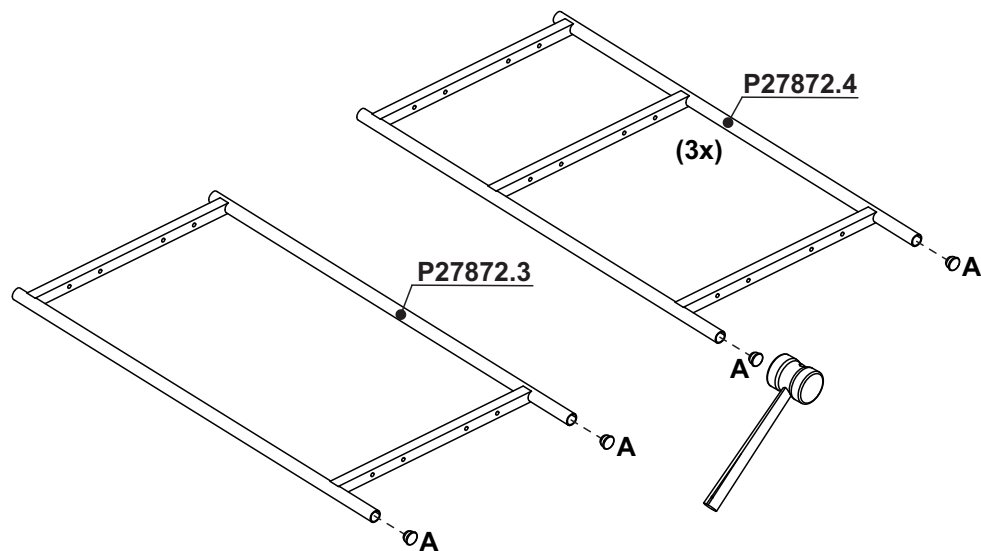

### 1 Passo Step Paso

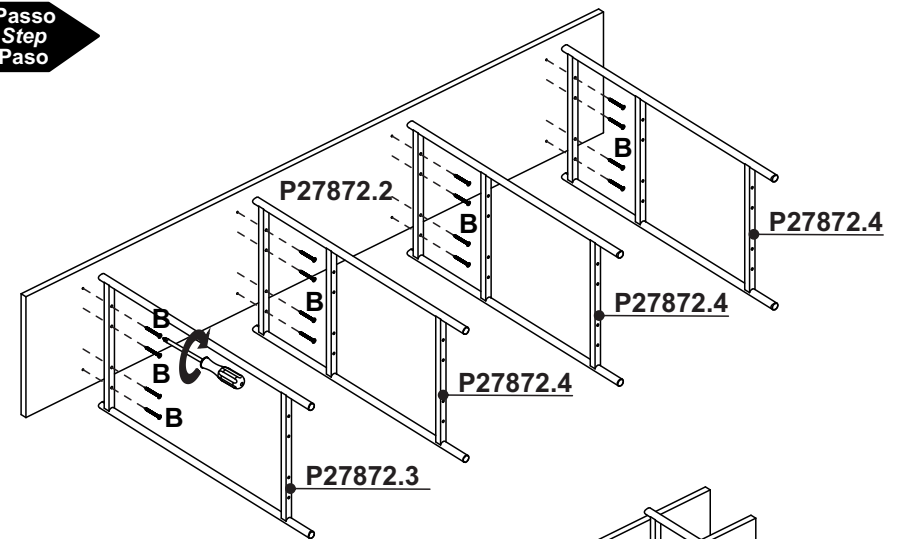

### 2 Passo Step Paso

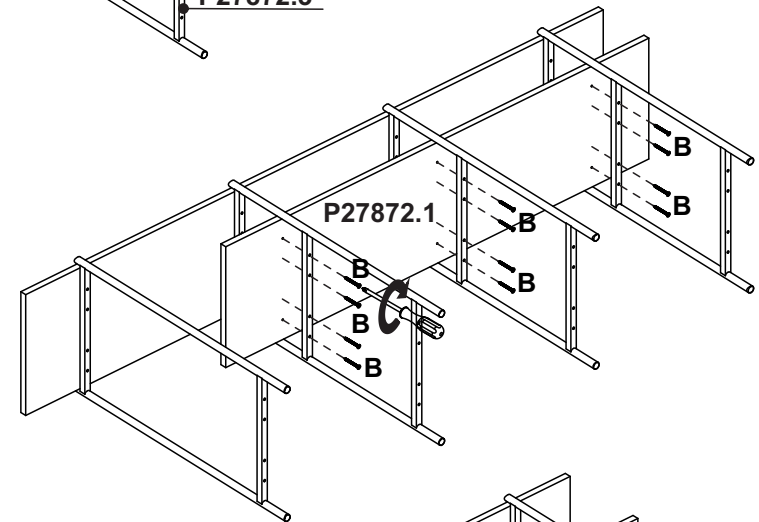

### 3 Passo Step Paso

