

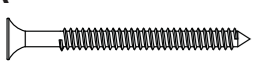

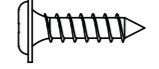

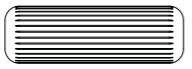

Item	Caixa Caja Box	Qtd Ctd Qty	Descrição Descripción Description	Medidas (mm) Dimensions (mm) Size (measurements) (mm)
01	1/1	01	Base Base Base	650x430x15
02	1/1	01	Lateral esquerda Lateral izquierda Left side	490x440x15
03	1/1	01	Fundo Fondo Bottom	650x475x15
04	1/1	01	Frente Baú Frente al Baú Front chest	650x360x15
05	1/1	01	Lateral direita Lateral derecha Right side	490x440x15
06	1/1	01	Porta Basculante Puerta basculante Swing door	644x450x15

Ferragens | Herrajes | Hardware

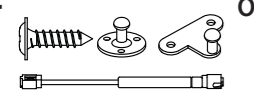
A	14x	B	20x	C	12x	D	02x	E	02x
									
Parafuso 3,5x40mm CHT. Tornillo 3,5x40mm CHT. Screw 3,5x40mm CHT.		Parafuso 3,5x14mm FLA. Tornillo 3,5x14mm FLA. Screw 3,5x14mm FLA.		Cavilha 8x25mm Cinta 8x25mm Dowel 8x25mm		Calço metal 12mm Calzado metálico 12mm 12mm metal shim		Dobradiça metal 26mm Bisagra de metal 26mm 26 mm metal hinge	
F	01x	G	02x	H	02x	I	02x	J	18x
									
Kit Pistão a gás 60N Kit Pistón de gas 60N 60N Gas Piston Kit		Rodízio Preto RD50 c/ trava Rueda negra RD50 c/ traba Black caster RD50 with latch		Rodízio Preto RD50 s/ trava Rueda negra RD50 s/ traba Black caster RD50 No latch		Batente PVC para Porta Parada de PVC para Puerta PVC Door Stop		Adesivo tapa parafuso 10mm Adhesivo tapón de tornillo 10mm Bolt cover adhesive 10mm	
K	04x	L	01x						
									
Parafuso União 15mm Tornillo Unión 15mm Screw union 15mm		Etiqueta resinada Henn Etiqueta resinada Henn Henn resin label							

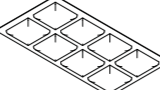
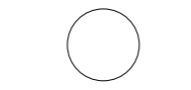
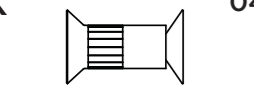

Ind. e Com. de Móveis Henn
Mondai - SC - Brasil

+55 49 3674.3500

@moveishenn
www.henn.com.br

INSTRUÇÕES DE MONTAGEM

INSTRUCCIONES DE MONTAJE
ASSEMBLY INSTRUCTIONS

Baú Aquarela
1717-10 Branco

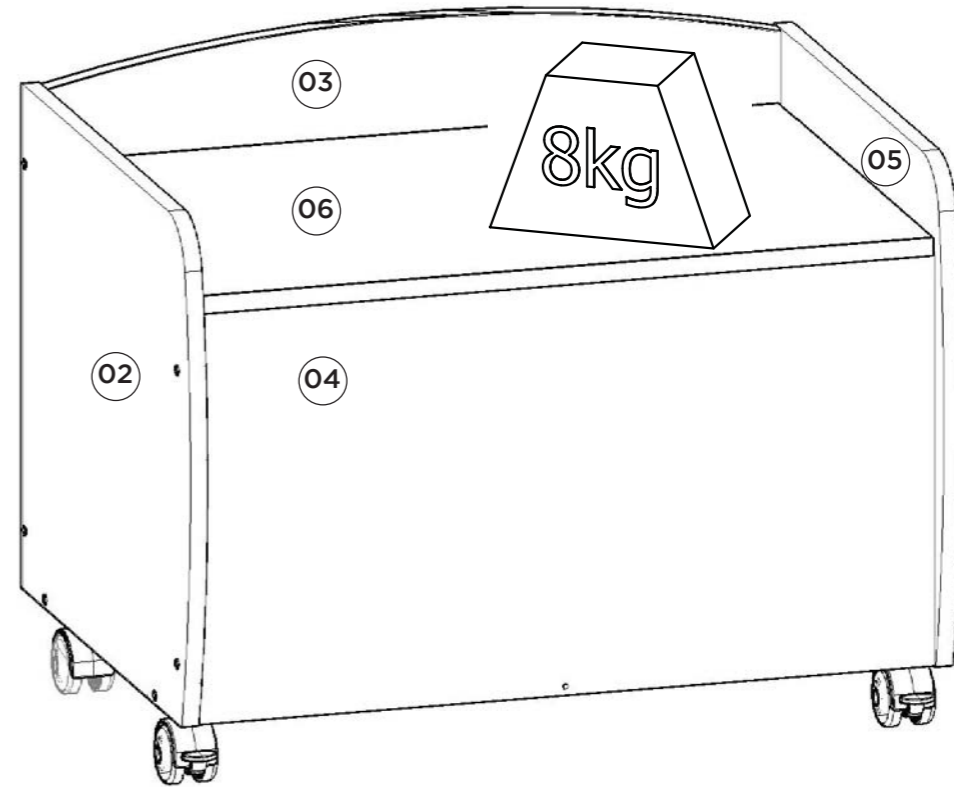

Pesos máximos recomendados com carga distribuída
Peso máximo recomendado con la carga distribuida
Recommended maximum weights with evenly distributed.

Requisitos para montagem
Requisitor para la montaje
Assembly Requirements

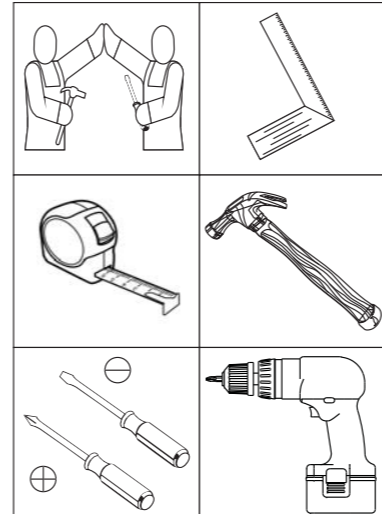

Imagens meramente ilustrativas
Imágenes meramente ilustrativas
Images for illustration only

AVISO

Para limpeza de seu móvel, use uma flanela seca ou umedecida, e não utilize produtos químicos que possam danificar seu produto.

SISTEMA DE MONTAGEM

O sistema de montagem dos produtos, funciona de acordo com a ordem crescente dos números indicados no desenho. Ex: 01, 02, 03, 04... até a conclusão da montagem.

ADVERTENCIA

Para limpieza de su móvil, use una flanela seca o húmeda, y no utilice productos químicos que puedan dañar su producto.

SISTEMA DE MONTAJE

El sistema de montaje de los productos funciona de acuerdo con el orden creciente de los números indicados en el dibujo. Ej.: 01, 02, 03, 04... hasta la conclusión del montaje.

NOTICE

To clean your furniture, use a dry or wet cloth, and do not use chemicals that may damage your product.

ASSEMBLY SYSTEM

The products' assembly system works according to the increasing order of the indicated numbers. For example: 01, 02, 03, 04 ... to the end of the assembly.

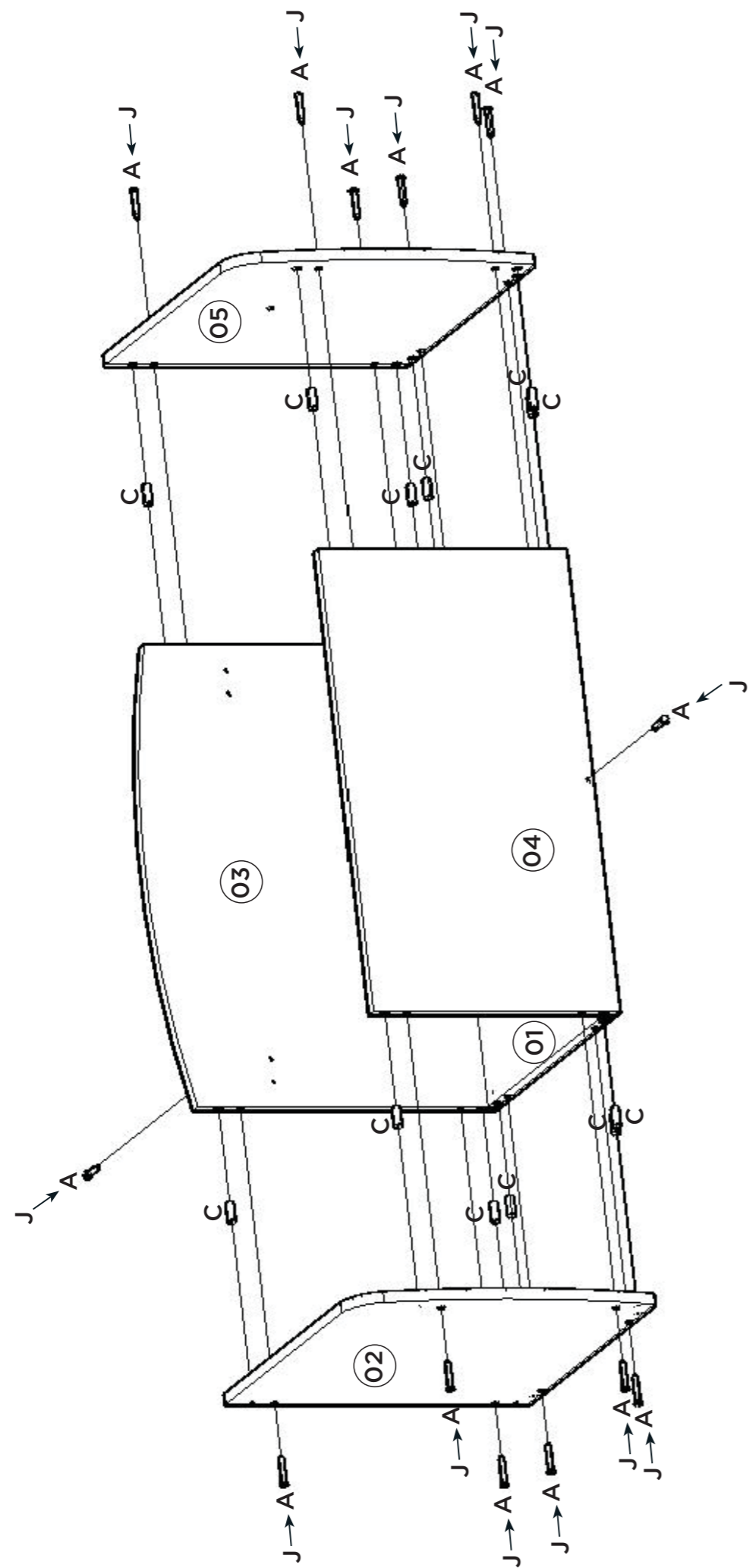

Vista Inferior da Base (01)
colocação dos Rodízios

Vista Inferior de la Base (01)
colocación de las ruedas

Bottom View of Base (01)
placement of Castors

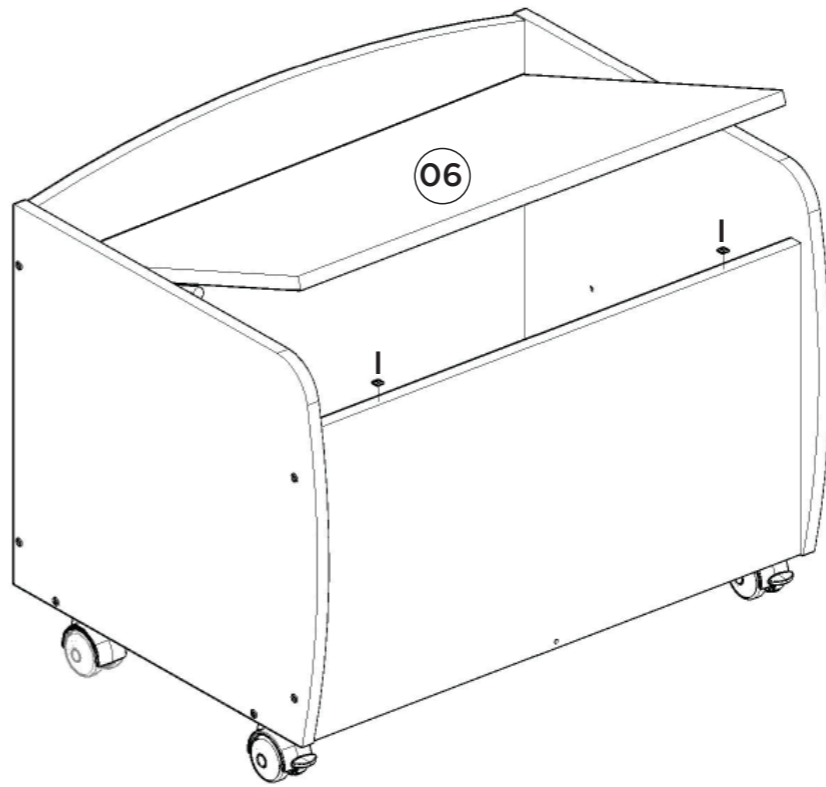
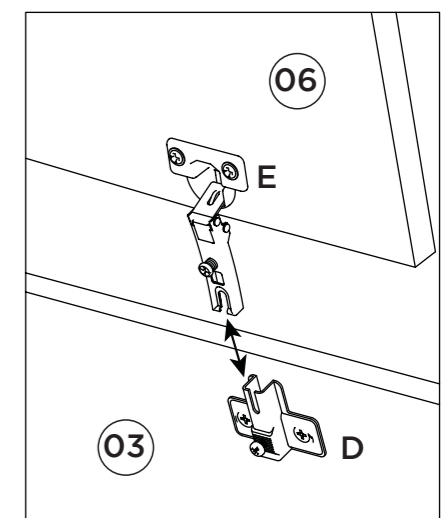
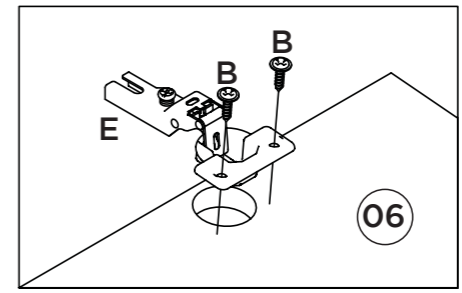
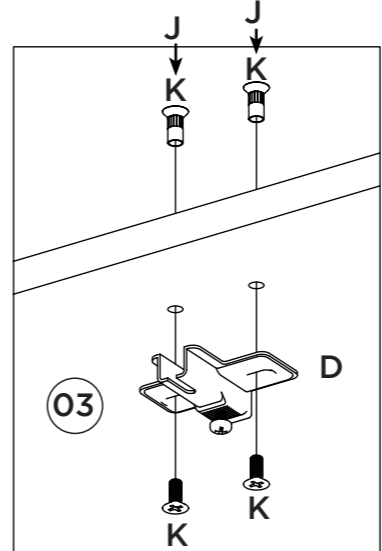
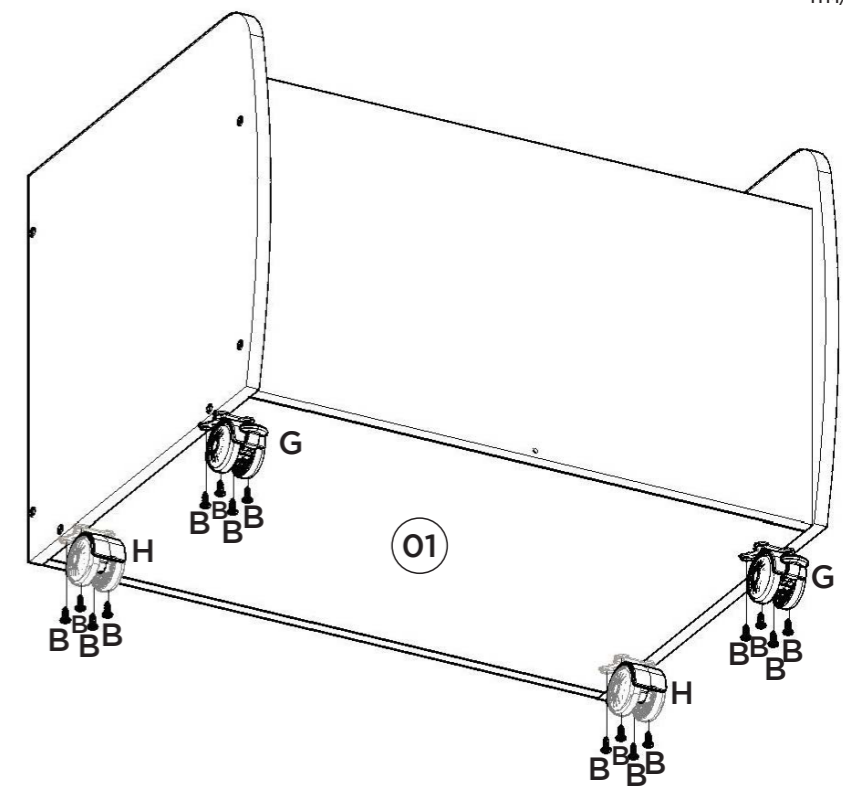

Colocação do Kit Pistão 60N

Colocación del kit de pistón 60N

Placement of Piston Kit 60N

