

MANUAL DE MONTAGEM

INSTRUCCIONES DE MONTAJE

ASSEMBLY INSTRUCTIONS

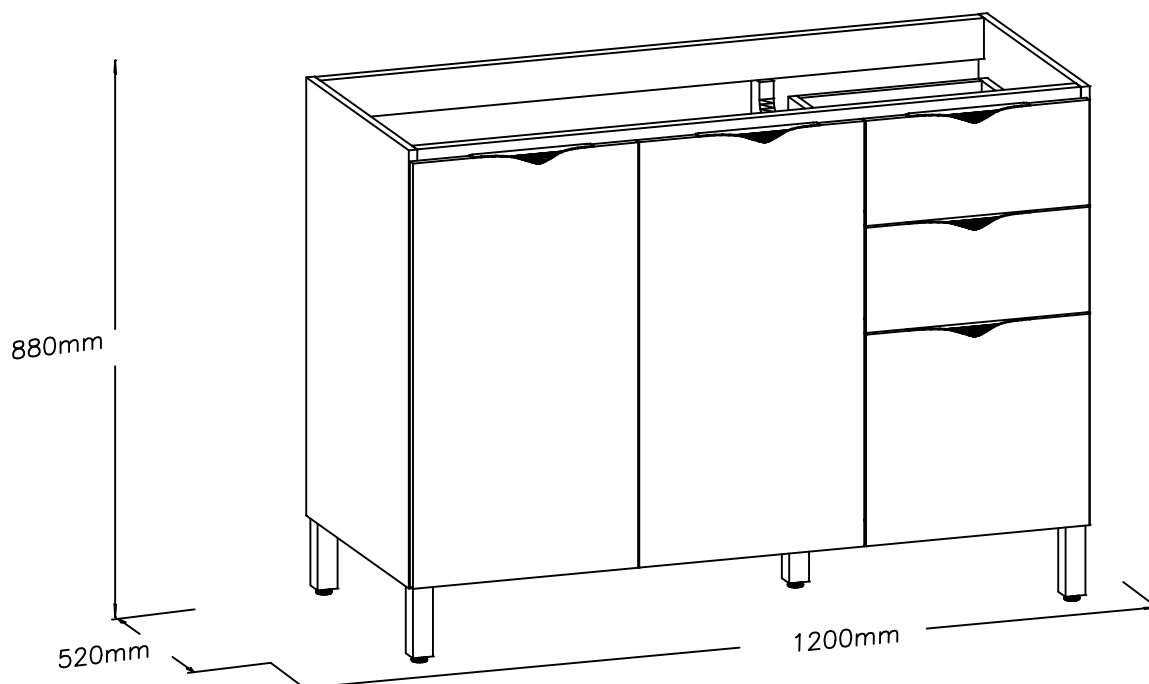
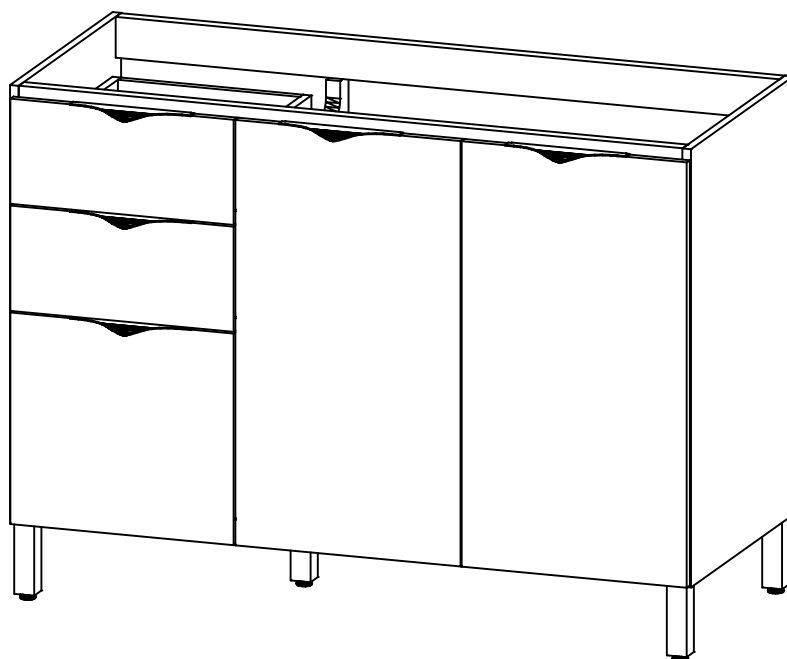

ATENÇÃO / PRECAUCIÓN / ATTENTION:

- 1 – Ler atentamente todo o manual antes de iniciar a montagem do móvel.
- 2 – A montagem deve ser feita em uma superfície plana e limpa.
- 3 – Recomenda-se utilizar a embalagem do móvel para forrar e chão e assim não danificá-lo.
 - 1 – Lea cuidadosamente todo el manual antes de comenzar el montaje.
 - 2 – La instalación debe hacerse sobre una superficie plana y limpia.
 - 3 – Recomanda ser utilizado para empaquetar móvel a la línea y tierra y por lo tanto dañar ellos.
- 1 – Read the entire manual carefully before starting the furniture assembly.
- 2 – The assembly must be done on a flat and clean surface.
- 3 – It is recommended to use the packaging of the furniture to cover and floor and thus not to damage them.

LIMPEZA E CONSERVAÇÃO / LIMPIEZA Y CONSERVACIÓN / CLEANLINESS AND CONSERVATION:

A limpeza do móvel deve ser feita com utilização de pano umedecido com água, podendo conter uma pequena quantidade de álcool. Não utilize produtos abrasivos.

La unidad de limpieza se debe realizar con el uso de paño humedecido con agua y puede contener una pequeña cantidad de alcohol. No utilice productos abrasivos.

The furniture should be cleaned with a cloth dampened with water and may contain a small amount of alcohol. Do not use abrasive products.

GARANTIA / GARANTÍA / WARRANTY:

90 dias para defeitos de fabricação.

90 días a defectos de fabricación.

90 days for manufacturing defects.

FERRAMENTAS NECESSÁRIAS / HERRAMIENTAS NECESARIAS / TOOLS REQUIRED:

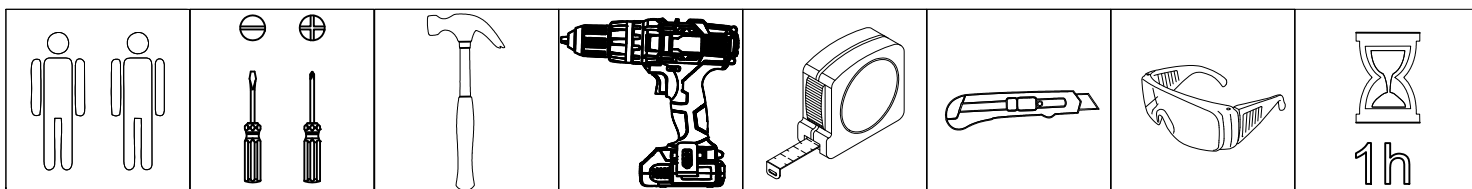

Acesse as dicas de
montagem no Youtube

Accede a los consejos de
montaje en Youtube.

Access the mounting tips on
Youtube.









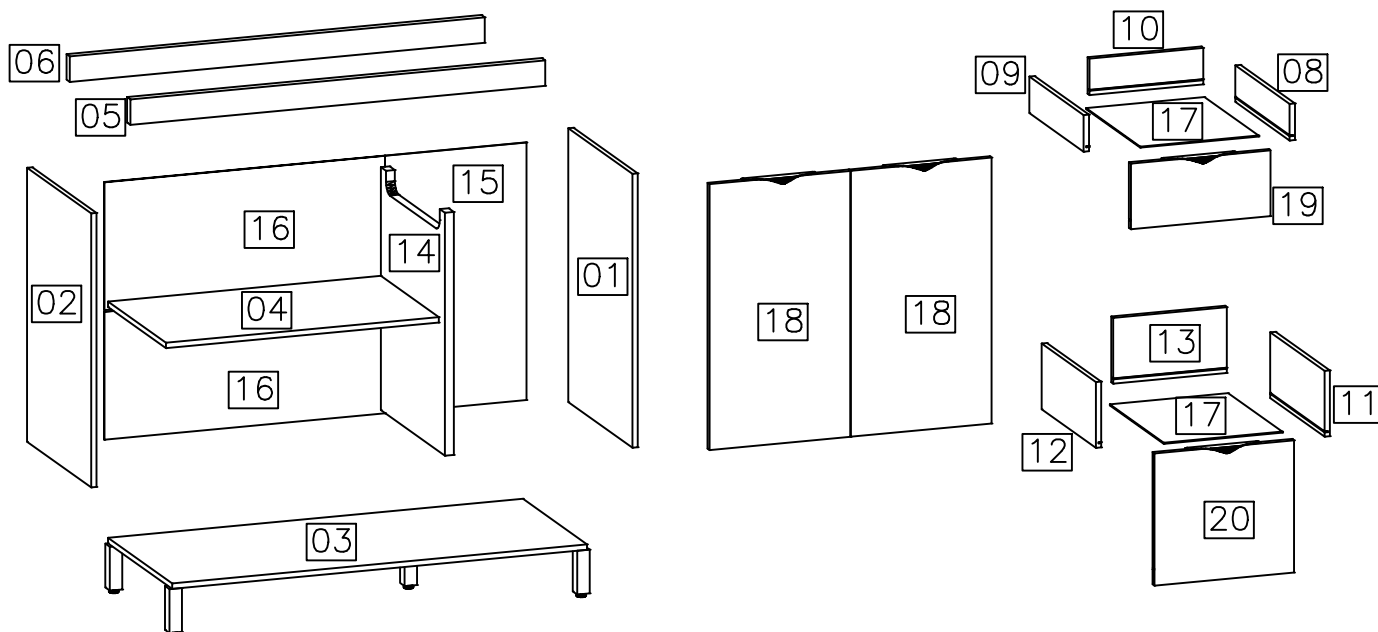

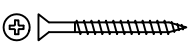

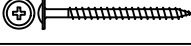
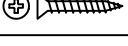

www.youtube.com/MoveisKappesberg

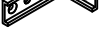
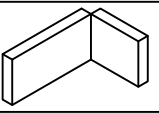
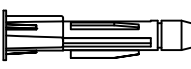
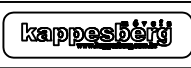



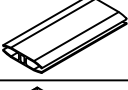

Lista de peças / Lista de piezas / List of pieces

Código/ Código/ Code	Descrição	Descripción	Description	Quantidade/ Cantidad/ Amount	Comprimento/ Longitud/ Length (mm)	Largura/ Ancho/ Width (mm)	Espessura/ Espesor/ Thickness (mm)	Caixa/ Caja/ Box
01	Lateral direita	Lateral derecha	Right side	1	750	496	15	A
02	Lateral esquerda	Lateral izquierda	Left side	1	750	496	15	A
03	Base	Pieza de suelo	Base	1	1168	496	15	A
04	Prateleira	Estanterías	Shelf	1	768	448	15	A
05	Travessa frontal	Travesaño delantero	Front cross-piece	1	1168	70	25	A
06	Travessa traseira	Travesaño trasero	Cross-back piece	1	1168	70	25	A
07	Sarrafo de apoio	Marco de apoyo	Support slat	1	1188	50	15	A
08	Lateral de gaveta dir.	Lateral de cajón izquierda	Right drawer side	2	420	100	15	A
09	Lateral de gaveta esq.	Lateral de cajón derecha	Left drawer side	2	420	100	15	A
10	Cabeceira de gaveta	Cabecera de cajón	Back drawer	2	320	100	15	A
11	Lateral direita do gavetão	Lateral de cajón derecha	Right drawer side	1	420	180	15	A
12	Lateral esquerda do gavetão	Lateral de cajón izquierda	Left drawer side	1	420	180	15	A
13	Cabeceira de gavetão	Cabecera de cajón mayor	Largest drawer headboard	1	320	180	15	A
14	Divisória	División	Division	1	665	496	25	A
15	Costas das gavetas	Piezas de fondo de los cajones	Bottom parts of the drawers	1	705	400	3	A
16	Costas	Pieza del fondo	Back panel	2	790	350	3	A
17	Fundo de gaveta	Fondo de cajón	Bottom drawer	3	418	333	3	A
18	Portas	Puertas	Doors	2	728	396	15	A
19	Frente de gaveta	Frente de cajón	Front drawer	2	393	180	15	A
20	Frente do gavetão	Frente de cajón mayor	Largest drawer front	1	393	362	15	A

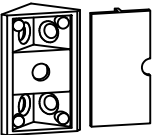
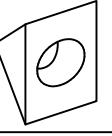

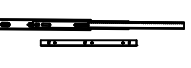
Ferragem / Herrajes / Hardware			
	Código/ Código/ Code	Descrição / Descripción / Description	Quan. / Cant. / Amou.
A	226	 Parafuso/ Tornillo/ Screw 4x40	20
B	4214	 Parafuso/ Tornillo/ Screw 3,5x14	82
C	50311	 Parafuso/ Tornillo/ Screw 5,0x65	6
D	491	 Parafuso/ Tornillo/ Screw 4x25	4
E	25827	 Parafuso/ Tornillo/ Screw 3,5x14 ZB	10
F	5256	 Parafuso/ Tornillo/ Screw 4x20	6
G	107	 Prego/Clava/Nail 10x10	35
I	1802	 Cavilha/Tarugo/Peg 6x30mm	32
J	17024	 Suporte aéreo zb/Suporte de seguridad/Safety bracket	3
K	6959	 Capa para suporte branca/Cubierta de soporte/Support cover	3
L	529	 Bucha invasa/Adapter sleeve/ Manga del adaptador	6
M	58	 Etiqueta marca/Tag label "Kappesberg"	1
N	51433	 Pézinho apolo/Perrito/Foot counter Champagne	5
P	53010	 Puxador de chapa nox/Asar/Handle Champagne	5
Q	FRW= 51255 (Freijo)	 Tapa furo/Tapa del agujero/Tap hole 13mm	27
R	7787	 Dobradiça reta/Bisagra/Hinge 35mm	4
S	7787	 Calço para dobradiça/Calso/Shi m	4
T	7787	 Parafuso da dobradiça/ Tornillo del bisagra/Hinge screw 4,0x14	16
V	FRW= 26076 (Carvalle)	 Perfil H/Perfil de acabado/Finishing profile 770mm	1
Z	40534	 Silicone/Silicona/ Selecone 10x10	8

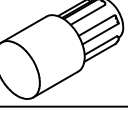
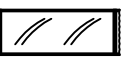
AA	FRW= 52589 (Freijo)		Cantoneira plástica com capa/Cantoneira plástica con tapa/Plastic ledge with cover	6
AB	18458		Suporte triangular preto/Suporte triangular negro/Black triangular support	6
AC	1423		Fixador de costa/Fijador de costa/Shore Fixer	7
AD	38305		Trilho telescópico mini light/Corredera de metal/Metal slide 400mm	3
AE	85		"L" de metal/Cantón "L" de metal/Metal angle bracket "L"	6
AF	8578		"L" de Zamaq/Cantón "L" /angle bracket "L"	2
AH	118		Suporte para prateleira/Suporte de estante/Shelf support	6
AJ	41		Cola branca em bisnaga/Cola blanca/White glue (10g)	1
01 Saco médio para acessórios				
01 Saco médio para puxadores				





-USO OBRIGATÓRIO DA CANTONEIRA DE METAL "AI" NAS TRAVESSAS
-USO MANDATORIO DEL CANTÓN DE METAL "AI" EN LOS SLEEPERS
-MANDATORY USE OF THE ANGLE METAL "AI" IN THE SLEEPERS

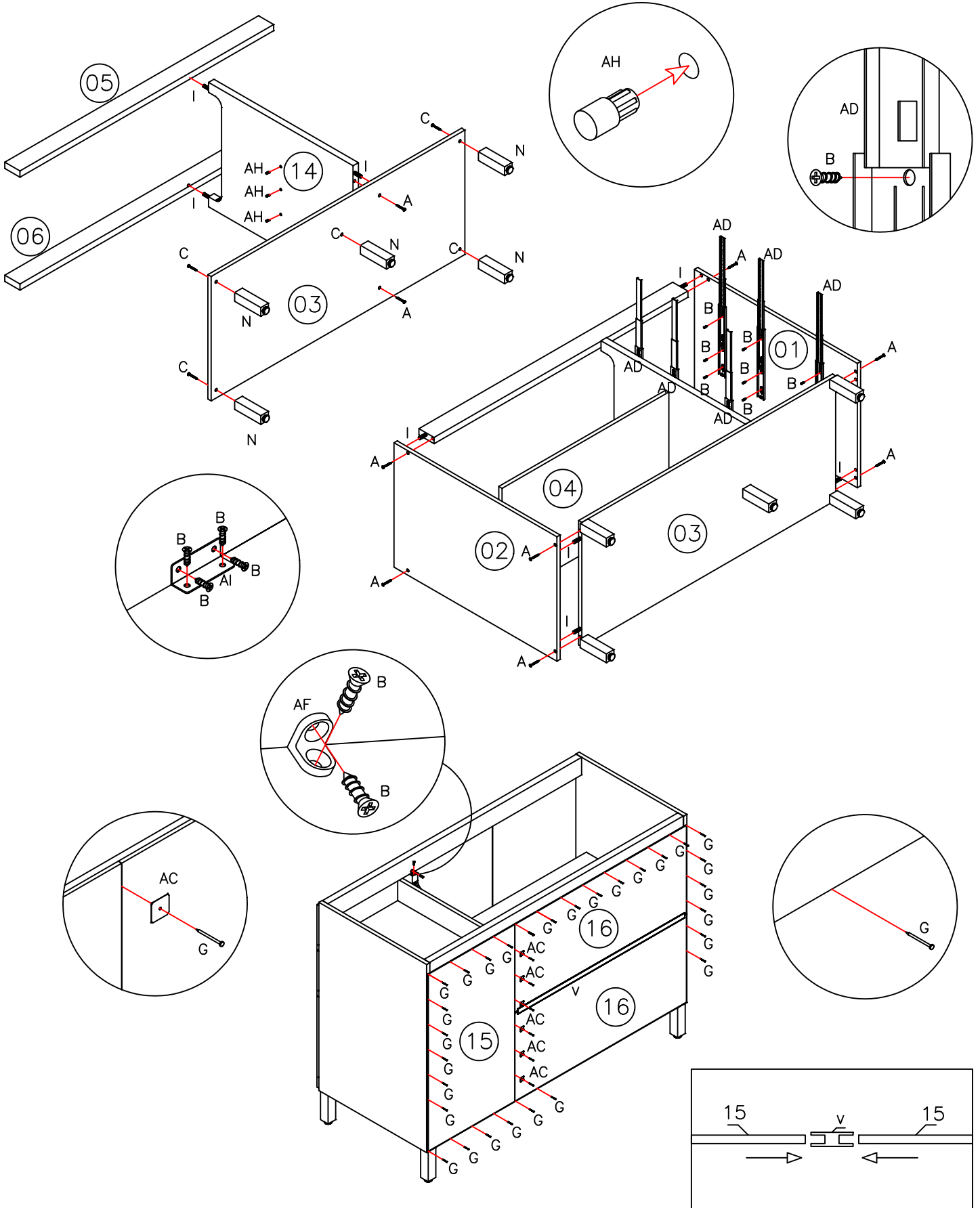

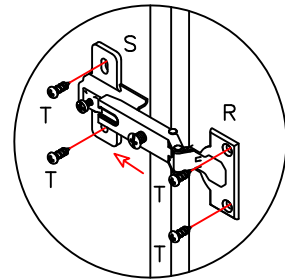
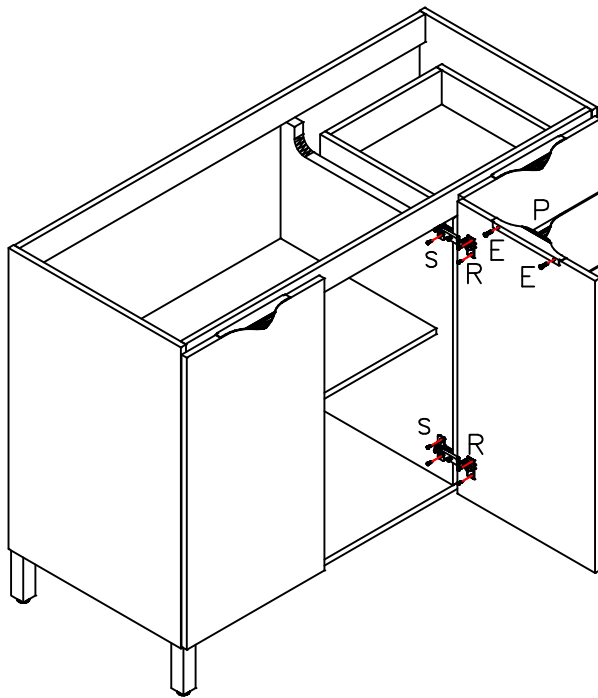

Para montar a cozinha suspensa:

- Utilize o sarrafo de apoio (07) que acompanha o móvel como apoio para sua fixação na parede, utilizando a bucha "L" e o parafuso "C".
- Em uma lateral fixe um suporte aéreo metálico "J" com o parafuso "B" e na parede com o parafuso "C" e com a bucha "L".
- Coloque uma capa "K" em cada suporte "J".

Para montar la cocina suspendida:

- Use el marco de apoyo (07) que viene con los muebles como soporte para su montaje en la pared utilizando el casquillo "L" y el tornillo "C".
- Por un lado, fije un soporte neumático metálico "J" con el tornillo "B" y la pared con el tornillo "C" y el casquillo "L".
- Coloque una cubierta "K" en cada soporte "J".

To mount the kitchen suspended:

- Use the support slat (07) board that comes with the furniture as a support for its wall mounting using the "J" bush and the "C" screw.
- On one side, fix a metallic air support "I" with the screw "B" and the wall with the screw "C" and the bushing "L".
- Place a "K" cover on each "J" bracket.

