



CAMA LUIZA SOLTEIRO

ATENÇÃO- LIMPEZA E CONSERVAÇÃO

A limpeza do móvel deve ser feita somente com pano. Não utilizar produtos abrasivos ou similares como: Cera, álcool, detergentes, tinner, lustra móveis.

GARANTIA 90 DIAS

Avárias ocasionadas na montagem do produto não se enquadram na garantia. Para solicitar componentes utilize o código identificador.







FERRAMENTAS E REQUISITOS NECESSÁRIOS



COMPONENTES

ILUSTRATIVO	COD	Nº	DESCRIÇÃO	QTD
	000	1	PÉ TRASEIRO DIREITO	1
	000	2	PÉ TRASEIRO ESQUERDO	1
	000	3	PÉ DIANTEIRO DIREITO	1
	000	4	PÉ DIANTEIRO ESQUERDO	1
	000	5	BORDA FRONTAL	1
	000	6	CABECEIRA	2
	000	7	CABECEIRA CENTRAL	1
	000	8	LASTRO	6
	000	9	BORDA LATERAL	2
	000	10	TRAVESSA DO LASTRO	5

FERRAGENS E ACESSÓRIOS

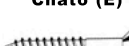
Parafuso 1/4 x 90 (F)  04 und	Chave Zeta (I)  01 und	Cavilha 8 x 40 (A)  20 und
Pregos 12 x 12 (D)  30 und	Porca Meia Lua (B)  04 und	Parafuso 7.0 x 110 (C)  08 und
		Parafuso 4,0 x 45 Chato (E)  06 und

PRODUTO MONTADO



1º PASSO

Abrir com cuidado a caixa do produto, evitar o uso de ferramentas cortantes na abertura.

2º PASSO

Separar os materiais para iniciar a montagem.

3º PASSO

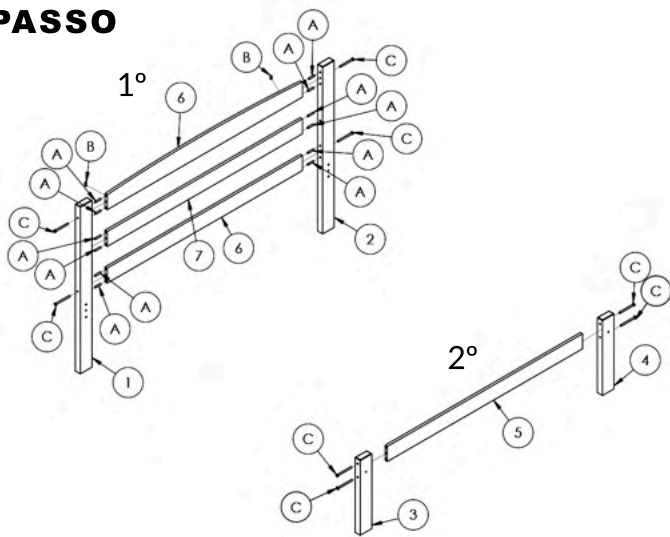

1º Passo: Fixar as Cavilhas (A) nas peças (1) e (2), fixar as peças (1) e (2) nas peças (6), (7), fixar as peças utilizando os Parafusos (C) com a Chave Zeta (I).

2º Passo: Fixar as peças utilizando os Parafusos (C) com a Chave Zeta (I)

4º PASSO

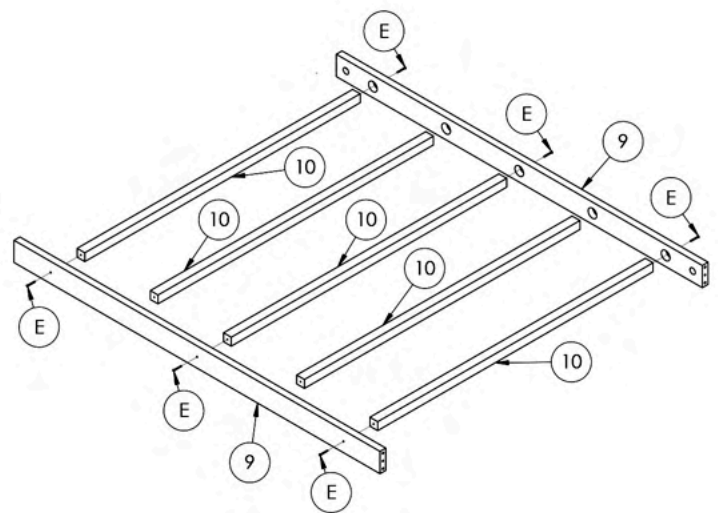

Fixar as peças (10) nas peças (9) utilizando os Parafusos (E) com uma Chave Phillips.

5º PASSO

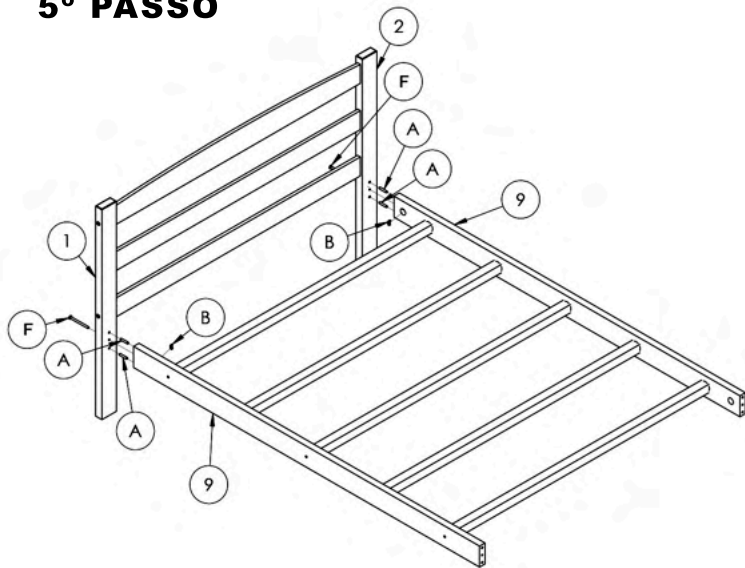

Fixar as Cavilhas (A) nas peças (1) e (2), fixar as peças (1) e (2) nas peças (9), fixar as Porca meia lua (B) nas peças (9), fixar as peças com os Parafusos (F) utilizando uma Chave Zeta (I).

6º PASSO

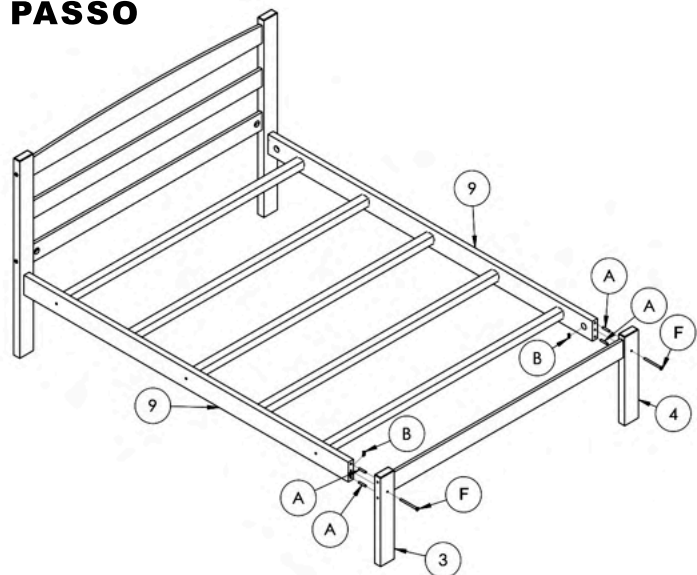

Fixar as cavilhas (A) nas peças (3) e (4), fixar as peças (3) e (4) nas peças (9), fixar as Porca meia lua (B) nas peças (9), fixar as peças com os Parafusos (F) utilizando uma Chave Zeta (I).

7º PASSO

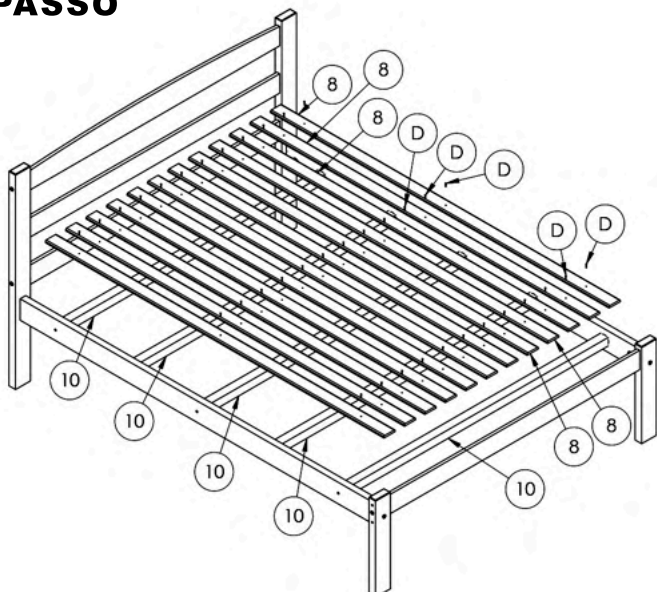

Fixar as peças (8) nas peças (10) utilizando os Pregos (D) com um Martelo.