

MÖBLER

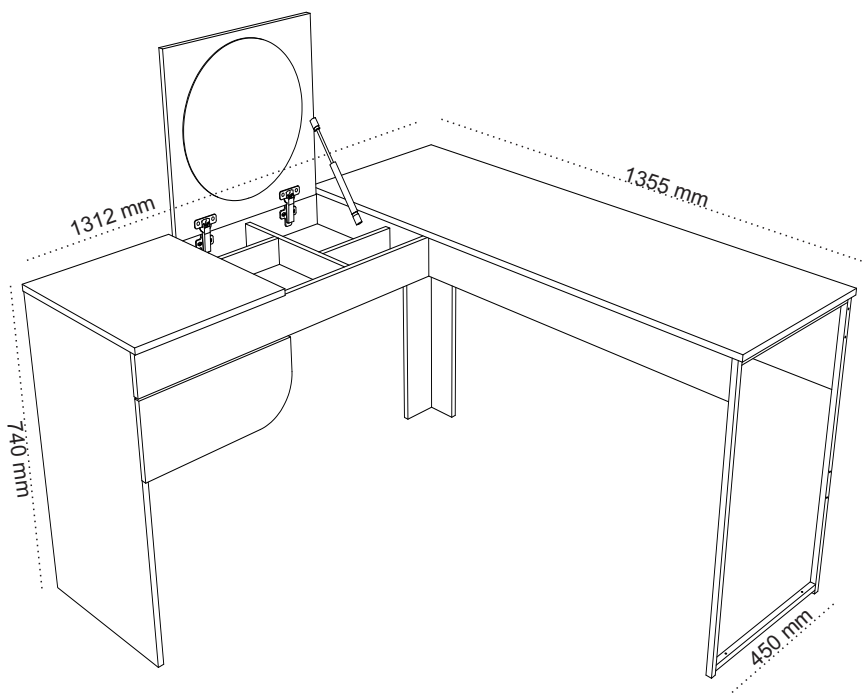

3003027 - ESC. PENTEADEIRA LUNA
511 - BRANCO FOSCO / 644 - PRETO FOSCO
715 - FREIJÓ

Parabens você acabou de adquirir um produto Bela?ex. Você tem a sua disposição que há de melhor em qualidade e design.
 Rua Floresta, Nº 08 - Jardim Santa Terezinha - Fone (0**43) 3242 - 8800 - Bela Vista do Paraíso - Paraná - www.belaflex.ind.br

Ficha técnica Hoja tecnica
 Datashet

3003027 - ESC. PENTEADEIRA LUNA

Nº	DESCRIÇÃO	CORES COLORES COLORS			Mat. Prima	MEDIDAS (mm)	Qtde.
		BCO F.	PTO F.	FREIJÓ			
01	FUNDO FONDO BOTTOM	511	644	715	MDF	0348 X 0300 X 03	01
21	LAT. ESQ. LATERAL IZQUIERDA LEFT SIDE	511	644	715	MDP	0725 X 0423 X 15	01
22	PAINEL ESQ. PANEL IZQUIERDO LEFT PANEL	511	644	715	MDP	1280 X 0220 X 15	01
23	TRAVESSA ESQ. IZQUIERDO CRUCE LEFT CROSSING	511	644	715	MDP	1296 X 0095 X 15	01
24	PAINEL DIR. PANEL DERECHO RIGHT PANEL	511	644	715	MDP	1330 X 0220 X 15	01
25	TAMPO DIR. TAPA DERECHA RIGHT TOP	511	644	715	MDP	1335 X 0450 X 15	01
26	PORTA ESPELHO PUERTA DE ESPEJO MIRROR DOOR	511	644	715	MDP	0450 X 0440 X 15	01
27	TRAVESSA DIR. SEPARADOR DERECHA RIGHT DIVIDER	511	644	715	MDP	0894 X 0095 X 15	01
28	TAMPO ESQ. TAPA IZQUIERDA LEFT TOP	511	644	715	MDP	0440 X 0406 X 15	01
29	TRAVESSA DIR. NICHOS SEPARADOR DERECHA RIGHT DIVIDER	511	644	715	MDP	0406 X 0080 X 15	01
30	TRAVESSA GAV. DIR. PLACA DE CAJÓN DERECHA RIGHT DRAWER PLATE	511	644	715	MDP	0406 X 0220 X 15	01
31	TRAVESSA GAV. PLACA DE CAJÓN DRAWER PLATE	511	644	715	MDP	0372 X 0064 X 15	01
32	FUNDO NICHOS BASE DE LOS DIVISORES PARTITIONS BASE	511	644	715	MDP	0478 X 0406 X 15	01
33	FRENTE GAV. CAJÓN DELANTERO DRAWER FRONT	511	644	715	MDF	0416 X 0180 X 15	01
34	DIVISOR NICHOS SEPARADOR CENTRAL CENTER DIVIDER	511	644	715	MDP	0406 X 0064 X 15	01
35	DIVISOR MENOR NICHOS DIVISOR NICHOS MAS PEQUEÑO SMALLER NICHOS DIVIDER	511	644	715	MDP	0224 X 0064 X 15	02
36	LAT. GAV. LADO DEL CAJÓN SIDE OF THE DRAWER	511	644	715	MDP	0300 X 0080 X 15	02
37	CONTRA FUNDO ANTECEDENTES BACKGROUND	511	644	715	MDP	0318 X 0080 X 15	01
39	PÉ TRASEIRO ESQ. PIE TRASERO IZQUIERDO LEFT REAR FOOT	511	644	715	MDP	0725 X 0095 X 15	01
40	PÉ TRASEIRO DIR. PIE TRASERO DERECHO RIGHT REAR FOOT	511	644	715	MDP	0725 X 0095 X 15	01
41	PÉ DIR LAT. PIE LATERAL DERECHO SIDE RIGHT FOOT	----	----	----	METALON	0725 X 0440 X 20	01

Para montagem:

PARA MONTAJE / TO ASSEMBLE



1 hora.

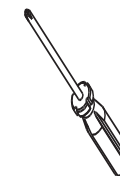
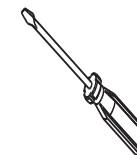















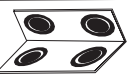

LEGENDA DE CORES

511 - BRANCO FOSCO BLANCO MATTE WHITE MATTE

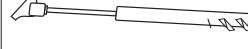

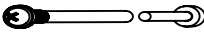





644 - PRETO FOSCO NEGRO MATTE BLACK MATTE

715 - FREIJÓ FREIJÓ

DESCRIÇÃO DE ACESSÓRIOS

Cód.	DESCRIÇÃO	Qtd.	DESENHO
A	CANTONEIRA DE METAL <small>CANTONERA DE METAL METAL CORNER</small>	09	
B	CANTONEIRA DE ZAMAC <small>CANTONERA DE ZAMAC ZAMAC CORNER</small>	04	
C	PARAFUSO 3,5 X 14 mm <small>TORNILLO 3,5*14 SCREW 3,5*14</small>	110	
D	PARAFUSO 3,5 X 40 mm <small>TORNILLO 3,5*40 SCREW 3,5*40</small>	26	
E	PARAFUSO 4,0 X 25 mm <small>TORNILLO 4,0*25 SCREW 4,0*25</small>	08	
F	CHAPA L 42 X 42 <small>PLACA DE 4 AGUJEROS 4 HOLE PLATE</small>	20	
G	DOBRADIÇA CALÇO RETA 26 mm <small>BISAGRA HINGE</small>	02	
H	SAPATA MINI DESLIZANTE (L) <small>PIES FEET</small>	04	
J	TAMPA DA CASTANHA <small>TAPA DE TAMBOR DRUM COVER</small>	16	
K	PREGO 8 X 8 <small>CLAVO 8*8 NAIL 8*8</small>	20	
L	PREGO 13 X 15 <small>CLAVO 13*15 NAIL 13*15</small>	02	
M	CAVILHA 6 X 30 mm <small>BOLSILLO DE MADERA WOODEN POCKET</small>	04	
N	PISTÃO A GÁS ABERTO <small>PISTÓN PISTON</small>	01	
P	PARAFUSO 4,0 X 50 mm <small>TORNILLO 4,0*50 SCREW 4,0*50</small>	04	
Q	PARAFUSO UNIÃO <small>TORNILLO UNION UNION SCREW</small>	04	
R	SACHÊ DE COLA <small>COLA GLUE</small>	01	
S	CORREDIÇA TELESCÓPICA 300 mm <small>CORREDERA TELESCÓPICA TELESCOPIC SLIDE</small>	01	
T	PARAFUSO 4,0 X 30 mm <small>TORNILLO 4,0*30 SCREW 4,0*30</small>	02	

1º Passo

A	CANTONEIRA DE METAL <small>CANTONERA DE METAL METAL CORNER</small>	03		J	TAMPA DA CASTANHA <small>TAPA DE TAMBOR DRUM COVER</small>	13	
C	PARAFUSO 3,5 X 14 mm <small>TORNILLO 3,5*14 SCREW 3,5*14</small>	10		K	PREGO 8 X 8 <small>CLAVO 8*8 NAIL 8*8</small>	04	
D	PARAFUSO 3,5 X 40 mm <small>TORNILLO 3,5*40 SCREW 3,5*40</small>	22		S	CORREDIÇA TELESCÓPICA 300 mm <small>CORREDERA TELESCÓPICA TELESCOPIC SLIDE</small>	01	
E	PARAFUSO 4,0 X 25 mm <small>TORNILLO 4,0*25 SCREW 4,0*25</small>	04		OBS: ALINHAR AS PÇ: 22 COM AS PÇS 39 E 40 ANTES DE PARAFUSAR. PARTE SUPERIOR E LATERAL PARA MELHOR ACABAMENTO. <small>ALINEE LAS PARTES 22 CON LAS PARTES 39 Y 40 ANTES DE FIJAR. ALIGN PARTS 22 WITH PARTS 39 AND 40 BEFORE FIXING.</small>			
H	SAPATA MINI DESLIZANTE (L) <small>PIES FEET</small>	04					

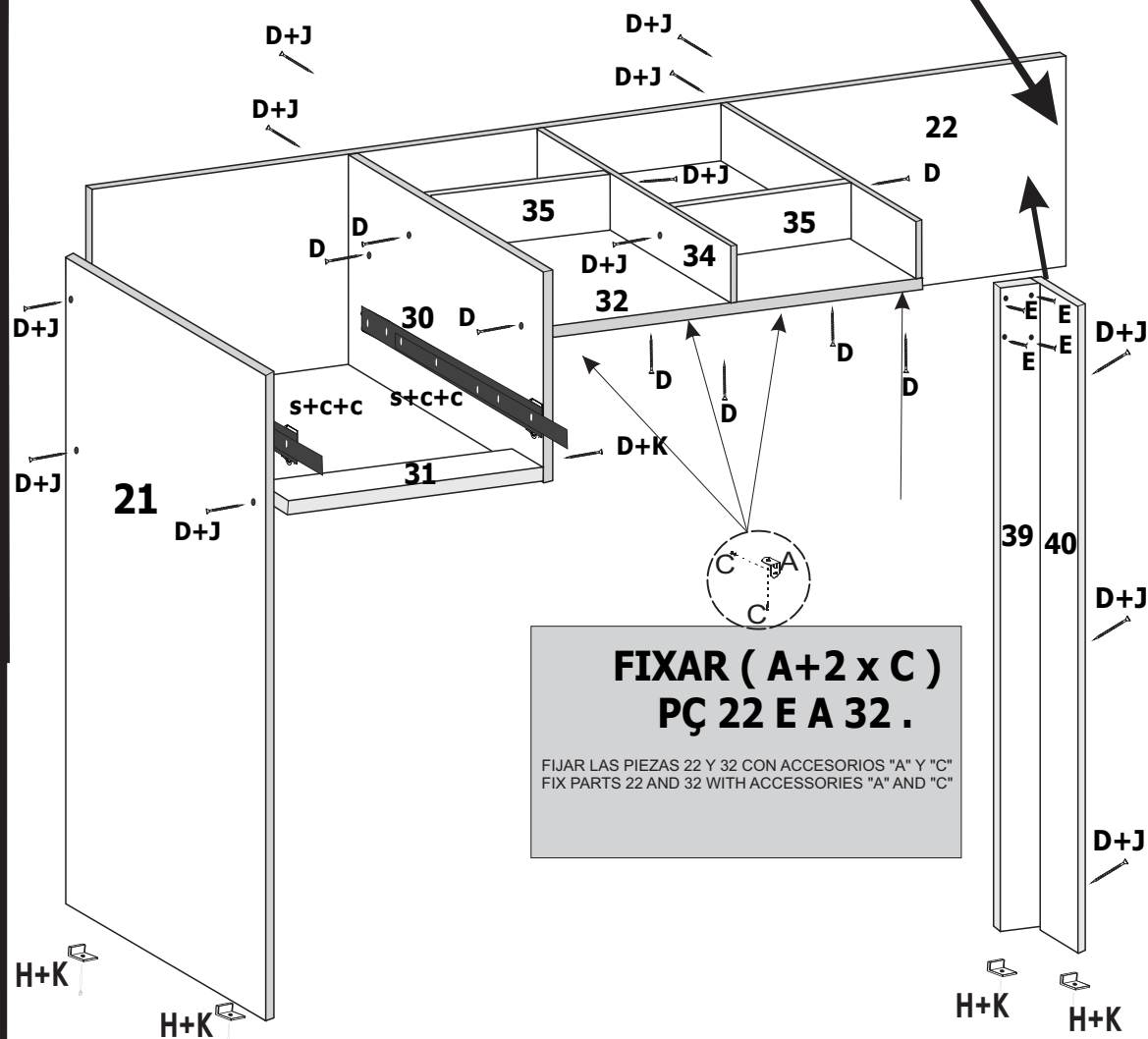

2º Passo

B	CANTONEIRA DE ZAMAC CANTONERA DE ZAMAC ZAMAC CORNER	04		E	PARAFUSO 3,5 X 40 mm TORNILLO 3,5*40 SCREW 3,5*40	04	
C	PARAFUSO 3,5 X 14 mm TORNILLO 3,5*14 SCREW 3,5*14	52		F	CHAPA L 42 X 42 PLACA DE 4 AGUJEROS 4 HOLE PLATE	11	
D	PARAFUSO 4,0 X 25 mm TORNILLO 4,0*25 SCREW 4,0*25	04		J	TAMPA DA CASTANHA TAPA DE TAMBOR DRUM COVER	03	

OBS:

ALINHAR AS PÇ: 22,39 E 40 COM A PÇ 24 ANTES DE PARAFUSAR.
ALINEE LAS PIEZAS 22, 39 Y 40 CON LA PARTE 24 ANTES DE FIJAR
ALIGN PARTS 22, 39 AND 40 WITH PART 24 BEFORE FIXING

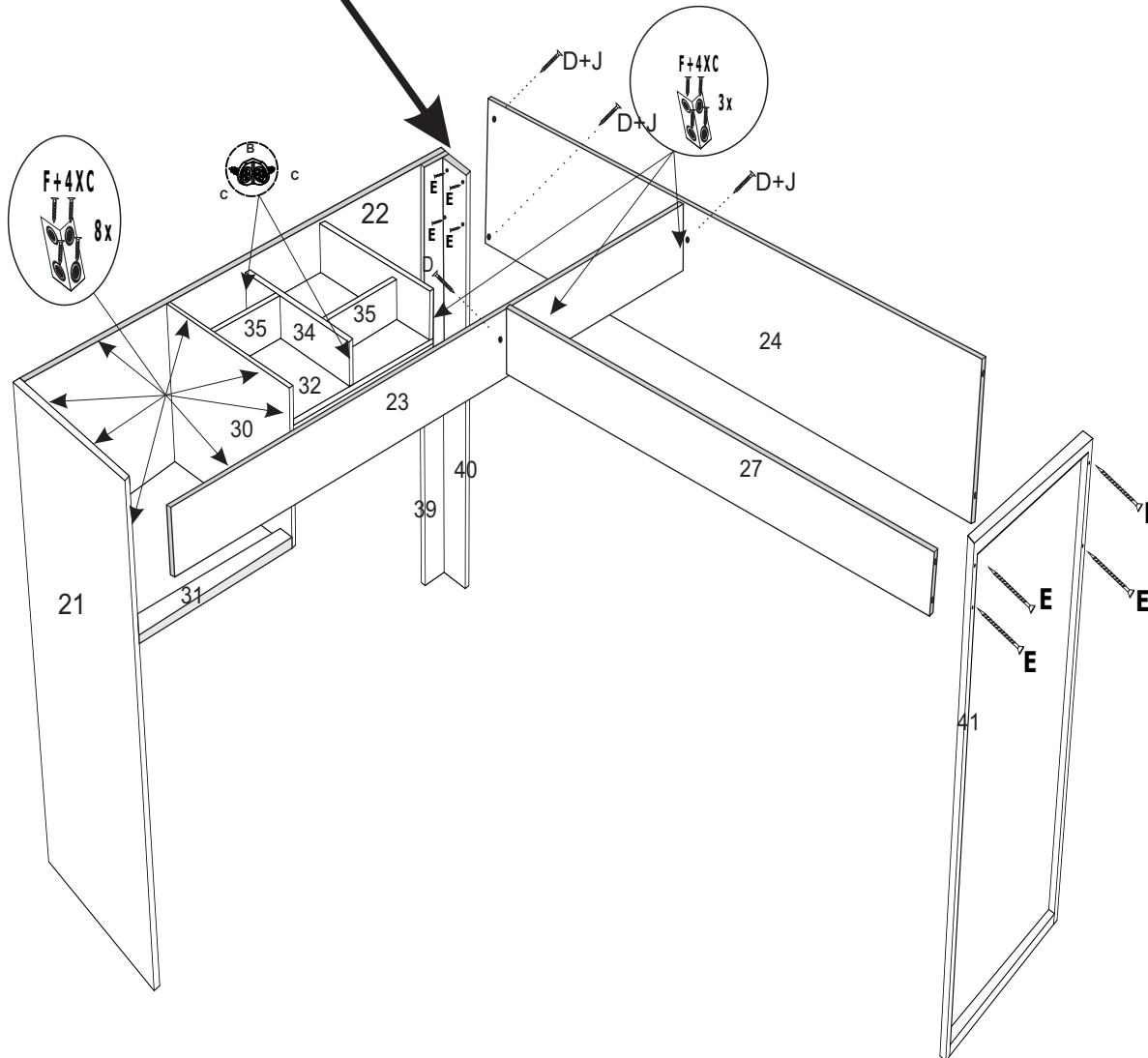

3º Passo

A	CANTONEIRA DE METAL CANTONERA DE METAL METAL CORNER	06		L	PREGO 13 X 15 CLAVO 13*15 NAIL 13*15	02	
C	PARAFUSO 3,5 X 14 mm TORNILLO 3,5*14 SCREW 3,5*14	48		N	PISTÃO A GÁS ABERTO PISTON PISTON	01	
F	CHAPA L 42 X 42 PLACA DE 4 AGUJEROS 4 HOLE PLATE	07		Q	PARAFUSO UNIÃO TORNILLO UNION UNION SCREW	04	
G	DOBRAÇA CALÇO RETA 26 mm BISAGRA HINGE	02		R	SACHÊ DE COLA COLA GLUE	01	
K	PREGO 8 X 8 CLAVO 8*8 NAIL 8*8	20		S	CORREIÇA TESCÓPICA 300 mm CORREDERA TELESCÓPICA TELESCOPIC SLIDE	01	

4 - PARAFUSO UNIÃO (LETRA Q) PARA UNIR A DOBRAÇA COM A PÇ Nº 22
UTILICE EL TORNILLO DE LA UNIDAD "Q" PARA UNIR LA BISAGRA CON LA PARTE 22
USE THE UNIT SCREW "Q" TO JOIN THE HINGE WITH THE PART 22

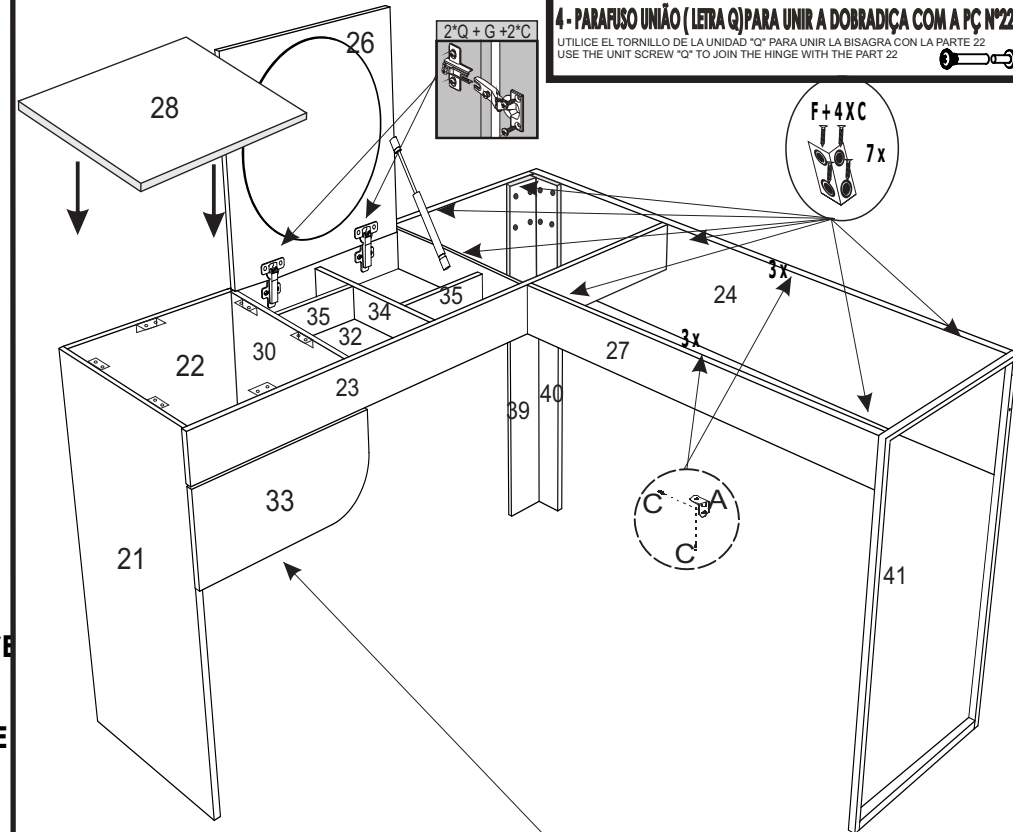

MONTAGEM DA GAVETA

ASAMBLEA DEL CAJÓN
ASSEMBLY OF THE DRAWER

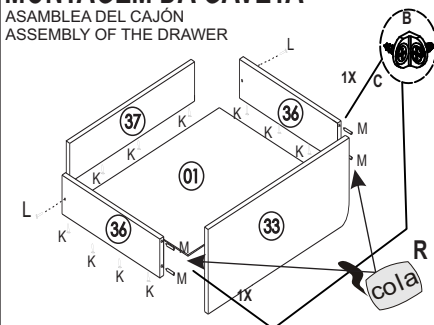

OBS: FIXAR ACESSÓRIO LETRA C NA PÇ Nº 33.

FIJE LA LETRA DE ACCESORIOS C A LA PIEZA NÚMERO 33
ATTACH ACCESSORY LETTER C TO PIECE NUMBER 33

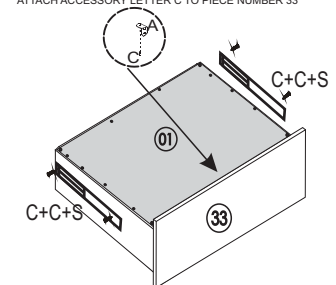

4 ° Passo

ATENÇÃO !!!

**ALINHAR AS PÇ: 28,26 COM A PÇ 25 ANTES DE PARAFUSAR.
DEIXANDO OS MESMO ESPAÇO.**

ALINEE LAS PIEZAS 28 Y 26 CON LA PARTE 25 ANTES DE FIJAR (DEJAR EL MISMO ESPACIO)
ALIGN PARTS 28 AND 26 WITH PIECE 25 BEFORE FIXING (LEAVING THE SAME SPACE)

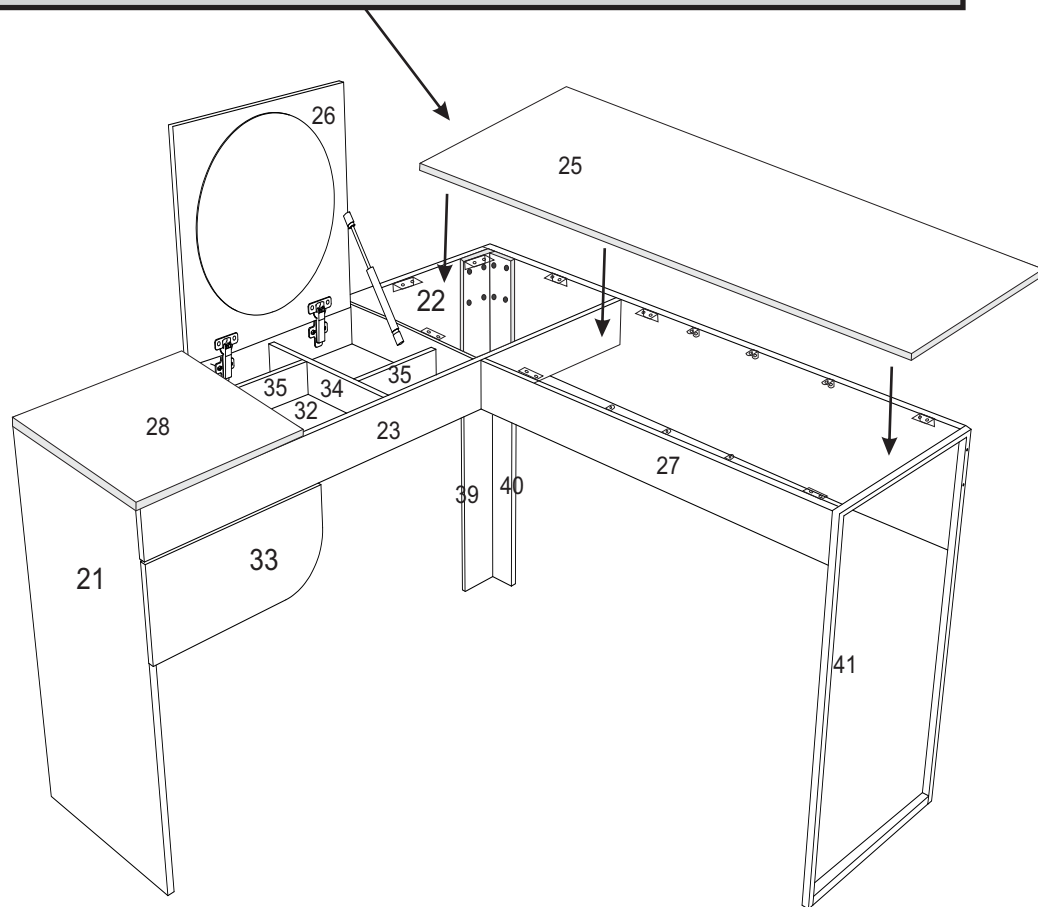

5 ° Passo

T	PARAFUSO 4,0 X 30 mm TORNILLO 4,0*30 SCREW 4,0*30	02	
---	---	----	--

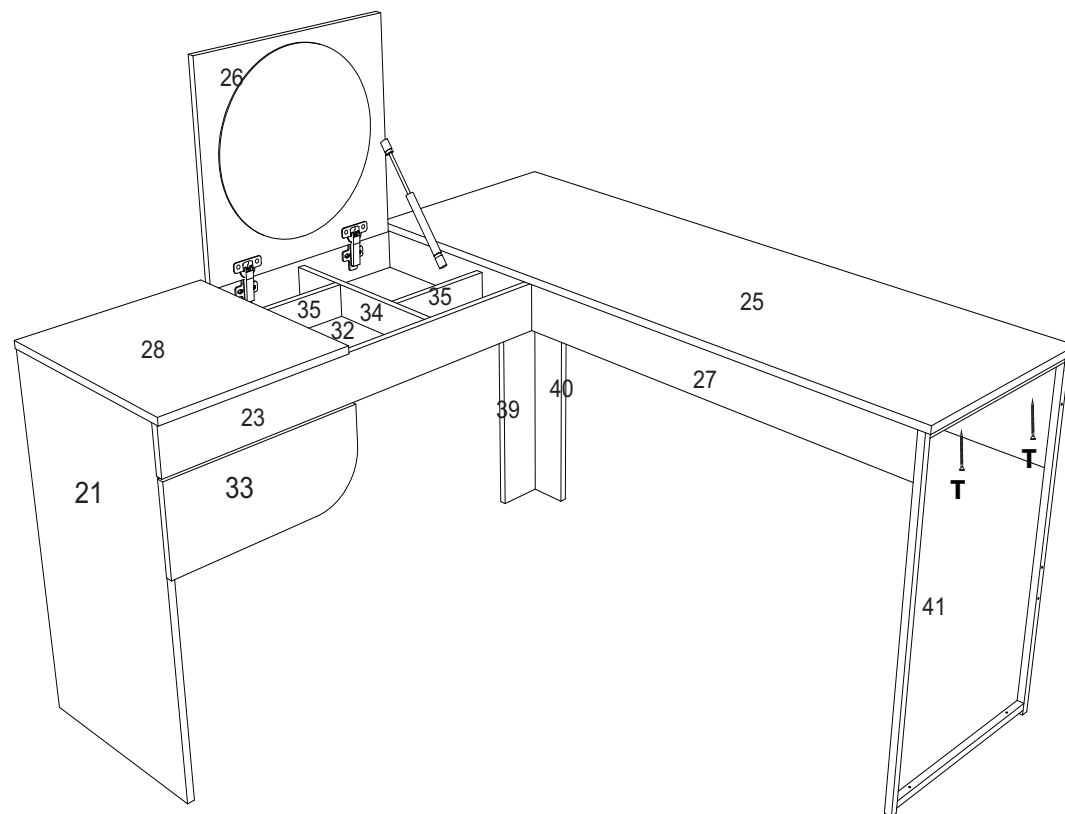

6 ° Passo

