

6022 - GR ÂMBAR 6 PORTAS



Tabela de peças - Pieces list - Lista de piezas

SEQ.	REF.	DESCRIÇÃO	DESCRIPTION	DESCRIPCIÓN	MAT.PRIMA	COMP.	LARG.	ESP.	QTD.
1	305930	Rodapé frontal	front footer	pie de página frontal	MDP	1512	88	12	1
2	305931	Rodapé traseiro	back footer	pie de página posterior	MDP	1512	88	12	1
3	305932	Base esquerda	left base	base izquierda	MDP	508	450	12	1
4	305933	Base direita	right base	base derecha	MDP	508	450	12	1
5	305934	Lateral divisória gaveteiro esquerda	Left side drawer divider	Divisor del cajón del lado izquierdo	MDP	450	320	12	1
6	305935	Lateral divisória gaveteiro direita	Right side drawer divider	Divisor del cajón del lado derecho	MDP	450	320	12	1
7	305936	Lateral esquerda	left side	lado izquierdo	MDP	1820	450	12	1
8	305937	Lateral direita	Right side	Lado derecho	MDP	1820	450	12	1
9	305938	Tampo gaveteiro	drawer top	parte superior del cajón	MDP	524	450	12	1
10	305939	Batente frontal direito	Right front stop	Tope delantero derecho	MDP	896	72	12	1
11	305940	Batente traseiro direito	right rear stop	tope trasero derecho	MDP	896	72	12	1
12	305941	Batente frontal esquerdo	left front stop	tope delantero izquierdo	MDP	896	72	12	1
13	305942	Batente traseiro esquerdo	left rear stop	tope trasero izquierdo	MDP	896	72	12	1
14	305943	Base maleiro	maleiro base	maleiro base	MDP	1512	450	12	1
15	305944	Batente frontal superior	upper front stop	tope delantero superior	MDP	400	72	12	2
16	305945	Batente traseiro superior	top rear stop	tope trasero superior	MDP	400	72	12	2
17	305946	Chapéu	Hat	Sombrero	MDP	1512	450	12	1
18	305947	Vista superior	Upper view	Vista superior	MDP	1536	72	15	1
19	305948	Prateleira direita	right shelf	estante derecho	MDP	496	450	12	1
20	305949	Porta maior	bigger door	puerta mas grande	MDP	1647	251	15	4
21	305950	Porta menor	smaller door	puerta más pequeña	MDP	1316	251	15	2
22	305951	Frente gaveta	drawer front	frente del cajón	MDP	504	160	15	2
23	700416	Lateral gaveta	drawer side	lado del cajón	MDP	350	100	12	4
24	305953	Fundo gaveta	drawer bottom	fondo del cajón	HDF	472	355	3	2
25	305954	Contra fundo	against background	contra el fondo	MDP	448	88	12	2
26	305955	Fundo	Background	Fondo	HDF	1664	510	3	3
27	305956	Trava rodapé	footer lock	bloqueo de pie de página	MDP	404	88	12	1

INSTRUÇÃO MONTAGEM PRODUTO
Intructions to Assembly / Instrucciones de montaje

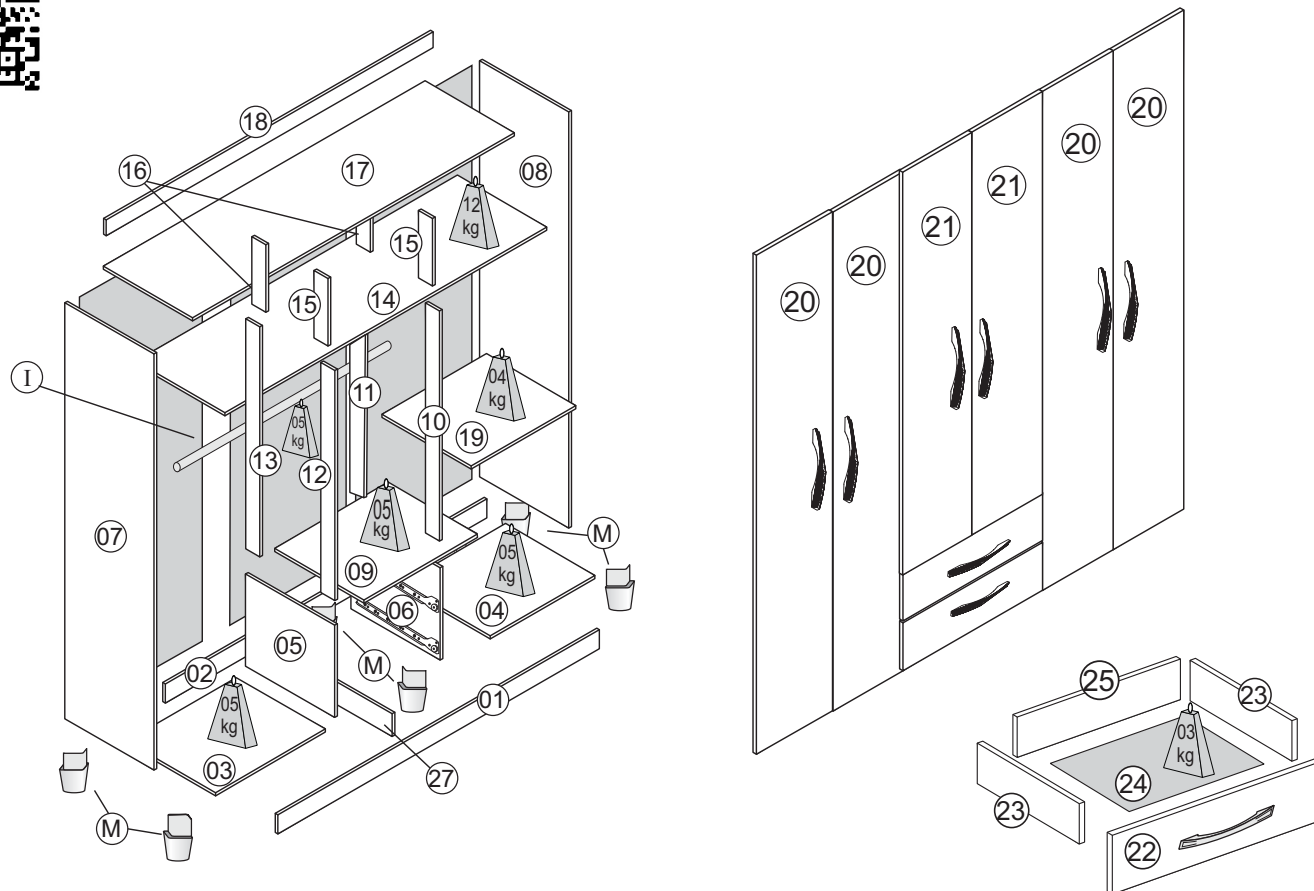
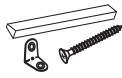

Separe as peças e acessórios de maneira organizada
 Separate parts and accessories in way organized
 Separe las piezas y accesorios de manera organizada

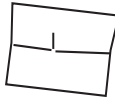

Forrar o chão com o papelão das embalagens.
 Cover the floor with the cardboard
 Cubra el suelo con la embalaje de cartón



É necessário 01 pessoa para montar o produto
 01 person is required to assemble the product
 Se requiere 01 persona para ensamblar el producto.

O produto deve ser a montado por um profissional qualificado
 The product must be assembly by a professional
 El producto debe ser ensamblado por un profesional calificado

Ferramentas necessárias
 (não fornecidas)

Not include tools / No herramientas



CUIDADO PARA CONSERVAÇÃO E LIMPEZA DO MÓVEL
Care to conservation and clean / Cuidados de limpieza

Peso máximo de carga informado refere-se a objetos distribuido de maneira uniforme sobre toda área de contato da peça



The maximum load weight informed refers to objects distributed evenly over the entire contact area of the part
 Conjunto de carga máxima de peso se refiere a objetos distribuidos uniformemente sobre toda el área de contacto de la pieza de trabajo.



Não molhar o móvel e não expor em lugar úmido
 Do not wet the mobile and do not expose in a wet place
 No moje el producto y no exponer en un lugar húmedo



Não expor o móvel próximo de fontes de calor.
 Do not expose the mobile near heat sources
 no exponga cercano de fuentes de calor



Não usar produtos abrasivos.
 Do not use abrasive products.
 No utilice productos abrasivos.



Limpe com flanela limpa e seca.
 Clean with dry cloth
 Limpieza con un paño limpio y seco

LISTA DE ACESSÓRIOS E FERRAGENS / ACCESSORIES AND HARDWARE / ACCESORIOS Y HARDWARE



A- 700542-Cavilha 6x30 (18x)
 peg / cerrojo



B- 700543-Cavilha 6x60 (12x)
 peg / cerrojo



C- 700137-Parafuso 4,5x45 (32x)
 screw / tornillo



D- 700124-Parafuso 3,5x25 (24x)
 screw / tornillo



E- 700131-Parafuso 4,0x20 (06x)
 screw / tornillo

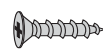

F- 700120-Parafuso 3,0x12 (50x)
 screw / tornillo



G- 700121-Parafuso 3,5x12 (24x)
 screw / tornillo



H- 700157-Prego (80x)
 nail / clavo



I - 700417-Bastão madeira (01x)
 wooden stick / palo de madera

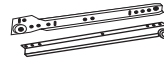

J - 700111-Corrediça (02x)
 runners / corredera



K- 700435-Suporte 'U' fechado (02x)
 closed U support / soporte U cerrado



L- 700395-Dobradiça (18x)
 700390-Calço(18x)
 hinge / bisagra



M- 700230-Pé PVC (06x)
 PVC foot / Pie de PVC



N- 700538-Cantoneira (15x)
 corner / esquina



O- 700547-Junção (16x)
 junction / juncion



P - 700516-Sache cola 20g (01x)
 Glue / Goma



Q- 700194-Puxador (08x)
 handle / manija



R- 700434-Suporte 'U' aberto (01x)
 U open support / U soporte abierto



S- 700126-Parafuso 4.0x12 (72x)
 screw / tornillo



T - 700516-Tapa furo (18x)
 cover hole/
 agujero de la cubierta

01° PASSO - Fixar as peças 03 04 nas peças 01 e 02, fixar as peças 05 e 06 nas peças 03 e 04, fixar as peças 07 e 08 nas peças 01,02,03 e 04

01° STEP - Fix parts 03 04 in parts 01 and 02, fix parts 05 and 06 in parts 03 and 04, fix parts 07 and 08 in parts 01,02,03 and 04

01° PASO - Fije las piezas 03 04 en las piezas 01 y 02, fije las piezas 05 y 06 en las piezas 03 y 04, fije las piezas 07 y 08 en las piezas 01, 02, 03 y 04

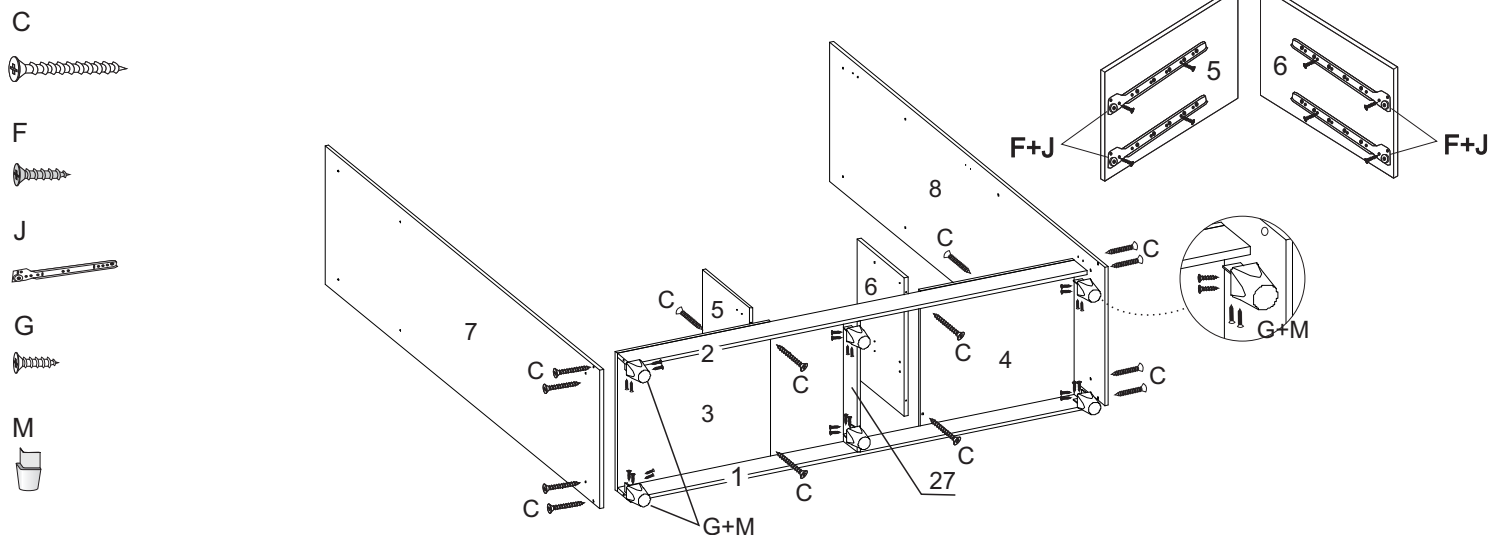

02° PASSO - Fixar a peça 09 nas peças 05 e 06, fixar a peça 14 nas peças 07 e 08, fixar as peças 10,11,12 e 13 nas peças 09 e 14

02° STEP - Fix part 09 to parts 05 and 06, fix part 14 to parts 07 and 08, fix parts 10,11,12 and 13 to parts 09 and 14

02° PASO - Fije la pieza 09 a las piezas 05 y 06, fije la pieza 14 a las piezas 07 y 08, fije las piezas 10, 11, 12 y 13 a las piezas 09 y 14

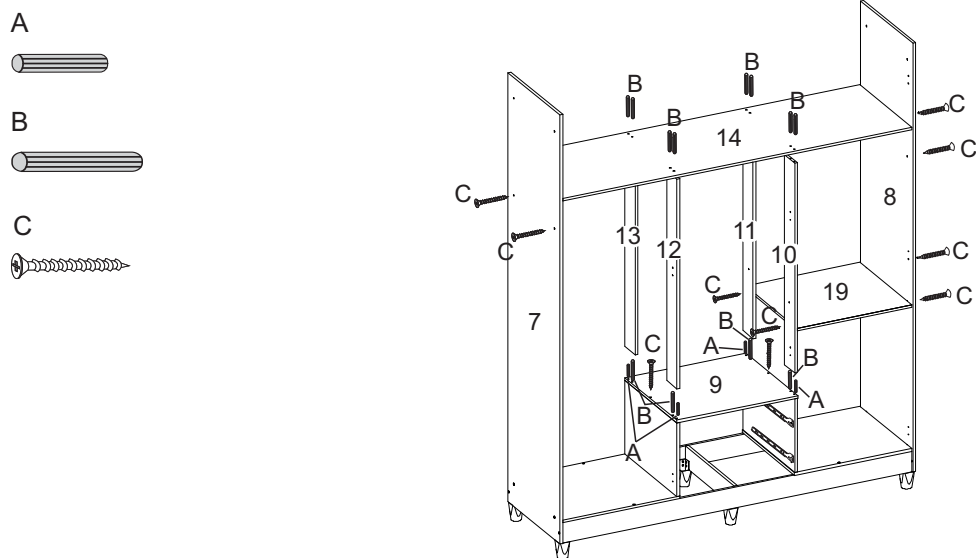

03° PASSO - Fixar a peça 17 nas peças 07 e 08, fixar as peças 15 e 16 nas peças 14 e 17

03° STEP - Attach part 17 to parts 07 and 08, attach parts 15 and 16 to parts 14 and 17

03° PASO - Adjunte la pieza 17 a las piezas 07 y 08, conecte las piezas 15 y 16 a las piezas 14 y 17

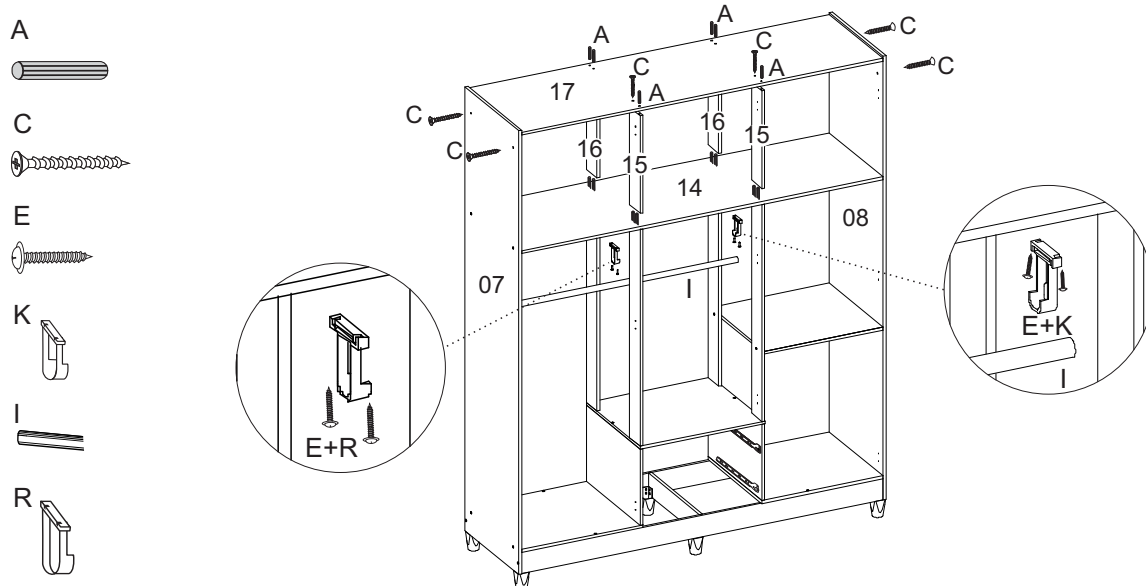

04° PASSO - Fixar as peças 16 e 17 nas peças 05,06,08 e 11, fixar a peça 15 nas peças 05,06 e 13
 04° STEP - Attach parts 16 and 17 to parts 05,06,08 and 11, attach part 15 to parts 05,06 and 13
 04° PASO - Fije las piezas 16 y 17 a las piezas 05, 06, 08 y 11, fije la pieza 15 a las piezas 05, 06 y 13

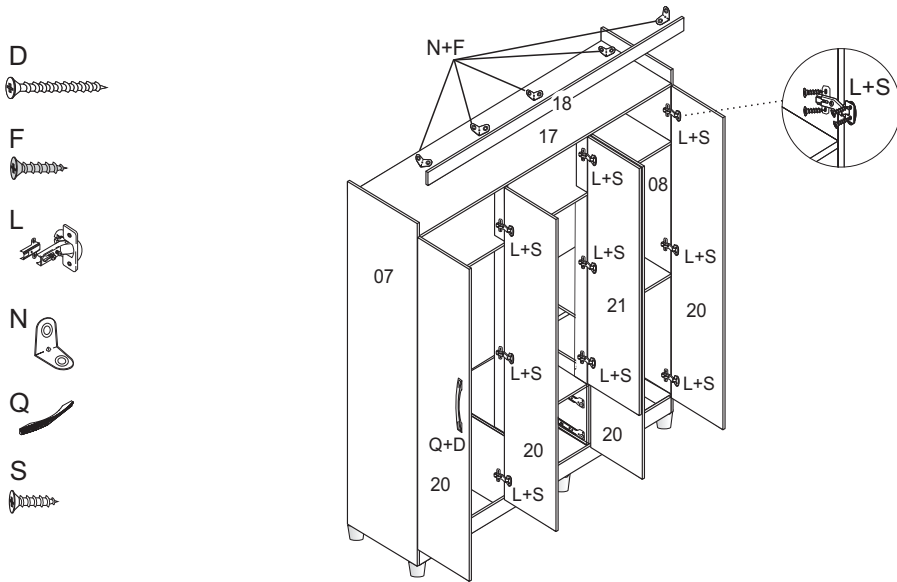

05° PASSO - Fixar as peças 23 nas peças 22 e 25, fixar a peça 24 nas peças 22,23 e 25
 05° STEP - Fix parts 23 to parts 22 and 25, fix part 24 to parts 22, 23 and 25
 05° PASO - Fije las piezas 23 a las piezas 22 y 25, fije la pieza 24 a las piezas 22, 23 y 25

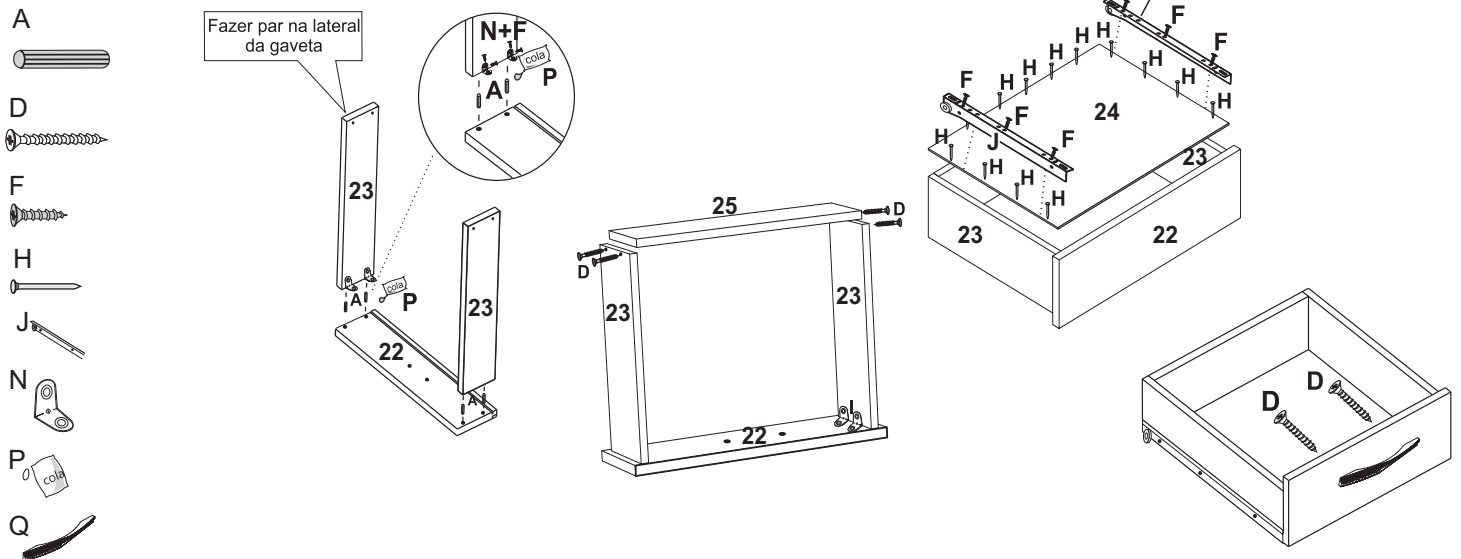

06° PASSO - Fixar as peças 26 utilizando os acessórios H e O
 06° STEP - Fix parts 26 using accessories H and O
 06° PASO - Fije las piezas 26 con los accesorios H y O

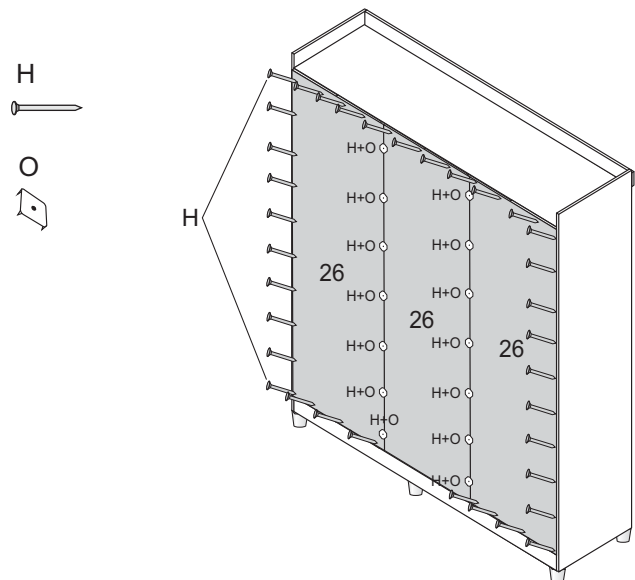

Aspecto Final

Final Aspect / Aspecto Final

