

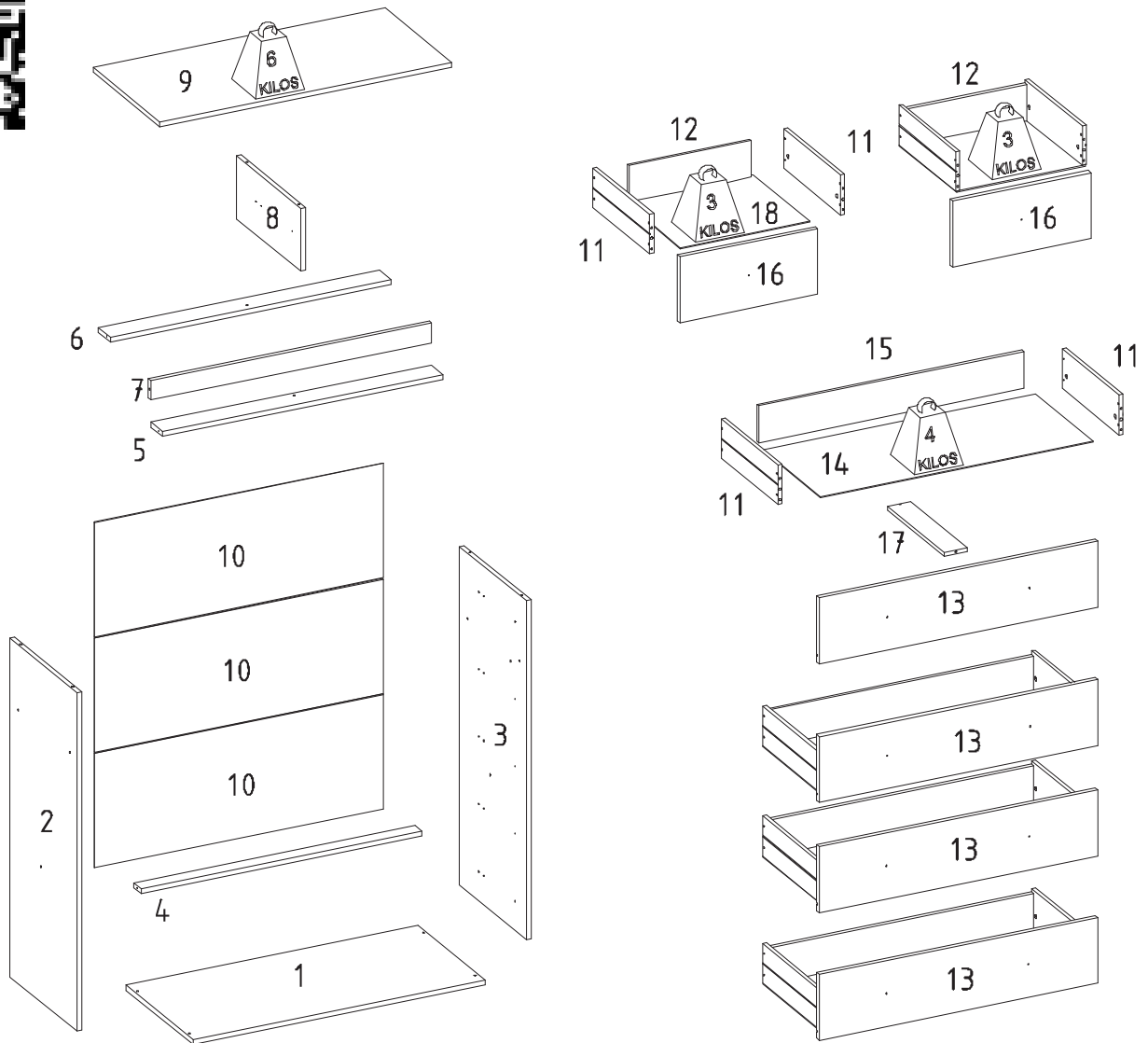

1080 - COMODA VITTORIA



LISTA DE PEÇAS / Pieces List / Lista de Piezas

SEQ.	REF.	DESCRIÇÃO	DESCRIPTION	DESCRIPCIÓN	MAT.PRIMA	COMP.	LARG.	ESP.	QTD.
1	315955	Base	Base	Base	MDP	900	410	15	1
2	315956	Lateral esquerda	Left side	Lado izquierdo	MDP	1022	410	15	1
3	315957	Lateral direita	Right side	Lado derecho	MDP	1022	410	15	1
4	315958	Trava gaveta	Drawer lock	Cerradura del cajón	MDP	866	44	15	1
5	315959	Travessa frontal	Traverse frontal	Traverse frontal	MDP	866	72	15	1
6	315960	Travessa traseira	Rear Tray	Bandeja trasera	MDP	866	72	15	1
7	315961	Trava da vista	View lock	Ver bloqueo	MDP	866	60	15	1
8	315962	Divisoria	Partition	Partición	MDP	394	190	15	1
9	315963	Tampo	Cover	Caja de resonancia	MDP	900	412	15	1
10	315964	Fundo	Bottom	Antecedentes	HDF	890	345	3	3
11	700531	Lateral gaveta	Side drawer	Cajón lateral	MDP	350	120	12	12
12	315967	Contra fundo menor	Against smaller background	Contra un fondo más pequeño	MDP	377	110	12	2
13	315968	Frente gaveta	Drawer front	Frente del cajón	MDP	858	199	15	4
14	315969	Fundo gaveta	Bottom drawer	Cajón inferior	HDF	839	355	3	4
15	315970	Contra fundo	Against background	Contra el fondo	MDP	817	110	12	4
16	315971	Frente gaveta menor	Smaller drawer front	Frente de cajón más pequeño	MDP	427	199	15	2
17	315972	Apoio de gaveta	Drawer support	Soporte de cajones	MDP	350	72	12	4
18	315973	Fundo gaveta menor	Smaller drawer bottom	Fondo de cajón más pequeño	HDF	399	350	3	2

DETALHAMENTO
DETAL / DETALLES

DETALHAMENTO
DETAL / DETALLES

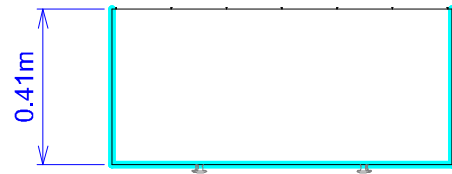
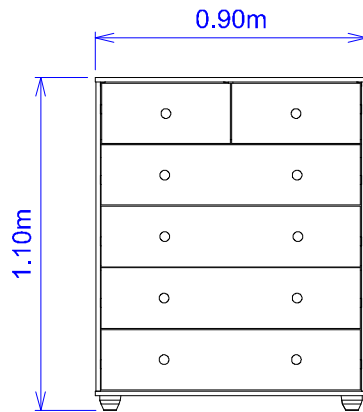

Dimensão do Produto: (L X A X P) 0.90X 1.10 X 0.40

INSTRUÇÃO MONTAGEM PRODUTO
Instructions to Assembly / Instrucciones de montaje



Seperare as peças e acessórios de maneira organizada
Separate parts and accessories in way organized
Separe las piezas y accesorios de manera organizada



Forrar o chão com o papelão das embalagens.
Cover the floor with the cardboard
Cubra el suelo con la embalaje de cartón



É necessário 01 pessoa para montar o produto
It is necessary one person to assembly
Es necesario una persona para ensamblar

O produto deve ser a montado por um profissional qualificado
The product must be assembly by a professional
El producto debe ser ensamblado por un profesional calificado

Ferramentas necessárias
(não fornecidas)
Not include tools / No herramientas



CUIDADO PARA CONSERVAÇÃO E LIMPEZA DO MÓVEL
Care to conservation and clean / Cuidados de limpieza



O peso máximo de carga informado refere-se a objetos distribuído de maneira uniforme sobre toda área de contato da peça
Set maximum weight load refers to objects distributed uniformly over the entire contact area of the workpiece.
Conjunto de carga máxima de peso se refiere a objetos distribuidos uniformemente sobre toda el área de contacto de la pieza de trabajo.



Não molhar o móvel e não expor em lugar úmido
Do not wet the mobile and do not expose in a wet place
No moje el producto y no exponer en un lugar húmedo



Não expor o móvel próximo de fontes de calor.
Do not expose the mobile near heat sources
no exponga cercano de fuentes de calor



Não usar produtos abrasivos.
Do not use abrasive products.
No utilice productos abrasivos.



Limpe com flanela limpa e seca.
Clean with dry cloth
Limpieza con un paño limpio y seco

LISTA DE ACESSÓRIOS E FERRAGEM / ACCESSORIES AND HARDWARE / ACCESORIOS Y EQUIPOS



A- 700137-Parafuso 4,5x45 (12x)
screw / tornillo



B- 700124-Parafuso 3,5x25 (38x)
screw / tornillo

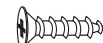

C- 700121-Parafuso 3,5x12 (96x)
screw / tornillo



D- 700148-Tambor Minifix (12x)
Minifix Drum /
Tambor minifix



E- 700146-Parafuso minifix (12x)
Minifix screw /
Tornillo minifix



F- 700542-Cavilha 6x30 (36x)
peg / cerrojo



G- 700538-Cantoneira (10x)
corner / esquina



H- 700157-Prego (109x)
nail / clavo



I - 700113-Corredixa (6x)
runners / corredera



J- 700533-Pé (4x)
foot/pie



K-700136-Parafuso 4,5x35 (4x)
screw/tornillo



L- 700532-Perfil H (2x)
Frame / Perfil









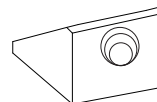



M- 700419-Tapa furo minifix (30x)
Minifix cover /
Tapa minifix

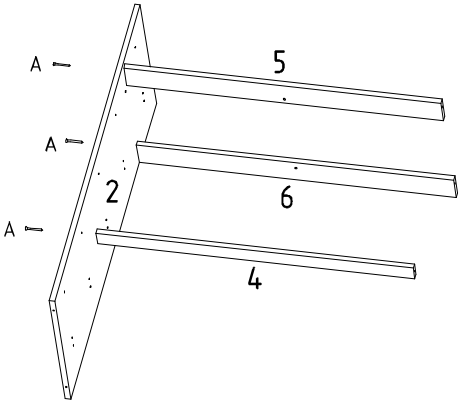
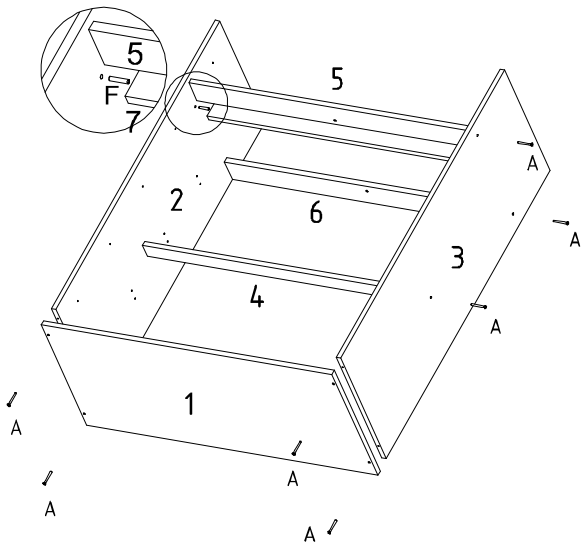

N- 700192-Puxador (10x)
handle / manija

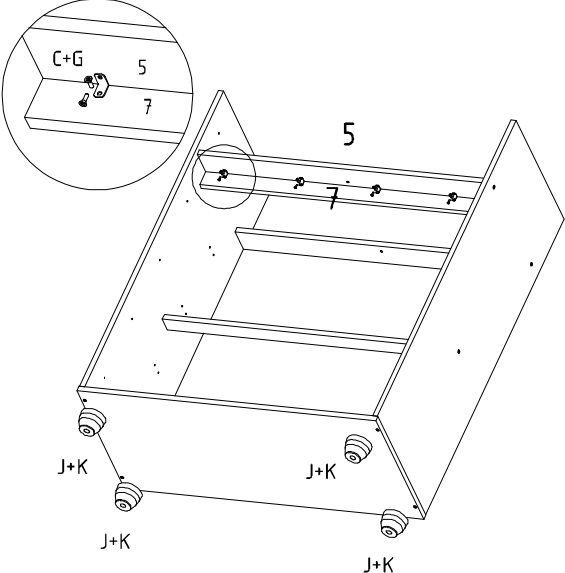
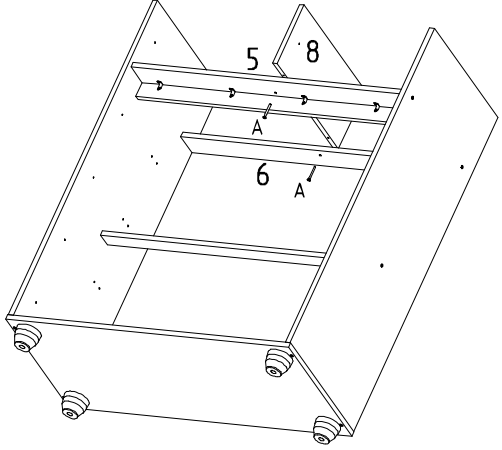

O - 700433-Suporte angular (4x)
Angled support /
Soporte en ángulo

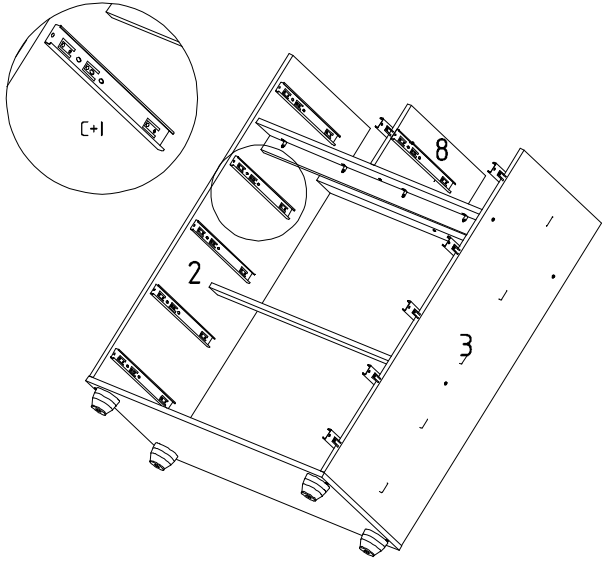
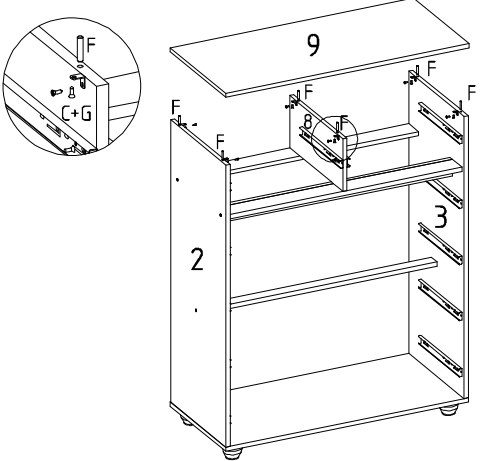
01° PASSO	Fixar peças 4,5 e 6 na peça 2	02° PASSO	Fixar peças 4,5 e 6 na peça 3 , fixar peça 1 nas peças 2 e 3
01° STEP	Attach parts 4,5 and 6 to part 2	02° STEP	Attach parts 4,5 and 6 to part 3, fix part 1 to parts 2 and 3
01° PASO	Adjunte las partes 4,5 y 6 a la parte 2	02° PASO	Adjunte las partes 4,5 y 6 a la parte 3, fije la parte 1 a las partes 2 y 3
A		A	
-		F	
-			
-			
-			
-			
			
03° PASSO	Fixar peça 7 na peça 5	04° PASSO	Fixar peça 8 nas peças 5 e 6
03° STEP	Attach part 7 to part 5	04° STEP	Attach part 8 to parts 5 and 6
03° PASO	Adjunte la parte 7 a la parte 5	04° PASO	Adjunte la parte 8 a las partes 5 y 6
C		A	
G		-	
K		-	
J		-	
			
05° PASSO	Fixar acessórios (C+I) nas peças 2,3 e 8	06° PASSO	Fixar peça 9 nas peças 2,3 e 8
05° STEP	Attach accessories (C + I) to parts 2,3 and 8	06° STEP	Attach part 9 to parts 2,3 and 8
05° PASO	Conecte los accesorios (C + I) a las partes 2,3 y 8	06° PASO	Adjunte la parte 9 a las partes 2,3 y 8
C			
I			
			

07° PASSO	Fixar peça 10 no produto utilizando os acessórios (H+L+O)	08° PASSO	Fixar peças 11 nas peças 12 e 16 , fixar peça 18 nas peças 11 e 12
07° STEP	Attach part 10 to the product using the accessories (H + L + O)	08° STEP	Attach parts 11 to parts 12 and 16, fix part 18 to parts 11 and 12
07° PASO	Conecte la parte 10 al producto utilizando los accesorios (H + L + O)	08° PASO	Conecte las partes 11 a las partes 12 y 16, fije la parte 18 a las partes 11 y 12
H T L - - - -		B C D E F H I N M O	
09° PASSO	Fixar peças 11 nas peças 13 e 15 , fixar peças 14 e 17 na peças 11 e 15	10° PASSO	Aspecto final do produto
09° STEP	Attach parts 11 to parts 13 and 15, attach parts 14 and 17 to parts 11 and 15	10° STEP	Final product aspect
09° PASO	Conecte las partes 11 a las partes 13 y 15, fije las partes 14 y 17 a las partes 11 y 15	10° PASO	Aspecto final del producto
B C D E F H I N M		- - - - - - -	
11° PASSO	-	12° PASSO	-
11° STEP	-	12° STEP	-
11° PASO	-	12° PASO	-
- - - - - -			