

CÔMODA DUNAS

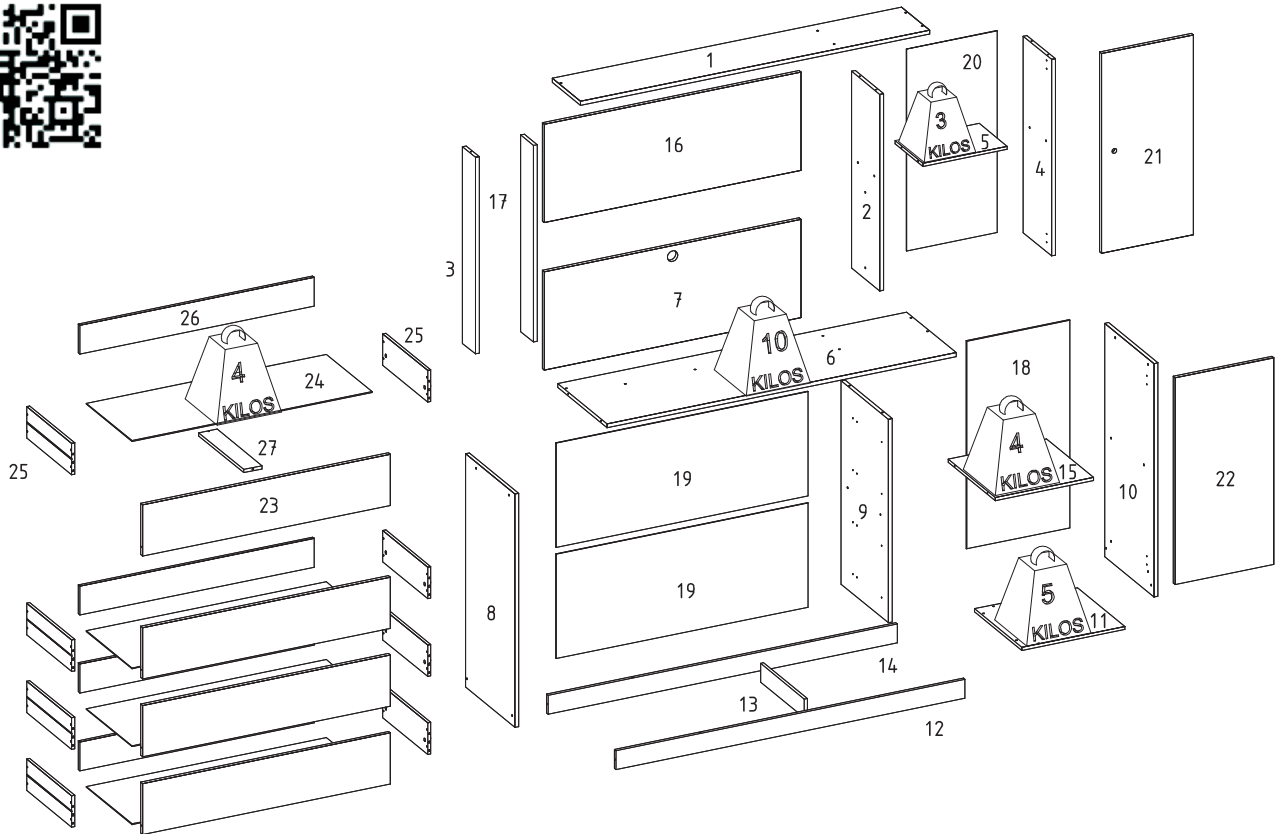



LISTA DE PEÇAS / Pieces List / Lista de Piezas

SEQ.	REF.	DESCRIÇÃO	DESCRIPTION	DESCRIPCIÓN	MAT.PRIMA	COMP.	LARG.	ESP.	QTD.
1	318187	Chapéu	Hat	Sombrero	MDP	1360	220	15	1
2	318188	Divisória nicho	Niche partition	Partición de nicho	MDP	750	220	15	1
3	318189	Lateral esquerda painel	Left side panel	Panel lateral izquierdo	MDP	750	100	15	1
4	318190	Lateral direita nicho	Right side niche	Nicho del lado derecho	MDP	750	220	15	1
5	318191	Prateleira nicho	Niche shelf	Estante de nicho	MDP	328	218	12	1
6	318192	Tampo	Cover	Tablero de la mesa	MDP	1360	385	15	1
7	318193	Painel frontal inferior	Lower front panel	Panel frontal inferior	MDP	1000	375	15	1
8	318194	Lateral esquerda	Left-back	Espalda izquierda	MDP	890	385	15	1
9	318195	Divisória	Partition	Partición	MDP	776	367	15	1
10	318196	Lateral direita	Right side	Derecho	MDP	890	385	15	1
11	318197	Base	Base	Base	MDP	401	369	12	1
12	318198	Rodapé frontal	Front footer	Pie de página	MDP	1360	72	12	1
13	318199	Trava rodapé	Footer lock	Bloqueo de pie de página	MDP	340	72	12	1
14	318200	Rodapé traseiro	Rear footer	Pie de página trasero	MDP	1360	72	12	1
15	318201	Prateleira inferior	Bottom shelf	Estante inferior	MDP	383	367	12	1
16	318202	Painel frontal superior	Top front panel	Panel frontal superior	MDP	1000	375	15	1
17	318203	Trava painel	Panel lock	Bloqueo del panel	MDP	750	100	15	1
18	318204	Fundo porta inferior	Bottom door bottom	Parte inferior de la puerta inferior	HDF	792	402	3	1
19	318205	Fundo gaveteiro	Chest of drawers	Cajonera	HDF	981	398	3	2
20	318206	Fundo porta superior	Top door background	Fondo de la puerta superior	HDF	769	352	3	1
21	318207	Porta nicho	Niche door	Puerta de nicho	MDP	762	358	15	1
22	318208	Porta inferior	Bottom door	Puerta inferior	MDP	788	384	15	1
23	318209	Frente gaveta	Drawer front	Frente del cajón	MDP	965	195	15	4
24	318210	Fundo gaveta	Drawer bottom	Fondo del cajón	HDF	935	355	3	4
25	700488	Lateral gaveta	Side drawer	Cajón lateral	MDP	350	120	12	8
26	318212	Contra fundo	Against background	Contra el fondo	MDP	913	110	12	4
27	318213	Apoio de gaveta	Drawer support	Soporte de cajones	MDP	350	72	12	4

INSTRUÇÃO MONTAGEM PRODUTO

Instruções to Assembly / Instrucciones de montaje



Separe as peças e acessórios de maneira organizada
Separate parts and accessories in way organized
Separe las piezas y accesorios de manera organizada



Forrar o chão com o papelão das embalagens.
Cover the floor with the cardboard
Cubra el suelo con la embalaje de cartón



É necessário 01 pessoa para montar o produto
It is necessary one person to assembly
Es necesario una persona para ensamblar

O produto deve ser a montado por um profissional qualificado
The product must be assembly by a professional
El producto debe ser ensamblado por un profesional calificado

Ferramentas necessárias
(não fornecidas)
Not include tools / No herramientas



CUIDADO PARA CONSERVAÇÃO E LIMPEZA DO MÓVEL

Care to conservation and clean / Cuidados de limpieza

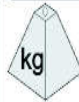

O peso máximo de carga informado refere-se a objetos distribuído de maneira uniforme sobre toda área de contato da peça
Set maximum weight load refers to objects distributed uniformly over the entire contact area of the workpiece.
Conjunto de carga máxima de peso se refiere a objetos distribuidos uniformemente sobre toda el área de contacto de la pieza de trabajo.



Não molhar o móvel e não expor em lugar úmido
Do not wet the mobile and do not expose in a wet place
No moje el producto y no exponer en un lugar húmedo



Não expor o móvel próximo de fontes de calor.
Do not expose the mobile near heat sources
no exponga cercano de fuentes de calor



Não usar produtos abrasivos.
Do not use abrasive products.
No utilice productos abrasivos.



Limpe com flanela limpa e seca.
Clean with dry cloth
Limpieza con un paño limpio y seco

LISTA DE ACESSÓRIOS E FERRAGEM / ACCESSORIES AND HARDWARE / ACCESORIOS Y EQUIPOS



A- 700137-Parafuso 4,5x45 (39x)
screw / tornillo



B- 700124-Parafuso 3,5x25 (30x)
screw / tornillo



C- 700121-Parafuso 3,5x12 (196x)
screw / tornillo



D- 700148-Tambor Minifix (8x)
Minifix Drum /
Tambor minifix



E- 700146-Parafuso minifix (8x)
Minifix screw /
Tornillo minifix



F- 700542-Cavilha 6x30 (22x)
peg / cerrojo



G- 700539-Cantoneira (21x)
corner / esquina



H- 700157-Prego (83x)
nail / clavo



I - 700113-Corredieça (4x)
runners / corredera



J- 700489-Perfil H (1x)
Frame / Perfil



K- 700547-Junção (5x)
junction / juncion



L- 700127-Parafuso 4,0x12 (32x)
screw / tornillo



M- 700419-Tapa furo minifix (41x)
Minifix cover / Tapa minifix



N- 700171-Puxador 250 mm (5x)
Handle / Manija



O - 700490-Kit com 6 Pes (1x)
foot / pie



P- 700443-Tampa passa fio (1x)
Cover / Cubrir

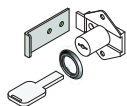

Q - 700286-Kit Fechadura (1x)
700537-Batente fechadura(1x)
Lock Kit/Kit de bloqueio



R - 700546-Chapa União 4 furos (4x)
Union plate 4 holes/Placa de unión 4 agujeros



S - 700565-Batente de Silicone (1x)
Silicone Stop/Parada de silicona



T - 700485-Espelho (1X)
Mirror/Espejo



U-700396-Dobradiça baixa (2x)
700389-Calço 3mm (2x)
Shim, Hinge/ Calce, Bisagra

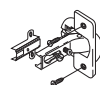

V- 700395-Dobradiça Alta (2x)
700391-Calço 12mm (2x)
Shim, Hinge/ Calce, Bisagra



W- 700516-Cola (1x)
glue / pegamento

01° PASSO Fixar peças 2 , 3 e 4 na peça 1 . Fixar peça 5 nas peças 2 e 4

01° STEP Attach parts 2, 3, and 4 to part 1. Attach part 5 to parts 2 and 4

01° PASO Adjunte las partes 2, 3 y 4 a la parte 1. Adjunte la parte 5 a las partes 2 y 4

A

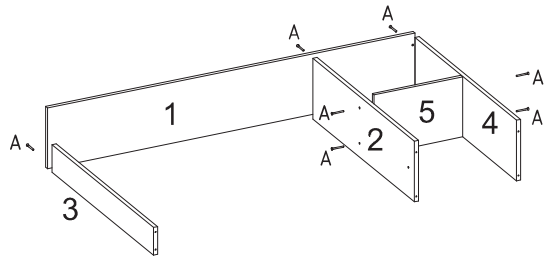

02° PASSO Fixar peças 2 , 3 e 4 na peça 6 . Fixar peça 7 na peça 2

02° STEP Attach parts 2, 3 and 4 to part 6. Attach part 7 to part 2

02° PASO Adjunte las partes 2, 3 y 4 a la parte 6. Adjunte la parte 7 a la parte 2

A

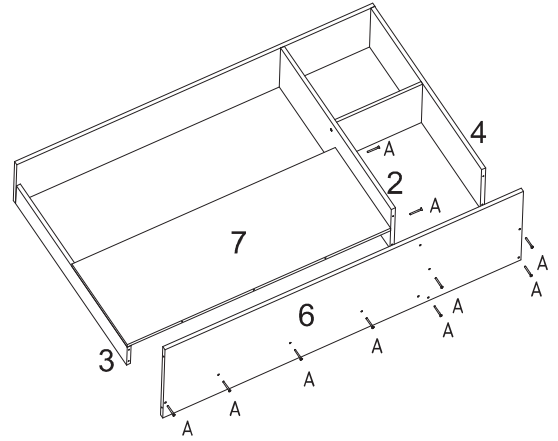

03° PASSO Fixar peças 8 , 9 e 10 na peça 6 . Fixar peça 11 nas peças 9 e 10

03° STEP Attach parts 8, 9 and 10 to part 6. Attach part 11 to parts 9 and 10

03° PASO Adjunte las partes 8, 9 y 10 a la parte 6. Adjunte la parte 11 a las partes 9 y 10

A



C



G

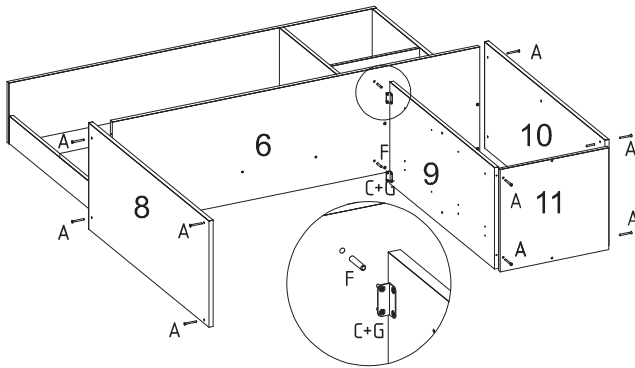

04° PASSO Fixar peças 12 , 13 e 14 nas peças 8 e 10 . fixar peça 15 nas peças 9 e 10

04° STEP Attach pieces 12, 13 and 14 to pieces 8 and 10. fix piece 15 on pieces 9 and 10

04° PASO Adjunte las piezas 12, 13 y 14 a las piezas 8 y 10. arreglar la pieza 15 en las piezas 9 y 10

A



O

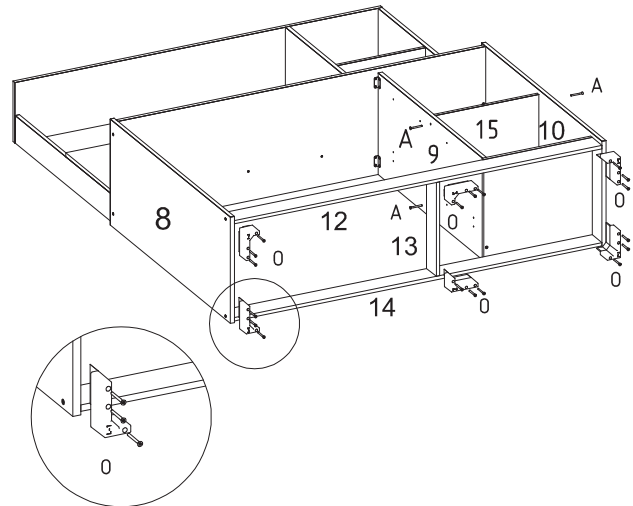

05° PASSO Fixar peças 16 e 17 utilizando os acessórios (C+G+R)

05° STEP Secure parts 16 and 17 using attachments (C + G + R)

05° PASO Asegure las piezas 16 y 17 con accesorios (C + G + R)

C



G



I



R

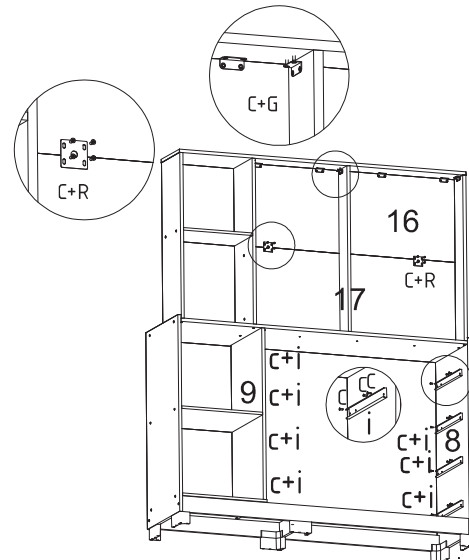

06° PASSO Fixar peças 18 , 19 e 20 no produto utilizando os acessórios (F+J+K)

06° STEP Secure parts 18 and 19 using attachments (C + G + R)

06° PASO Asegure las piezas 16 y 17 con accesorios (C + G + R)

H



K



J

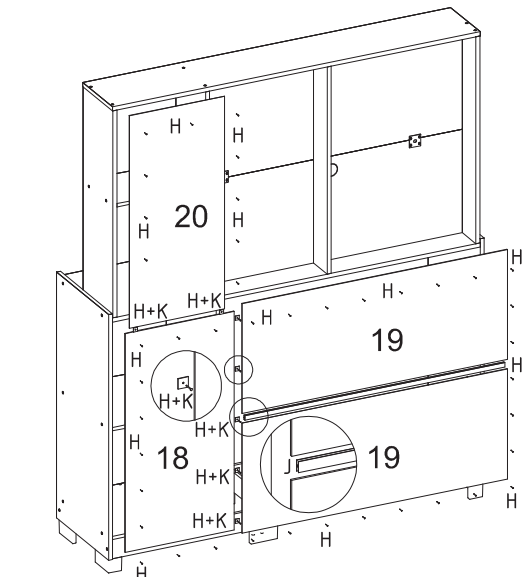

07° PASSO Fixar os acessórios (T e Q) na peça 21

07° STEP Attach accessories (T and Q) to part 21

07° PASO Conecte los accesorios (T y Q) a la parte 21

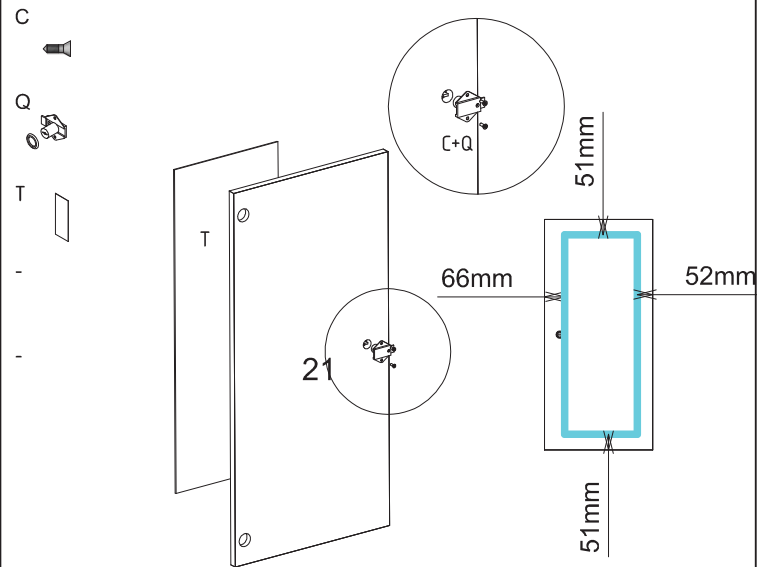

08° PASSO Fixar peças 25 nas peças 23 e 26 . Fixar peças 24 e 27 nas peças 23 , 25 e 26

08° STEP Attach pieces 25 to pieces 23 and 26. Attach parts 24 and 27 to parts 23, 25 and 26

08° PASO Adjunte las piezas 25 a las piezas 23 y 26. Adjunte las partes 24 y 27 a las partes 23, 25 y 26

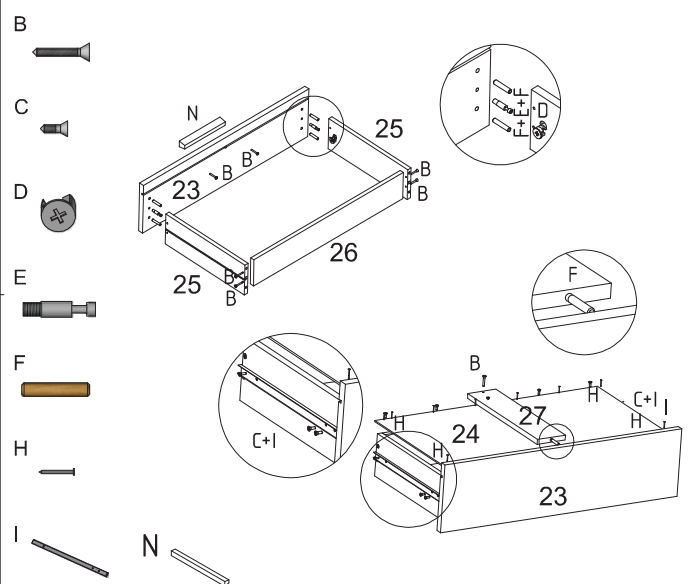

09° PASSO Fixar peça 21 na peça 4 . Fixar peça 22 na peça 10

09° STEP Attach part 21 to part 4. Attach part 22 to part 10

09° PASO Adjunte la parte 21 a la parte 4. Adjunte la parte 22 a la parte 10

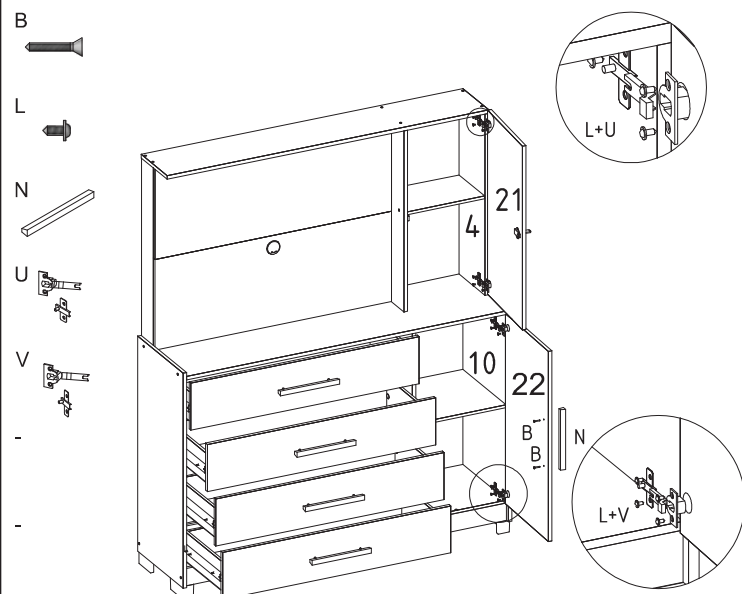

10° PASSO Fixar acessórios (P e S) no produto

10° STEP Attach accessories (P and S) to product

10° PASO Adjunte accesorios (P y S) al producto

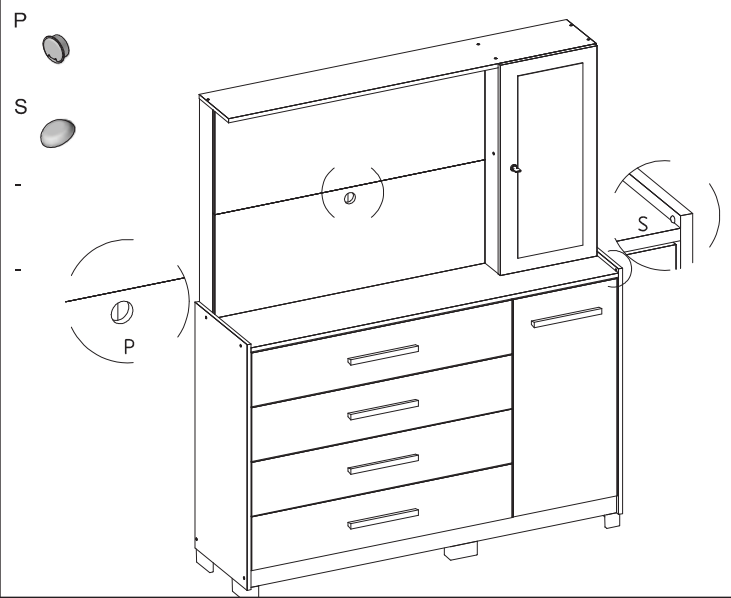

11° PASSO -

11° STEP -

11° PASO -

12° PASSO Aspecto final do produto

12° STEP Final product aspect

12° PASO Aspecto final del producto

