

# ASSEMBLY INSTRUCTIONS MANUAL DE MONTAGEM / INSTRUCCIONES DE ARMADO

TOP 47 1/4"  
TAMPO 1200MM  
TAMPA 1200MM

Reference  
Referência  
Referencia **240542** | Revise  
| Revisão  
| Revisión **00**

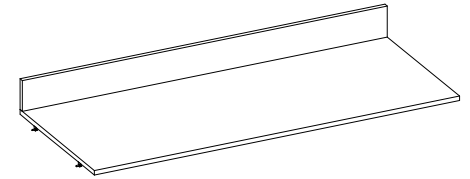

**YOU WILL NEED  
VOCÊ VAI PRECISAR DE / USTED NECESITARÁ**

Tools not supplied  
Ferramentas não fornecidas / Herramientas no incluidas

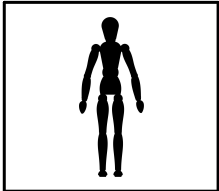

1 Person  
1 Pessoa  
1 Persona

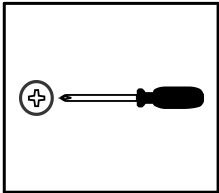

Screwdriver Phillips  
Chave Phillips  
Destornillador cruz

**PARTS IDENTIFICATION  
IDENTIFICAÇÃO DAS PEÇAS / IDENTIFICACIÓN DE LAS PIEZAS**

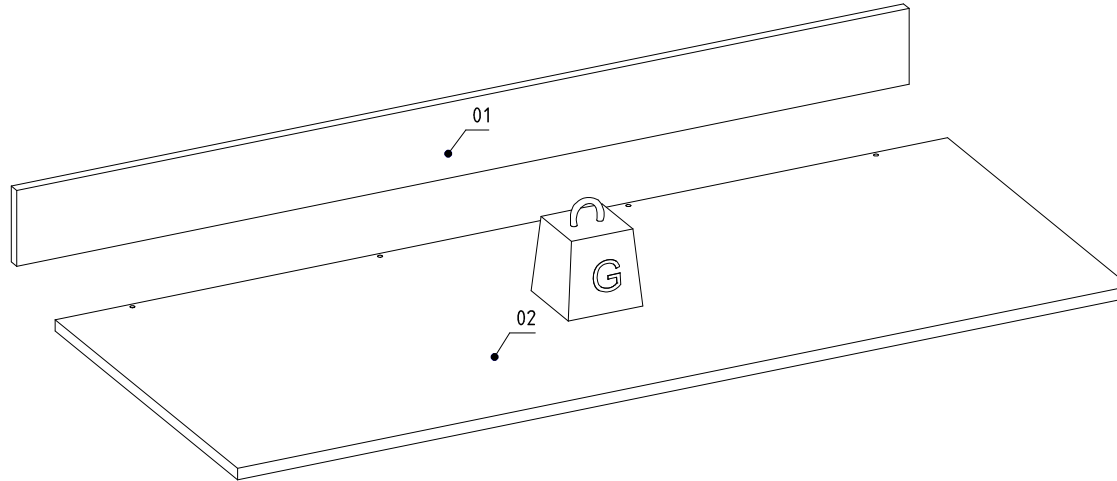

Nº	Measures_Inches	Medidas_cm	Qty./Qtd.
01	47 1/4 x 3 7/8 x 5/8	120.0 x 10.0 x 1.5	1
02	47 1/4 x 19 1/4 x 5/8	120.0 x 49.0 x 1.5	1



MAXIMUM RECOMMENDED WEIGHT  
BEING THIS EVENLY DISTRIBUTED.

PESO MÁXIMO RECOMENDADO SENDO  
ESTE DISTRIBUÍDO UNIFORMEMENTE.

PESO MÁXIMO RECOMENDADO SIENDO  
ESTE UNIFORMEMENTE DISTRIBUIDO.

	LB	KG
G	33	15

## IDENTIFICATION OF ACCESSORIES IDENTIFICAÇÃO DOS ACESSÓRIOS/ IDENTIFICACIÓN DE ACCESORIOS



The separation of the accessories before you start the assembly will facilitate the same. In case of doubt on the size of the screws and bolts, use the ruler to bottom of page.  
 A separação dos acessórios antes de iniciar a montagem facilitará a mesma. Em caso de dúvida no tamanho dos parafusos e cavilhas, utilize a régua ao final da página.  
 La separación de los accesorios antes de comenzar el armado facilitará el mismo. En caso de duda sobre el tamaño de los tornillos y taquetes, utilice la regla al pie de página.

D		Flat head screw Parafuso chato / Tornillo de cabeza plana	4,0x40 mm	4
S		Pan head screw Parafuso panela / Tornillo de pan	3,5x14 mm	8
Y18		Zamac bracket Cantoneira zamac/ Suporte de zamac	13x13 mm	4

## PRE-ASSEMBLE PRÉ-MONTAGEM / PRE ARMADO

01

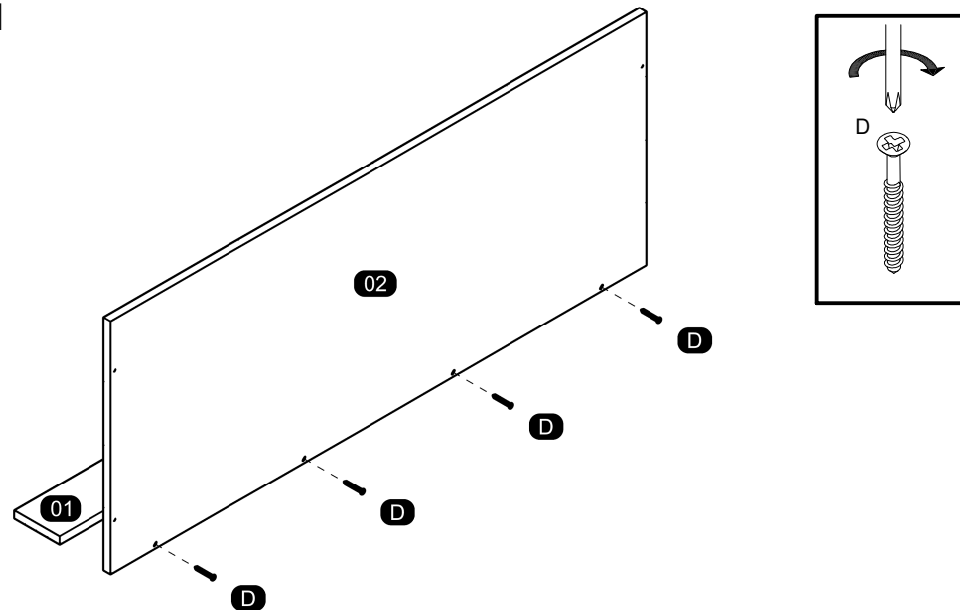

02

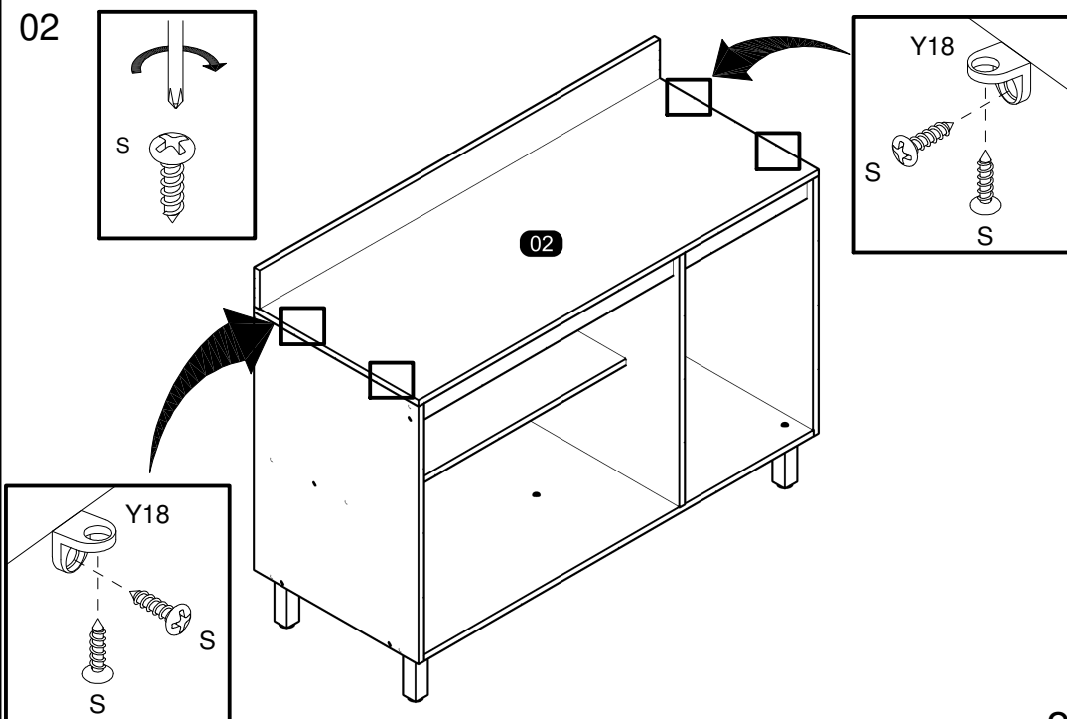

# ASSEMBLY INSTRUCTIONS MANUAL DE MONTAGEM / INSTRUCCIONES DE ARMADO

CABINET 2 DOORS 3 DRAWERS  
BALCÃO 2P 3G  
GABINETE 2 PUERTAS 3 CAJONES

Reference  
Referência  
Referencia **240603** | Revise  
| Revisão  
| Revisión **00**

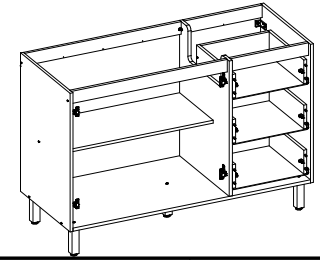

**YOU WILL NEED  
VOCÊ VAI PRECISAR DE / USTED NECESITARÁ**

Tools not supplied  
Ferramentas não fornecidas / Herramientas no incluidas

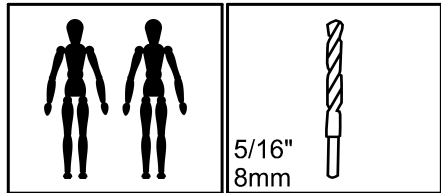

2 People  
2 Pessoas  
2 Personas

Drill bit  
Broca  
Taladro

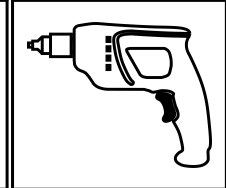
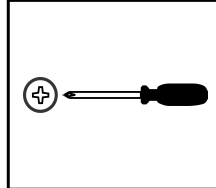

Screwdriver Phillips  
Chave Phillips  
Destornillador cruz

Drill machine  
Furadeira  
Taladro

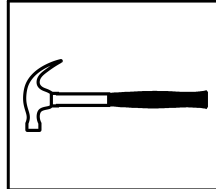

Hammer  
Martelo  
Martillo

**MAXIMUM RECOMMENDED WEIGHT  
BEING THIS EVENLY DISTRIBUTED.**  
**PESO MÁXIMO RECOMENDADO SENDO  
ESTE DISTRIBUÍDO UNIFORMEMENTE.**  
**PESO MÁXIMO RECOMENDADO SIENDO  
ESTE UNIFORMEMENTE DISTRIBUIDO.**

	LB	KG
C	6	3
D	11	5
F	22	10

**PARTS IDENTIFICATION  
IDENTIFICAÇÃO DAS PEÇAS / IDENTIFICACIÓN DE LAS PIEZAS**

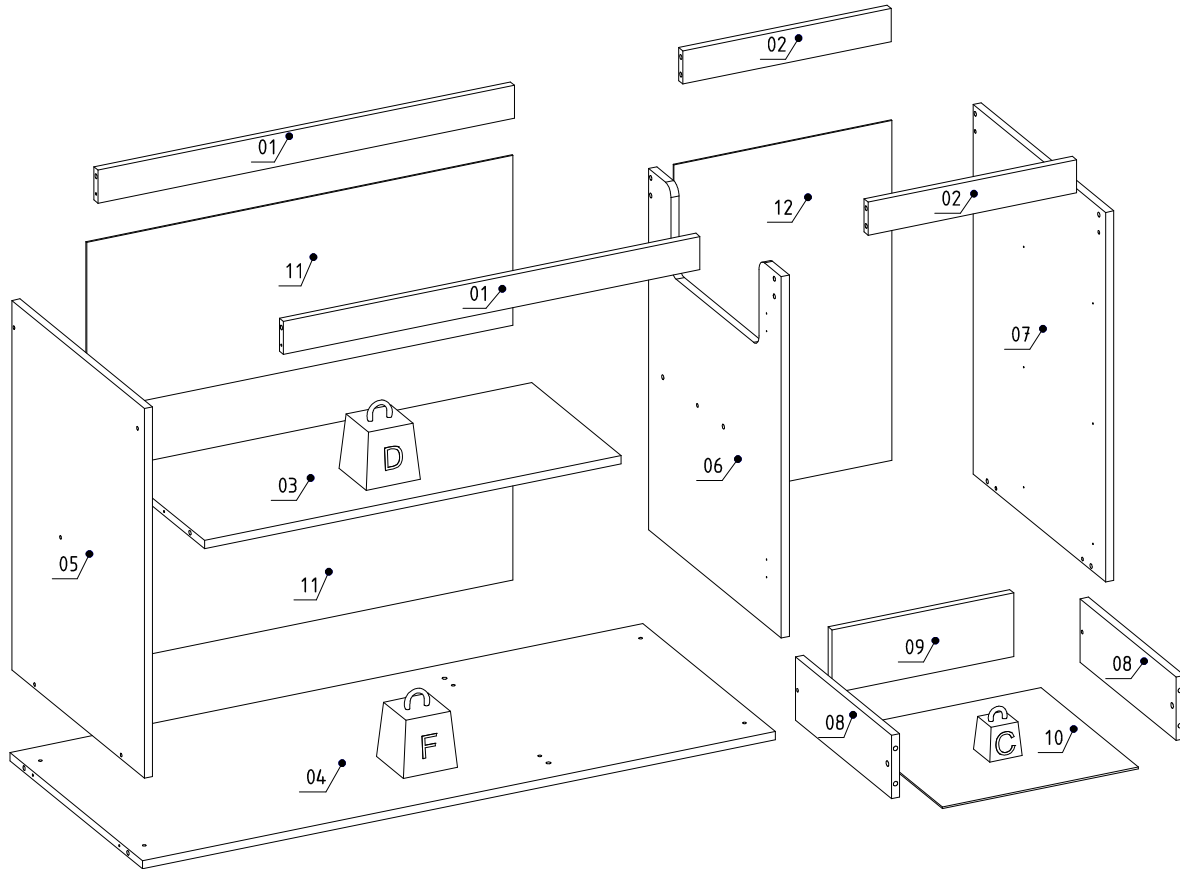

Nº	Measures_Inches	Medidas_cm	Qty./Qtd.
01	30 3/8 x 2 3/8 x 5/8	77.0 x 6.0 x 1.5	2
02	15 1/8 x 2 3/8 x 5/8	38.5 x 6.0 x 1.5	2
03	30 3/8 x 13 x 5/8	77.0 x 33.0 x 1.5	1
04	46 1/8 x 19 1/4 x 5/8	117.0 x 49.0 x 1.5	1
05	26 3/8 x 19 1/4 x 5/8	67.0 x 49.0 x 1.5	1
06	25 3/4 x 19 1/4 x 5/8	65.5 x 49.0 x 1.5	1
07	26 3/8 x 19 1/4 x 5/8	67.0 x 49.0 x 1.5	1
08	14 x 4 1/2 x 5/8	35.5 x 11.5 x 1.5	6
09	13 1/4 x 4 1/2 x 5/8	33.6 x 11.5 x 1.5	3
10	14 1/4 x 14 1/8 x 1/8	36.2 x 36.0 x 0.3	3
11	31 x 12 1/8 x 1/8	78.8 x 30.8 x 0.3	2
12	24 1/4 x 15 7/8 x 1/8	61.6 x 40.3 x 0.3	1

## IDENTIFICATION OF ACCESSORIES IDENTIFICAÇÃO DOS ACESSÓRIOS/ IDENTIFICACIÓN DE ACCESORIOS



The separation of the accessories before you start the assembly will facilitate the same. In case of doubt on the size of the screws and bolts, use the ruler at the bottom of the page.  
 A separação dos acessórios antes de iniciar a montagem facilitará a mesma. Em caso de dúvida no tamanho dos parafusos e cavilhas, utilize a régua ao final da página.  
 La separación de los accesorios antes de comenzar el armado facilitará el mismo. En caso de duda sobre el tamaño de los tornillos y taquetes, utilice la regla al pie de página.

A		Flanged head screw Parafuso flangeado / Tornillo de cabeza flangeada	5,0x60 mm	2
A3		Trapeze Trapézio / Trapecio	-	6
A23		Foot Pé Quadrado FP / Pie	140 mm	5
B3		Bushing Bucha expansiva / Tapón	8x50 mm	2
C		Flanged head screw Parafuso flangeado / Tornillo de cabeza flangeada	4,5x45 mm	5
C1		Metal claw Garra de metal / Garra metal	-	8
D		Flat head screw Parafuso chato / Tornillo de cabeza plana	4,0x40 mm	6
D5		Hinge shim Calço dobradiça / Bisagra de calce	-	4
D6		Metal hinge super high Dobradiça super alta / Bisagra alta	26mm	4
E		Wooden dowel Cavilha / Taquete	8x30 mm	26
F		Wooden dowel Cavilha / Taquete	8x50 mm	4
L9		Flat head screw Parafuso chato / Tornillo de cabeza plana	3,5x12 mm	30
L17		Telescopic slide Corrediça telescópica / Corredera telescópica	350 mm	6
M		Bore patch adhesive Tapa furo adesivo / Tapones adhesivo	-	20
N		Nail Prego / Clavo	10x10	66
N5		Support "L" Suporte "L" / Soporte "L"	-	2
O		Flat head screw Parafuso chato / Tornillo de cabeza plana	4,5x45 mm	12
P		Pan head screw Parafuso panela / Tornillo de pan	4,5x25 mm	6
S		Pan head screw Parafuso panela / Tornillo de pan	3,5x14 mm	28
Y18		Zamac bracket Cantoneira zamac/ Suporte de zamac	13x13 mm	4



## PRE-ASSEMBLE PRÉ-MONTAGEM / PRE ARMADO

01

SEPARATE THE TWO PARTS OF THE METAL SLIDE TO THE ASSEMBLY FOLLOWING THE INSTRUCTIONS BELOW.  
 SEPARAR AS DUAS PARTES DA CORREDIÇA METÁLICA PARA A MONTAGEM SEGUINDO AS INSTRUÇÕES ABAIXO.  
 SEPARAR LAS DOS PARTES DE LA CORREDERA DE METAL PARA EL ARMADO Y SEGUIR LAS INSTRUCCIONES ABAJO.

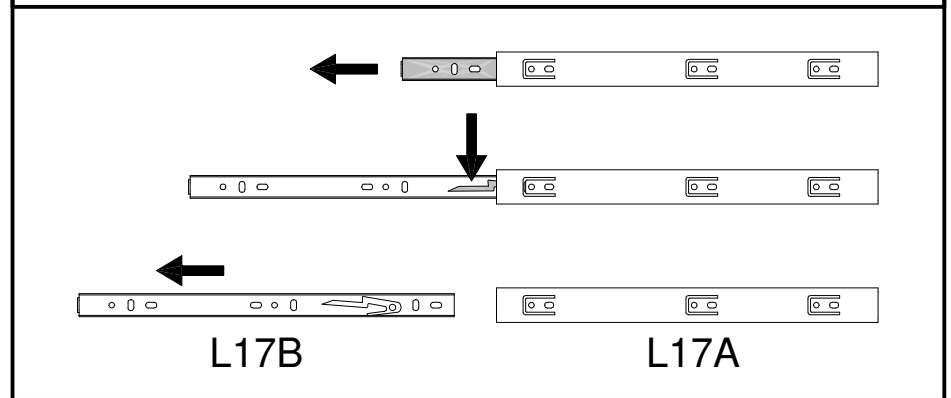

02

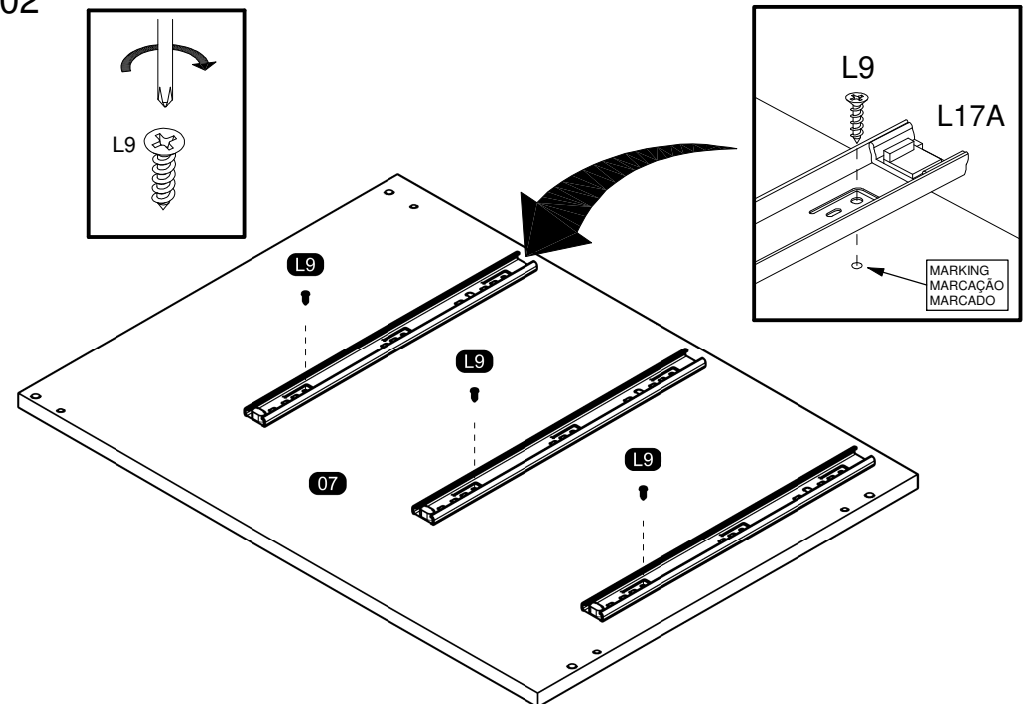

03

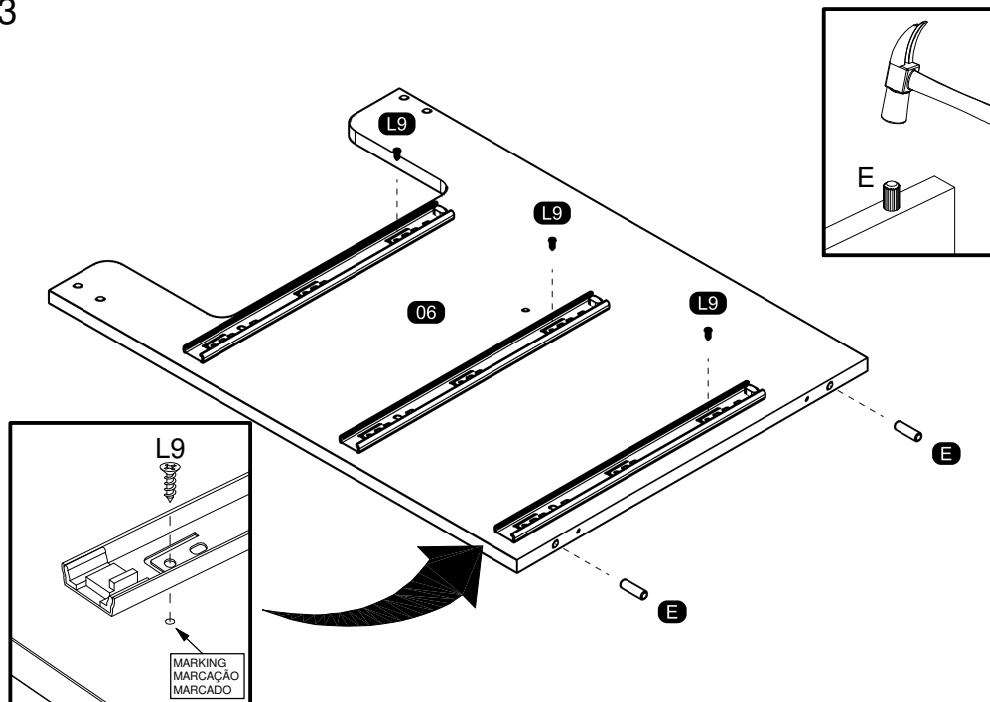

05

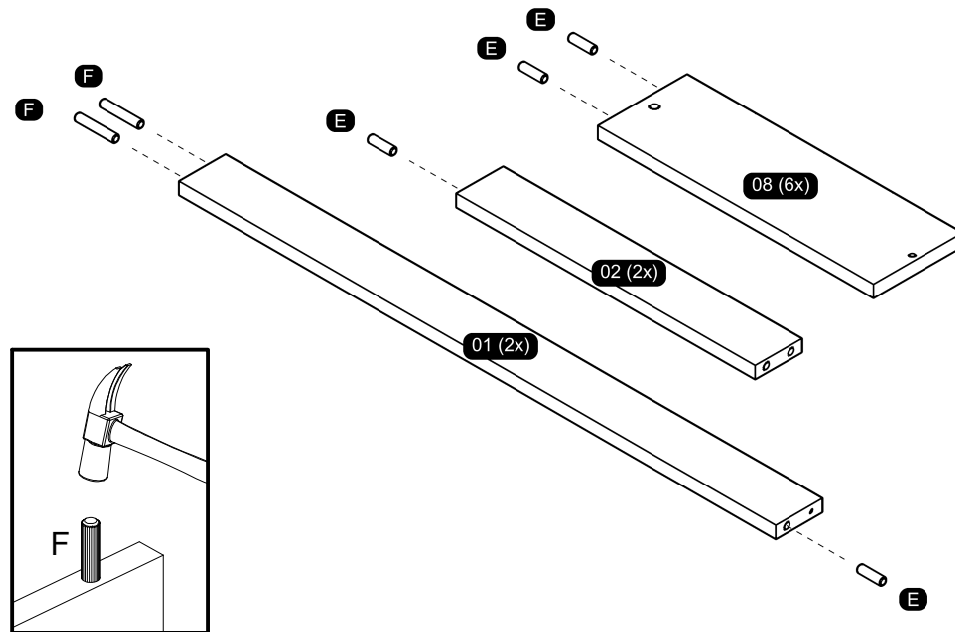

04

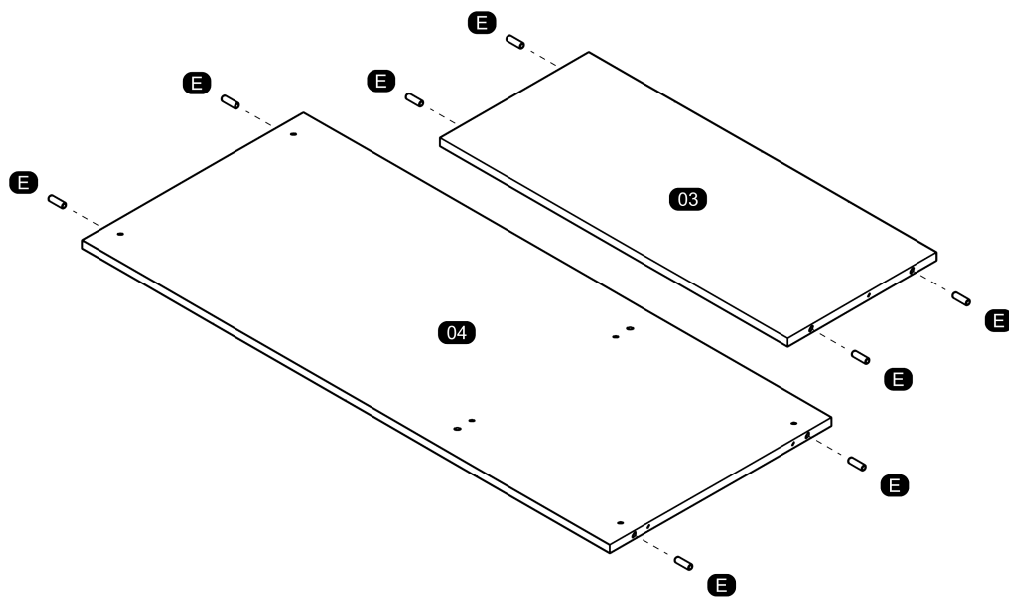

**ASSEMBLY  
MONTAGEM / ARMADO**

06

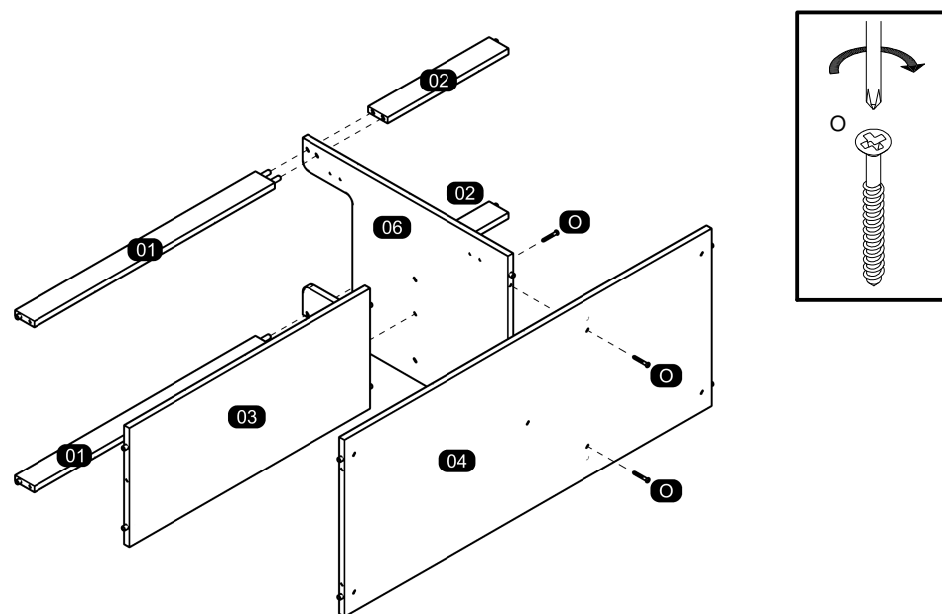

07

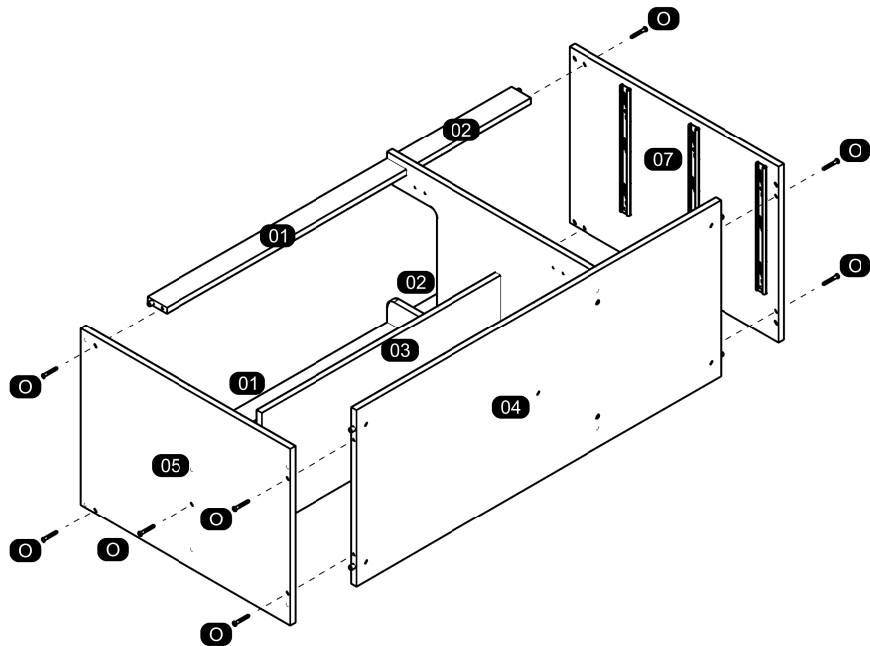

09

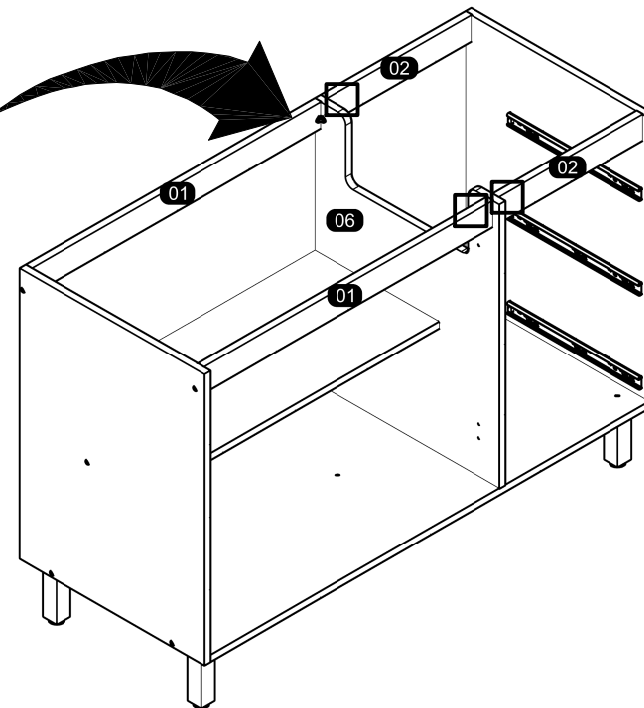
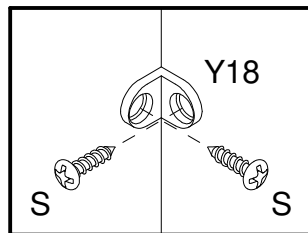

08

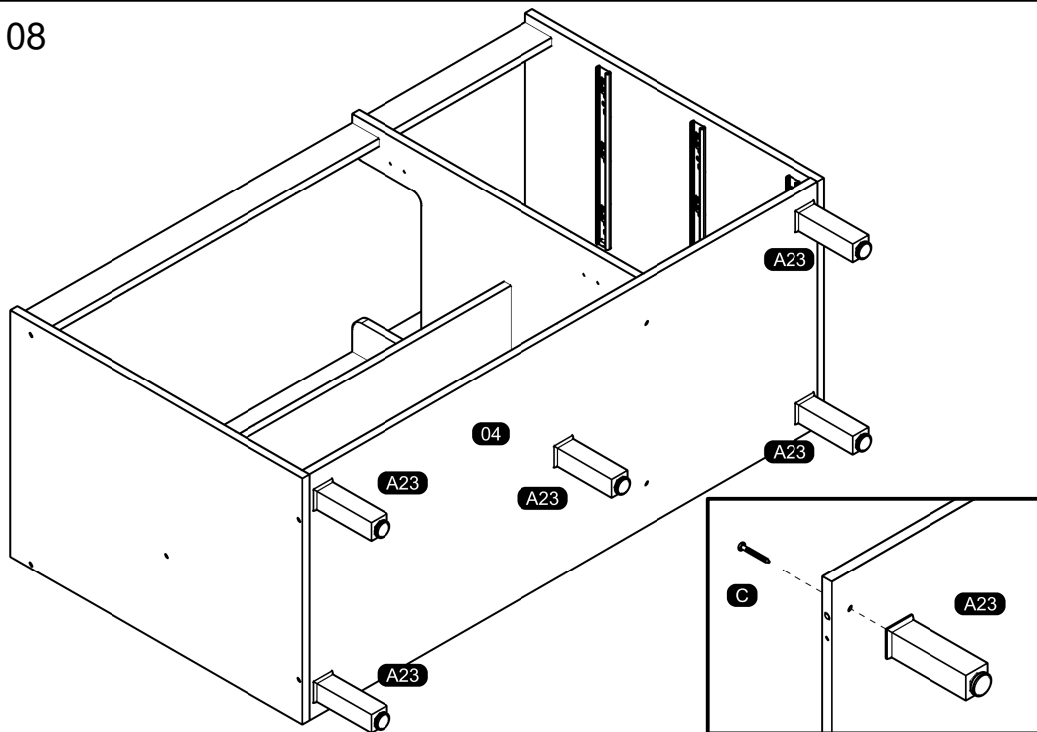

10

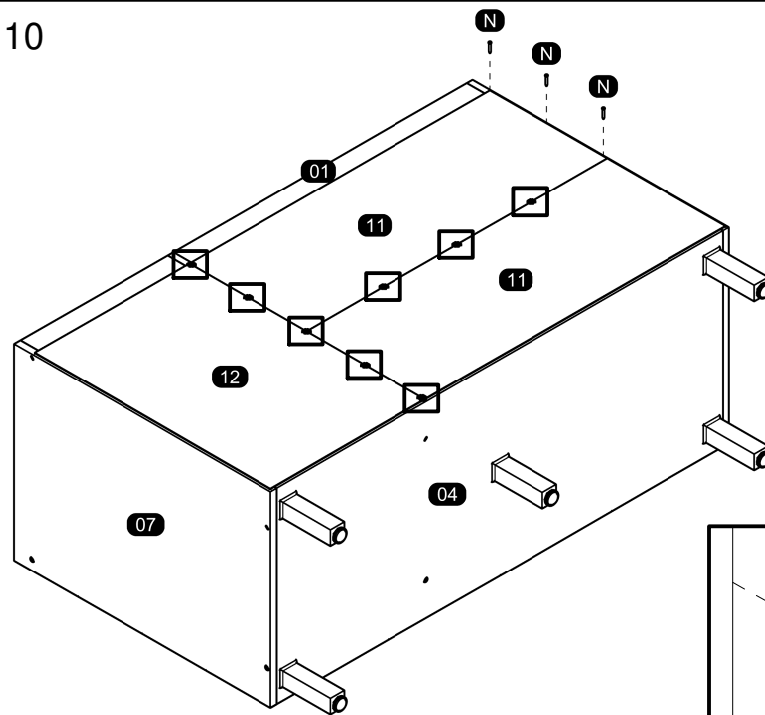

Furniture back  
 Parte traseira do móvel  
 Trasero del mueble

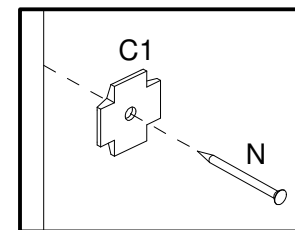
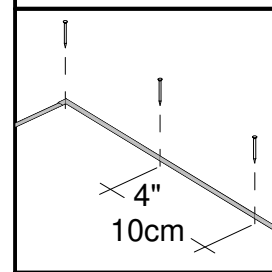

11

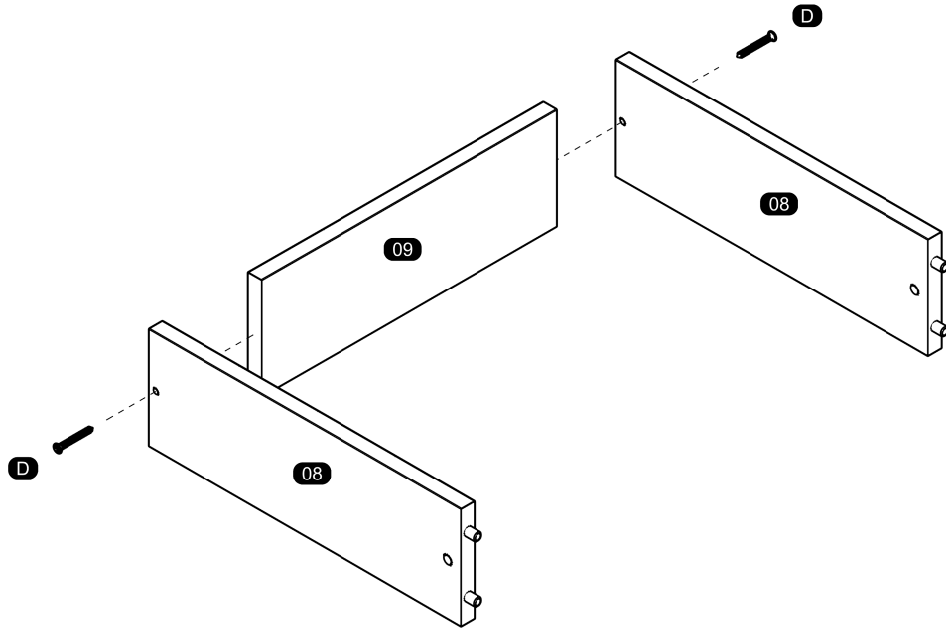

13

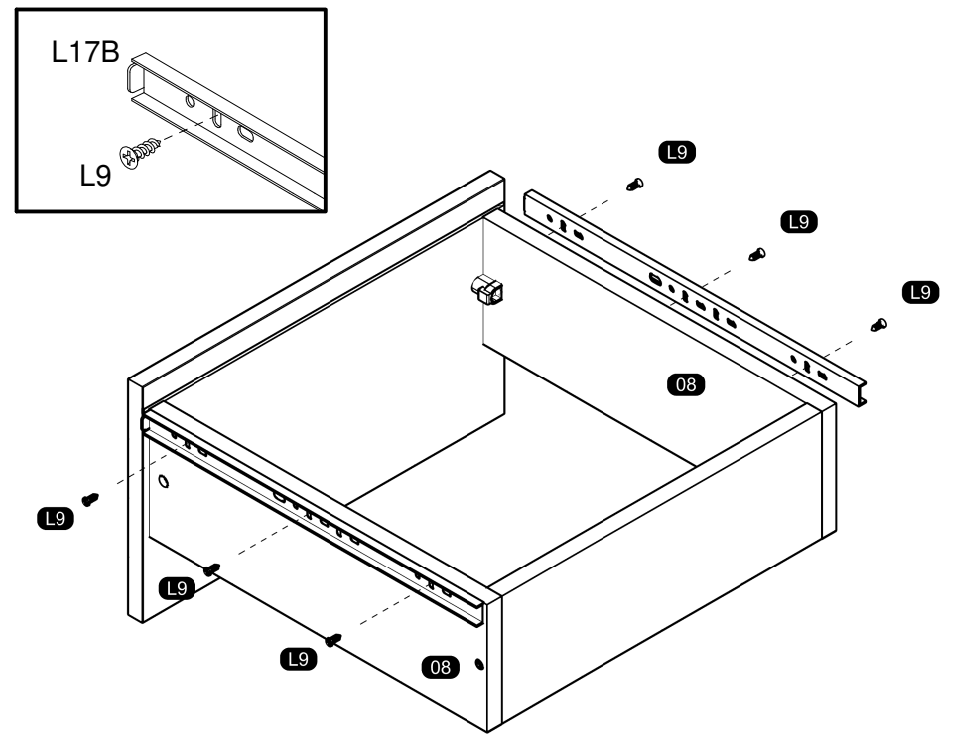

MOUNTING ON THE CHOSEN DRAWER FRONT MODEL  
 MONTAGEM NO MODELO DE FRENTE DE GAVETA ESCOLHIDO / MONTAJE EN EL MODELO DE FRENTE DE CAJÓN ELEGIDO

12

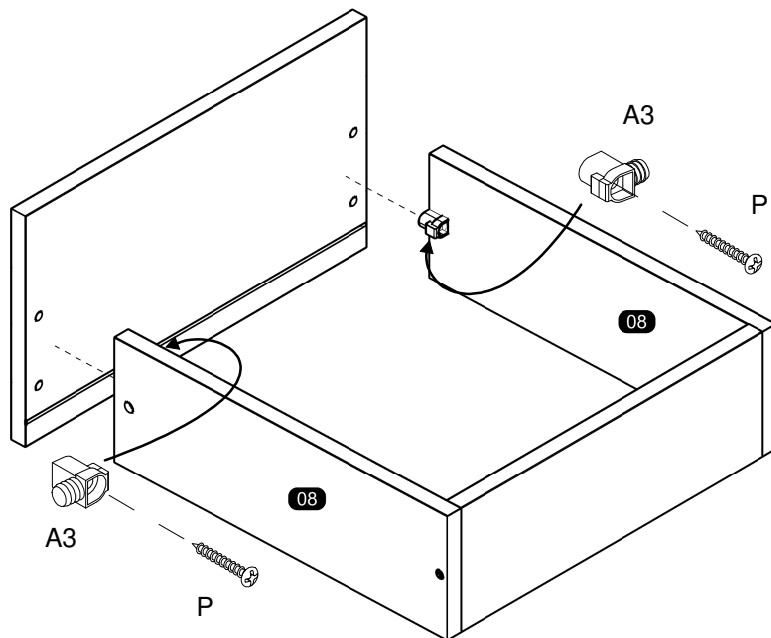

14

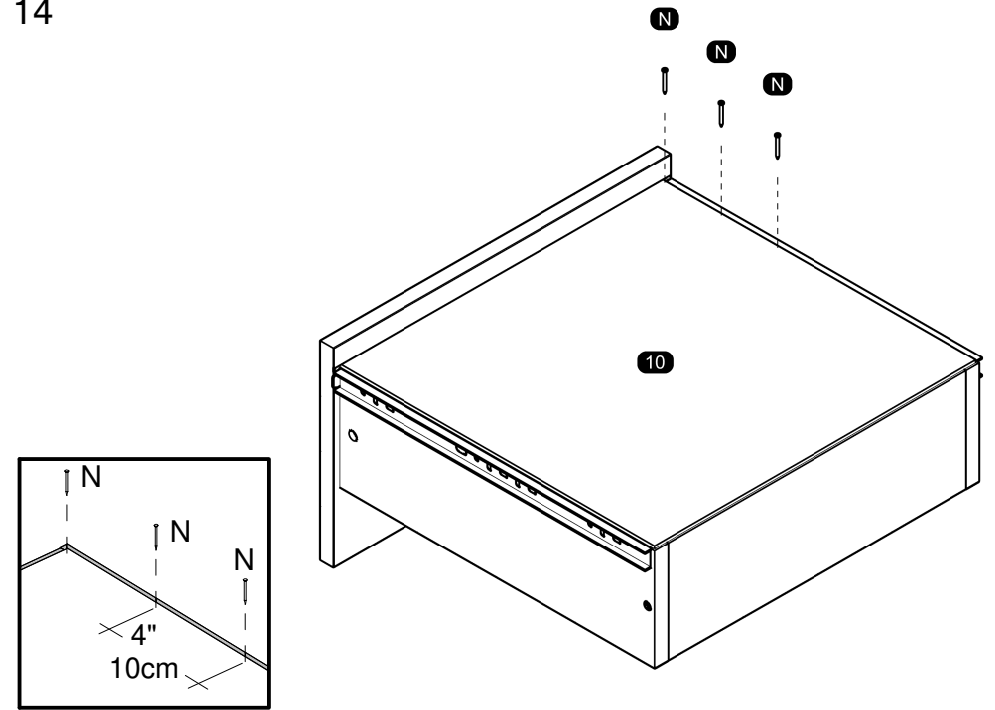

15

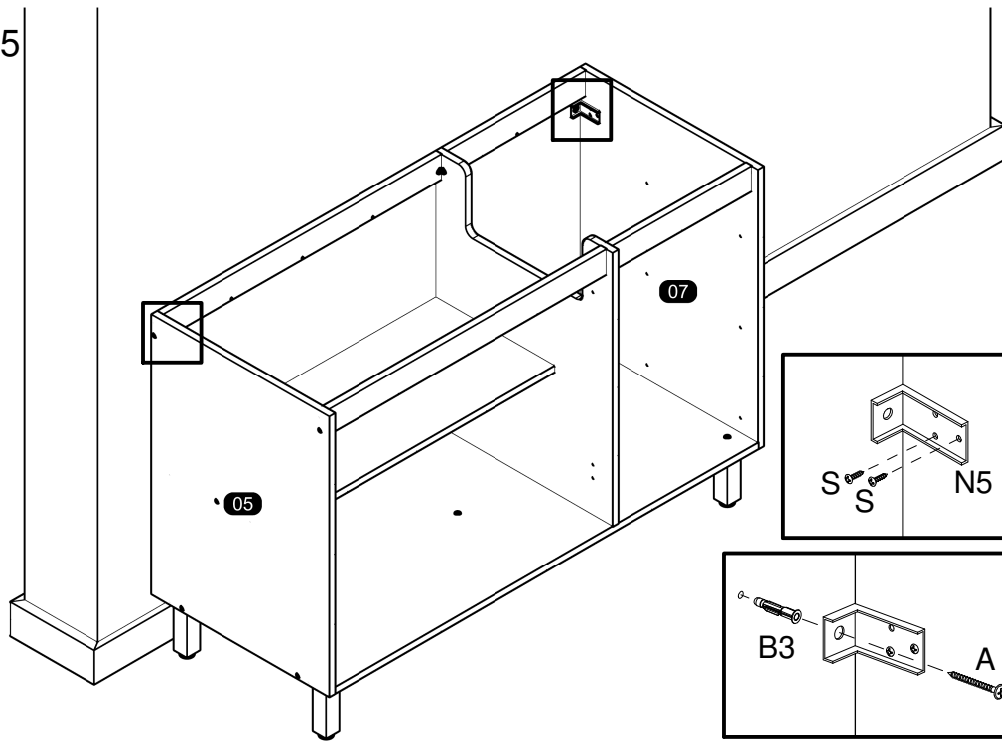

At the end of the assembly, insert the screw cover / hole plugs in the apparent holes.  
 Ao final da montagem, insira a(s) tampa(s) de parafuso / tapa furos nos furos que ficarem aparentes.  
 Al final del conjunto, coloque la tapa tornillo / tapón plástico en los agujeros que se hagan evidentes.

17

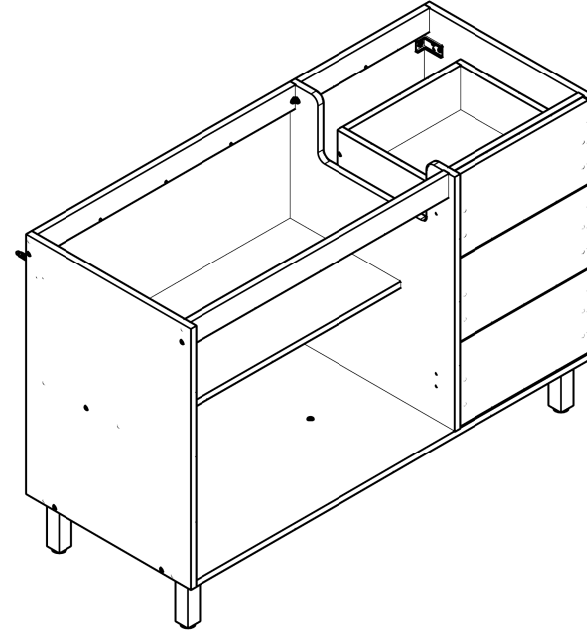

16

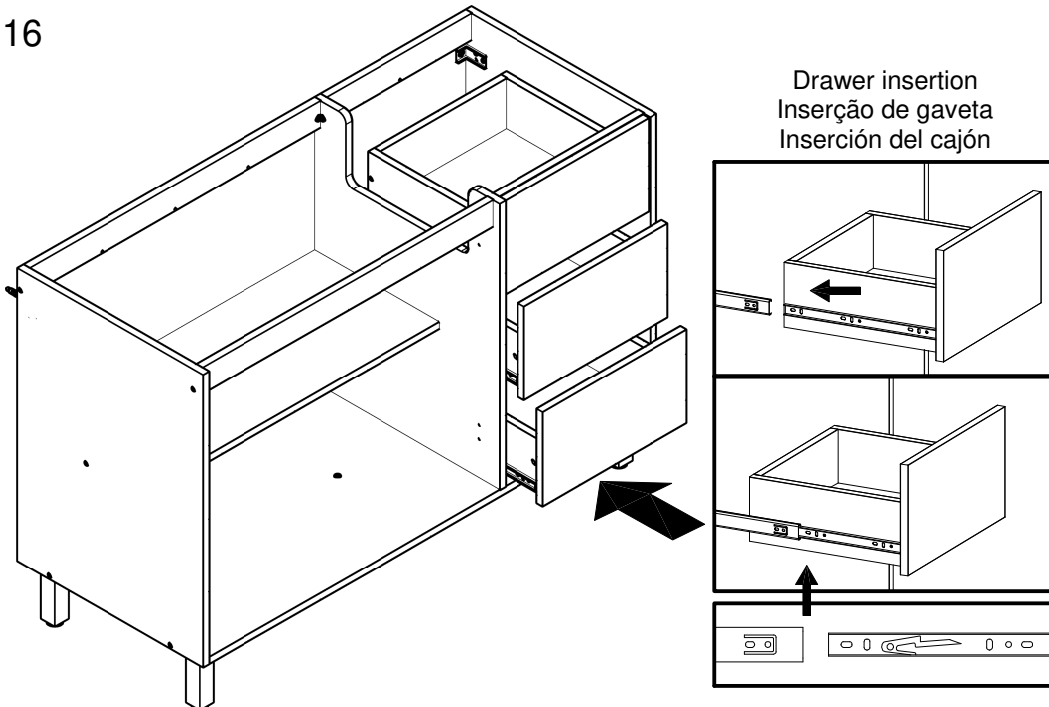

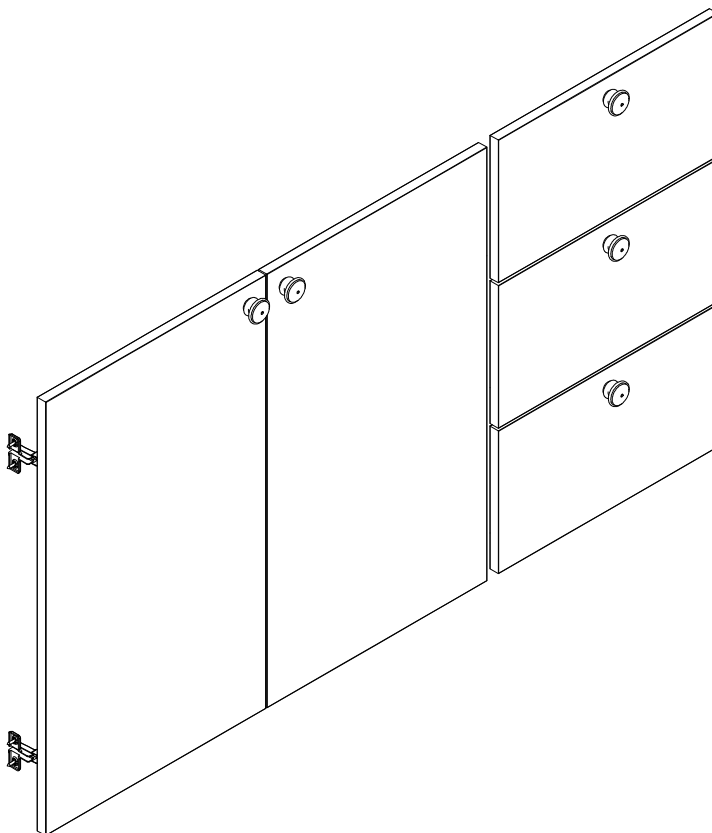

**Portas Lily Balcão 2P 3G**

## Como trocar seu produto

Se seu produto chegou com algum defeito você tem 7 dias para solicitar a troca. Você vai precisar:

- 1 Ter em mãos as fotos das peças com defeito; descrição; código (como está aqui no manual) e quantidade de peças com defeito.
- 2 Acesse o chat em nosso site.
- 3 Selecione o seu pedido, e depois a opção “Quero trocar um produto”.
- 4 Pronto, agora é só preencher as informações e enviar. Entraremos em contato por e-mail para te dar todas as instruções.

## Dicas para prolongar a vida útil do móvel

- 1 Retire o pó com uma flanela seca, depois use um pano macio, levemente umedecido com água. Pode utilizar detergente neutro ou sabão neutro.
- 2 Reaperte os parafusos de tempos em tempos para garantir a estabilidade e durabilidade.
- 3 O acabamento do seu produto pode ser danificado pela falta de ventilação e excesso de calor.

Qualquer dúvida sobre os nossos produtos você pode entrar em contato pelo nosso canal de atendimento:

**<https://www.madeiramadeira.com.br/central-de-ajuda>**

Para mais dicas amigas e inspirações de decoração acesse:  
**<https://www.madeiramadeira.com.br/central-de-dicas>**

**Siga MadeiraMadeira:**



Para a montagem do produto você vai precisar de:



- ✓ Confira as peças, componentes e se possui as ferramentas necessárias para a montagem.
- ✓ Para proteger seu móvel, coloque as peças sobre um tapete.
- ✓ Para realizar a montagem, é necessário 01 pessoas. Convide sua família e amigos para montar com você.

## LISTA DE FERRAGENS

REF	DESCRIÇÃO	ILUSTRAÇÃO	QTD.
A	Puxador pontual Italia		05
B	Parafuso Flangeado 3,5x25		05

# LISTA DE PEÇAS

Nº PEÇA	CÓD. IND.	DESCRIÇÃO	QTD	DIMENSÕES (mm)			PESO KG
				COMP.	LARG.	ESP.	
50	240661-50	PORTA ESQUERDA	01	650	381	15	2,41
51	240661-51	PORTA DIREITA	01	650	381	15	2,41
52	240661-52	FRENTE DE GAVETA	03	380	214	15	0,79

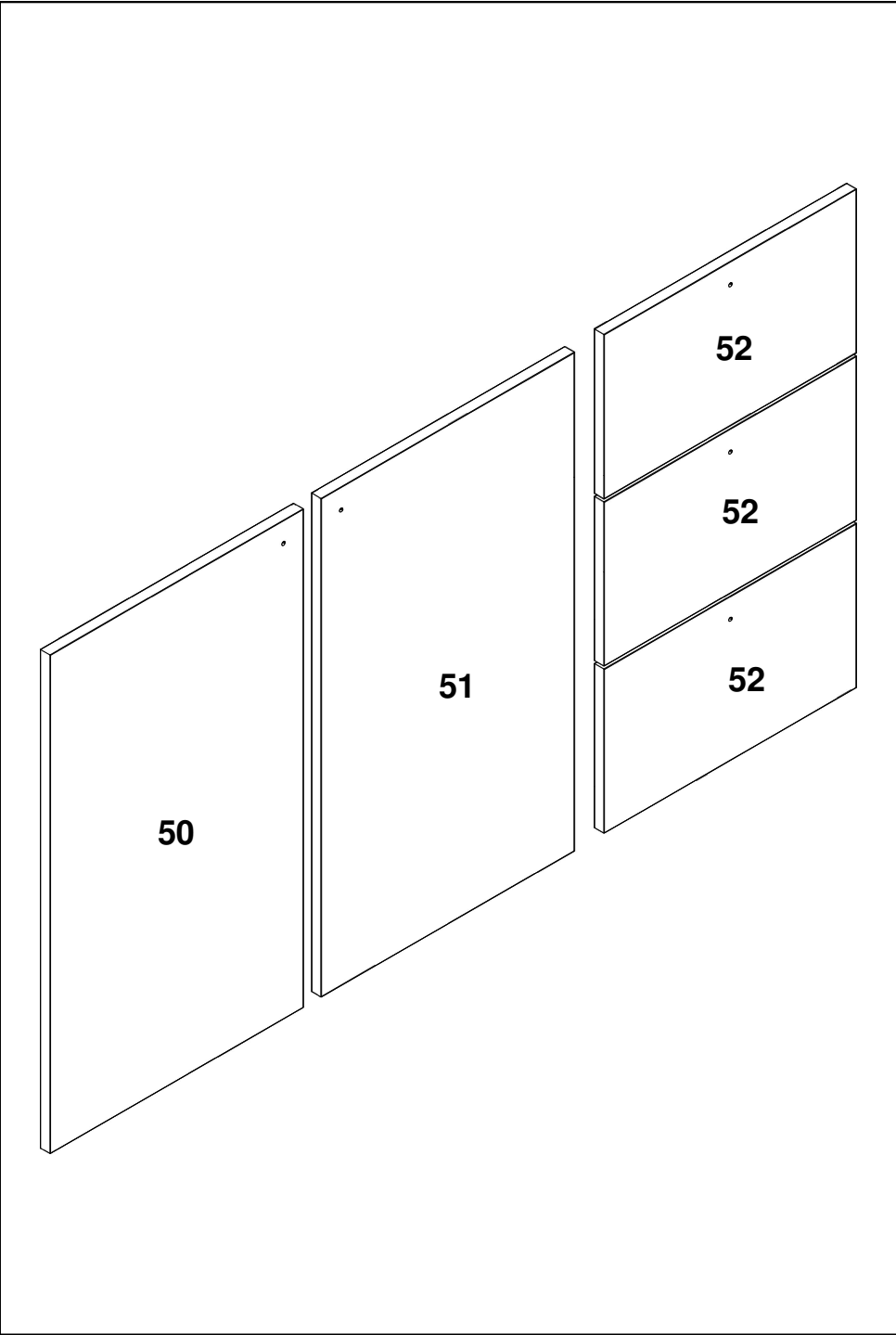

1

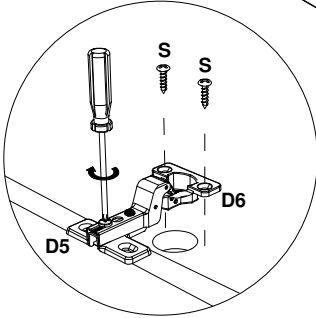
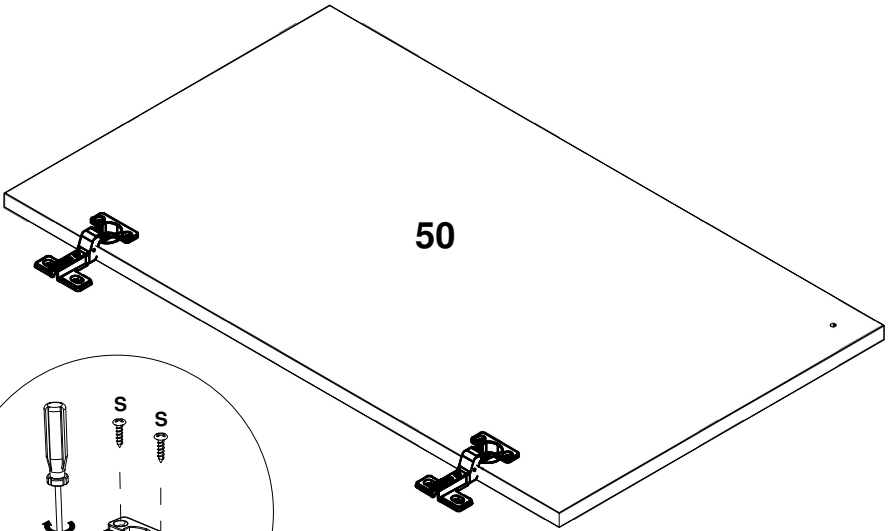

2

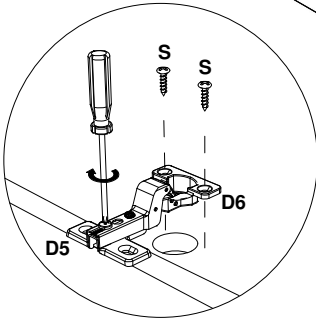
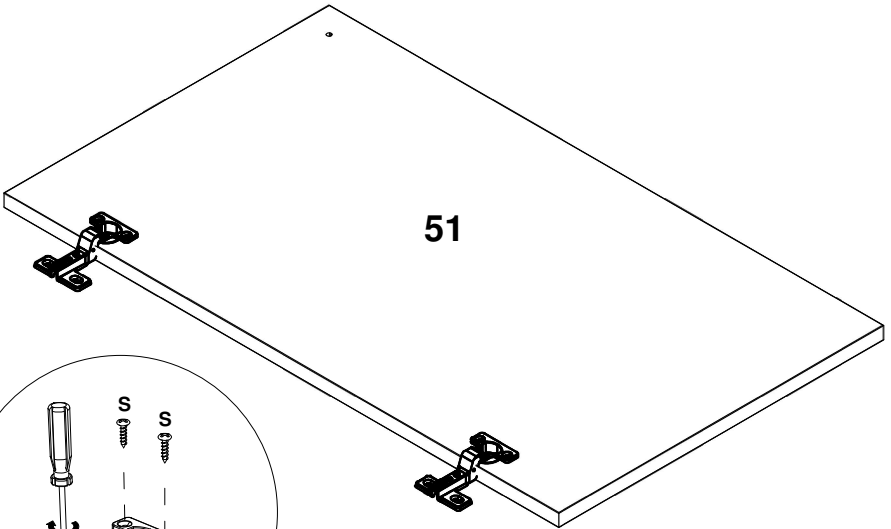

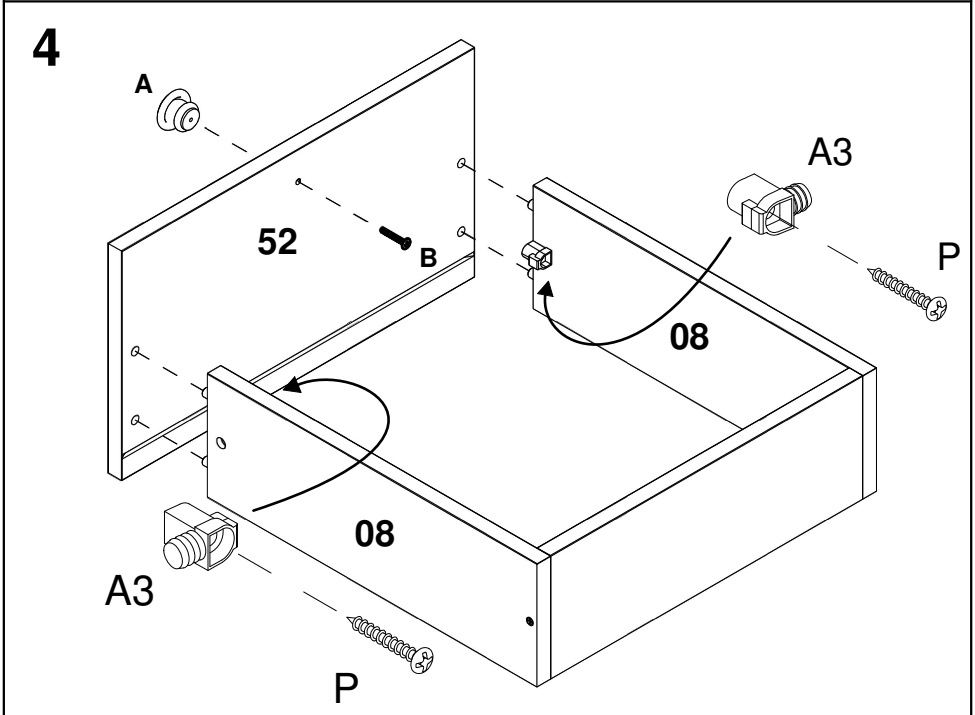
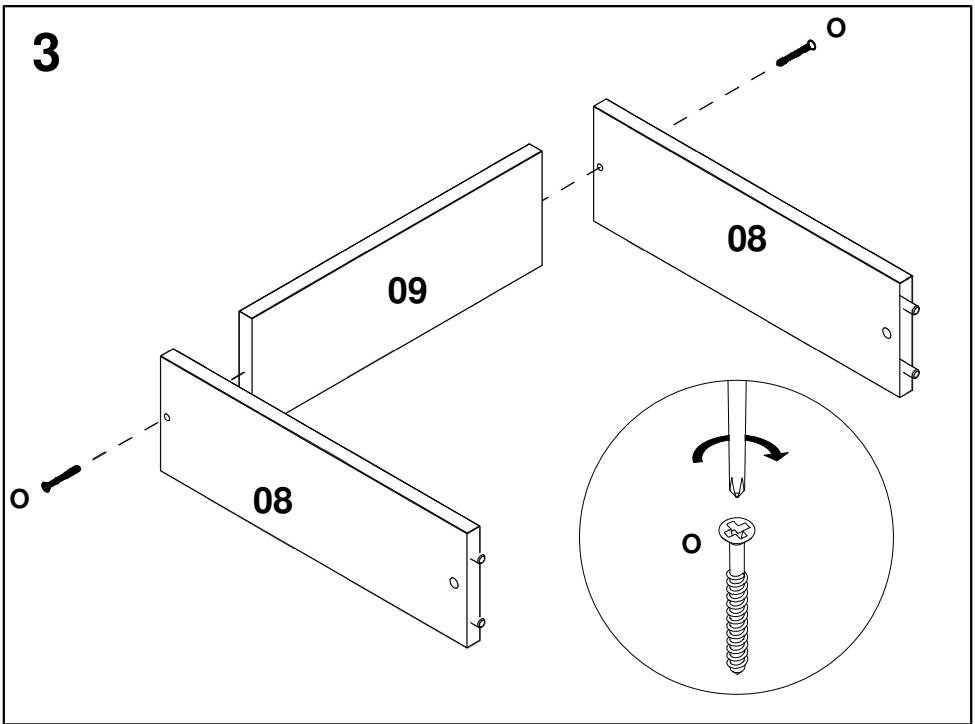

**5**

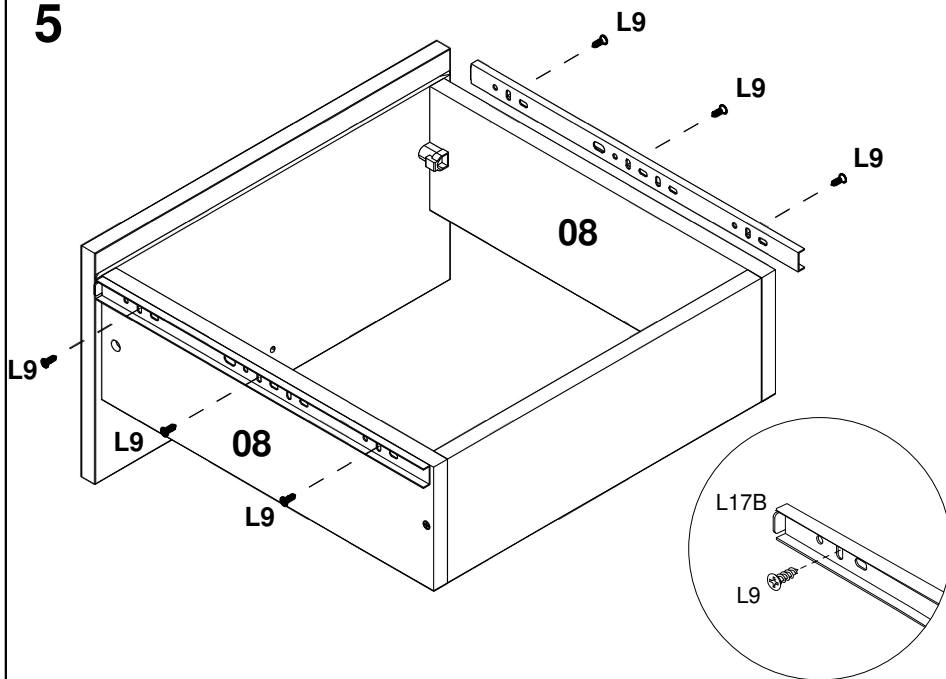

**6**

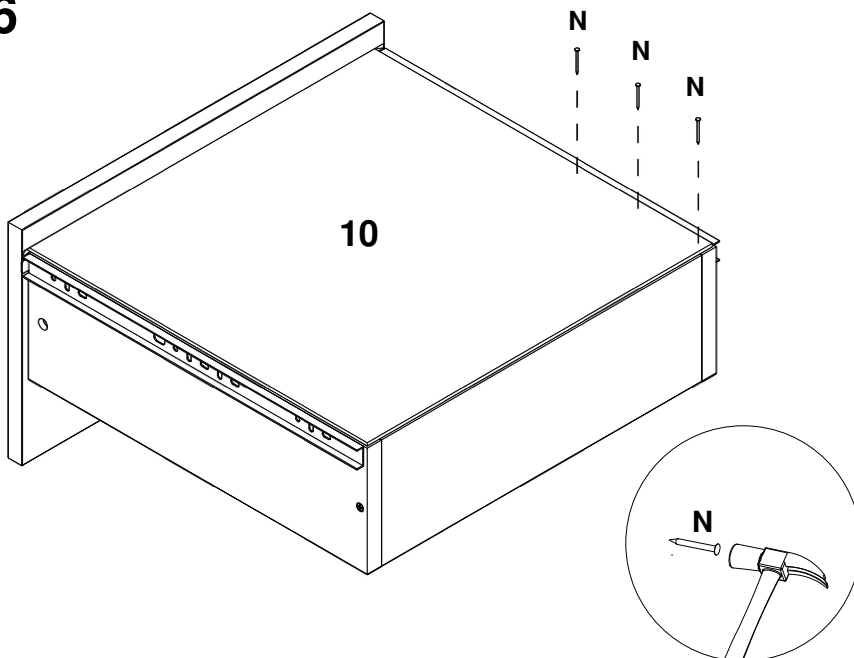

7

Inserção de gaveta

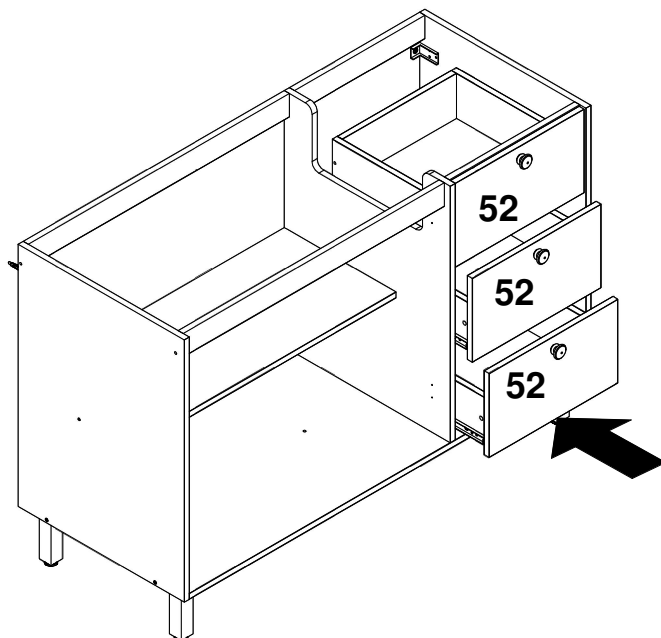

8

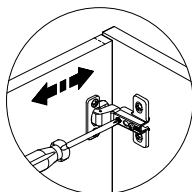

Regulagem Horizontal

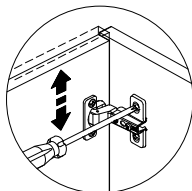
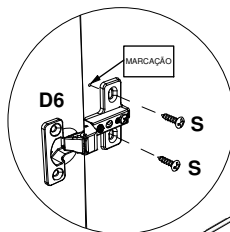

Regulagem Vertical

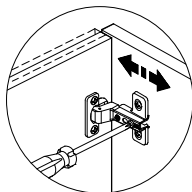

Regulagem Profundidade

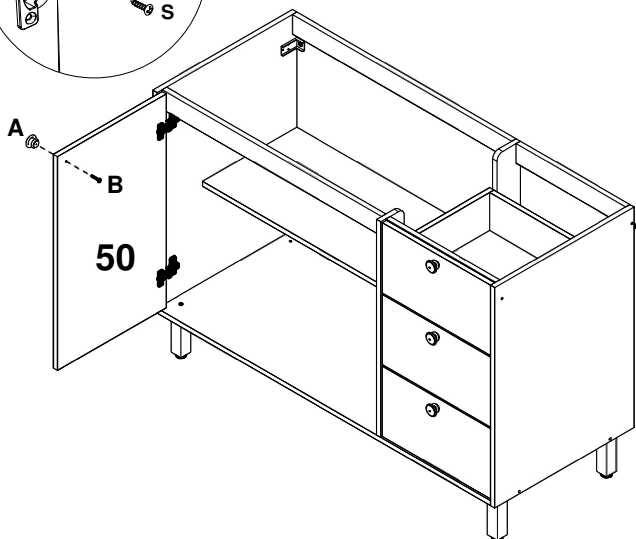

9

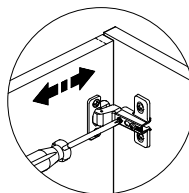
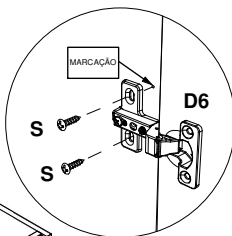
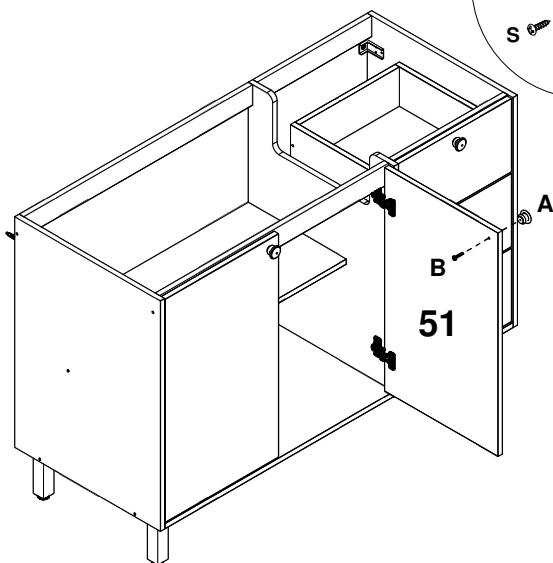

Regulagem Horizontal

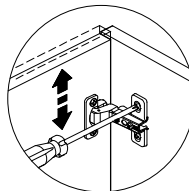

Regulagem Vertical

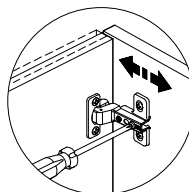

Regulagem Profundidade

10

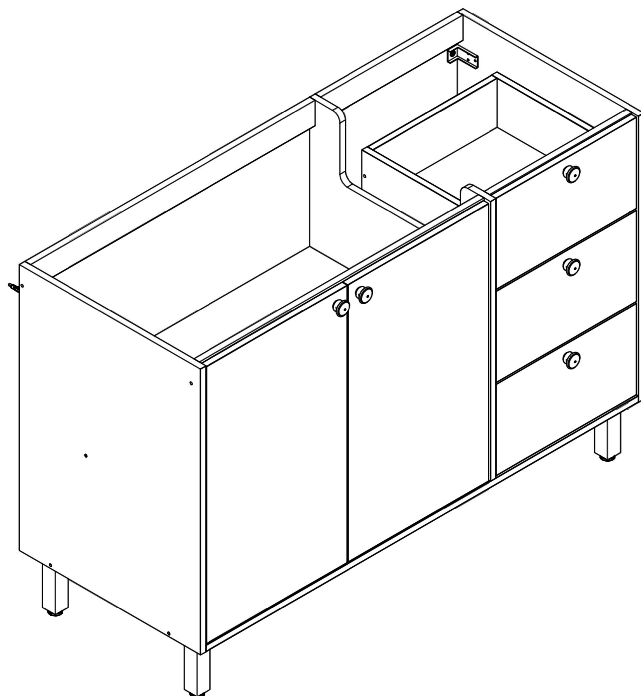

10

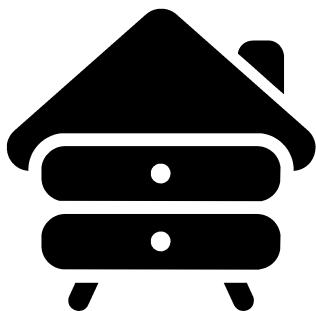
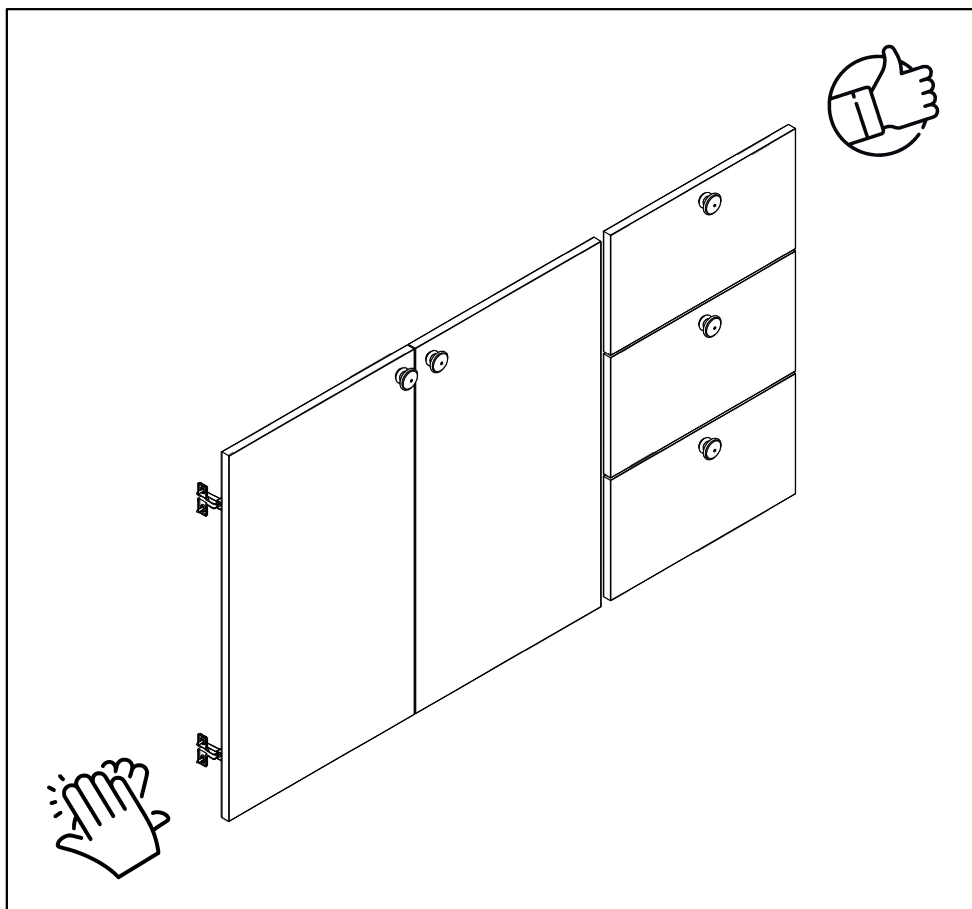

**yes casa**

V.00