

Observações / Observaciones

- Fixar as cavilhas utilizando cola /Fijar las clavijas utilizando pegamento;
- Siga a sequência numérica para realizar a montagem /Siga la secuencia numérica para realizar el montaje;
- Colocar todas as porcas cilíndricas antes de iniciar a montagem / Colocar todas las tuercas cilíndricas antes de iniciar el montaje;
- Fixar o forro e após colocar as prateleiras, gavetas, varões e calceiro / Fijar el fondo y después de colocar las estantes, cajones, varones y calceiro;

Altura Altura	Largura Anchura	Profundidade Profundidad
2000mm	1800mm	500mm

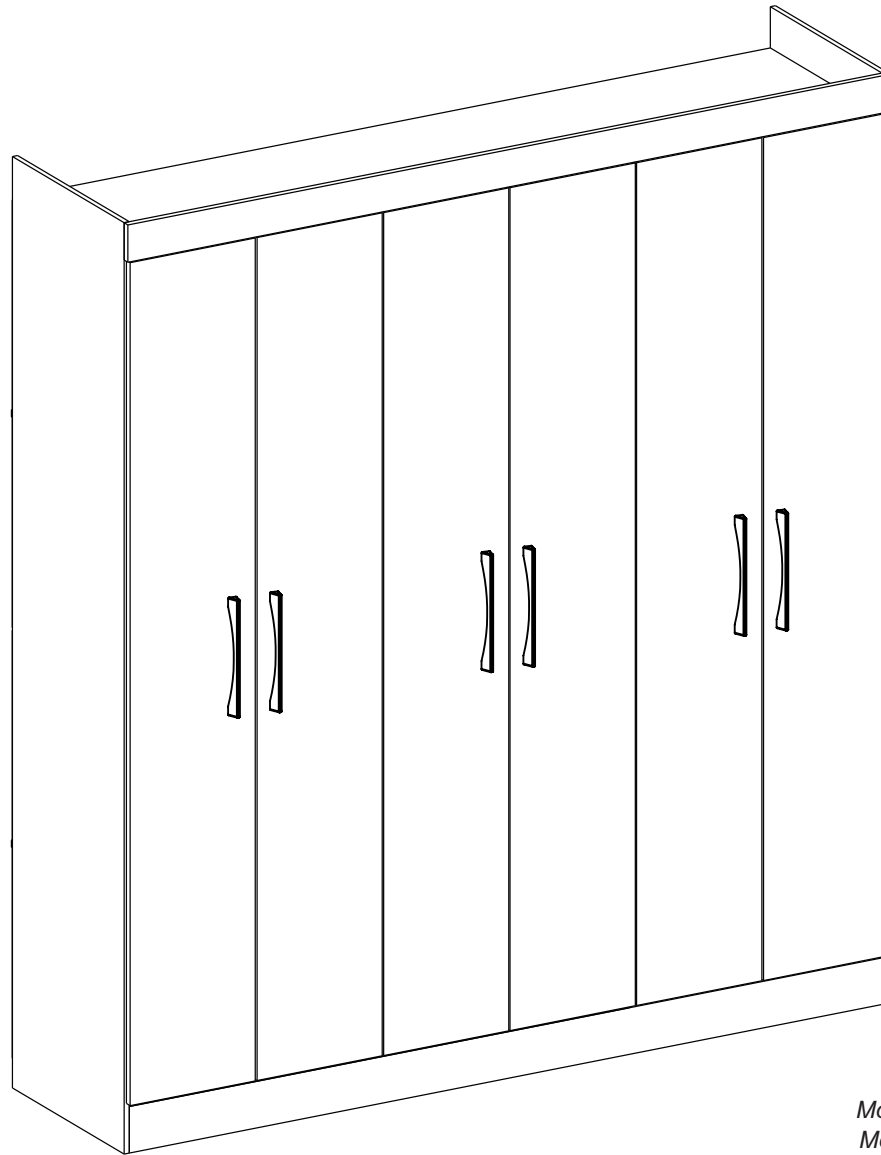

Requisitos para montagem
Requisitor para la montaje

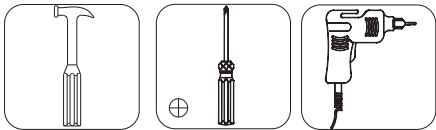

Imagens meramente ilustrativas
Imágenes meramente ilustrativas



Móvel Concluído
Móvil Concluído

ITEM ÍTEM	DESCRIÇÃO DESCRIPCIÓN	DESENHO DISEÑO	QUANTIDADE CANTIDAD
A	PORCA CILINDRICA TUERCA CILINDRICA 12X12		22
B	CAVILHA CLAVIJA 8X30		4
C	PARAFUSO FLANGEADO TORNILLO EMBRIDADO 4,5X45MM		12
D	SUPORE DE PRATELEIRA SOPORTE DE ESTANTE 8X10MM		16
E	SUPORE DE CABIDEIRO SOPORTE DE LA PERCHA		6
F	PARAFUSO CAB. CHATA TORNILLO CABEZA PESADA 3,5X12MM		88
G	PARAFUSO CAB. CHATA TORNILLO CABEZA PESADA 4,5X45 MM		10
H	DISTANCIADOR CILINDRICO ESPACIADOR CILINDRICO		8
I	KIT CORREDIÇA NEXT 350MM GUIA CORREDERA NEXT 350MM		2
J	PARAFUSO CAB. CHATA TORNILLO CABEZA PESADA 3,0X10 MM		20
K	PARAFUSO CAB. CHATA TORNILLO CABEZA PESADA 3,5X25MM		21
L	CAVILHA CLAVIJA 6X20		8
M	PARAFUSO CAB. CHATA TORNILLO CABEZA PESADA 3.5X40MM		1
N	CANTONEIRA ESQUINERO L 18X18		9
O	PREGO CLAVO 10X10		100
P	CALÇO PARA DOBRADIÇA CALZO PARA BISAGRA		18
Q	DOBRADIÇA BISAGRA		18
R	PORCA SEXTAVADA TUERCA SEXTAVADA		12
S	PARAFUSO ZINCADO TORNILLO ZINCADO		12
T	SUPORE DE CABIDEIRO SOPORTE DE LA PERCHA ' U '		1
U	PARAFUSO CAB. CHATA TORNILLO CABEZA PESADA 3.5X20MM		2
V	CAVILHA CLAVIJA 6X30		2
W	COLA BISNAGA PEGAMENTO BISNAGA		1
X	SAPATA ZAPATA L		8
Y	ETIQUETA MAXEL MÓVEIS LETRERO MAXEL MOVEIS		8
Z	PREGO CLAVO 12X12		1
AA	PARAFUSO CAB. CHATA TORNILLO CABEZA PESADA 3.5X30MM		10

60
50
40
30
20
10
0

ATENÇÃO: CONFERIR AS MEDIDAS DOS PARAFUSOS NA ESCALA ANTES DE UTILIZÁ-LOS
 ATENCIÓN: CONFIRAR LAS MEDIDAS DE LOS TORNILLOS EN LA ESCALA ANTES DE UTILIZARLOS

ITEM ÍTEM	DESCRIÇÃO DESCRIPCIÓN	DIMENSÕES DIMENSIONES	QUANTIDADE CANTIDAD
1	LATERAL EXTERNA ESQUERDA LATERAL EXTERNA IZQUIERDA	2000X451X12	1
2	RODAPÉ RODAPIÉ	1757X100X15	2
3	LATERAL EXTERNA DIREITA LATERAL EXTERNA DERECHA	2000X451X12	1
4	BASE INFERIOR TAPA INFERIOR	1757X451X12	1
5	LATERAL INTERNA	1799X451X12	1
6	LATERAL INT. LADO DE GAVETA LATERAL INT. LADO DEL CAJÓN	750X451X12	1
7	BASE SOBRE GAVETA TAPA SOBRE EL CAJÓN	577X451X12	1
8	BASE SUPERIOR TAPA SUPERIOR	1757X451X12	1
9	BATENTE TOPE	1047X70X12	1
10	VISTA FRONTAL VISTA DE FRENTE	1780X80X15	1
11	TACO FIXA VISTA TACO FIJA VISTA	100X40X15	3
12	FRENTE DE GAVETA FRENTE DEL CAJÓN	530X145X15	2
13	LATERAL DE GAVETA LADO DEL CAJÓN	350X100X12	4
14	FORRO DE GAVETA FONDO DEL CAJÓN	475X357X2.8	2
15	PARTE ATRAS DE GAVETA RIPA DE TRÁS DEL CAJÓN	465X70X12	2
16	PRATELEIRA ESTANTE	577X338X12	4
17	CALCEIRO	570X400	1
18	VARÃO DE MADEIRA VARÓN DE MADERA	1160X22	1
19	FORRO FONDO	1775X457X2.8	4
20	PERFIL PROFILE	1780MM	3
21	PORTA PUERTA	1810X292X15	6
22	PUXADOR TIRADOR	192MM	6

PASSO 1 PASO 1

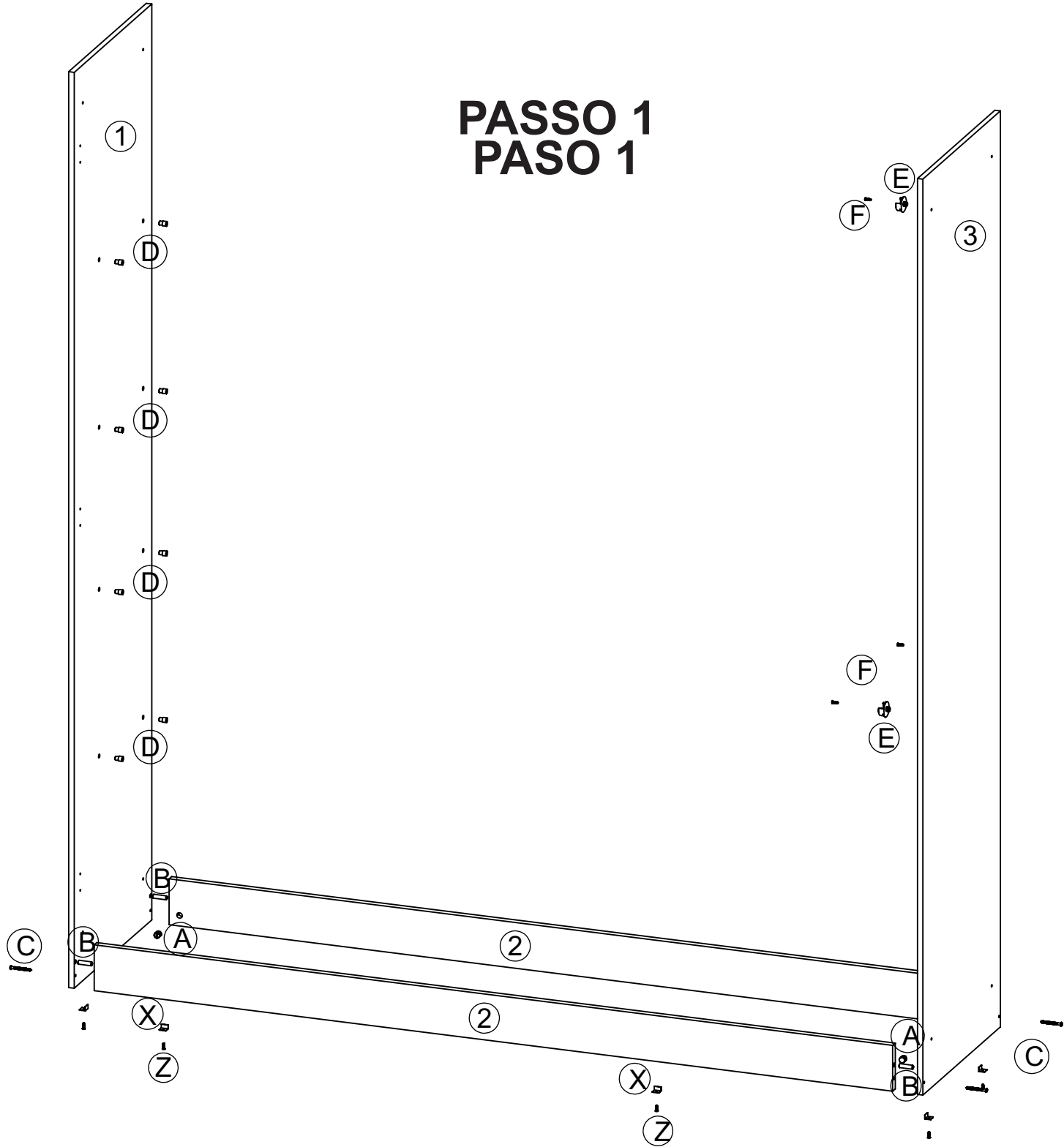

PASSO 2 PASO 2

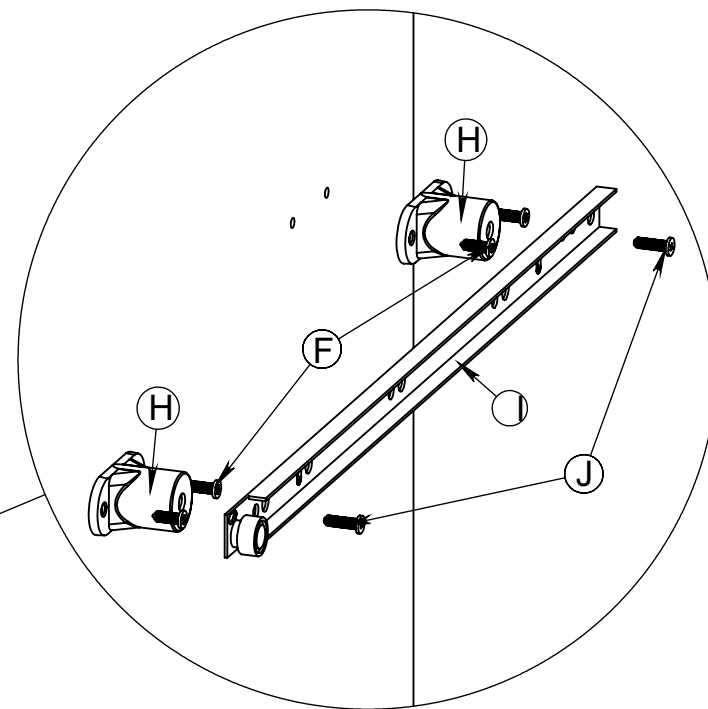
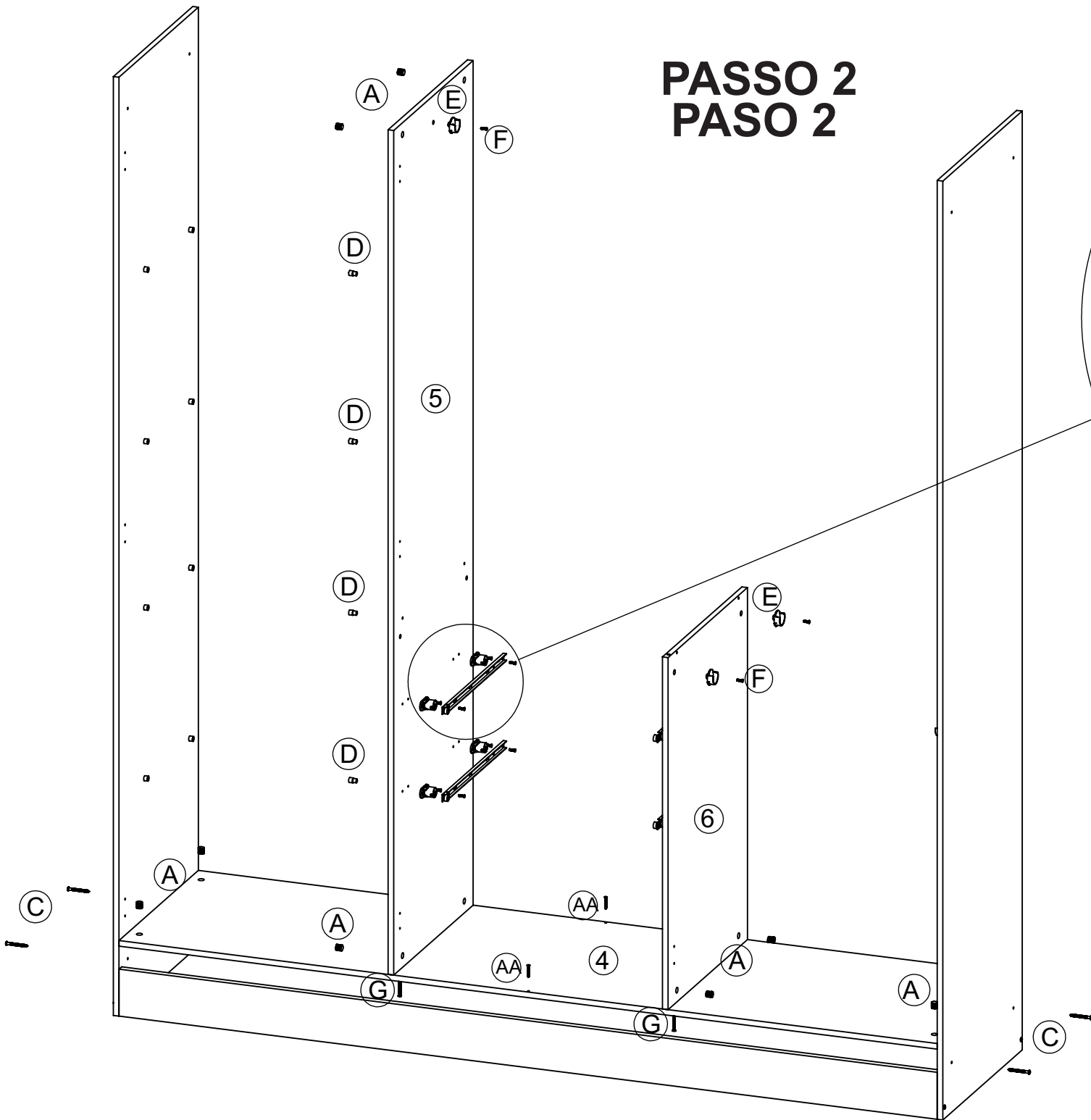

DETALHE A
DETALHE A

PASSO 3 PASO 3

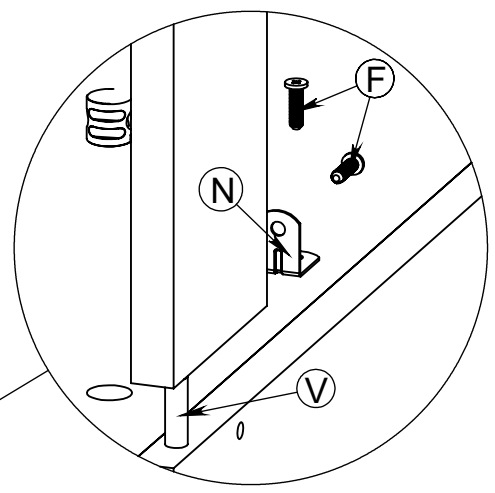
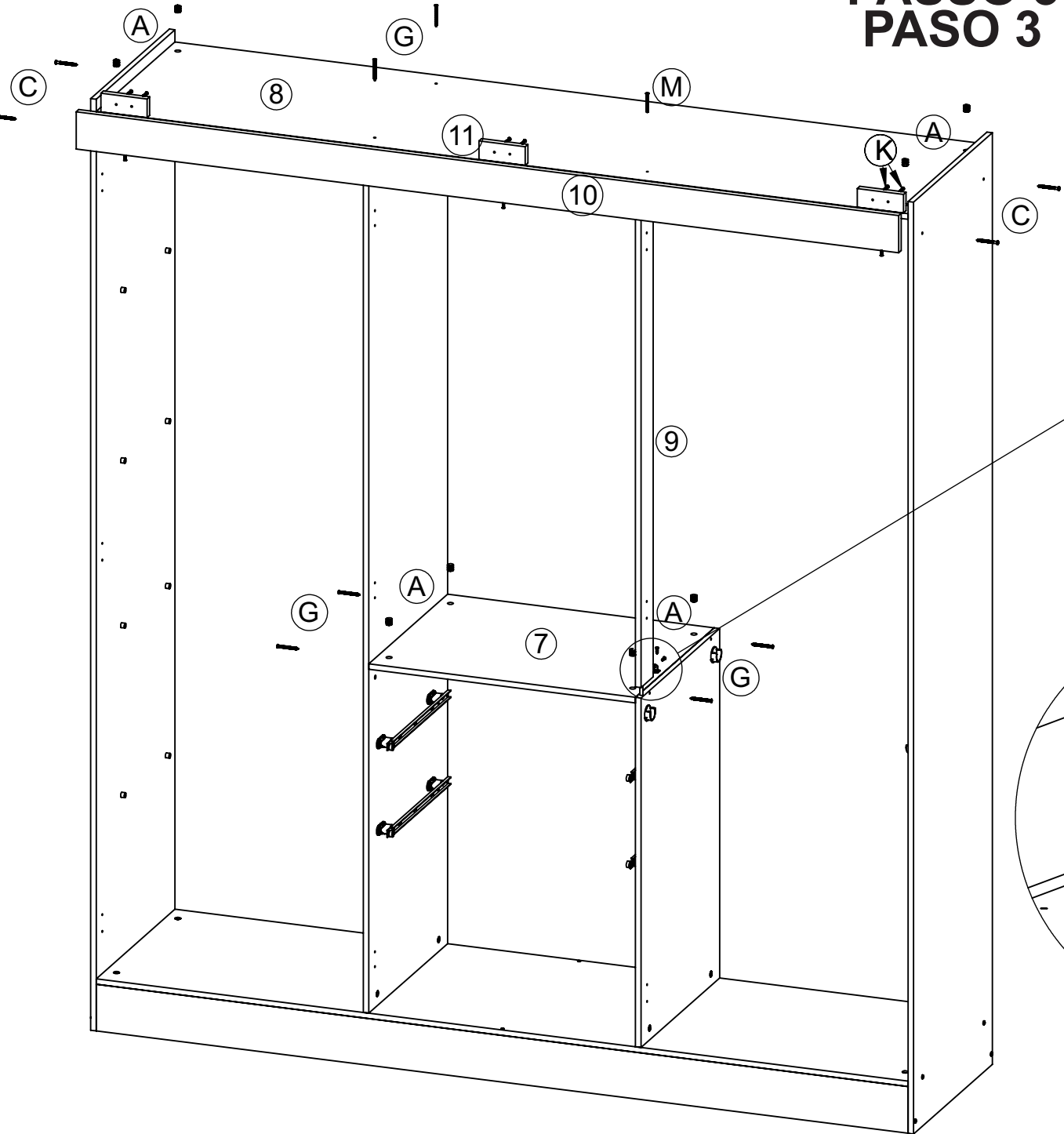

DETALHE B
DETALLE B

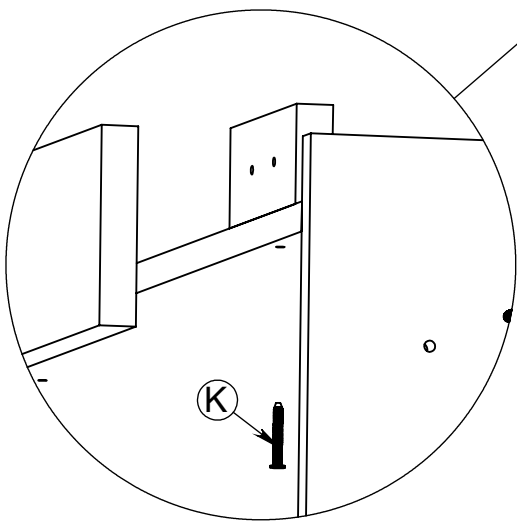

DETALHE C
DETALLE C

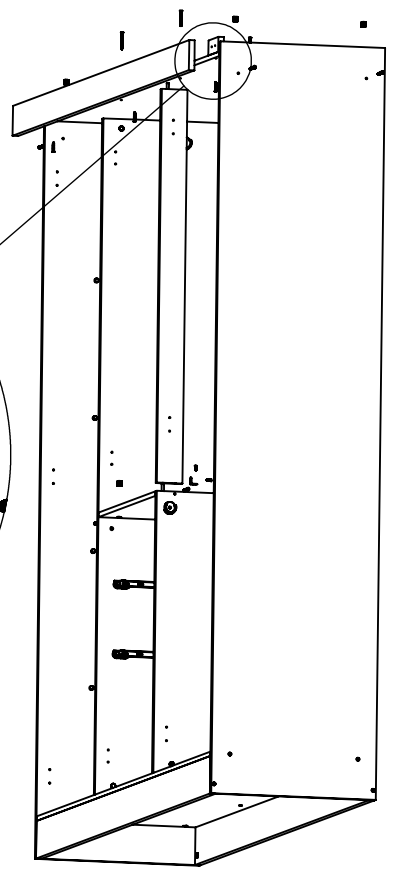

PASSO 4 PASO 4

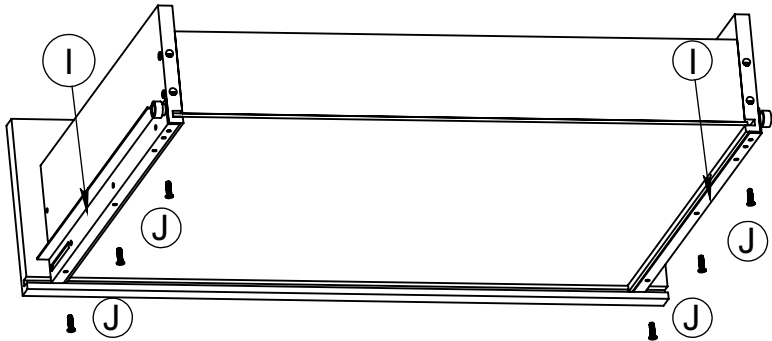
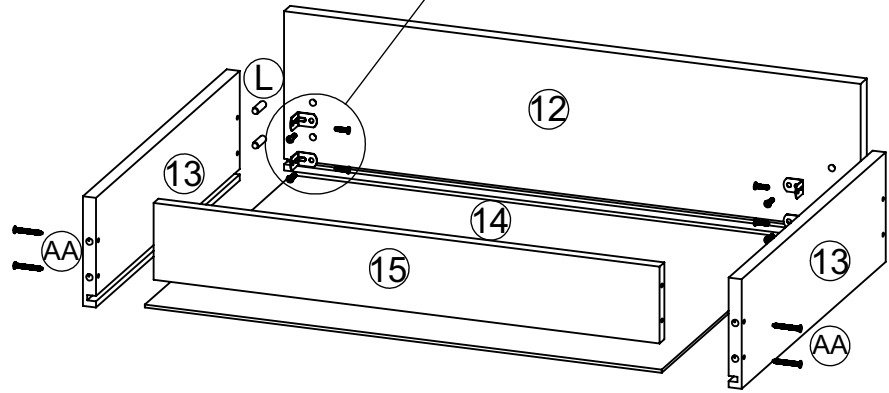
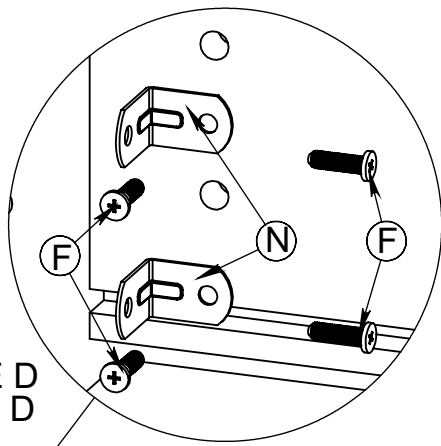

PASSO 5 PASO 5

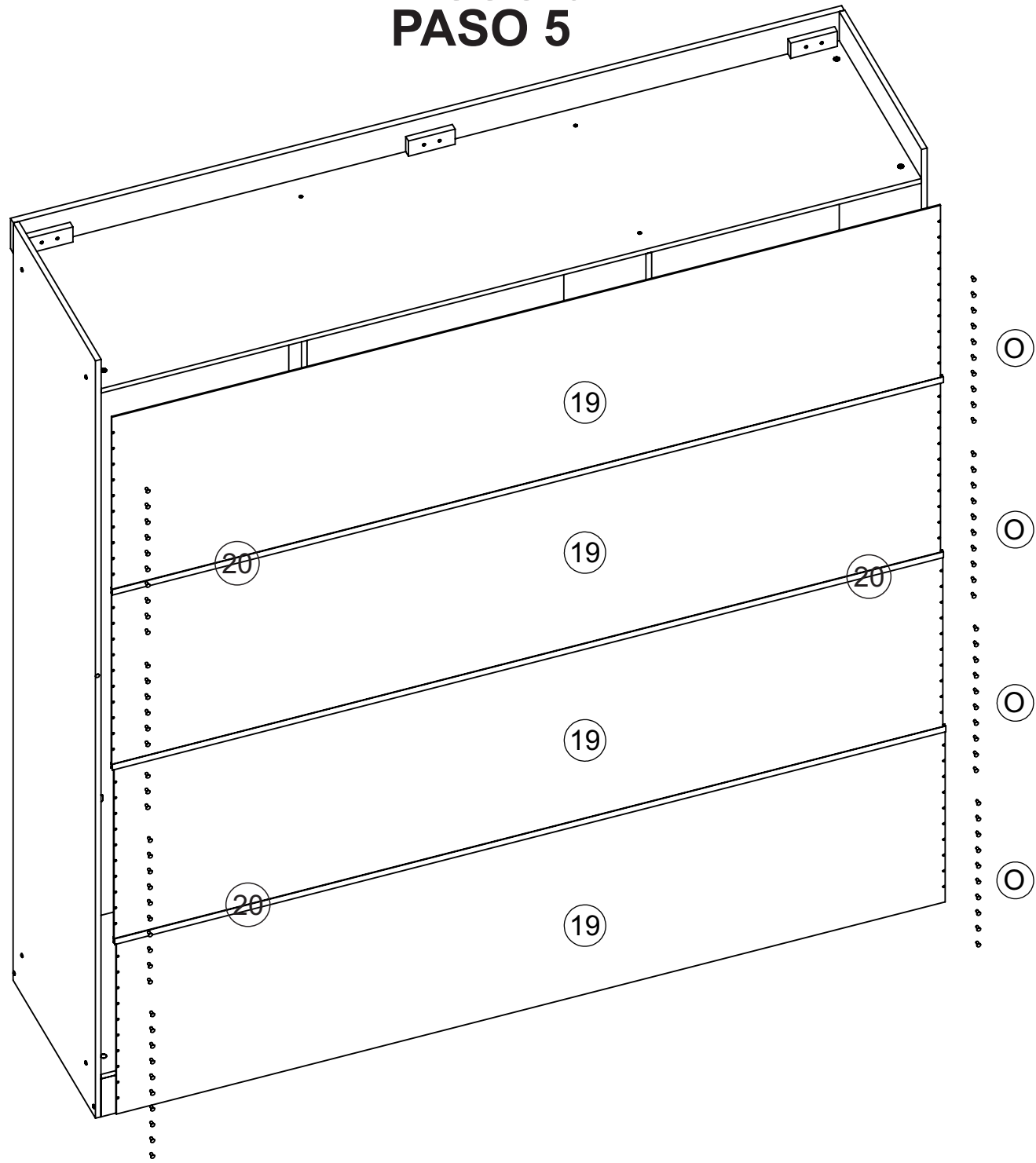

PASSO 6 PASO 6

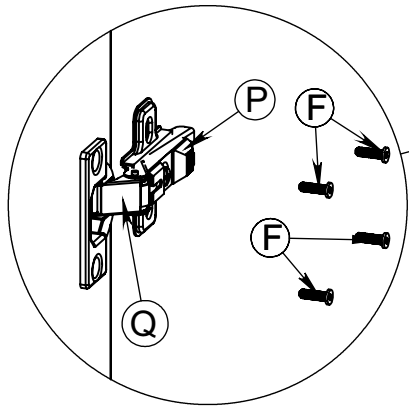

DETALHE E
DETALLE E

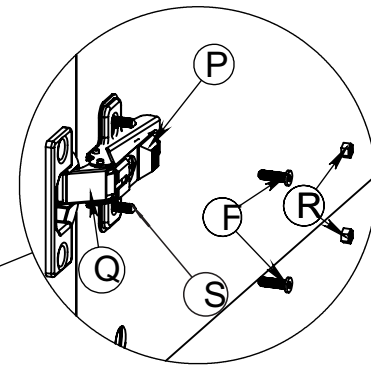
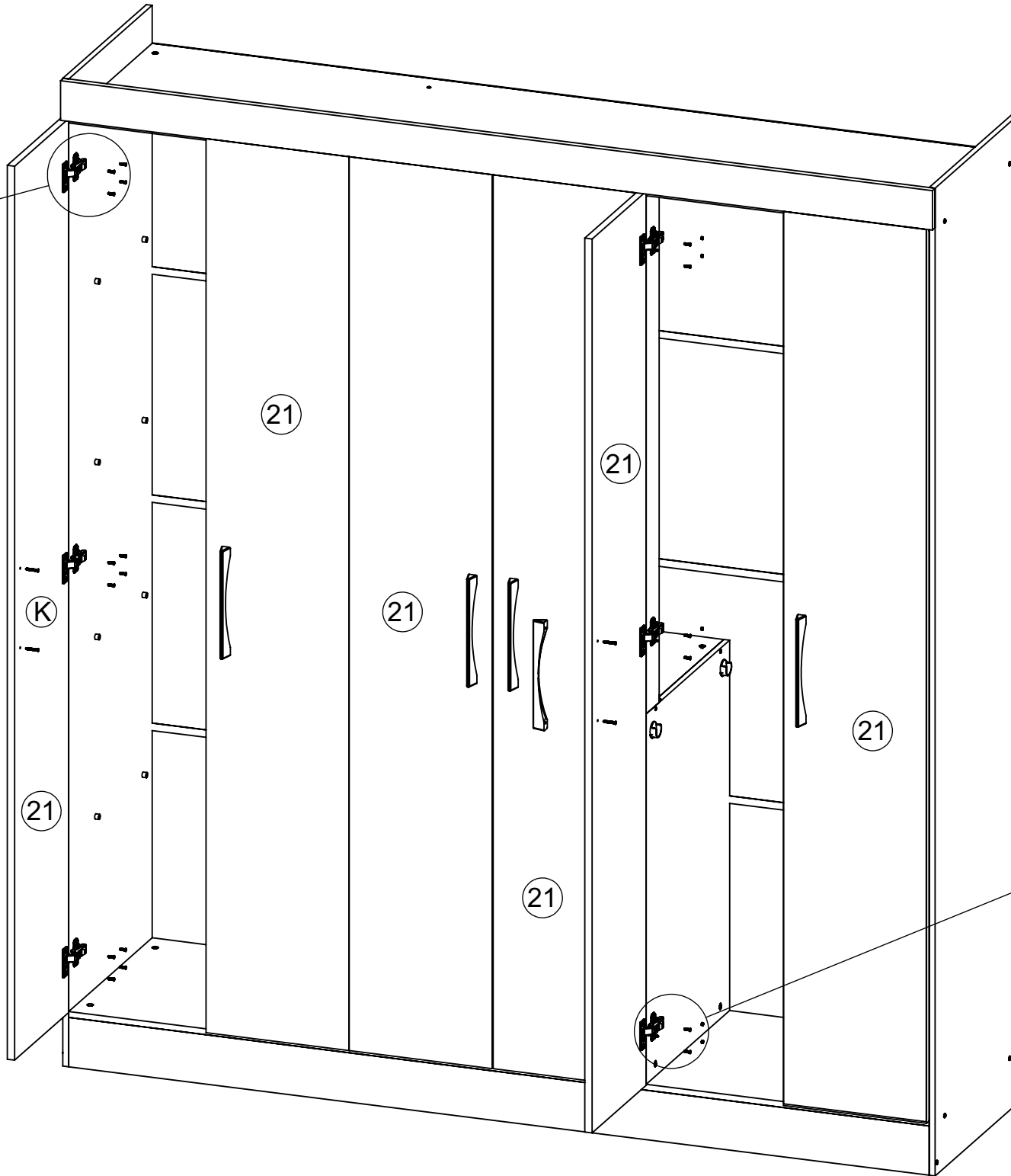

DETALHE F
DETALLE F