

RACK CAVA 1550

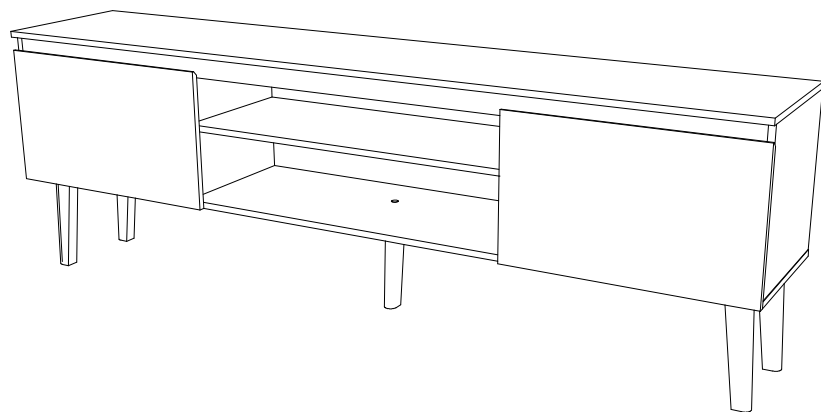

ESCANEI-ME
PARA ACESSO AO
VÍDEO DE MONTAGEM



Utilizar a régua abaixo para medir os componentes.



medidas em mm

Composição do Produto

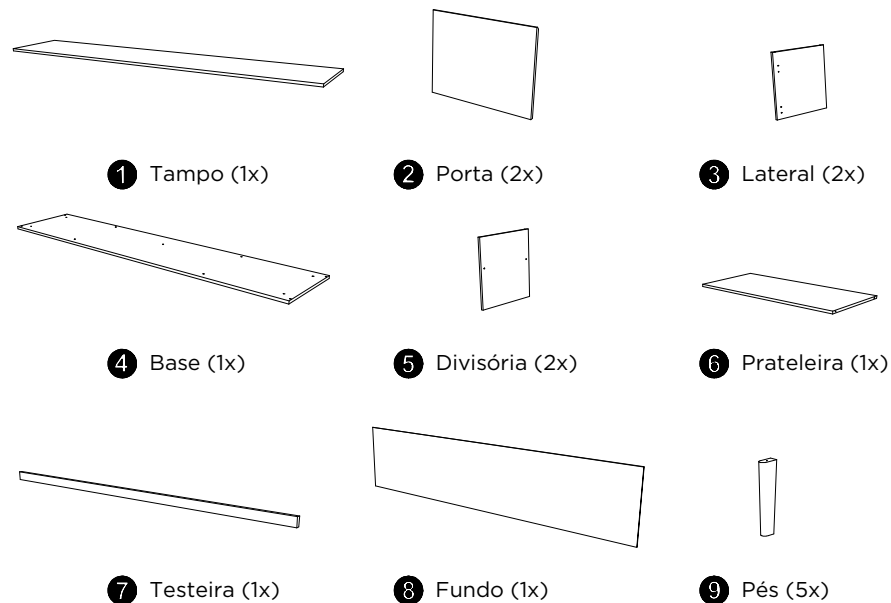

Componentes de Montagem



A- Parafuso phillips
chipboard 3x30 (8x)



B- Cavilha 6x30 (20x)



C- Cantoneira 2
furos (12x)



D- Tapa furo adesivo
branco (5x)



E- Prego 10x10 (20x)



F- Dobradiça (4x)

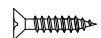

G- Parafuso phillips
chipboard 4x12 (40x)



H- Parafuso phillips
chipboard 6x60 (5x)



Pessoas necessárias
para montar o produto



Tempo de montagem
aproximado



Grau de
dificuldade



Não utilizar químicos
ou abrasivos na
limpeza, evitar batidas
e contato com
objetos cortantes



Pano umedecido
com água seguido
de pano seco



Capacidade máxima
suportável, distribuída
uniformemente

Atenção

- 1- Leia atentamente toda a instrução antes de iniciar a montagem.
- 2- A montagem do produto deverá ser feita em uma superfície limpa e plana. Aconselhamos utilizar a própria embalagem para forrar o chão a fim de não danificar o produto.
- 3- Reservar área livre para montagem do produto.

1 Montagem

Ferramenta necessária para montagem

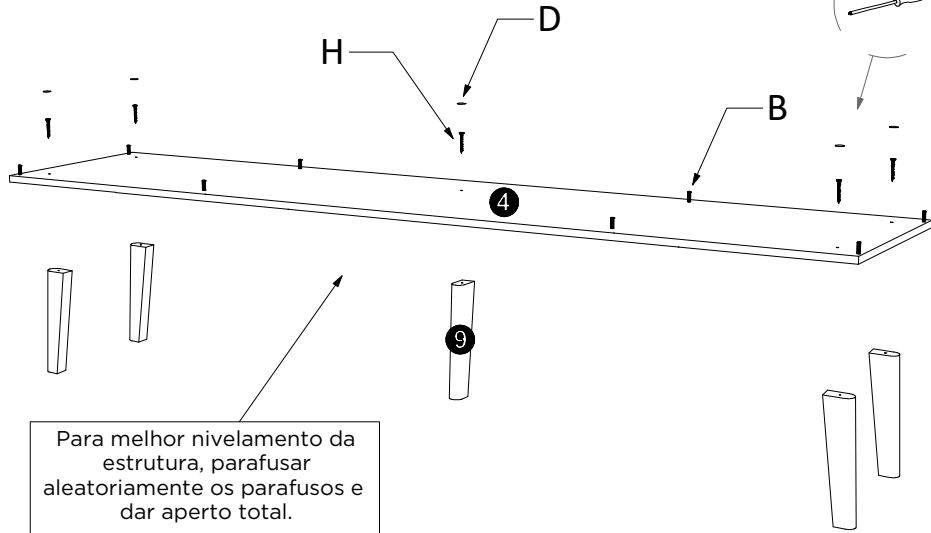
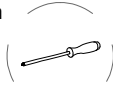

2

