

Capacidade de Carga - Load Capacity - Capacidad de carga

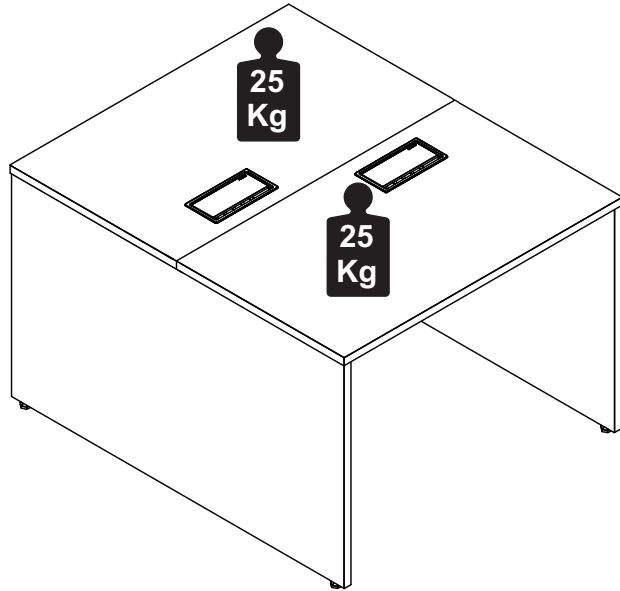

Manutenção e Limpeza

Vidros: pano levemente umedecido com álcool, seguido de pano seco.
Madeiras: pano levemente umedecido com água, seguido de pano seco.
*Nunca utilizar produtos químicos ou abrasivos.

Maintenance and Cleaning

Glasses: cloth lightly moistened with alcohol, followed by dry cloth.
Woods: cloth slightly moistened with water, followed by cloth seco.
*Never use chemicals or abrasives.

Mantenimiento y Limpieza

Vidrios: legeramente humedecido con alcohol, seguido de un paño seco.
Madera: ligeramente humedecido con agua, seguido de un paño seco.
*No utilice nunca productos quimicos o abrasivos.

INSTRUÇÕES DE MONTAGEM ASSEMBLY INSTRUCTIONS INSTRUCCIONES DE MONTAJE

PLATAFORMA INICIAL DUPLA PAINEL SMART DOUBLE SMART PANEL HOME PLATFORM PLATAFORMA HOGAR DOBLE PANEL DE LUZ

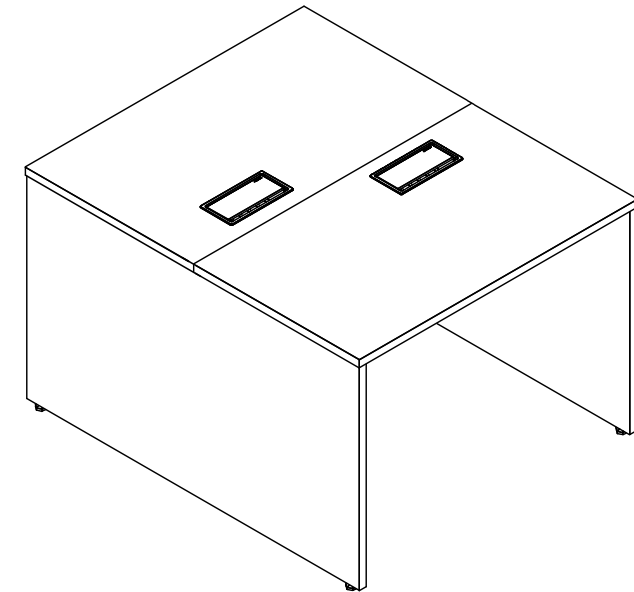

1 P.



8mm



35min

REF. #LEP1156-1356-1556-1756-1157-1357-1557-1757



MOBILIÁRIO
PARA ESCRITÓRIO

GEBB Work Ind. de Móveis Ltda.
Rua Felix Roman, 190
São Valentin

95709-170 - Bento Gonçalves - RS - Brasil
Fone: (0XX54) 3454-1105 - (0XX54) 3453-1407
Phone: (0XX54) 3454-1105 - (0XX54) 3453-
1407 E-mail: pedidos@gebbwork.com.br
www.gebbwork.com.br
WhatsApp: +55 54 99177-8324

LISTA DE PEÇAS

- 01 - Pé Lateral Esq. / Dir.
- 02 - Tampo
- 03 - Painel Frontal
- 04 - Travessa Inferior

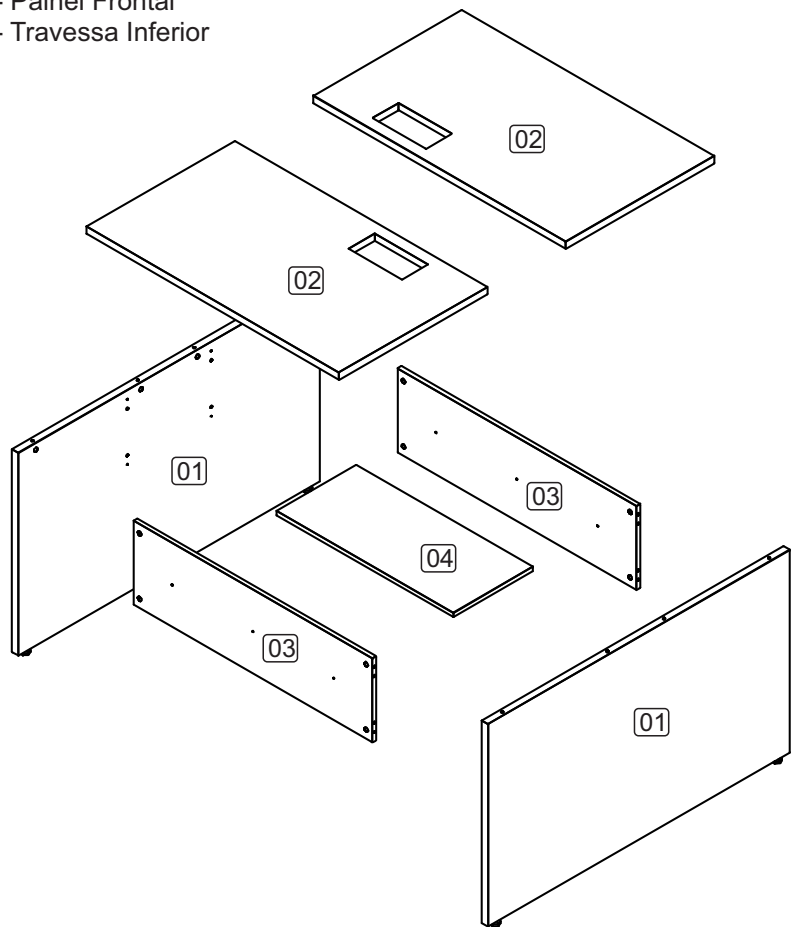

LISTA DE PIEZAS

- 01 - Pie Lateral Derecho / Izquierdo
- 02 - Tapa
- 03 - Panel frontal
- 04 - Callejón Inferior

PARTS IDENTIFICATION

- 01 - Right / Left Side
- 02 - Top
- 03 - Front Panel
- 04 - Lower Alley

4

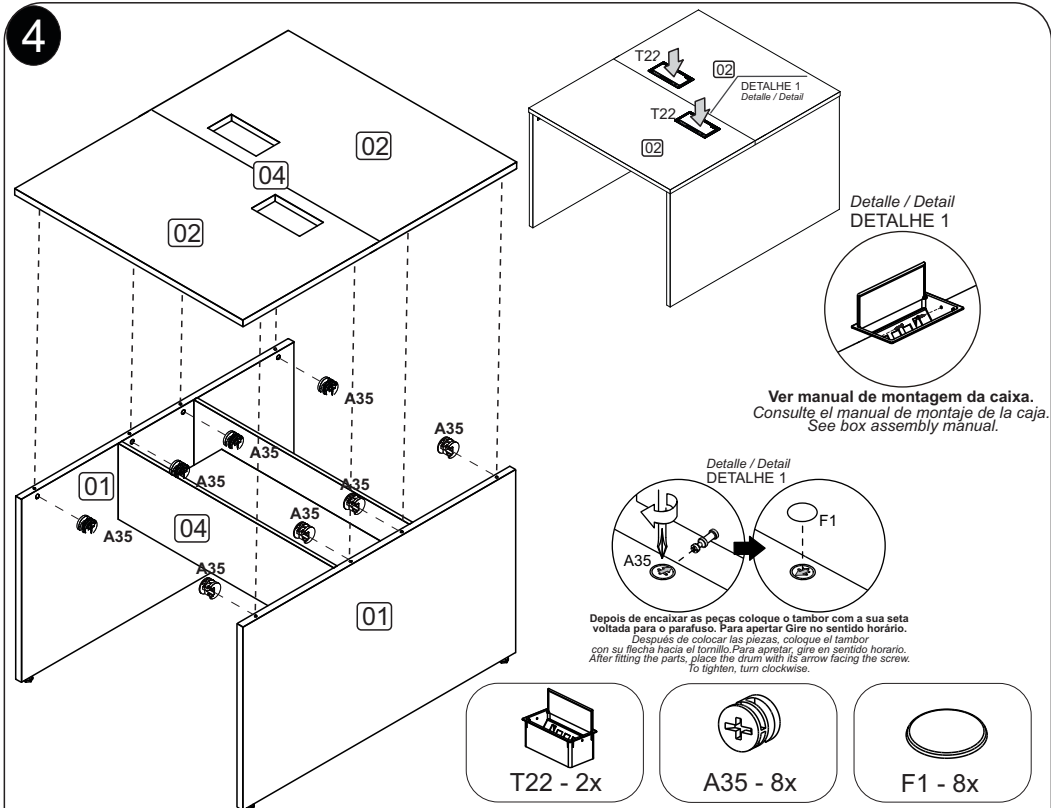

5

POSICIONE AS CHAPAS DE UNIÃO SOBRE AS MARCAÇÕES

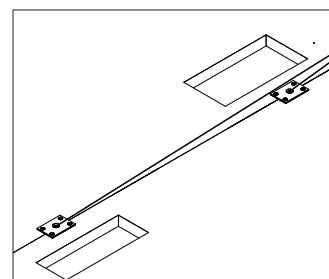
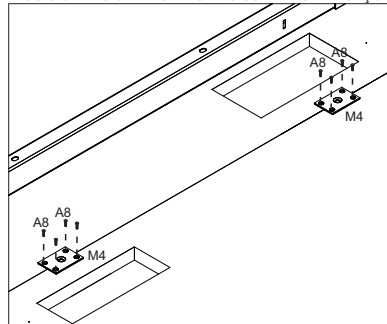

UTILIZE A FURAÇÃO CENTRAL COMO GABARITO
REPASSE A FURAÇÃO COM BROCA Ø8mm

PARA INSTALAÇÃO DE PAINÉIS DIVISORES COM USO DE PITÕES UTILIZE O MANUAL DE MONTAGEM EXCLUSIVO EXCLUSIVO DE CADA TIPO DE PITÃO

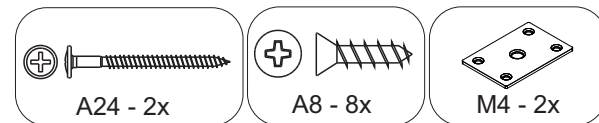

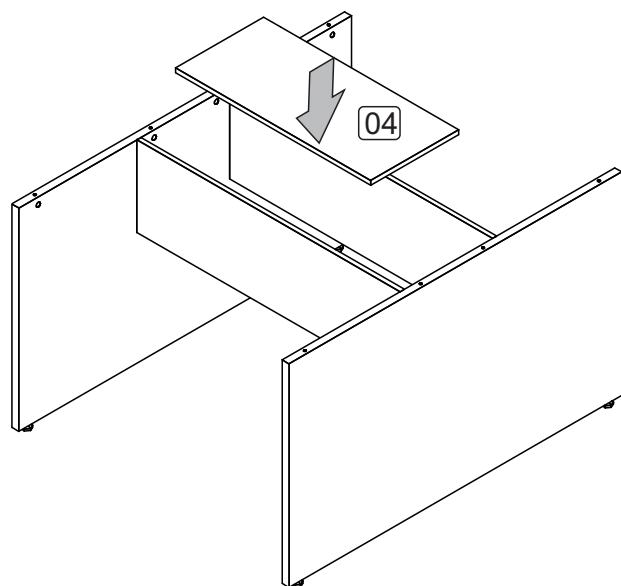

ACESSÓRIOS ACCESSORIES ACCESORIOS

A10 - PARAF. 4,0x20 CF
6x



A24 - PARAF. 5,0x60 CF
2x



(Para fixação dos painéis
divisores sem pitão)

A36 - BUCHA M6x13
8x



L8 - SAPATA PLÁSTICA
SEXTAVADA 5/16X7/8 **4x**



A29 - PARAF. MINIFIX
M6x33m **8x**

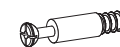

L5 - BUCHA PLÁSTICA
P/SAPATA 5/16 **4x**



A35 - TAMBOR MINIFIX
16x



B1 - SUPORTE PRAT.
METÁLICO **6x**



A32 - PARAF. MINIFIX
8x

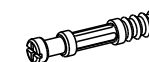

D1 - CAVILHA 8x30
8x

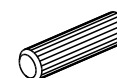

F1 - TAPA FURO Ø18
8x



T22 - CAIXA DE TOMADA
2x

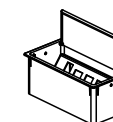

M4 - CHAPA P/CONEXÃO
05 FUROS **2x**

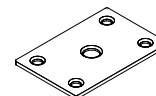

A9 - PARAF. 4,0x16 CC
8x



1 PRÉ-MONTAGEM

Preasamblea
Pre-assembly

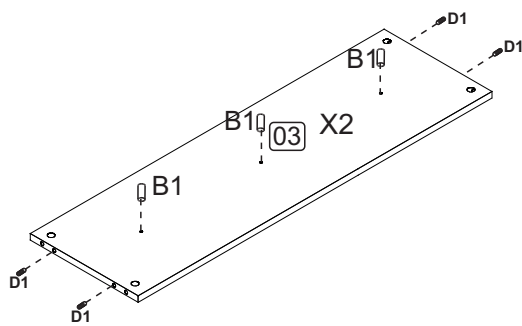
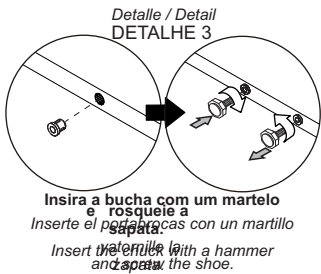
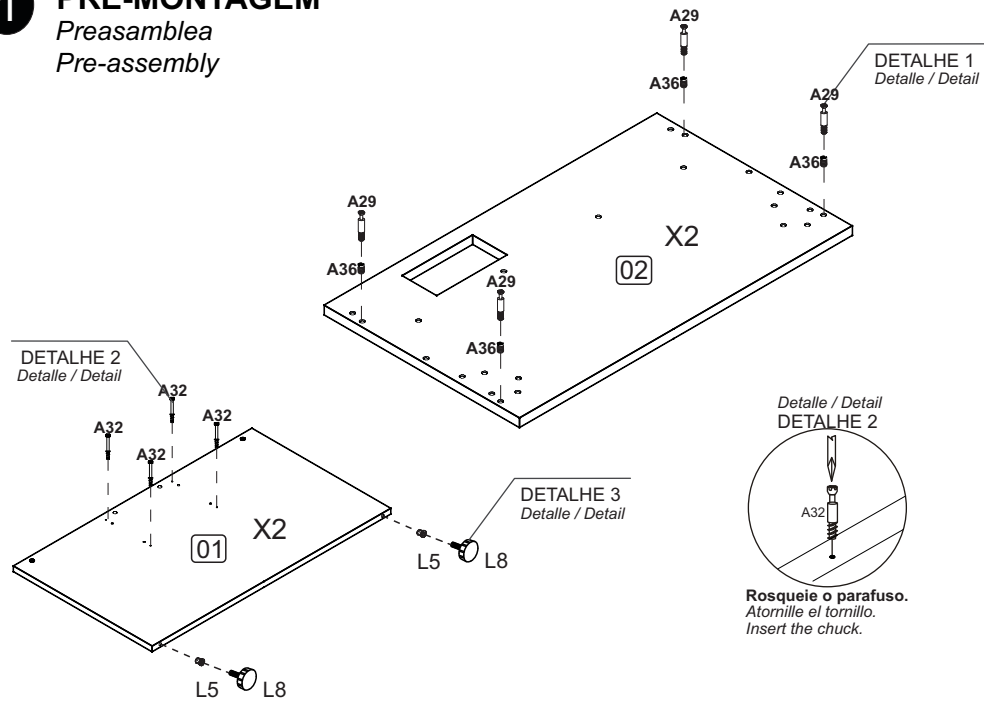

04/08

2 MONTAGEM

Armado
Assembly



Depois de encaixar as peças coloque o tambor com a sua seta voltada para o parafuso. Para apertar Gire no sentido horário.
Después de colocar las piezas, coloque el tambor con su flecha hacia el tornillo. Para apretar, gire en sentido horario.
After fitting the parts, place the drum with its arrow facing the screw.
To tighten, turn clockwise.

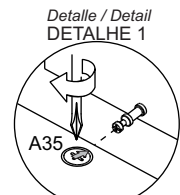
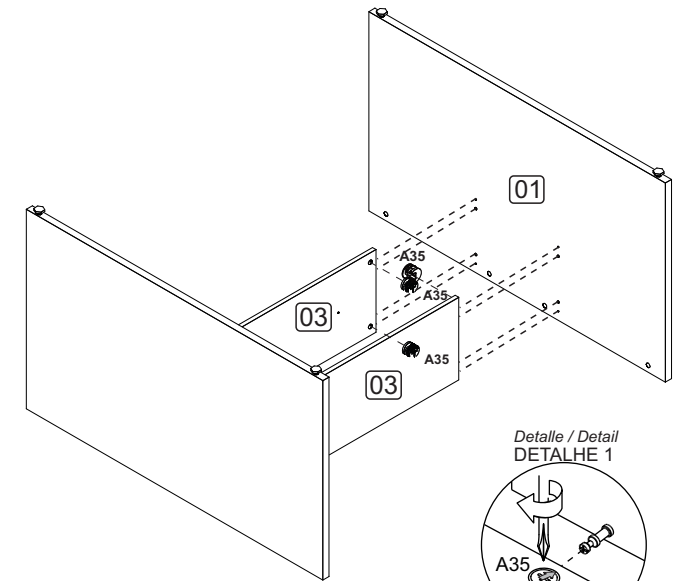
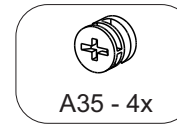
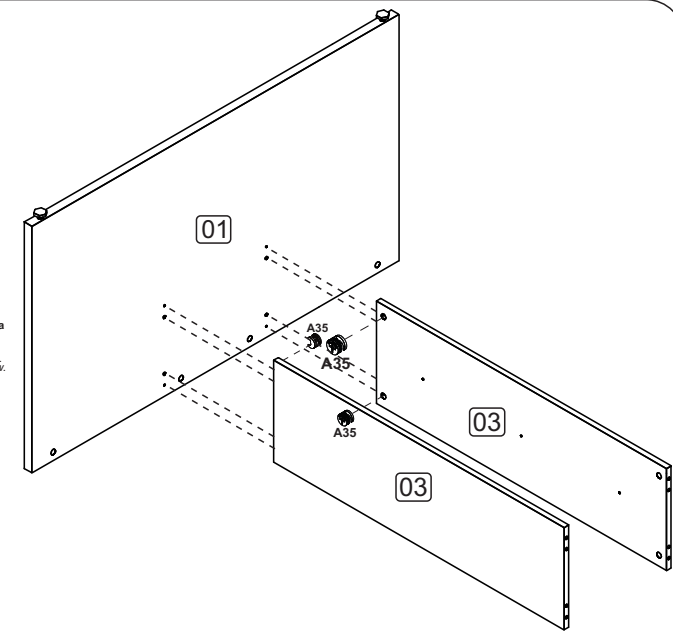

Depois de encaixar as peças coloque o tambor com a sua seta voltada para o parafuso. Para apertar Gire no sentido horário.
Después de colocar las piezas, coloque el tambor con su flecha hacia el tornillo. Para apretar, gire en sentido horario.
After fitting the parts, place the drum with its arrow facing the screw.
To tighten, turn clockwise.



05/08