

Item	Caixa Caja Box	Qtd Ctd Qty	Descrição Descripción Description	Medidas (mm) Dimensions (mm) Size (measurements) (mm)
01	2/6	01	Base Base Base	2515x575x15
02	2/6	02	Travessa lateral base Carril lateral base Base side crossbar	537x90x15
03	2/6	03	Travessa central base Carril central base Central base rail	537x70x15
04	3/6	01	Travessa frontal base Carril delantera de la base Base front crossbar	2566x70x25
05	1/6	01	Lateral esquerda Lateral izquierda Left side	2285x575x15
06	4/6	01	Divisão esquerda División de la izquierda Left Division	1841x575x15
07=15	5/6	01	Tampo das Gavetas Tapa de los cajones Drawer Top	828x450x15
08	2/6	01	Divisão Central División Central Central Division	1476x455x15
09	4/6	02	Prateleira menor Pequeño estante Small shelf	450x407x15
10	2/6	01	Prateleira Estante Shelf	829x460x15
11	2/6	01	Chão do Maleiro Piso del Armario de Equipaje Floor of the Maleiro	2515x575x15
12	2/6 e 3/6	02	Ripa do Maleiro Listón del Armario de Equipaje Clapboard luggage locker	414x73x15
13	4/6	01	Divisão direita División derecha Right division	1841x575x15
14	1/6	01	Lateral direita Lateral derecha Right side	2285x575x15
15=07	5/6	01	Tampo das Gavetas Tapa de los cajones Drawer Top	828x450x15
16	3/6	01	Tampo Tapa Top	2565x595x15
17	3/6	01	Fundo Superior Fondo Superior Superior background	2539x436x3
18	3/6	06	Fundo Fondo Bottom	1863x421x3
19	3/6	01	Moldura Frontal Superior Marco frontal superior Upper Front Frame	2605x80x25
20	3/6 e 5/6	02	Moldura Lateral Marco lateral Lateral Frame	535x80x25
21	3/6	04	Ripa lateral Ripa lateral Ripa side	502x80x25
22	1/6 e 6/6	06	Porta Puerta Door	2273x417x15
23	5/6	06	Frente de gaveta Frente de cajón Front of drawer	770x145x15
24	4/6	12	Lado de gaveta Lado del cajón Side of drawer	400x122x15
25	1/6	06	Fundo de gaveta recortado Fondo del cajón recortado Clipped drawer bottom	734x411x3
26	5/6	06	Ripa de trás Malla detrás Rear lath	753x122x15



Ind. e Com. de Móveis Henn
Mondai - SC - Brasil
☎ +55 49 3674.3500
@moveishenn
www.henn.com.br

INSTRUÇÕES DE MONTAGEM

INSTRUCCIONES DE MONTAJE
ASSEMBLY INSTRUCTIONS

Roupeiro Elenco 06 Portas | Armario Elenco 06 Puertas | Wardrobe Elenco 06 doors

- c D227-101 Café
- c D227-108 Duna/Off White

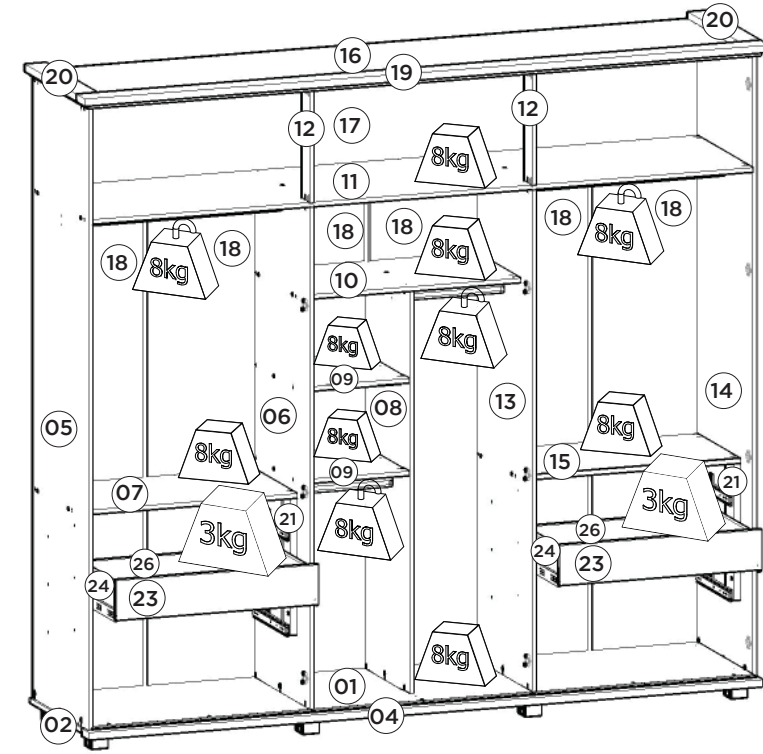
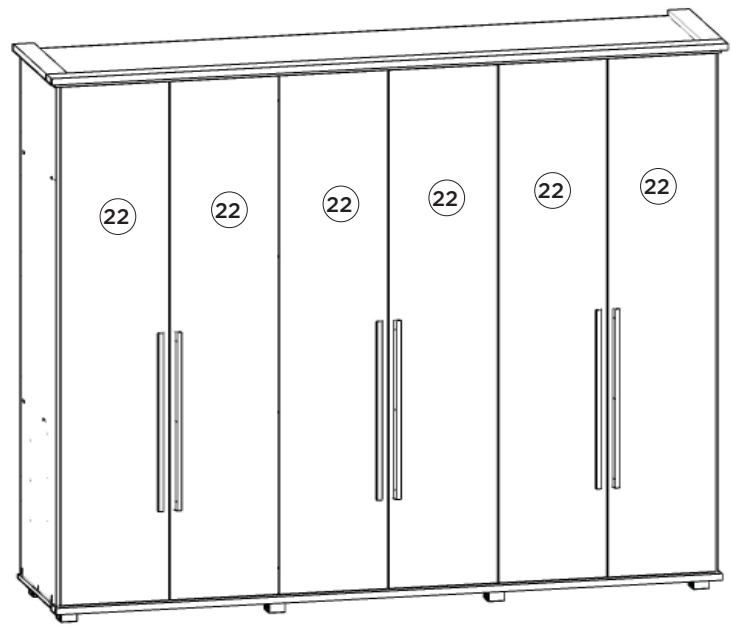

Pesos máximos recomendados com carga distribuída
Peso máximo recomendado con la carga distribuida
Recommended maximum weights with evenly distributed.

Ferragens | Herrajes | Hardware

A 21x Parafuso 4,0x35mm CHT. Tornillo 4,0x35mm CHT. Screw 4,0x35mm CHT.	B 22x Parafuso 4,0x30mm FLA. Tornillo 4,0x30mm FLA. Screw 4,0x30mm FLA.	C 17x Parafuso 4,0x25mm CHT. Tornillo 4,0x25mm CHT. Screw 4,0x25mm CHT.	D 16x Parafuso 4,0x25mm FLA. Tornillo 4,0x25mm FLA. Screw 4,0x25mm FLA.	E 31x Parafuso 3,5x40mm CHT. Tornillo 3,5x40mm CHT. Screw 3,5x40mm CHT.	F 18x Parafuso 3,5x25mm FLA. Tornillo 3,5x25mm FLA. Screw 3,5x25mm FLA.
G 76x Parafuso 3,5x14mm FLA. Tornillo 3,5x14mm FLA. Screw 3,5x14mm FLA.	H 100x Parafuso 3,5x12mm CHT. Tornillo 3,5x12mm CHT. Screw 3,5x12mm CHT.	I 12x Parafuso 3,0x30mm CHT. Tornillo 3,0x30mm CHT. Screw 3,0x30mm CHT.	J 12x Parafuso 3,0x16mm CHT. Tornillo 3,0x16mm CHT. Screw 3,0x16mm CHT.	K 104x Cavilha 8x25mm Cinta 8x25mm Dowel 8x25mm	L 194x Prego 10x10mm Clavo 10x10mm Nail 10x10mm
M 68x Fixador de fundos Fijador de fondos Bottom fixer	N 07x Parafuso minifix Tornillo minifix Minifix bolt	O 07x Tambor minifix Tambor minifix Minifix drum	P 16x Porca Sextavada Tuerca Hexagonal Hexagon Nut	Q 12x Cantoneira plástica Cantoneira plástica Plastic angle brackets	R 12x Cantoneira suporte triangular Cantoneira soporte triangular Triangle support angle
S 09x Sapata retangular 70x60mm Zapata rectangular 70x60mm Rectangular shoe 70x60mm	T 12x Distanciador de corrediça Distanciador de deslizamiento Sliding spacer	U 08x Suporte cabideiro Soporte de percha Coat hanger support	V 02x Cabideiro Alum. 820mm Alu 820mm percha Alu coat hanger 820mm	W 02x Cabideiro Alum. 399mm Alu 399mm percha Alu coat hanger 399mm	X 02x Perfil "H" 1856mm Perfil "H" 1856mm Profile "H" 1856mm
Y 01x Perfil "I" 360mm Perfil "I" 360mm Profile "I" 360mm	Z 06x Perfil Puxador Revestido MDF 780mm Perfil Tirador Revestido MDF 780mm Profile MDF 780mm Coated Handle	AA 06x Corrediça telescópica Corredera telescópica Telescopic slide	AB 24x Calço metal Alto (3mm) Calzado metálico Alto (3mm) High metal chock (3mm)	AC 24x Dobradiça metal 35mm Bisagra de metal 35mm 35mm metal hinge	AD 03x Sachê de cola Bolsa de pegamento Glue bag
AE 02x Giz de correção Tiza de corrección Chalk of correction	AF 07x Adesivo tapa parafuso 17mm Adhesivo tapón de tornillo 17mm Bolt cover adhesive 17mm	AG 37x Adesivo tapa parafuso 10mm Adhesivo tapón de tornillo 10mm Bolt cover adhesive 10mm	AH 01x Etiqueta resinada Henn Etiqueta resinada Henn Henn resin label		

Requisitos para montagem Requisitor para la montaje Assembly Requirements

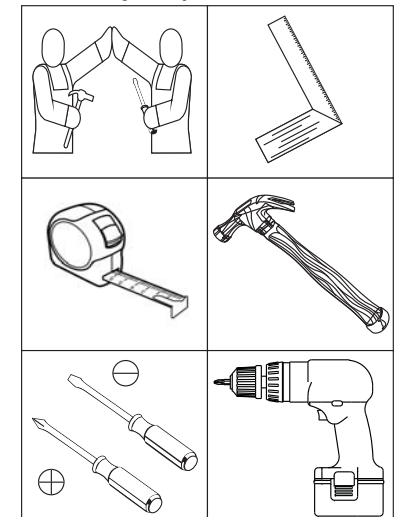

Imagens meramente ilustrativas
Imágenes meramente ilustrativas
Images for illustration only

AVISO
Para limpeza de seu móvel, use uma flanela seca ou umedecida, e não utilize produtos químicos que possam danificar seu produto.

SISTEMA DE MONTAGEM
O sistema de montagem dos produtos, funciona de acordo com a ordem crescente dos números indicados no desenho. Ex: 01, 02, 03, 04... até a conclusão da montagem.

ADVERTENCIA
Para limpieza de su móvil, use una flanela seca o húmeda, y no utilice productos químicos que puedan dañar su producto.

SISTEMA DE MONTAJE
El sistema de montaje de los productos funciona de acuerdo con el orden creciente de los números indicados en el dibujo. Ej.: 01, 02, 03, 04... hasta la conclusión del montaje.

NOTICE
To clean your furniture, use a dry or wet cloth, and do not use chemicals that may damage your product.

ASSEMBLY SYSTEM
The products' assembly system works according to the increasing order of the indicated numbers. For example: 01, 02, 03, 04 ... to the end of the assembly.

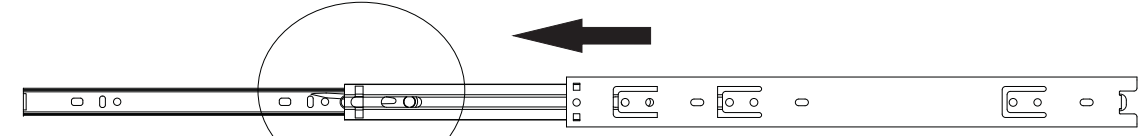
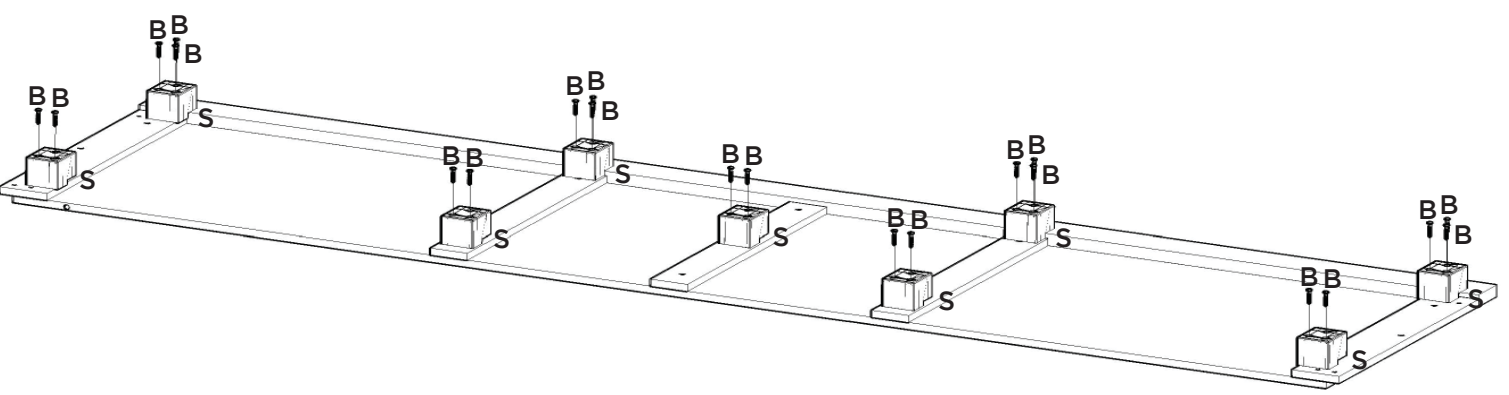
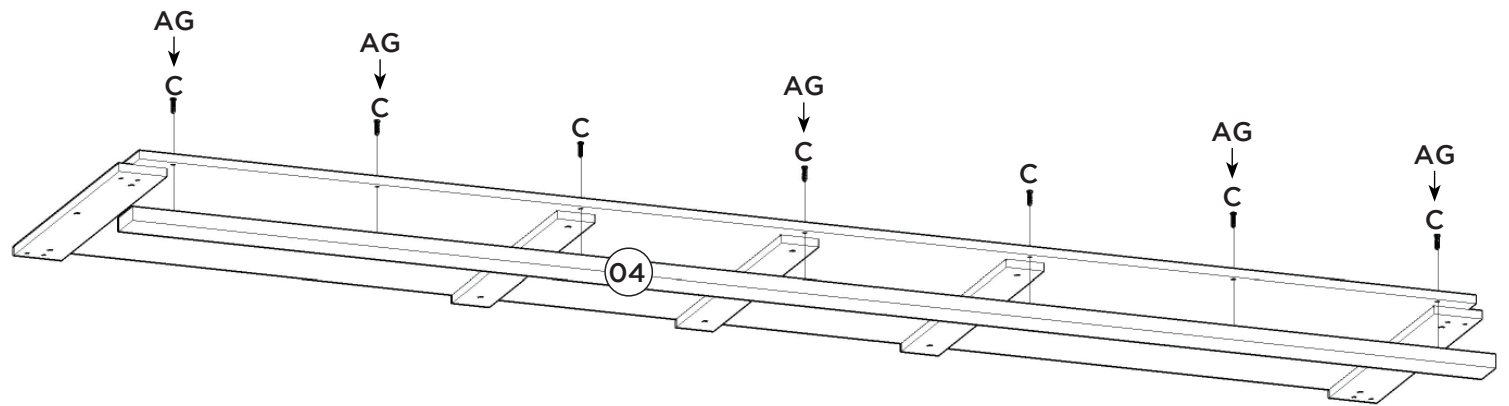
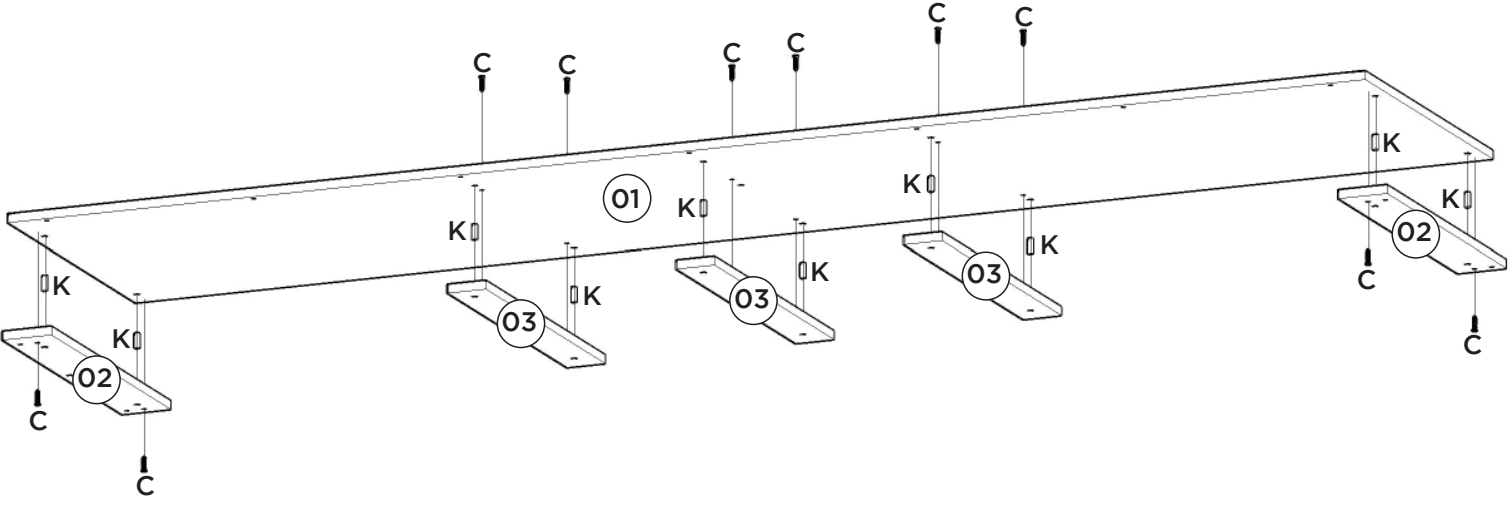

Para a desmontagem da correia siga a instrução ao lado.

Para el desmontaje seguimiento de diapositivas la instrucción siguiente a.

For the dismount of the sliding onem follows the instruction aside.

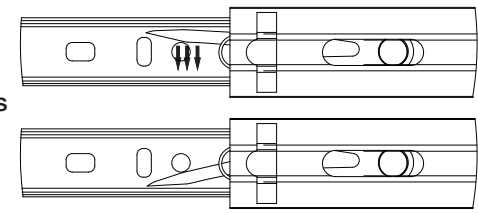

Fixar as correias nessas furações
Fijar las diapositivas de estos agujeros
Fix slides in these drillings

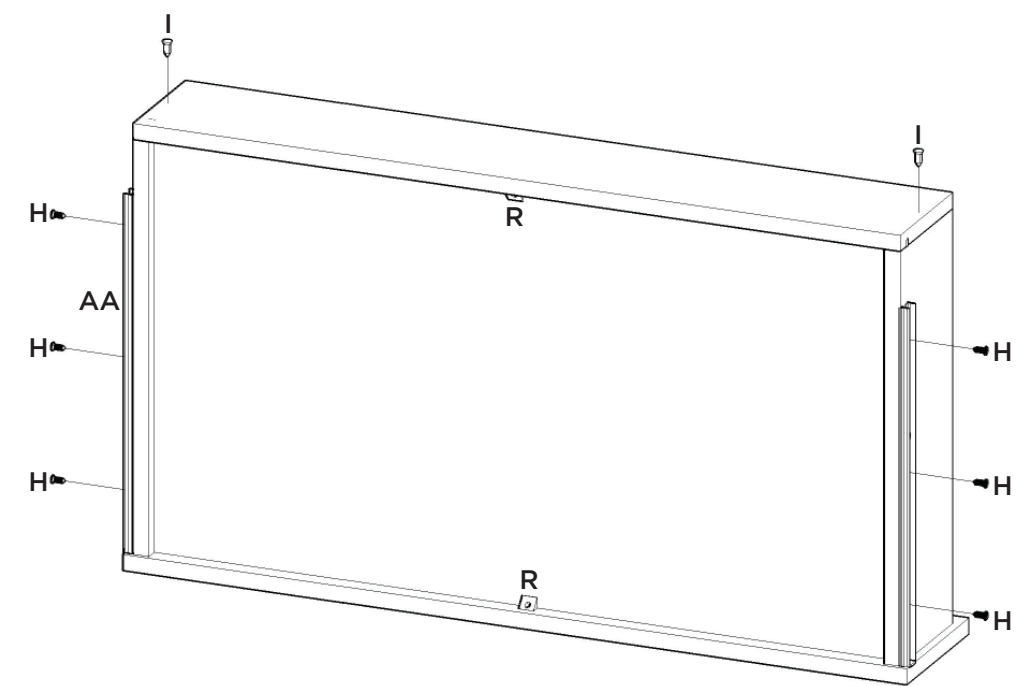
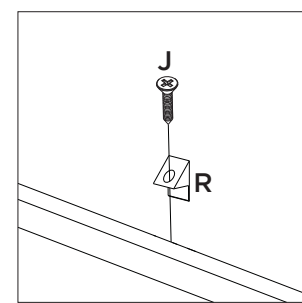
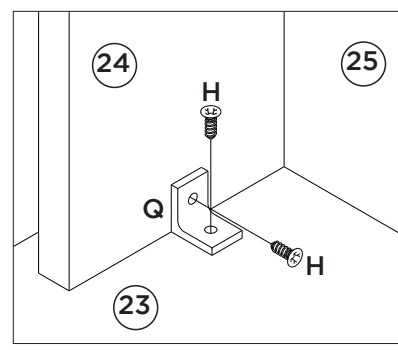
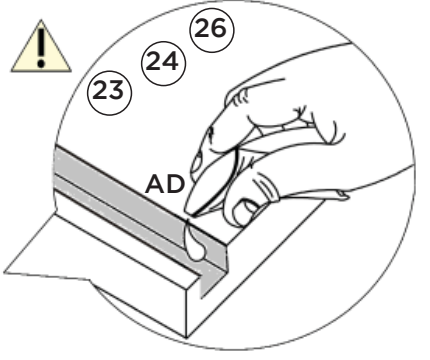
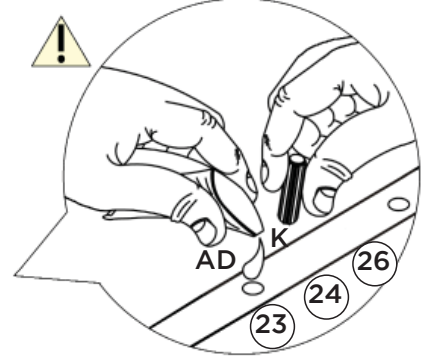
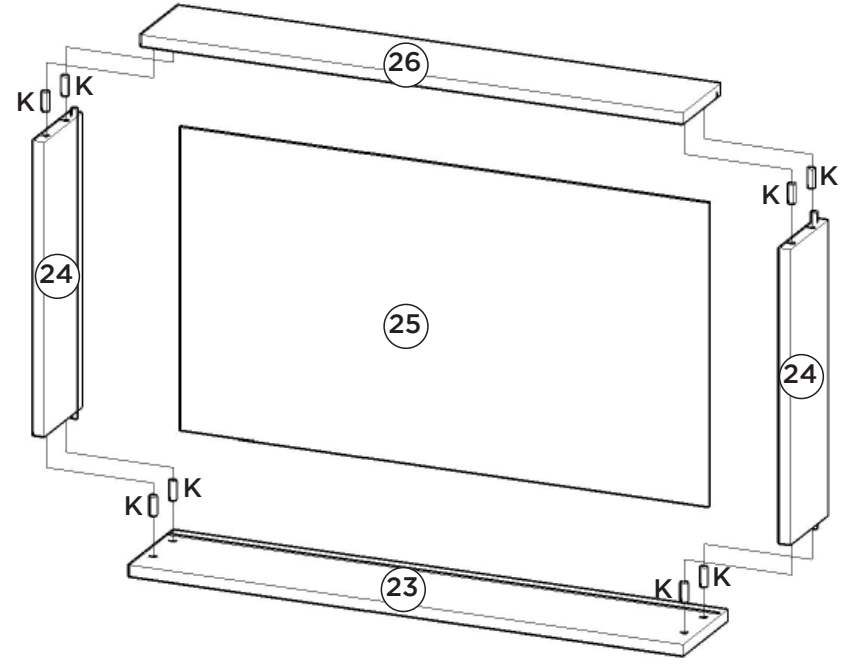

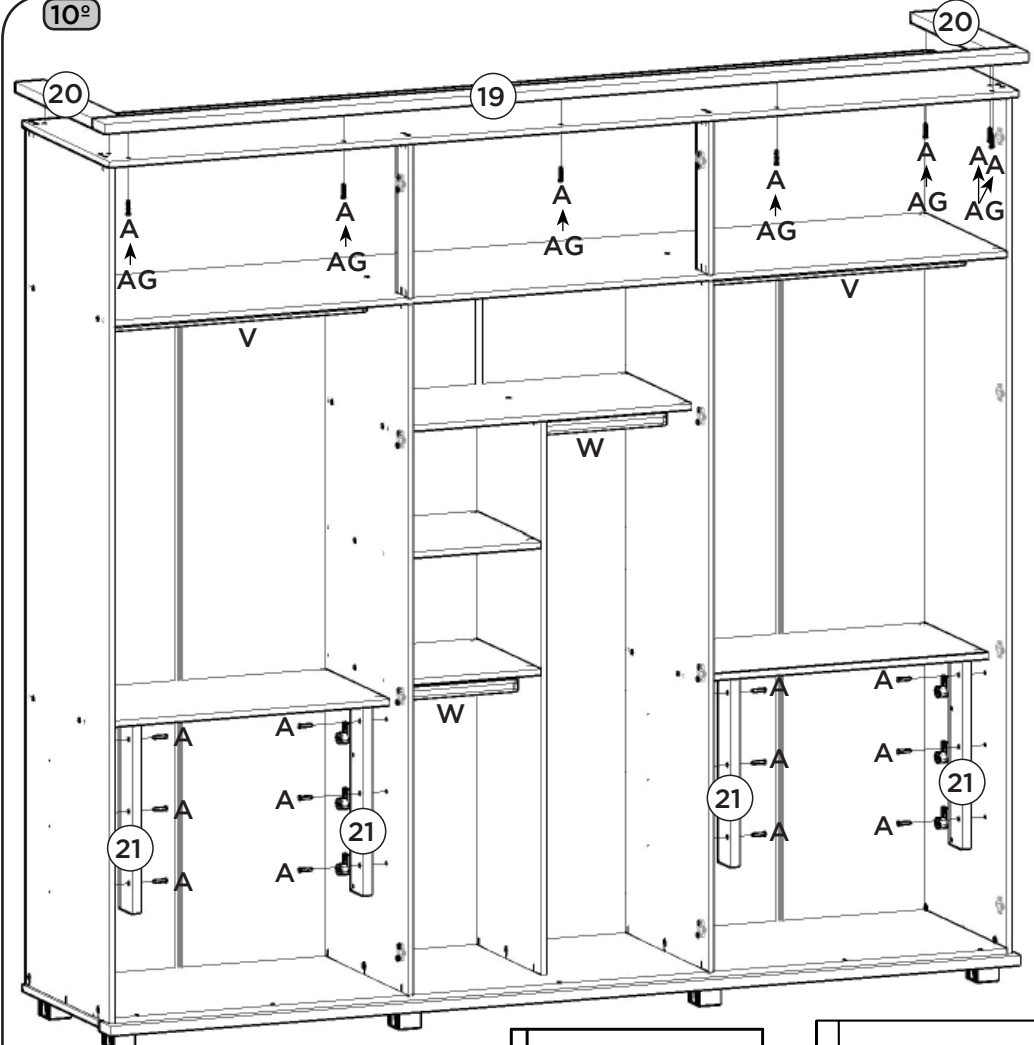

Vista superior para fixação da Moldura Frontal Superior (19)

Vista superior para colocar el marco frontal superior (19)

Top view for attaching the Upper Front Frame (19)

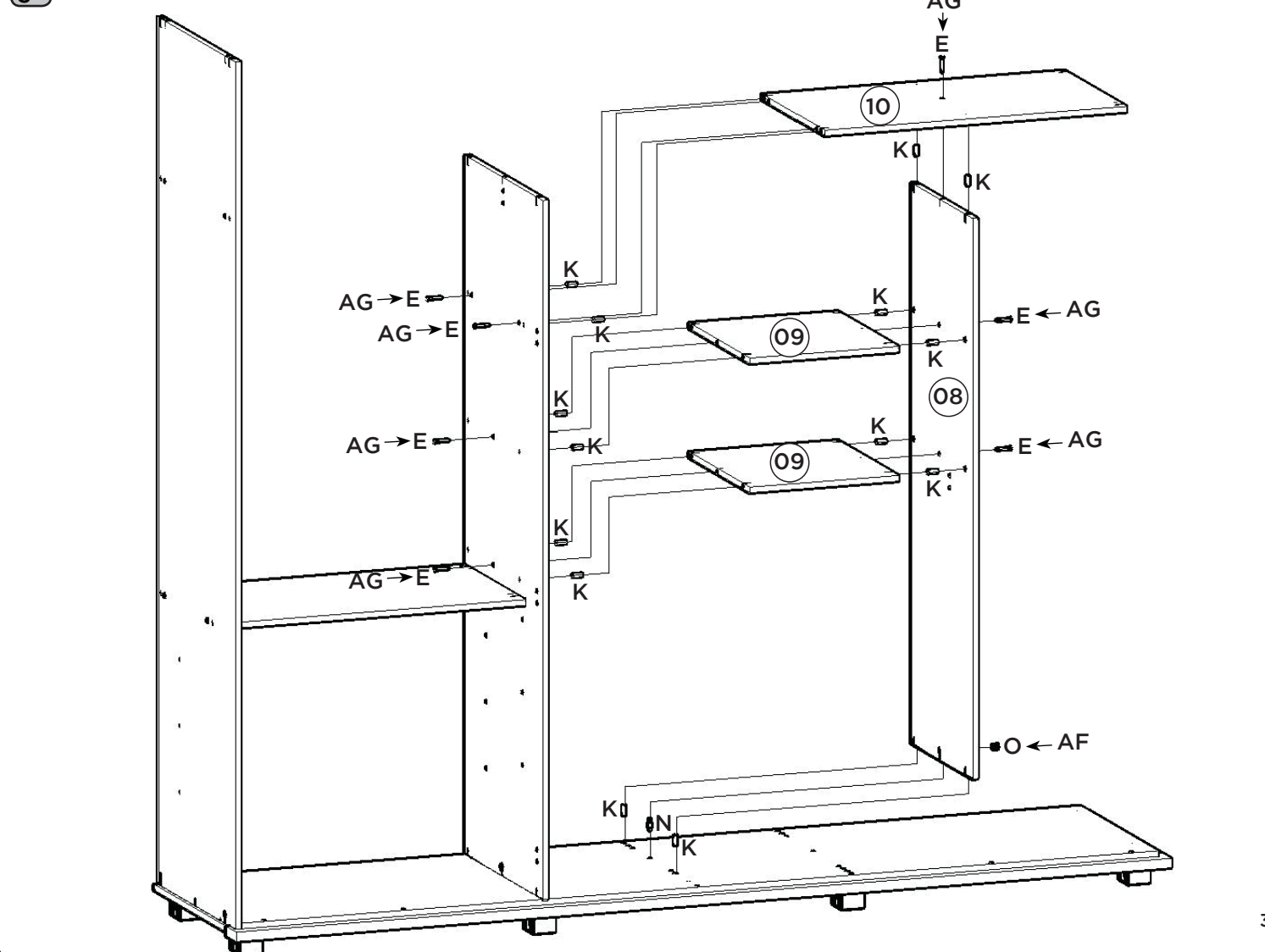
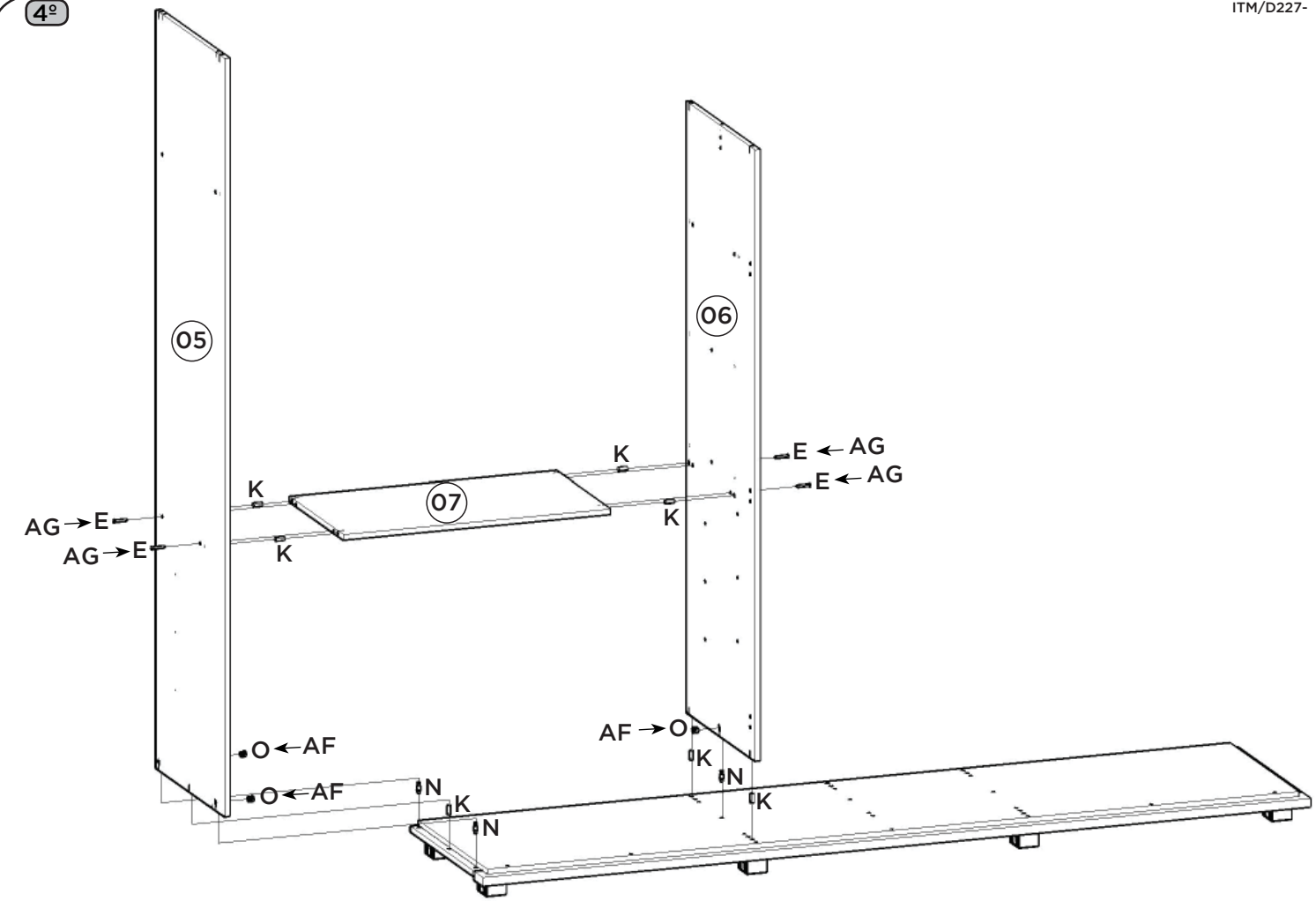
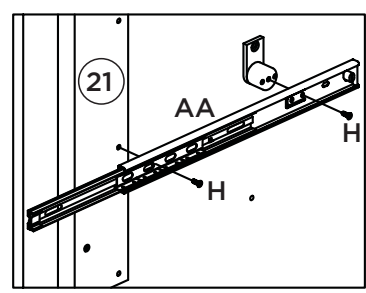
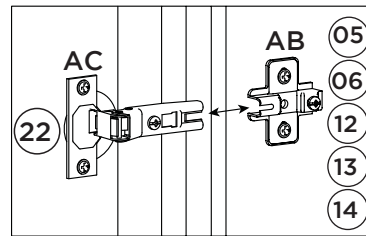
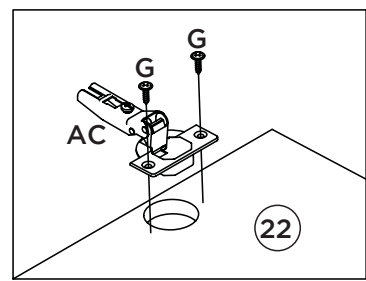
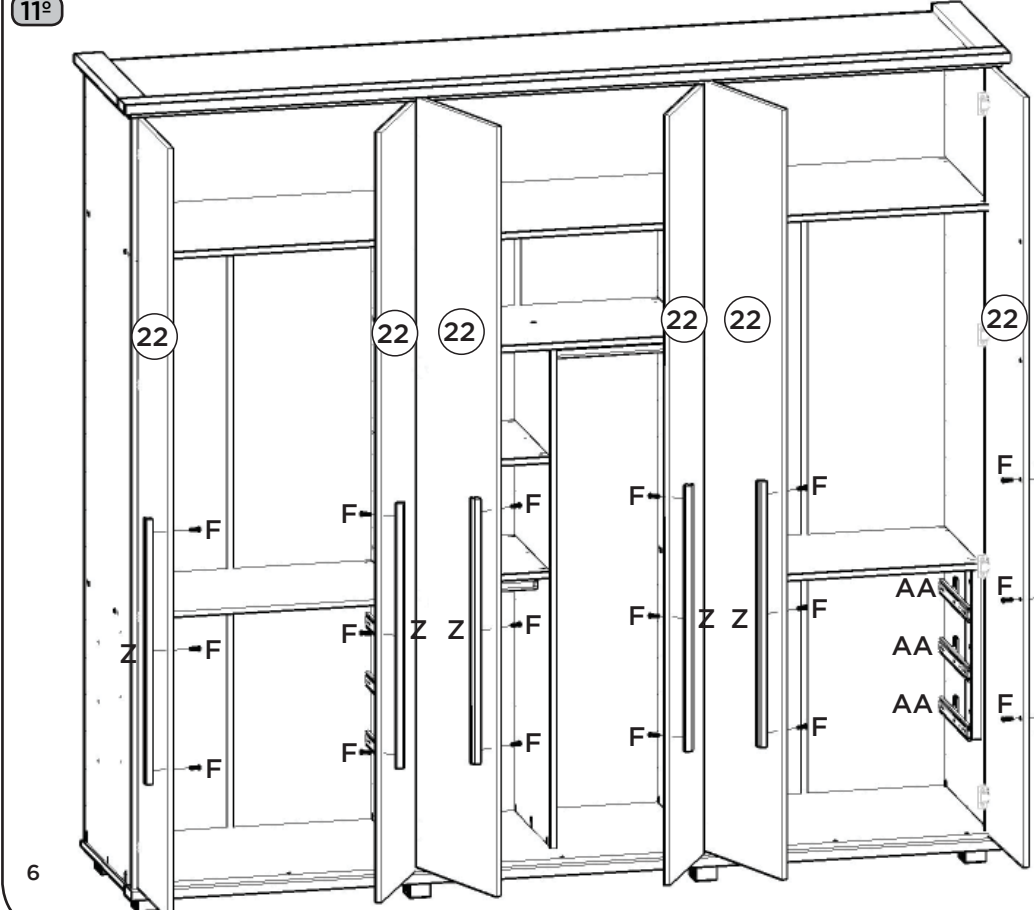
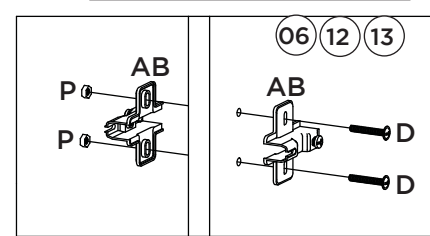
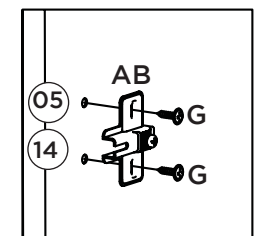
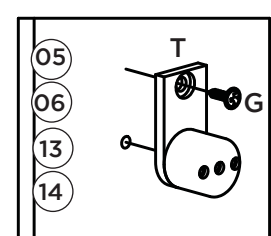
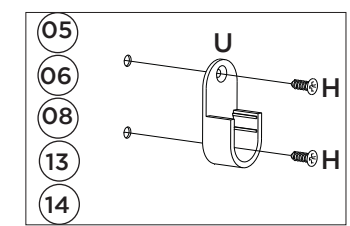
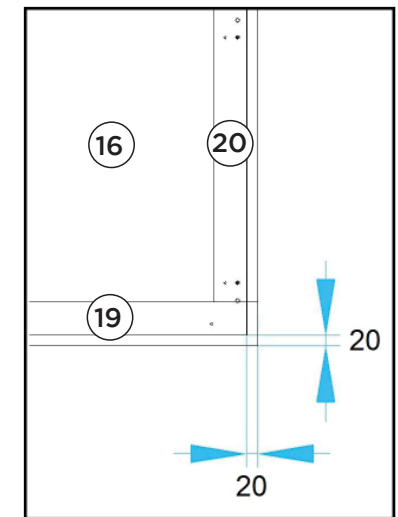

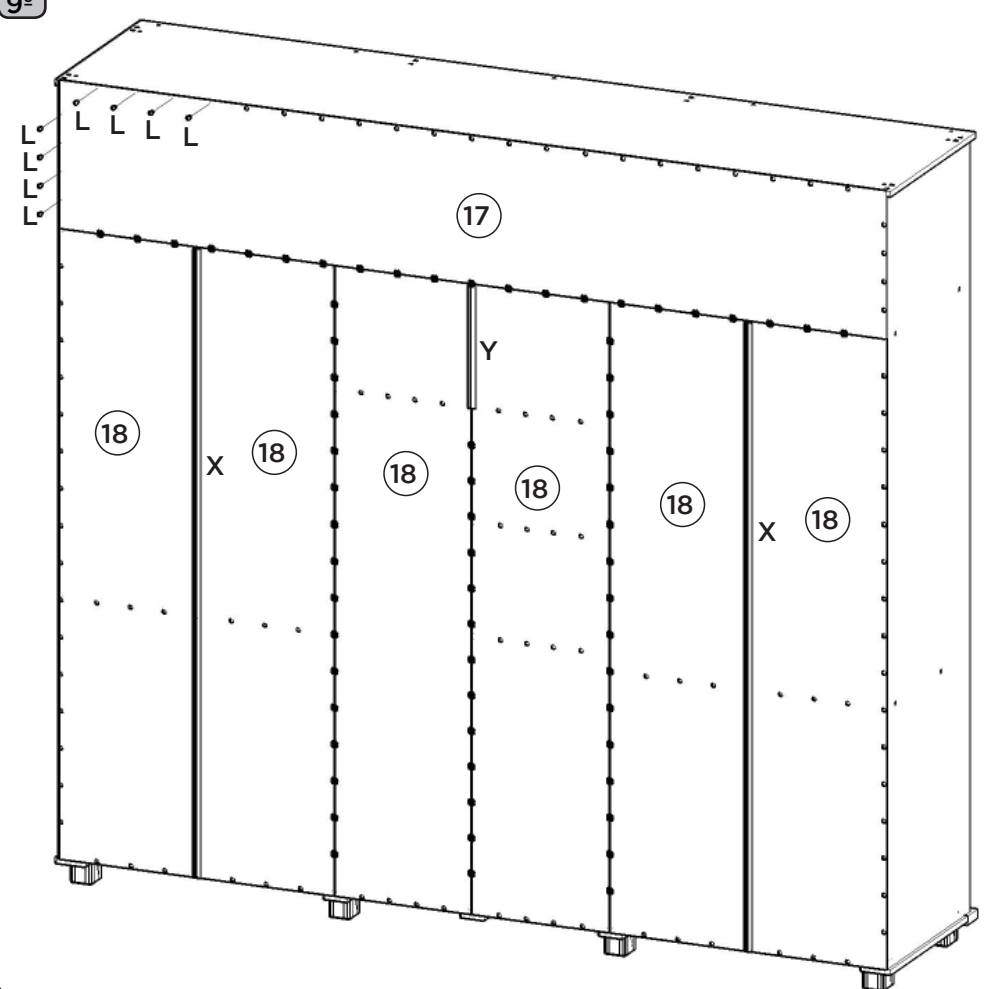
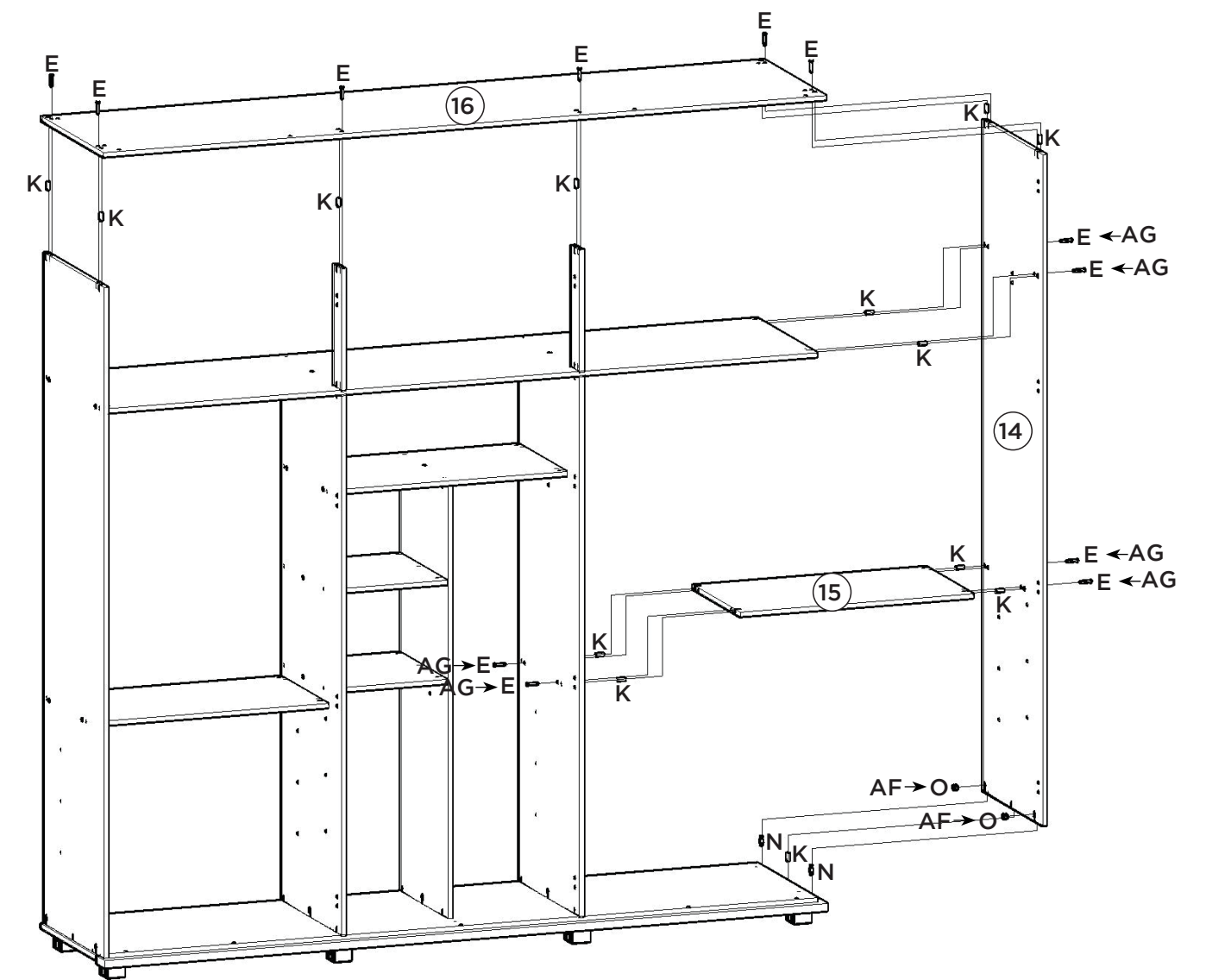
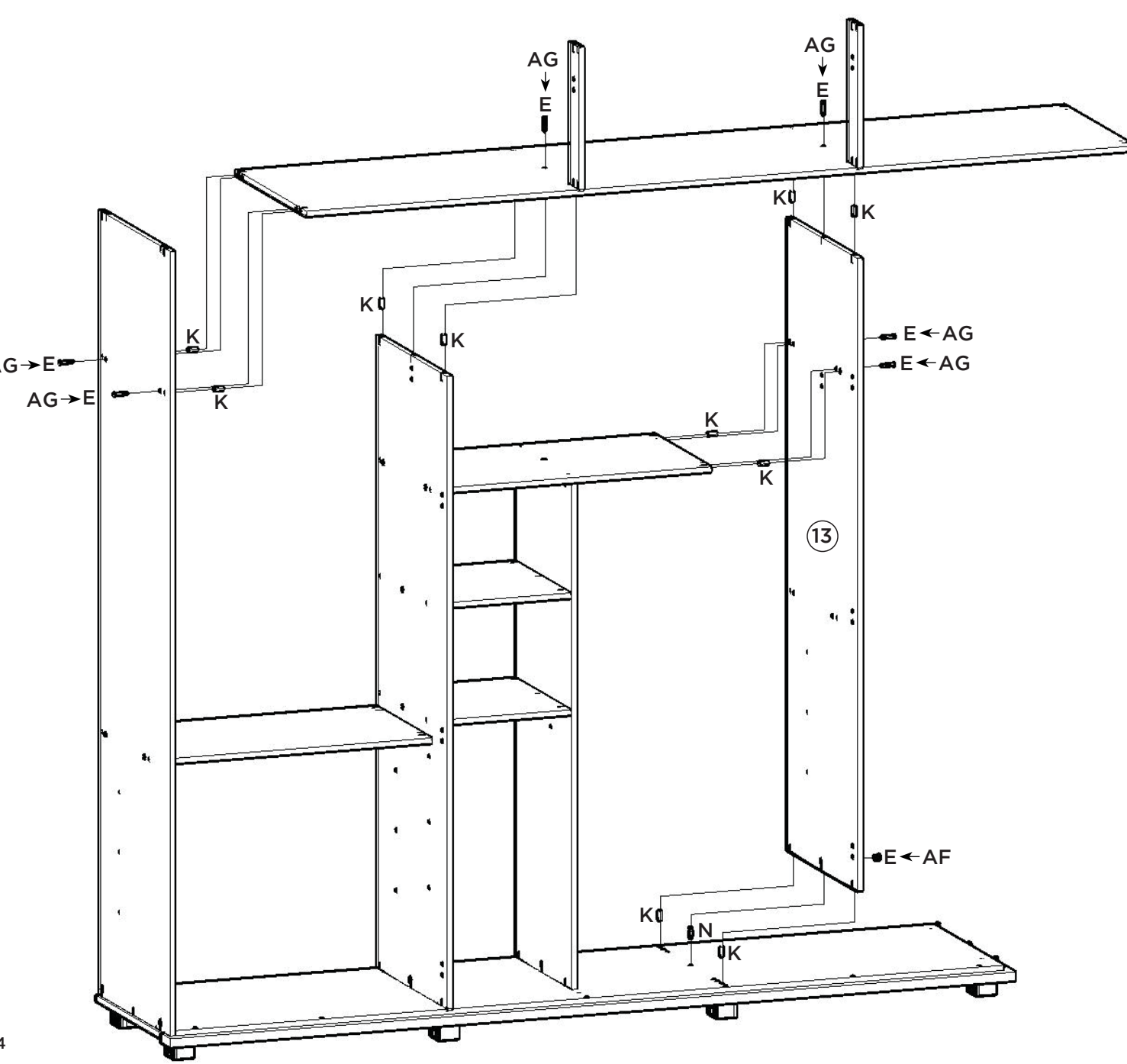
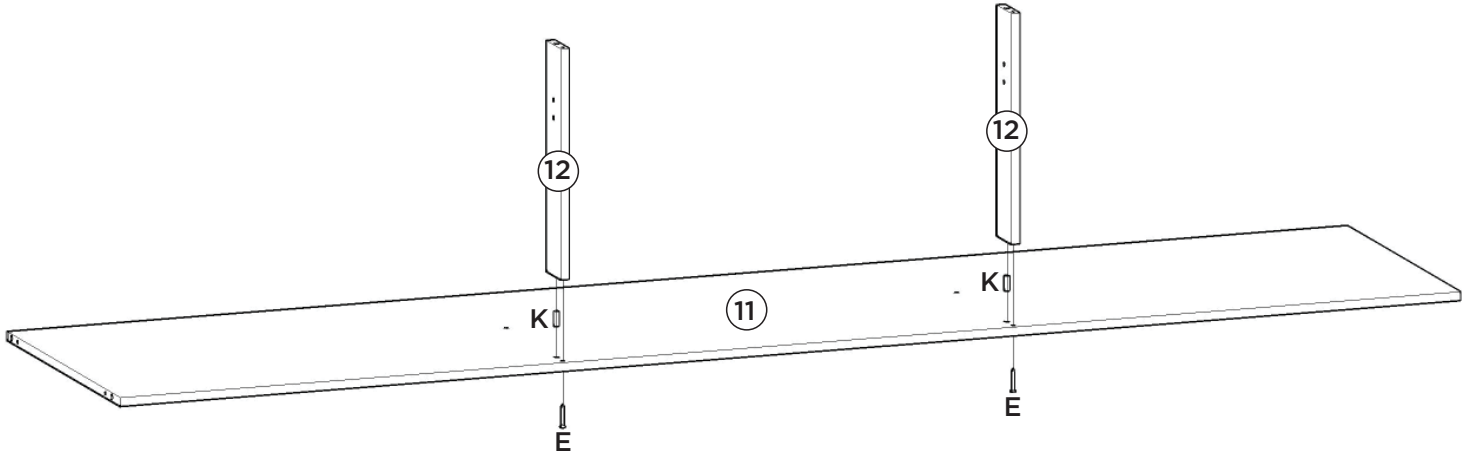

Colocar os pregos (L) a uma distância de 100mm de um para outro.

Coloque los clavos (L) a una distancia de 100 mm uno de otro.

Place the nails (L) at a distance of 100mm from one another.

