



**MANUAL DE MONTAGEM
ASSEMBLY INSTRUCTIONS
INSTRUCCIONES DE MONTAJE**

COD BR: BPP 63-205

Sumário Summary Resumen

Introdução Introduction Introducción	3
Antes de começar Before starting Antes de comenzar	4
Evite acidentes Avoid accidents Evitar accidentes	4
Dimensões e ferramentas Dimensions and tools Dimensiones y herramientas	5
Identificação das peças Identifying parts Identificación de las piezas	6
Acessórios incluídos na caixa Hardware included in box Accesorios incluidos en la caja	7
Montagem do móvel Furniture assembly Montaje del mueble	8

Introdução Introduction Introducción

Leia atentamente este manual e siga os passos indicados para que o produto não perca a garantia e também para uma perfeita montagem.

Read this manual and follow the steps in order to keep the guarantee and also for the perfect fit.

Lea este manual y siga los pasos para que el producto no pierda la garantía y también para el ajuste perfecto.

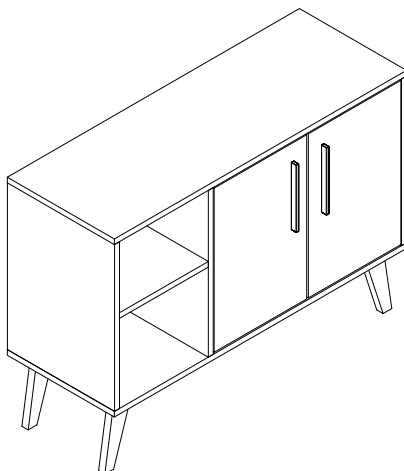

Antes de começar Before starting Antes de comenzar

Antes de começar a montagem prepare o ambiente, deixando-o completamente limpo e com bom espaço para iniciar o trabalho.

Prepare the room before starting the assembly, leaving it completely clean and the area in good condition to start the work.

Antes de comenzar el montaje preparar el ambiente, dejándolo completamente limpio y con bueno espacio para comenzar el trabajo.

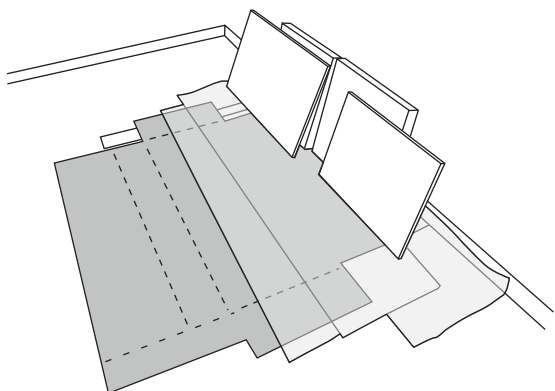

Utilize o papelão da própria embalagem para separar e apoiar as peças retiradas das caixas.

Use the cardboard of the packaging to separate and support the parts removed from the boxes.

Utilice el cartón de la embalaje para separar y apoyar las piezas desmontadas de las cajas.



Forre a área de montagem com um cobertor ou tapete. Assim, você evita avarias nas peças durante o processo de montagem.

Cover the assembly area with a blanket or carpet to avoid damaging the parts during the assembly process.

Cubrir la zona de ensamble con una manta o alfombra. De este modo, se evitan daños en las piezas durante el proceso de montaje.



Evite acidentes Avoid accidents Prevenir accidentes

Solicitamos observar atentamente as orientações de montagem como: fixação do produto na parede, colocação de cola em locais específicos necessários, o peso suportado pelo produto, etc...

We request you to carefully observe the assembly instructions as: fixing the product on the wall, adding glue in needed and specific places, product weight limit, etc.

Pedimos que lea atentamente las instrucciones, principalmente las informaciones de fijación del producto en la pared, colocación de pegamento en local específico y necesario, el peso soportado por el producto etc...

Não escale ou se apoie no móvel.

Do not climb or lean on the furniture.

No se suba ni se apoye en el mueble.

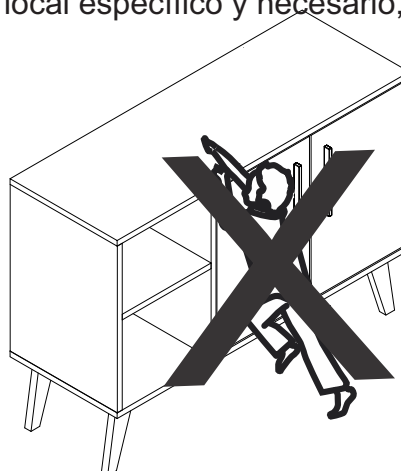

Dimensões e ferramentas
Dimensions and tools
Dimensiones y herramientas

Dimensões:

L: 901 A: 650 P: 330 mm

Dimensions:

W: 35.47 H: 25.59 D: 12.99 inches

Dimensiones:

L: 901 A: 650 P: 330 mm

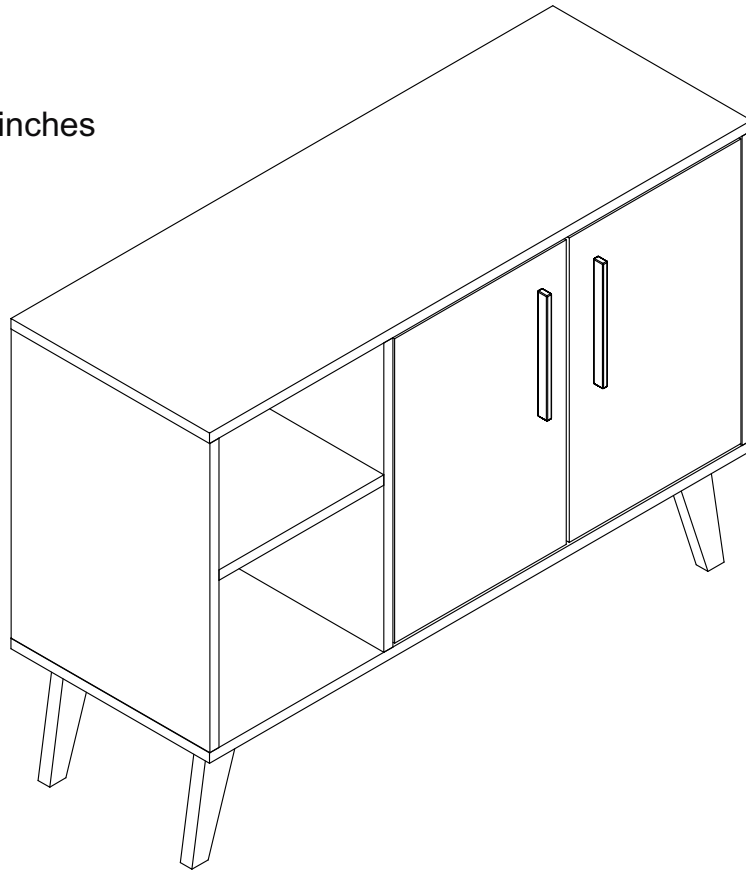

Limpeza
Cleanig
Limpieza



Pano levemente umedecido com água, seguido de pano seco, não utilizar produtos químico ou abrasivos.
Slightly dampened cloth and after a dry cloth, do not use chemicals or abrasives.
Solamente utilizar un paño húmedo y después un paño seco, no utilice productos químicos o abrasivos.

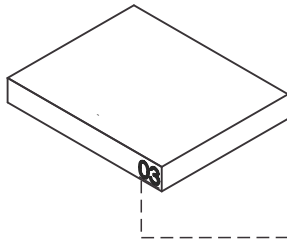

UTILIZE ALCOOL APENAS PARA REMOVER O NUMERO DAS PEÇAS
USE ALCOHOL ONLY TO REMOVE PART NUMBERS
UTILICE ALCOHOL SOLAMENTE PARA ELIMINAR EL NUMERO DE LAS PIEZAS

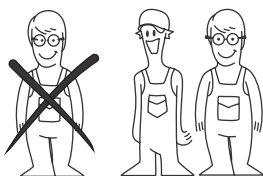

Para facilitar a montagem, utilize uma parafusadeira elétrica.
To improve assembly, use an eletronic screwdriver.
Para facilitar el armado, utilice un destornillador eléctrico.

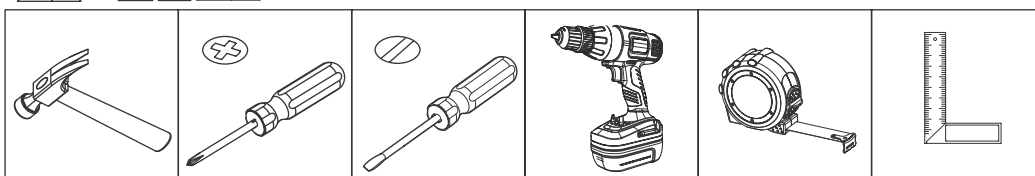

COD BR: BPP 63-205

PEÇA	DESCRIÇÃO	QUANT.	PART DESCRIPTION	QTY	PIEZA	DESCRIPCIÓN	CANTIDAD	
001	BASE	1	001	BASE	1	001	BASE	1
002	TAMPO	1	002	TOP	1	002	TAPA	1
003	LATERAL ESQUERDA	1	003	LEFT SIDE	1	003	LATERAL IZQUIERDA	1
004	LATERAL DIREITA	1	004	RIGHT SIDE	1	004	LATERAL DERECHA	1
005	DIVISÓRIA	1	005	PARTITION	1	005	PARTICIÓN	1
006	PORTA ESQUERDA	1	006	LEFT DOOR	1	006	PUERTA IZQUIERDA	1
007	PORTA DIREITA	1	007	RIGHT DOOR	1	007	PUERTA DERECHA	1
008	PRATELEIRA MAIOR	1	008	LONGER SHELF	1	008	REPISA MAYOR	1
009	PRATELEIRA MENOR	1	009	LOWER SHELF	1	009	REPISA MENOR	1
010	COSTA	2	010	BACK	2	010	REVÉS	2
011	PÉS	4	011	FEET	4	011	PIES	4

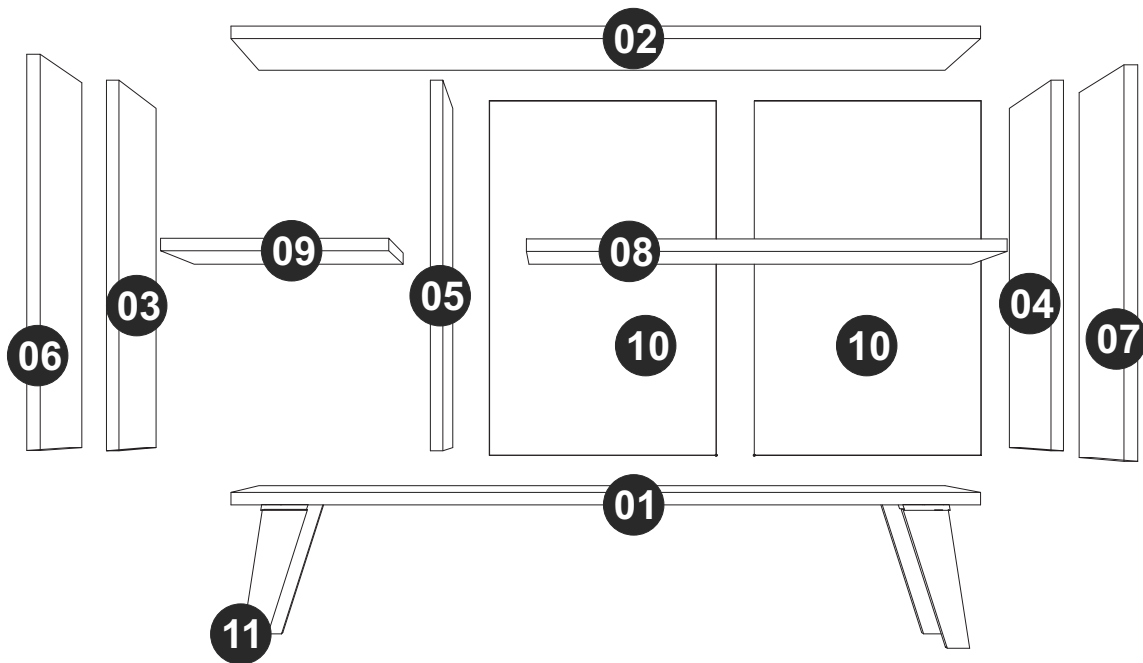

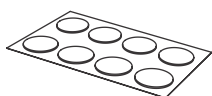

TAPA FUROS x 6
STICKER x 6
TAPAS PLÁSTICAS x 6



EF 000557 x 16
4X16



EF 000216 X 6



EF 000033 x 12
8x30

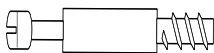

EF 000094 X 6



EF 000132 x 6
4x50 CC

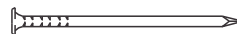

EF 000168 X 30
10x10 C/C



GIZ x 01
CHALK x 01
TIZA x 01

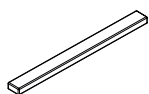

PUXADOR x 2
HANDLE x 2
MANIJA x 2



SUPORTE PLÁSTICO x 8
PLÁSTIC SUPPORT x 8
SOPORTE PLASTICOS x 8



EF 000106 x 16
3,5x14



EF 000025 X 4

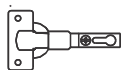

EF 000043 X 4

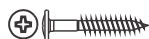

EF 000112 x 4
3,5x 25 CF

Utilize para medir as ferragens.

Utilice para medir el herraje.

Use for measuring the hardware.

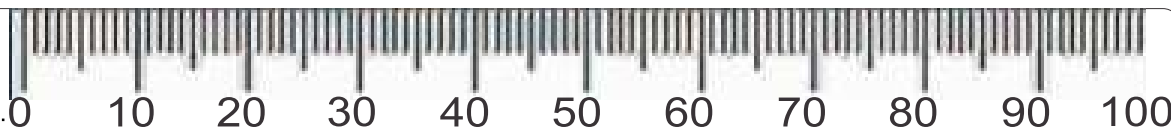

Garantia (exclusivo para o Brasil/exclusivo de Brasil/exclusive to Brazil):

A garantia dos produtos fabricados pela BRV Móveis, abrange eventuais defeitos-vícios de fabricação, no prazo estabelecido pelo código de Defesa do Consumidor, em seu artigo 26.II. o qual prevê a garantia de 90 (noventa) dias.

A = 10 KG - 22.04LB

B = 6KG - 13.22LB

C = 3KG - 6.61LB

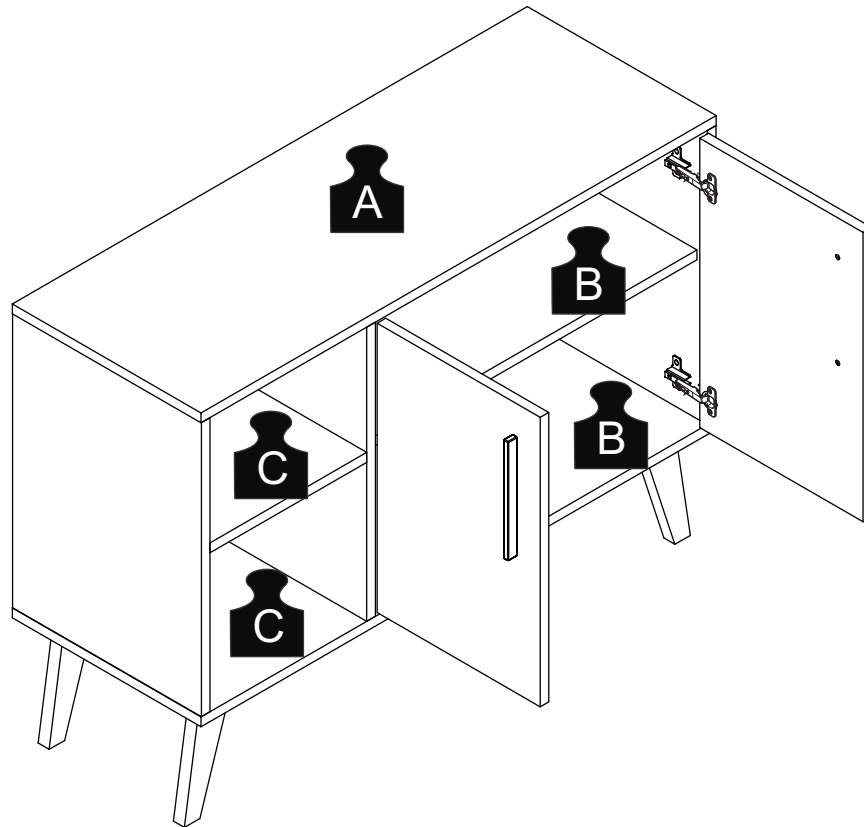

PASSO 1 / STEP 1 / PASO 1

Fixe a ferragem EF 000094 nas pré-furações indicadas na peça 02.

Fix hardware EF 000094 at pre-drilled holes indicated at piece 02.

Fije el herraje EF000094 el los huecos ya marcados en la pieza 02.

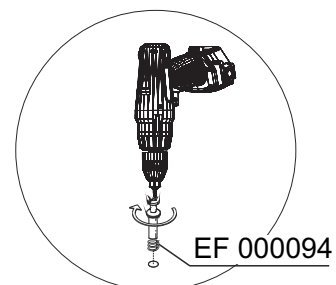
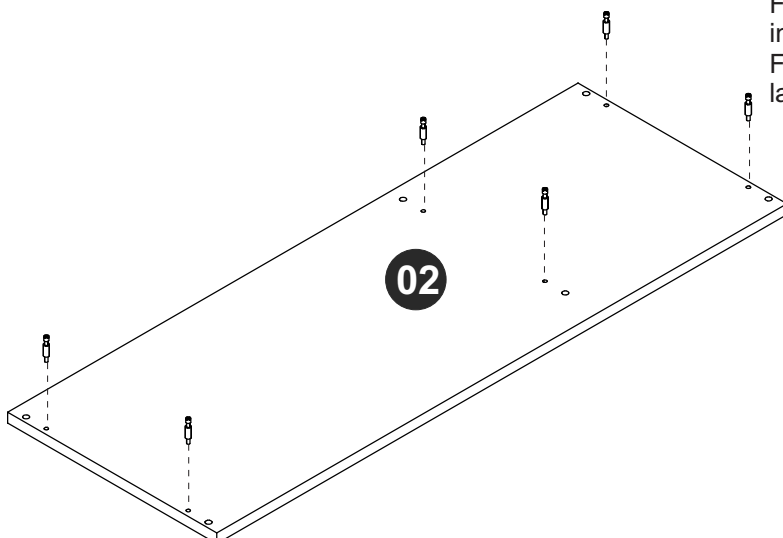

PASSO 2 / STEP 2 / PASO 2

Insira a ferragem EF 000033 e o suporte plástico nas peças 03, 04 e 05.
Insert hardware EF 000033 and the plastic support into pieces 03, 04 and 05.
Añade el herraje EF 000033 y el soporte plástico en las piezas 03, 04 y 05.

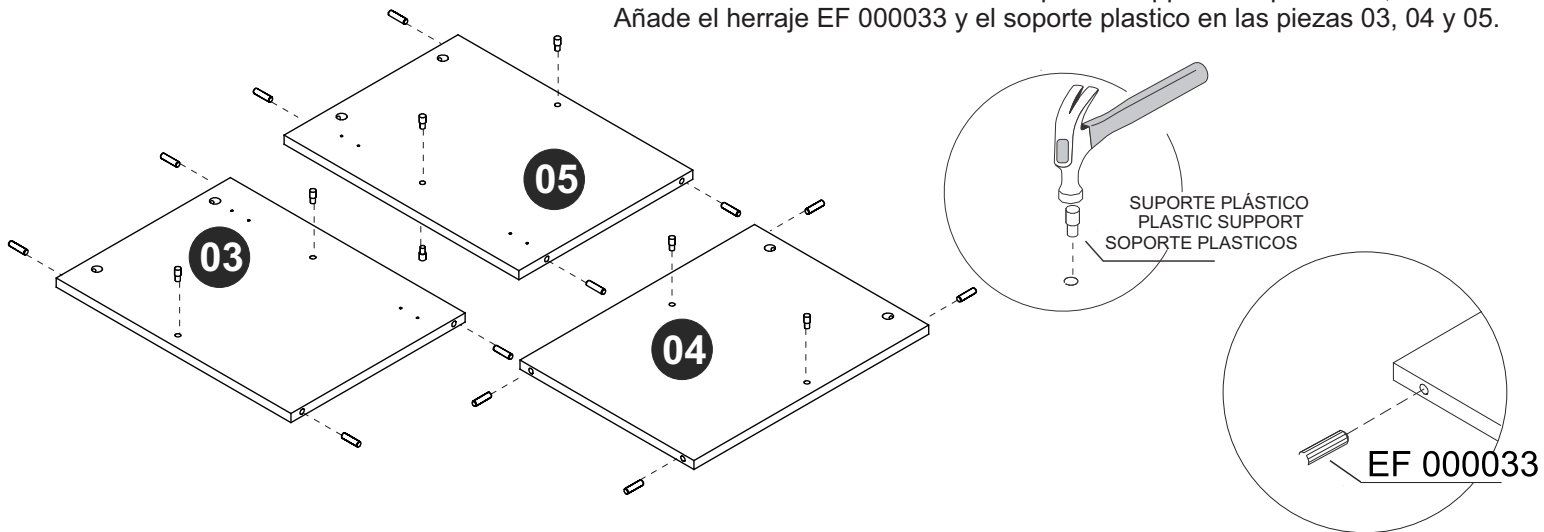

PASSO 3 / STEP 3 / PASO 3

Fixe o puxador na peça 06 e 07 utilizando a ferragem EF 000112. Fixe a ferragem EF 000043 usando a ferragem EF 000106.
Attach the handle in pieces 06 and 07 using hardware EF 000112. Attach hardware EF 000043 using hardware EF 000106.
Fije la manija en las piezas 06 y 07 utilizando el herraje EF 000112. Fije el herraje EF 000043 utilizando el herraje EF 000106.

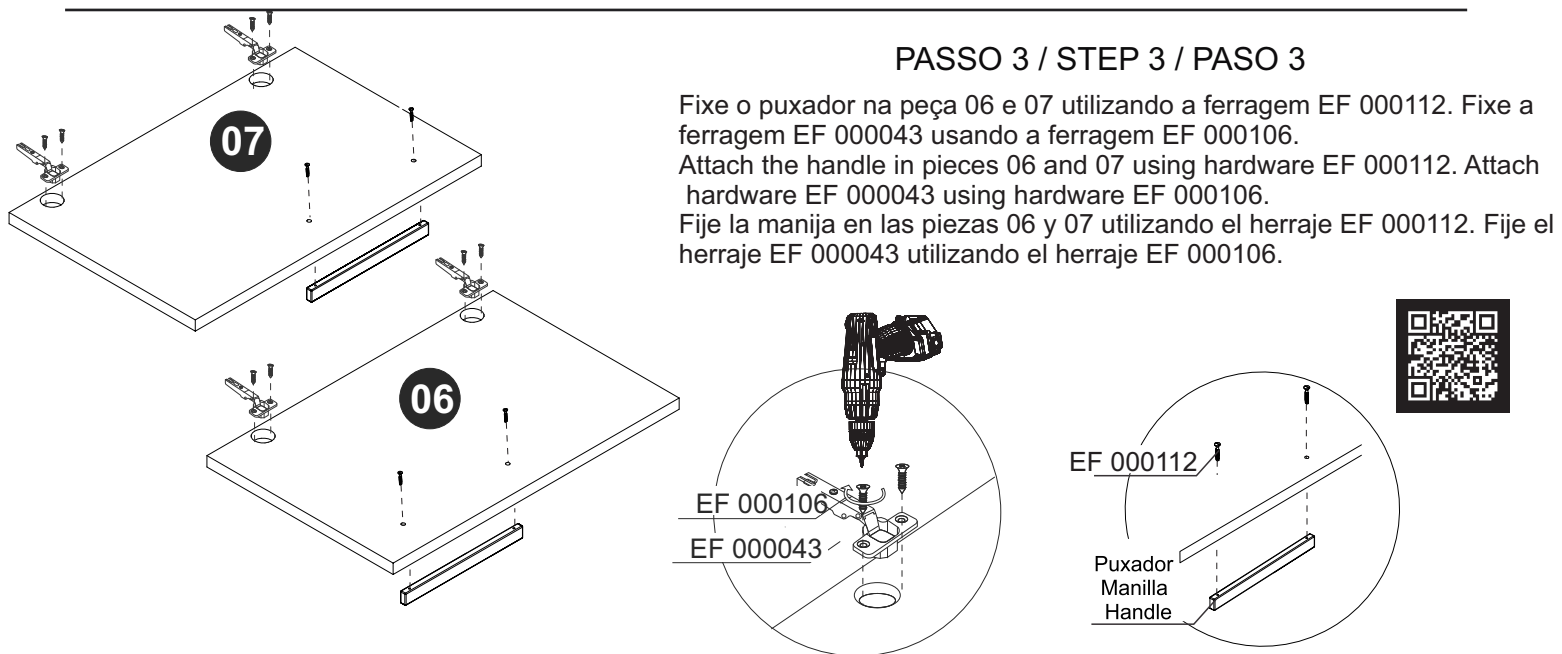

PASSO 4 / STEP 4 / PASO 4

Fixe a ferragem EF 000025 nas peças 04 e 05 usando a ferragem EF 000106.
Attach hardware EF 000025 in pieces 04 and 05 using hardware EF 000106.
Fije el herraje EF 000025 en las piezas 04 y 05 utilizando el herraje EF 000106.

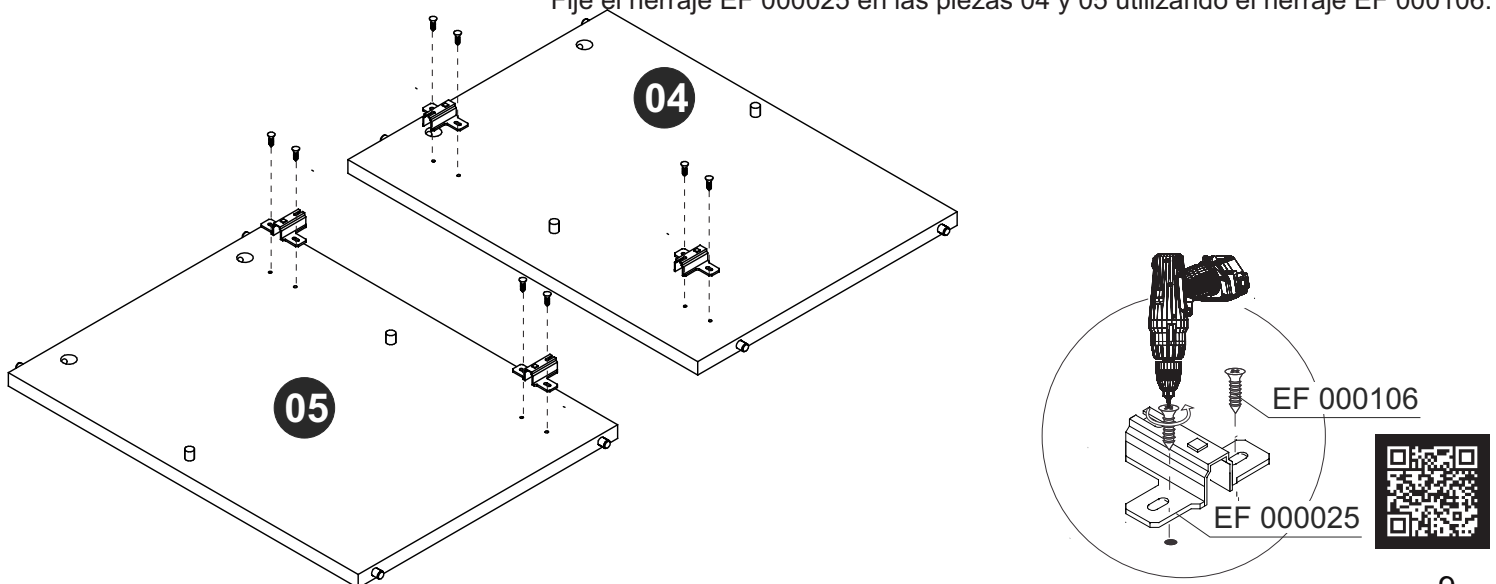

PASSO 5 / STEP 5 / PASO 5

Conecte as peças 02, 03, 04 e 05, insira a ferragem EF 000216 e gire para apertar.
Connect pieces 02, 03, 04 and 05, Insert hardware EF 000216 and turn to tighten.
Junte las piezas 02, 03, 04 y 05, Añade el herraje EF 000216 y gire para apretar.

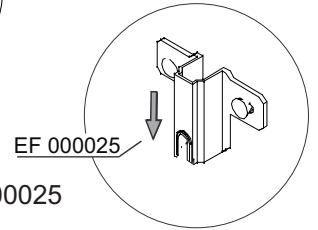
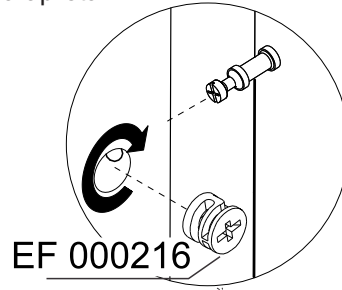
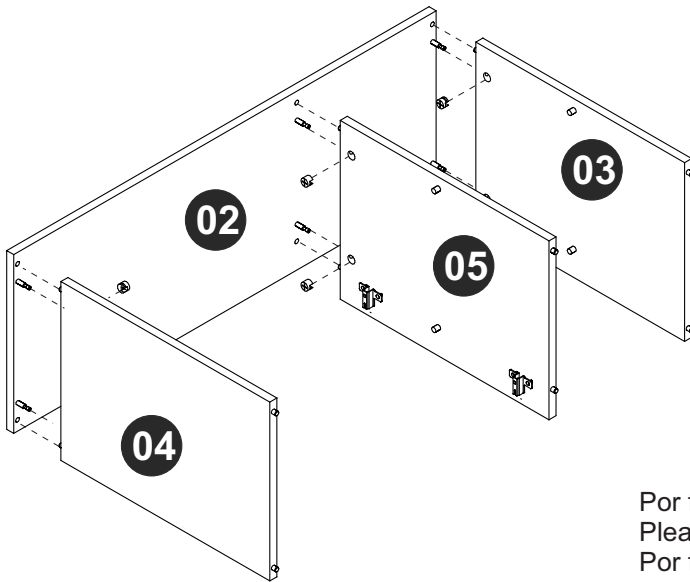

Por favor, observe a posição da ferragem EF 000025
Please, note hardware EF 000025 position.
Por favor, observe la posición del herraje EF000025.

PASSO 6 / STEP 6 / PASO 6

Fixe os pés (peça 11) na peça 01 utilizando a ferragem EF 000557.
Fix feet (piece 11) at piece 01 using hardware EF 000557.
Fije los pies (pieza 11) en la pieza 01 utilizando el herraje EF 000557.

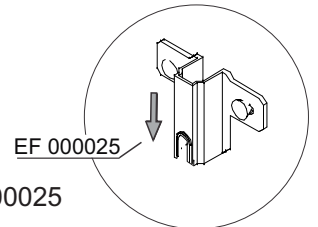
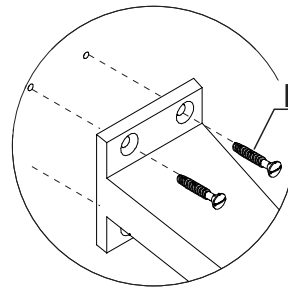
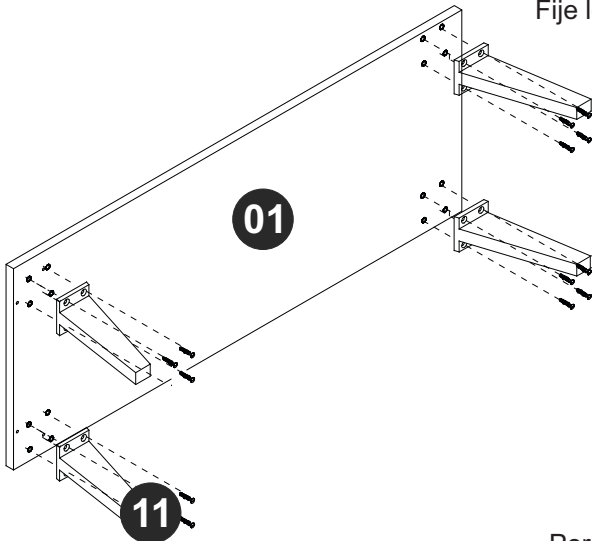

Por favor, observe a posição da ferragem EF 000025
Please, note hardware EF 000025 position.
Por favor, observe la posición del herraje EF000025.

PASSO 7 / STEP 7 / PASO 7

Conecte as partes montadas nos passos 05 e 06 utilizando a ferragem EF 000132.
Connect the parts assembled in the step 05 and 06 using hardware EF 000132.
Junte las partes armadas en los pasos 05 y 06 utilizando el herraje EF 000132.

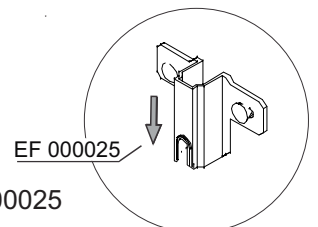
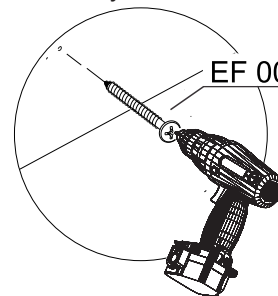
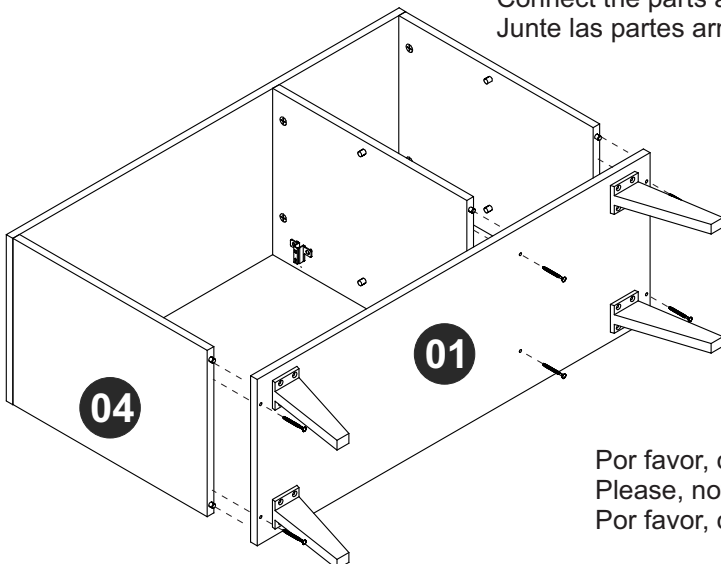

Por favor, observe a posição da ferragem EF 000025
Please, note hardware EF 000025 position.
Por favor, observe la posición del herraje EF000025.

PASSO 8 / STEP 8 / PASO 8

Fixe as peças 10 ao móvel utilizando a ferragem EF 000168.
Fix pieces 10 at the furniture using hardware EF 000168.
Fije las piezas 10 al mueble utilizando el herraje EF 000168.

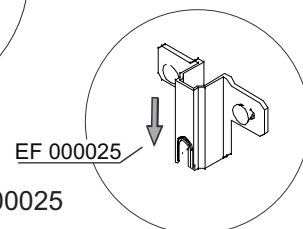
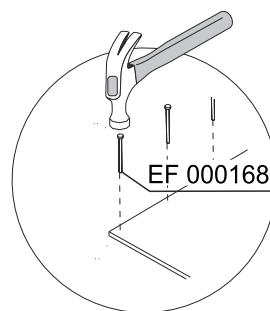
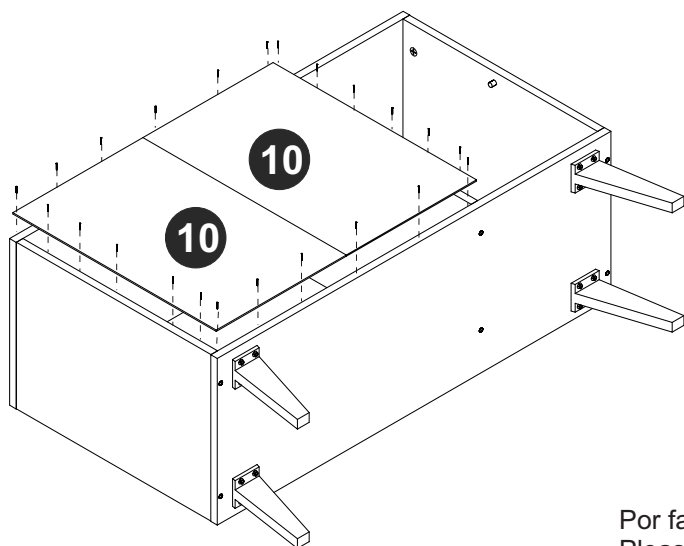

Por favor, observe a posição da ferragem EF 000025
Please, note hardware EF 000025 position.
Por favor, observe la posición del herraje EF000025.

PASSO 9 / STEP 9 / PASO 9

Encaixe as peças 08 e 09 de acordo com a imagem.
Fit pieces 08 and 09 according the image.
Encaje las piezas 08 y 09 de acuerdo con la imagen.

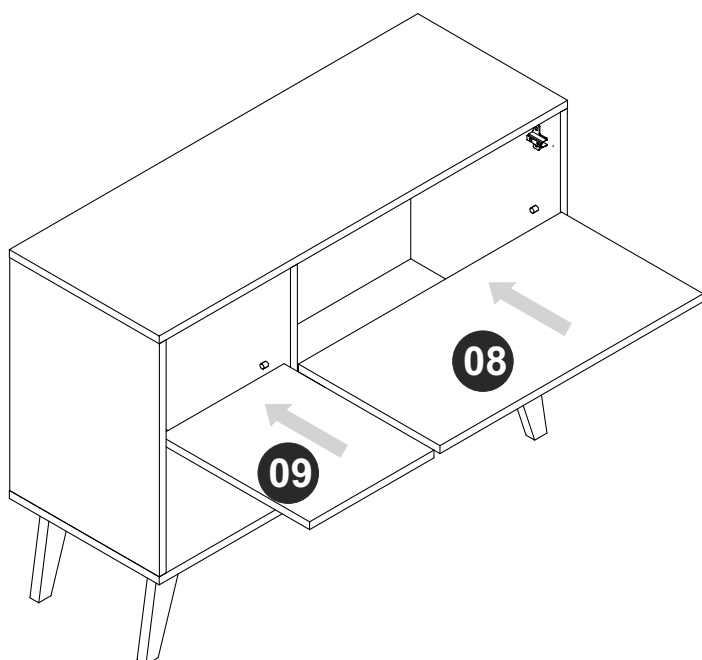

PASSO 10 / STEP 10 / PASO 10

Fixe as peças 06 e 07 ao móvel montado.
Fix pieces 06 and 07 at the assembled furniture.
Fije las piezas 06 y 07 al mueble armado.

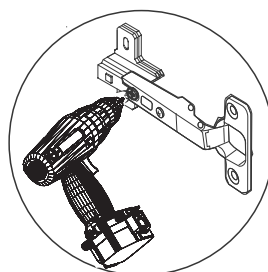
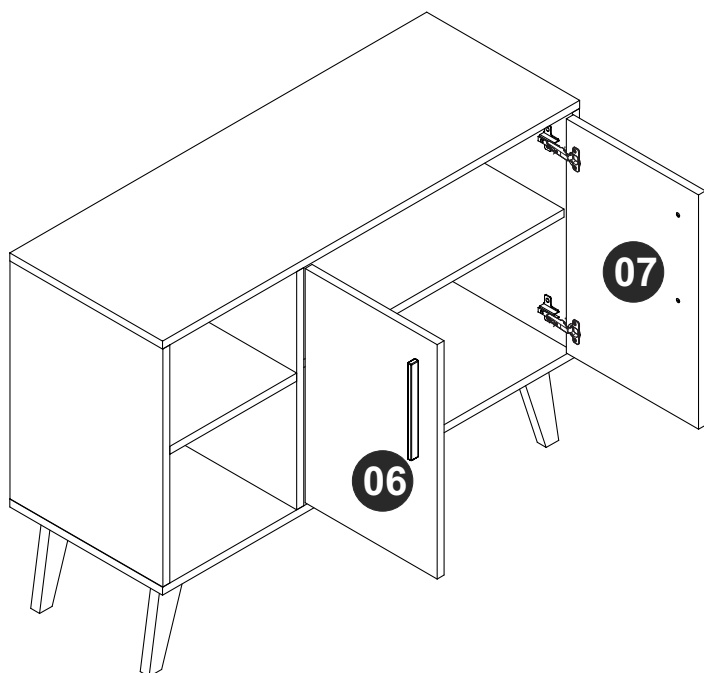

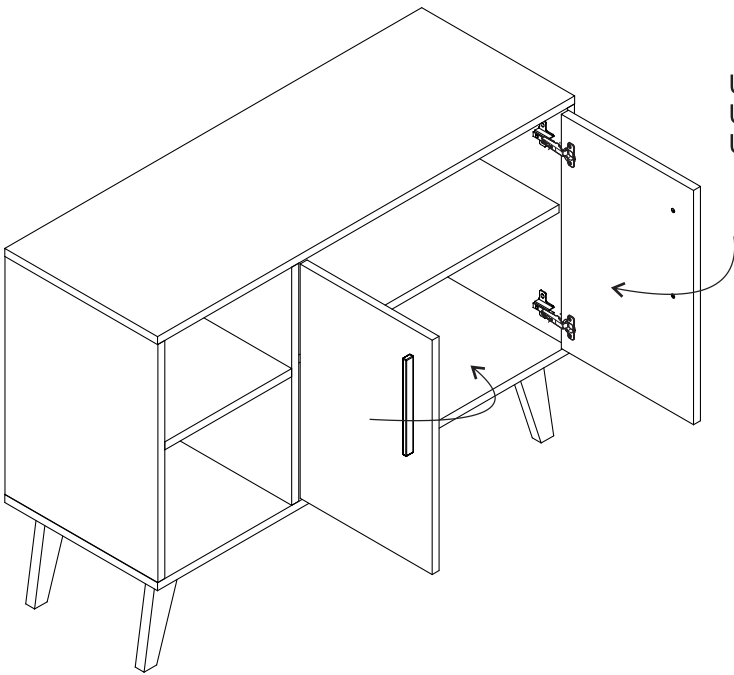

PASSO 11 / STEP 11 / PASO 11

Utilize o tapa furos para cobrir os parafusos aparentes.
Use the sticker to cover the apparent screws.
Utilice los tapa huecos para cubrir los tornillos aparentes.

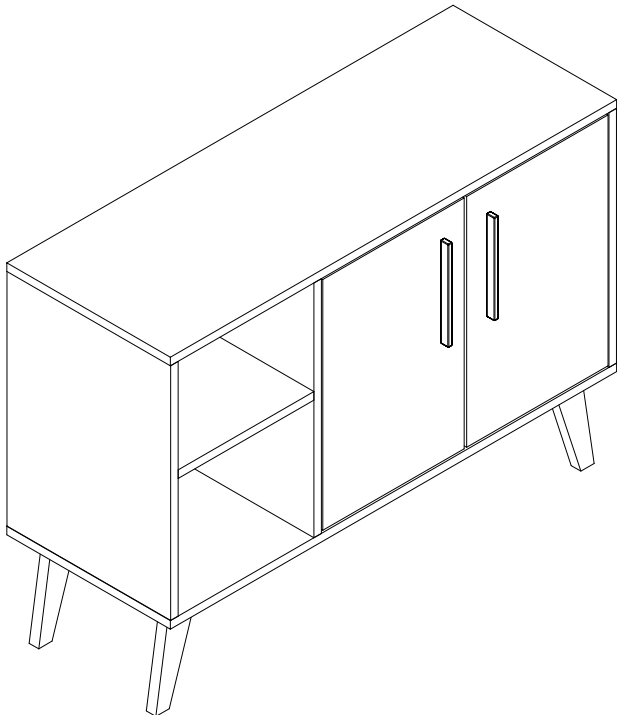
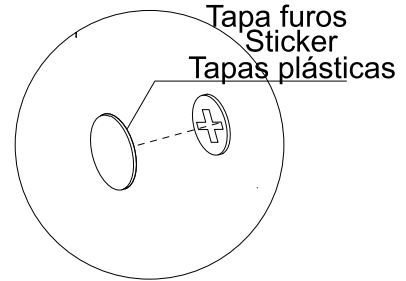

PASSO 12 / STEP 12 / PASO 12

Utilize o giz para dar o acabamento final ao produto.
Use the chalk to give the final finish on the product.
Utilize la tiza para dar el acabado final al producto.

