

MANUAL DE MONTAGEM - ROUPEIRO 3 PORTAS PHOENIX/TORONTO

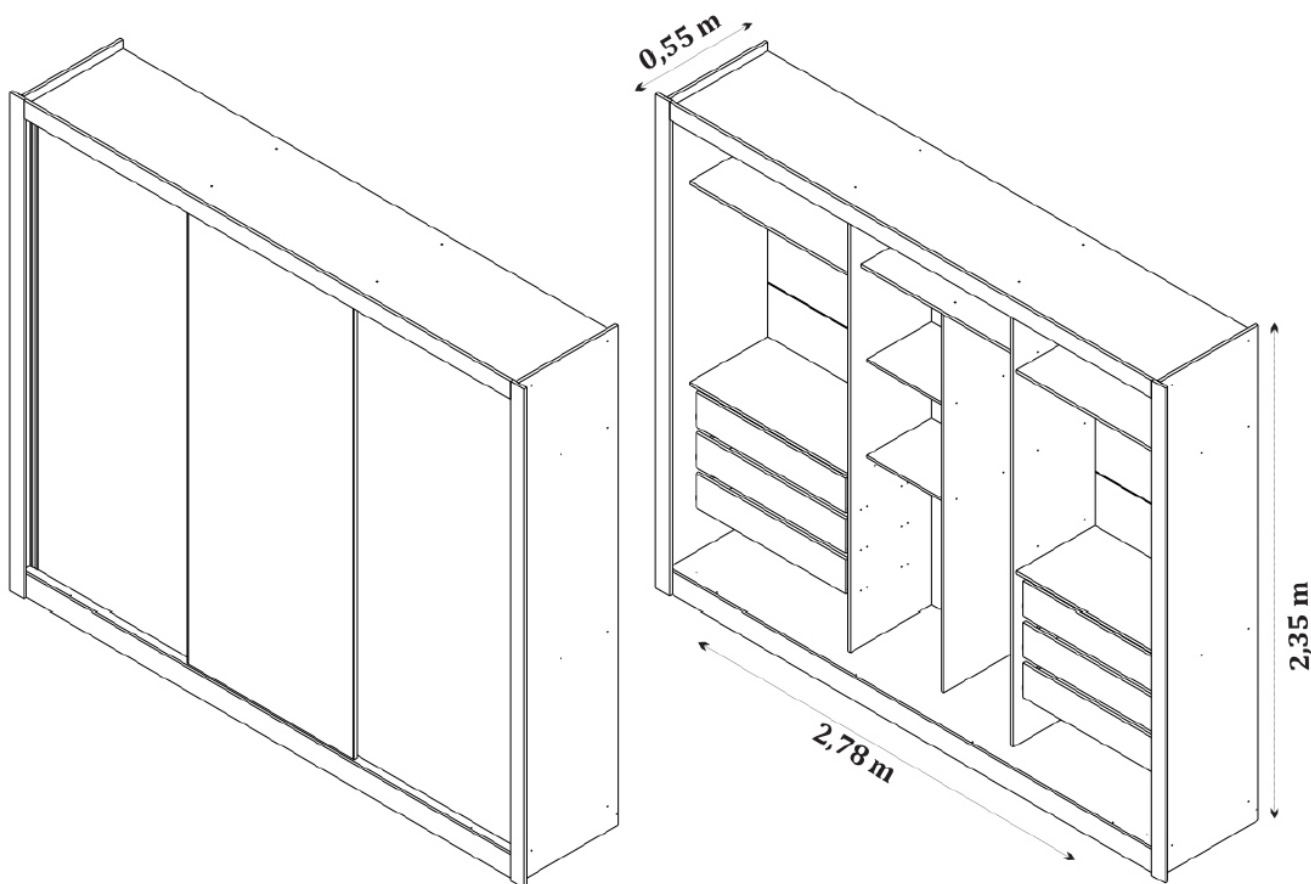

O fabricante se reserva ao direito de introduzir modificações técnicas em seus produtos, sem aviso prévio e sempre que julgar conveniente.

NECESSÁRIO:



IMPORTANTE: Antes da montagem deste produto, confira todo conteúdo de peças e componentes conforme indicado abaixo. No caso de falta de peças, entre imediatamente em contato com a loja onde o mesmo foi comprado para resolução do problema. A não observância desta instrução, exime o fabricante de quaisquer responsabilidades futuras.

LISTAGEM DE PEÇAS - ROUPEIRO 3 PORTAS PHOENIX/TORONTO

MEDIDAS EM mm

CÓDIGO DA PEÇA	QUANT.	DESCRIÇÃO	COMPRIMENTO	LARGURA	PROFUNDIDADE	TIPO DE MATERIAL
6632	1	BASE ROUP. PHOENIX	2670	540	12	MDF 12MM
5232	4	COSTA ROUP. PHOENIX	2696	544	2,5	MDF 2,5MM
5235	1	DIVISÃO CENT. ROUP. PHOENIX	1792	380	15	MDF 15MM
5239	2	DIVISÃO GDE. ROUP. PHOENIX	2165	445	15	MDF 15MM
5255	6	FRENTE GAV. ROUP. PHOENIX	820	163	15	MDF 15MM
5260	6	FUNDO GAV. ROUP. PHOENIX	784	350	2,5	MDF 2,5MM
5270	1	LATERAL DIR. ROUP. PHOENIX	2342	540	15	MDF 15MM
5285	1	LATERAL ESQ. ROUP. PHOENIX	2342	540	15	MDF 15MM
5288	2	PRATELEIRA CENT. ROUP. PHOENIX	433	355	12	MDF 12MM
5290	12	LATERAL GAVETA	350	110	12	MDF 12MM
5294	1	PRATELEIRA DIV. ROUP. PHOENIX	880	385	15	MDF 15MM
5296	2	COLUNA LAT. ROUP. PHOENIX	2342	75	15	MDF 15MM
5311	1	MOLDURA SUP. ROUP. PHOENIX	2640	85	15	MDF 15MM
5334	3	PORTA CENT. ROUP. PHOENIX	2136	900	15	MDF 15MM
5337	2	PRATELEIRA GAV. ROUP. PHOENIX	880	430	15	MDF 15MM
5345	2	PRATELEIRA MALEIRO ROUP. PHOENIX	880	430	15	MDF 15MM
5376	1	RODAPÉ FRONT. ROUP. PHOENIX	2670	110	15	MDF 15MM
5394	1	RODAPÉ TRAS. ROUP. PHOENIX	2670	110	15	MDF 15MM
6631	1	TAMP. ROUP. PHOENIX	2670	540	12	MDF 12MM
5452	6	TRASEIRO GAV. ROUP. PHOENIX	772	95	12	MDF 12MM
5455	2	TRAVESSA ROUP. PHOENIX	510	110	15	MDF 15MM

LISTAGEM DE FERRAGENS

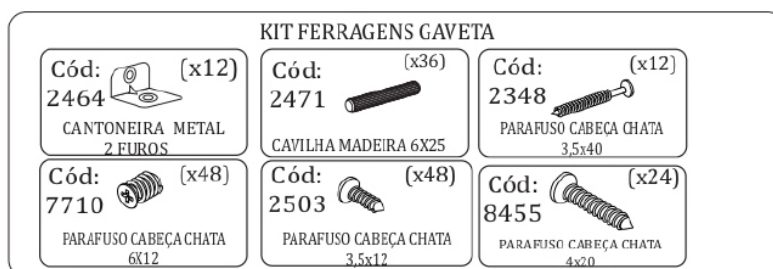
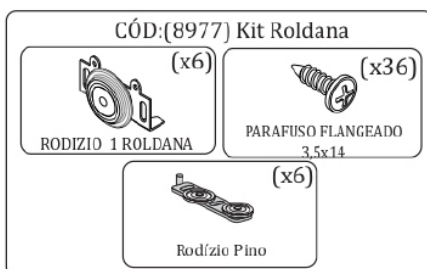
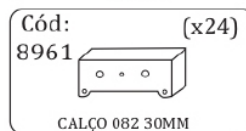
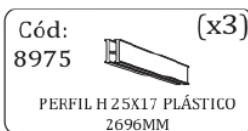
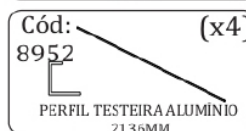
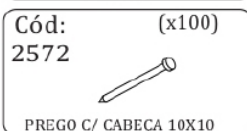
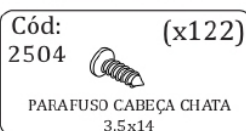

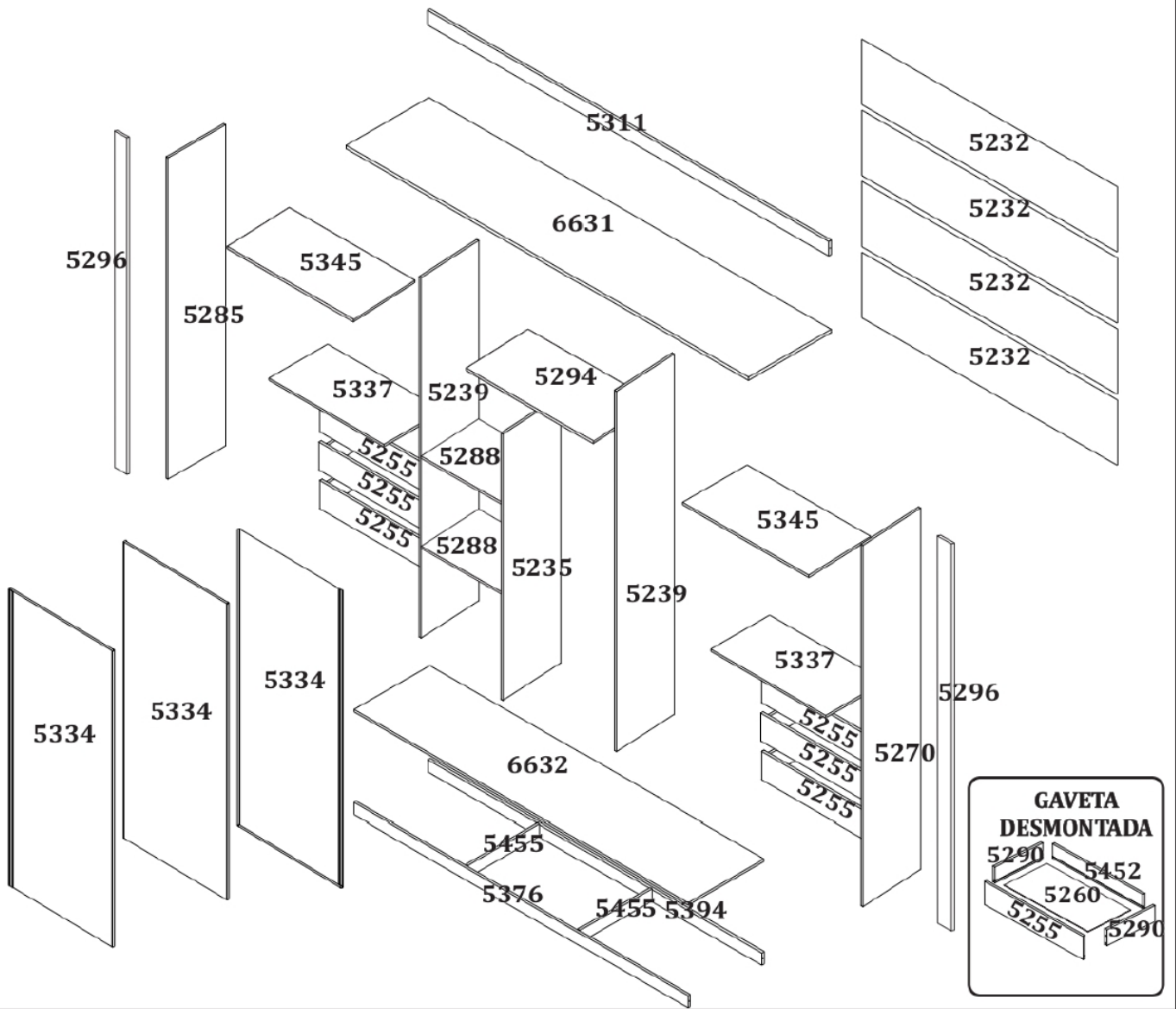

- 1** Fixe as travessas (5455) nos rodapés (5376/5394) com a cantoneira (2466) utilizando o parafuso (2504).

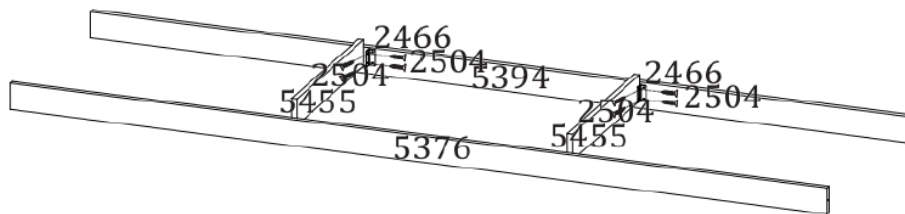

- 2** Utilize o Parafuso (2505) para fixar a Base (6632) nos Rodapés (5376/5394).

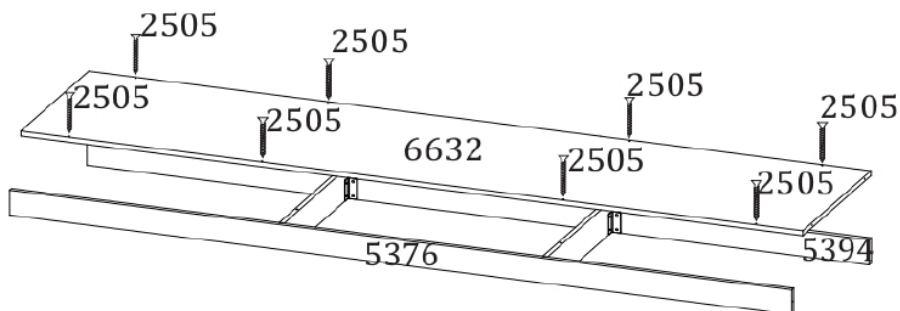

- 3** Fixe as sapatas (4617) nos rodapés (5376/5394), laterais (5270/5285) e travessas (5455) com o parafuso (2504). Fixe com o parafuso (2525) a lateral (5270) na base (6632) e nos rodapés. Em seguida, encaixe as cavilhas (2473) na divisão (5239) e fixe-as na base (6632).

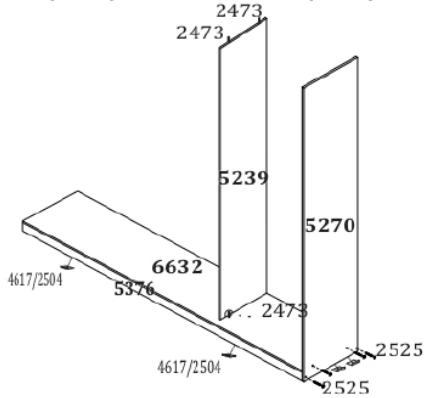

- 4** Fixe com o parafuso (2525) as prateleiras (5345 /5337) na lateral (5270) e divisão (5239).

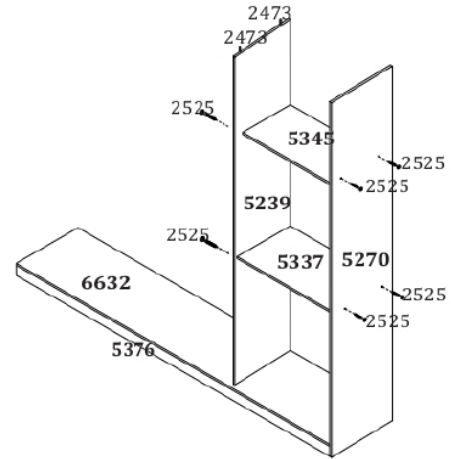

- 5** Fixe as cavilhas (2473) na divisão (5235) e depois encaixe-as na base (6632). Em seguida, fixe com o parafuso (2525) a prateleira (5294) na divisão (5239).

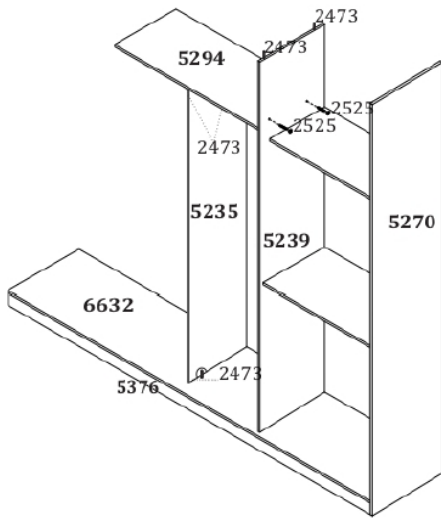

- 6** Fixe as cavilhas (2473) na divisão (5239) e depois encaixe-as na base (6632). Em seguida, fixe com o parafuso (2525) a prateleira (5294) na divisão (5239). Fixe a lateral (5285) na base e rodapés (5376/5394) com o parafuso (2525).

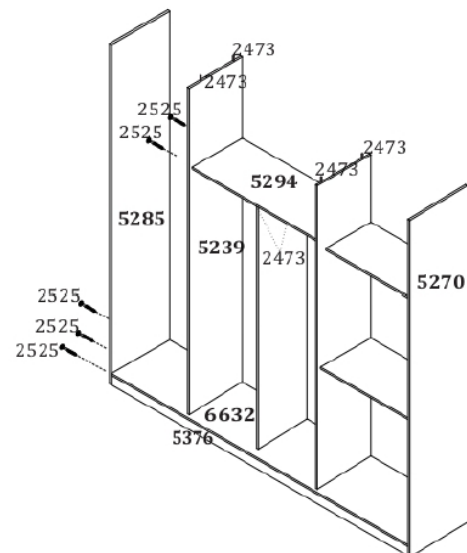

- 7** Fixe com o parafuso (2525) as prateleiras (5345/5337/5288) nas divisões (5235/5239) e na lateral (5285).

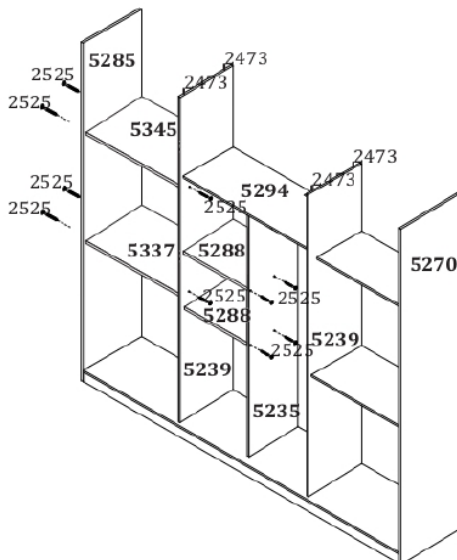

- 8** Fixe as cantoneiras (4619) na moldura (5311) e na coluna lateral (5296) utilizando o parafuso (9292). Em seguida, fixe a moldura (5311) no tampo (6631) e a coluna (5296) nas laterais (5270/5285).

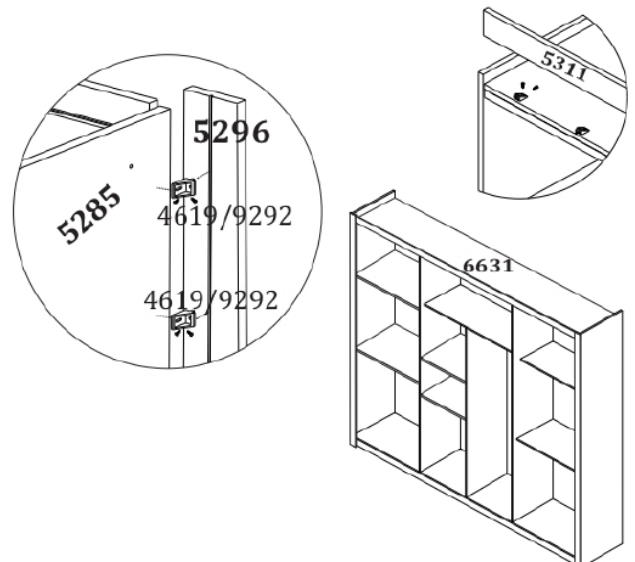

- 9** Fixe com os pregos (2572) as costas (5232), encaixando os perfis (8975).

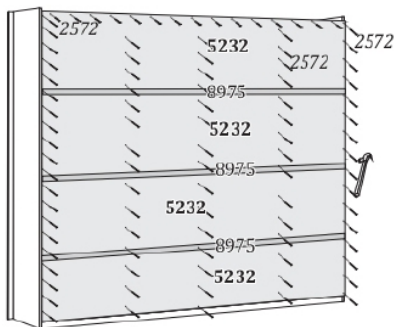

- 10** Monte as gavetas de acordo com as instruções abaixo.
Obs: Os trilhos da corredeira devem ser colocados faceando com a parte inferior das laterais de gaveta.

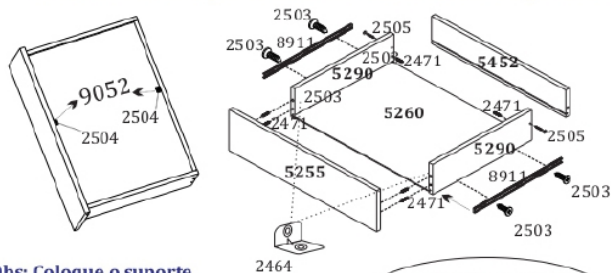

Obs: Coloque o suporte triangular (9052) no fundo de gaveta, para aumentar sua sustentabilidade utilizando o parafuso (2504).

Fixar frente de gaveta e a lateral com a Cantoneira (2464).

- 11** Fixe os calços de gaveta (8961) com o parafuso (7710) nas laterais (5270/5285), e nas divisões (5239). Em seguida, fixe com o parafuso (8455) as corredeiras (8911) nos calços. Fixe o trilho superior (8956) e inferior (8955) utilizando o parafuso (2504).

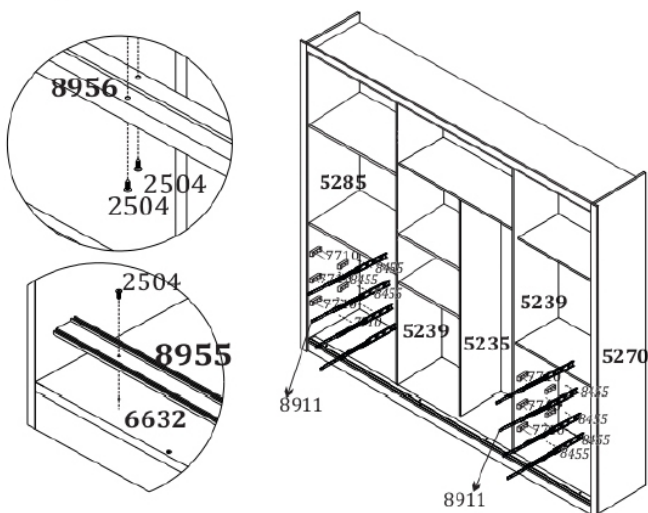

- 12** Fixe os suportes de cabideiro (2576) com o parafuso (2504)

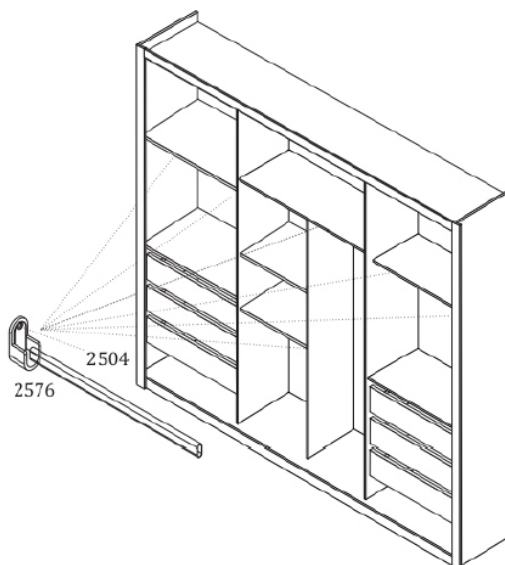

- 13** Siga as instruções abaixo para montagem das portas.

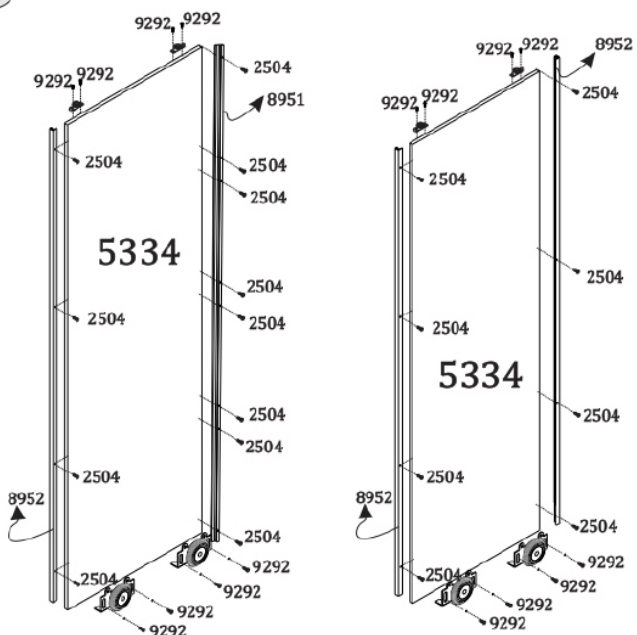

- 14** Encaixe as portas nos trilhos. Seu ROUPEIRO 3 PORTAS PHOENIX/TORONTO está montado para uso.

