

MANUAL DE MONTAGEM - ROUPEIRO 3 PORTAS OREGON/TUCSON

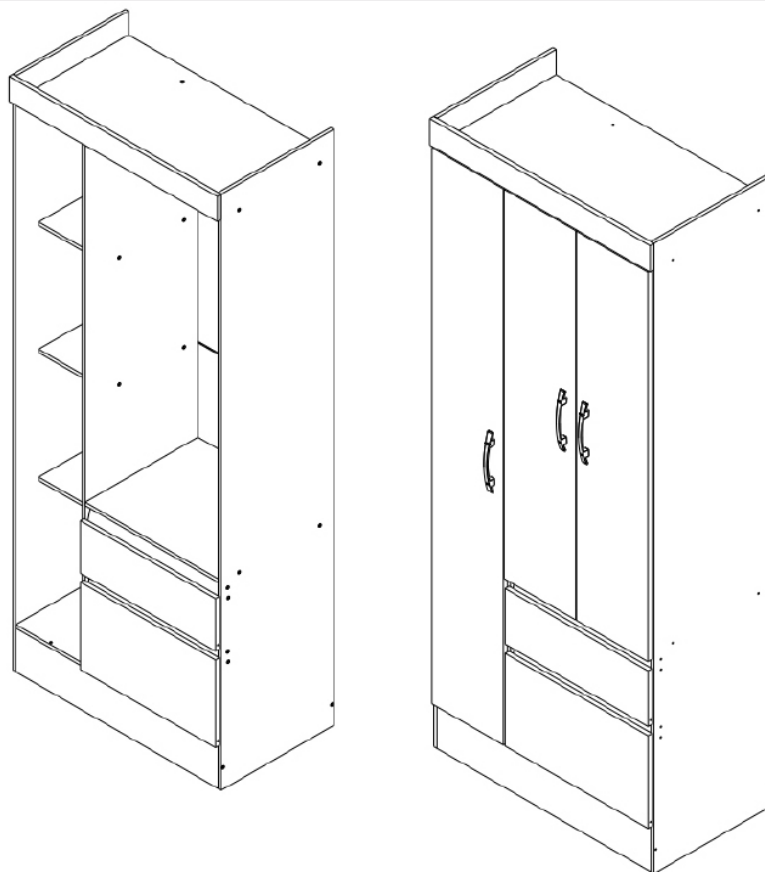

O fabricante se reserva ao direito de introduzir modificações técnicas em seus produtos, sem aviso prévio e sempre que julgar conveniente.

NECESSÁRIO:













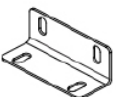



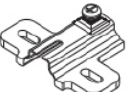





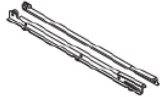

IMPORTANTE: Antes da montagem deste produto, confira todo conteúdo de peças e componentes conforme indicado abaixo. No caso de falta de peças, entre imediatamente em contato com a loja onde o mesmo foi comprado para resolução do problema. A não observância desta instrução, exime o fabricante de quaisquer responsabilidades futuras.

LISTAGEM DE PEÇAS - ROUPEIRO3 PORTAS OREGON/TUCSON

MEDIDAS EM (mm)

CÓDIGO DA PEÇA	QUANT.	DESCRIÇÃO	COMPRIMENTO	LARGURA	PROFUNDIDADE	TIPO DE MATERIAL
12991	1	LATERAL ESQUERDA	2040	445	12	MDP 12 MM
12992	1	LATERAL DIREITA	2040	445	12	MDP 12 MM
12993	1	DIVISÃO	1796	445	12	MDP 12 MM
12994	1	BASE	445	262	12	MDP 12 MM
12995	1	TAMPO	799	445	12	MDP 12 MM
12996	1	PRATELEIRA GAVETA	525	445	12	MDP 12 MM
12997	3	PRATELEIRA LATERAL	355	262	12	MDP 12 MM
12998	1	PORTA LATERAL	1798	267	15	MDP 15 MM
12999	2	PORTA CENTRAL	1260	267	15	MDP 15 MM
13000	1	FRENTE GAVETA MAIOR	534	300	15	MDP 15 MM
13001	1	FRENTE GAVETA	534	180	15	MDP15 MM
12990	2	LATERAL GAVETA	350	110	12	MDP 12 MM
13002	2	LATERAL GAVETA MAIOR	350	160	12	MDP 12 MM
13029	1	TRASEIRO GAVETA MAIOR	476	160	12	MDP 12 MM
13004	1	TRASEIRO GAVETA	476	90	12	MDP 12 MM
13005	2	FUNDO GAVETA	488	350	2,5	MDF 2,5 MM
13006	4	COSTA	818	452	2,5	MDF 2,5 MM
13007	2	DIVISÓRIA GAVETA	525	70	15	MDP 15 MM
13020	2	DIVISÓRIA GAVETA	525	70	15	MDP 15 MM
13008	1	MOLDURA	823	86	15	MDP 15 MM
13009	1	RODAPÉ FRONTAL	799	150	15	MDP 15 MM
13010	1	RODAPÉ TRASEIRO	799	150	15	MDP 15 MM

LISTAGEM DE FERRAGENS

<p>Cód: 2466 (x3)</p>  <p>CANTONEIRA METAL 4 FUROS</p>	<p>Cód: 2471 (x12)</p>  <p>CAVILHA MADEIRA 6X25</p>	<p>Cód: 13018 (x3)</p>  <p>PERFIL H 25X17 PLÁSTICO 818MM</p>	<p>Cód: 2677 (x1)</p>  <p>GIZ CERA</p>
<p>Cód: 2457 (x9)</p>  <p>CALÇO DOBRADIÇA 26MM Nº5</p>	<p>Cód: 2481 (x9)</p>  <p>DOBRADIÇA CURVA 26 MM</p>	<p>Cód: 13016 (x1)</p>  <p>CABIDEIRO ALUMÍNIO 515MM</p>	<p>Cód: 2505 (x8)</p>  <p>PARAFUSO CABEÇA CHATA 3,5x40</p>
<p>Cód: 2520 (x6)</p>  <p>PARAFUSO FLANGEADO 3,5X25</p>	<p>Cód: 2503 (x80)</p>  <p>PARAFUSO CABEÇA CHATA 3,5x12</p>	<p>Cód: 2525 (x36)</p>  <p>PARAFUSO FLANGEADO 4x40</p>	<p>Cód: 4617 (x6)</p>  <p>SAPATA L 1 FURO</p>
<p>Cód: 2576 (x2)</p>  <p>SUPORE CABIDEIRO 30X16</p>	<p>Cód: 7239 (x70)</p>  <p>PREGO C / CABEÇA 8X8</p>	<p>Cód: 2464 (x4)</p>  <p>CANTONEIRA METAL 2 FUROS</p>	<p>Cód: 8864 (x2)</p>  <p>CORREDIÇA METAL 350MM</p>
<p>Cód: 11841 (x3)</p>  <p>PUXADOR ARCHI</p>	<p>Cód: 2513 (x8)</p>  <p>PARAFUSO CABEÇA CHATA 6X8</p>	<p>VOLUME DE PÉ CÓD.13039 (Opcional)</p>	
<p>Cód: 2504 (x16)</p>  <p>PARAFUSO CABEÇA CHATA 3,5x14</p>	<p>Cód: 2558 (x4)</p>  <p>PARAFUSO SOBERBO 7X50</p>	<p>Cód: 2466 (x4)</p>  <p>CANTONEIRA METAL 4 FUROS</p>	<p>Cód: 13045 (x2)</p>  <p>TRAVESSA PÉ 415 x 50 x 15</p>
	<p>Cód: 13046 (x4)</p>  <p>PÉ DE PLÁSTICO</p>		

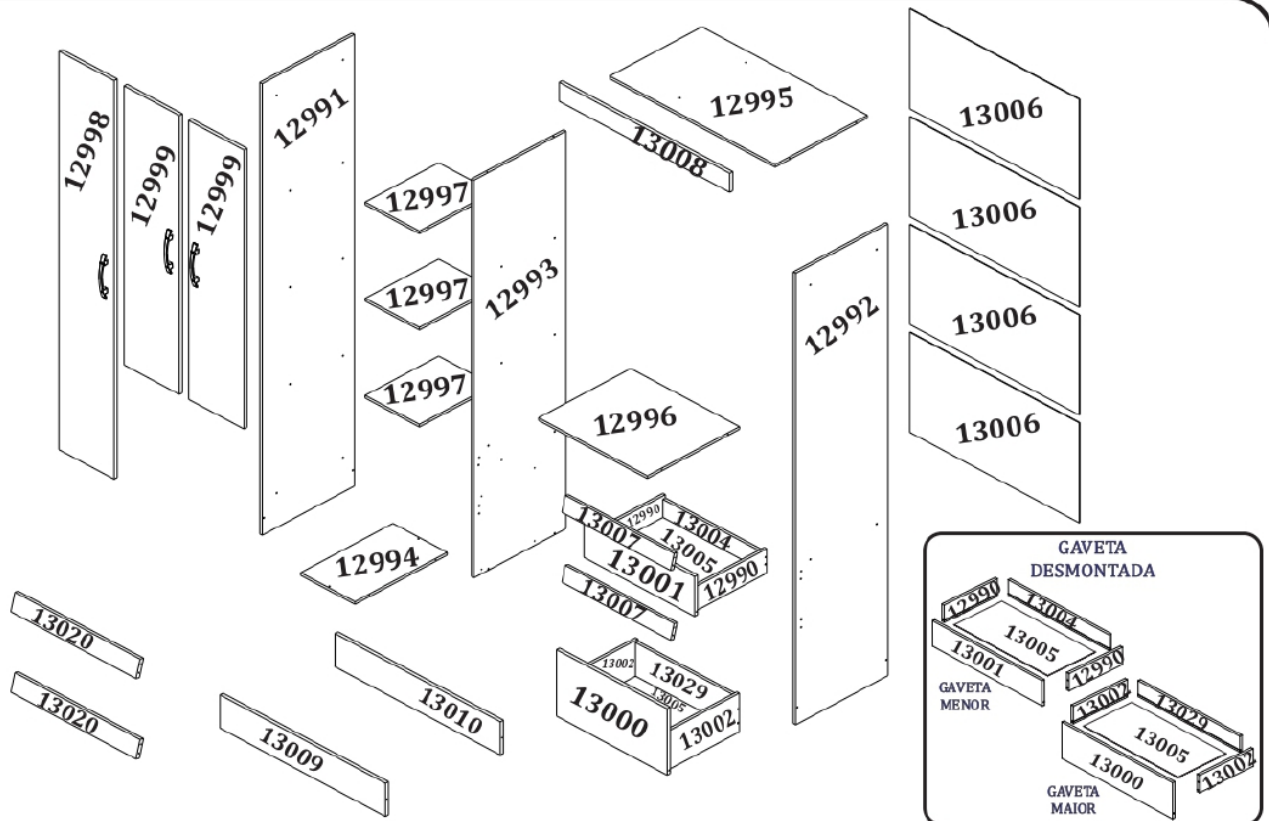

- 1** Fixe a lateral (12991) nos rodapés (13009/13010) utilizando o parafuso (2525).

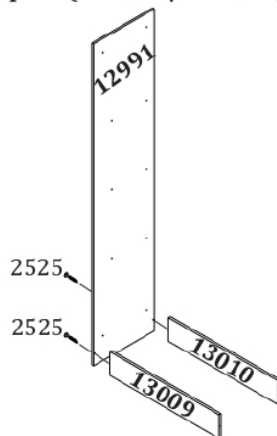

- 2** Na montagem do roupeiro com os pés, monte como demonstram os desenhos abaixo: Fixe os pés (13046) na travessa (13045) com o parafuso (2558). Em seguida, fixe as cantoneiras (2466) na travessa (13045) com o parafuso (2504). Fixe os pés já montados nos rodapés utilizando a cantoneira (2466) e o parafuso (2504). Fixe a lateral (12991) nos rodapés (13009/13010) utilizando o parafuso (2525).

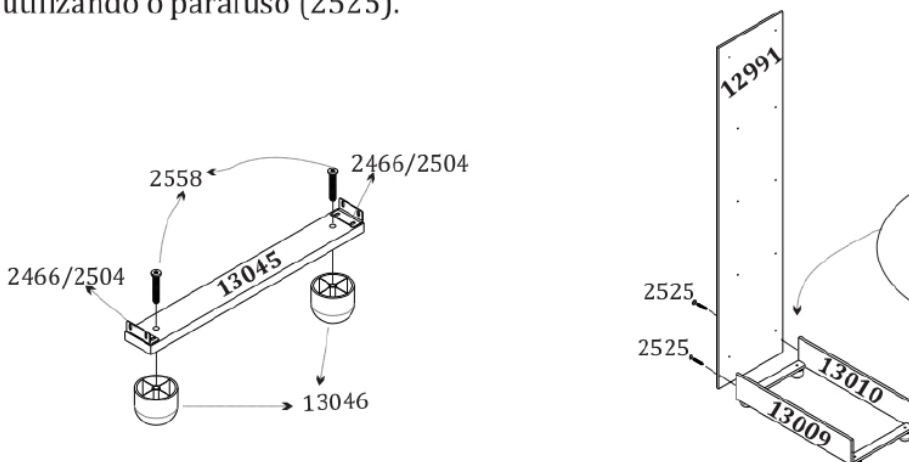

- 3** Fixe a lateral (12992) nos rodapés (13009/13010), utilizando o parafuso (2525).

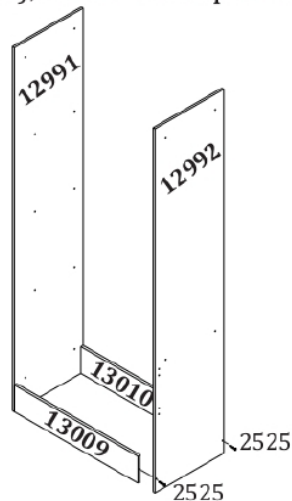

- 4** Fixe a base (12994) na lateral (12991) com o parafuso (2525) e em seguida, fixe nos rodapés com o parafuso (2505).

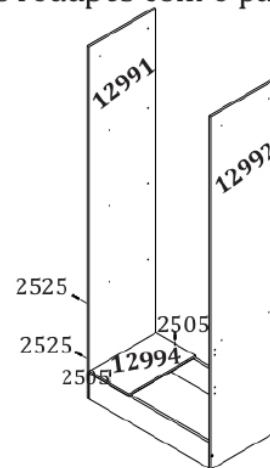

- 5** Fixe a divisão (12993) na base (12994), utilizando o parafuso (2505).

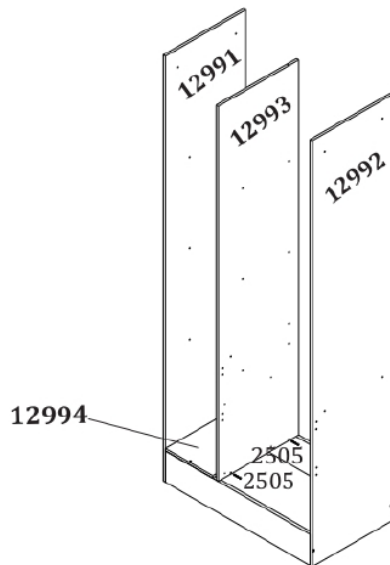

- 6** Fixe a prateleira gaveta (12996) na lateral (12992) e na divisão (12993), utilizando o parafuso (2525).

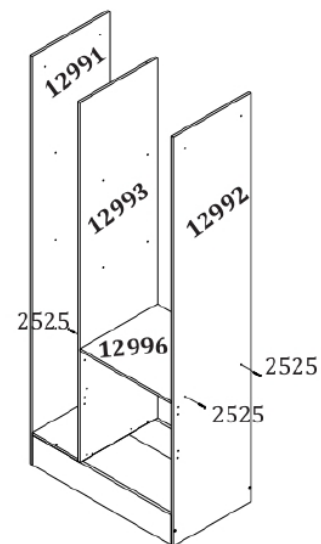

- 7** Fixe a prateleira lateral (12997) na lateral (12991) e na divisão (12993), utilizando o parafuso (2525).

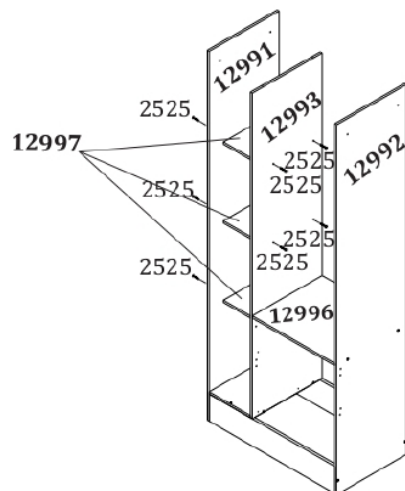

- 8** Fixe o tampo (12995) na divisão (12993) e nas laterais (12991/12992), utilizando o parafuso (2525).

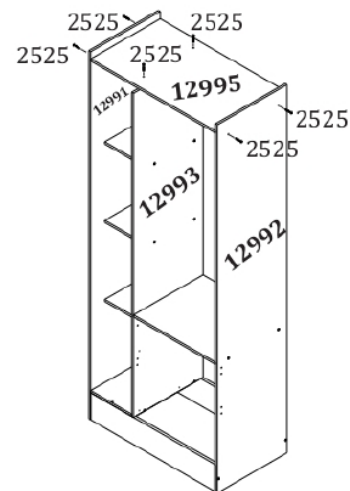

- 9** Fixe com prego (7239) as costas (13006), encaixando os perfis (13018).

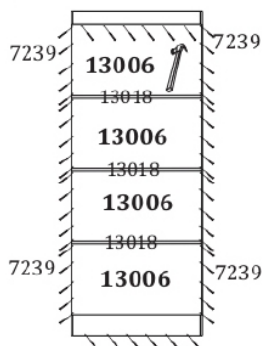

- 10** Fixe a moldura (13008) no tampo (12995), utilizando a cantoneira (2466) e o parafuso (2503).

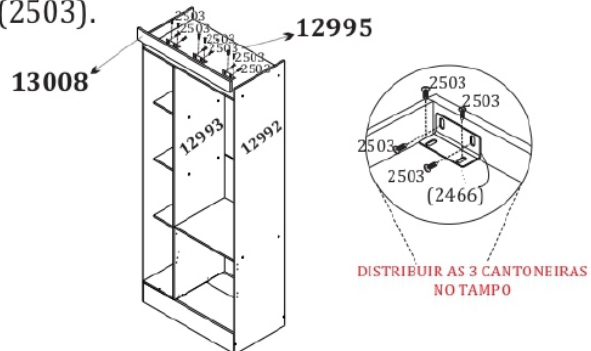

- 11** Fixe a corrediça (8864) na divisão (12993) e na lateral (12992) com o parafuso (2513). Fixe a divisória de gaveta (13007) ou (13020) na divisão (12993) e na lateral (12992) com o parafuso (2525).

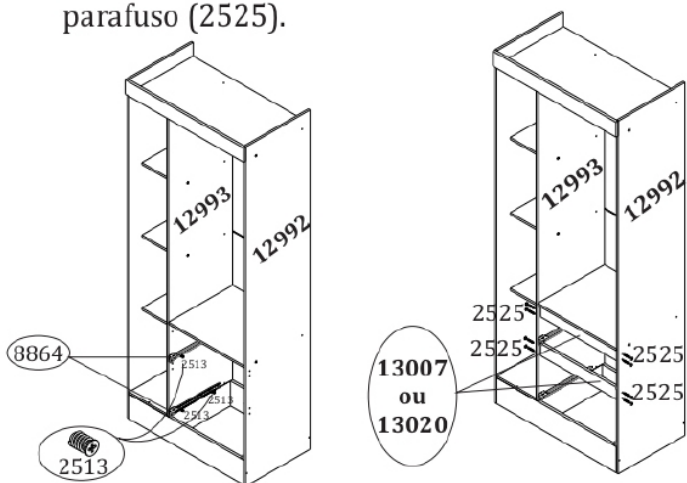

- 12** Monte as gavetas de acordo com a figura abaixo e fixe no roupeiro. Em seguida, fixe o suporte cabideiro (2576) com o parafuso (2503) na divisão e na lateral.

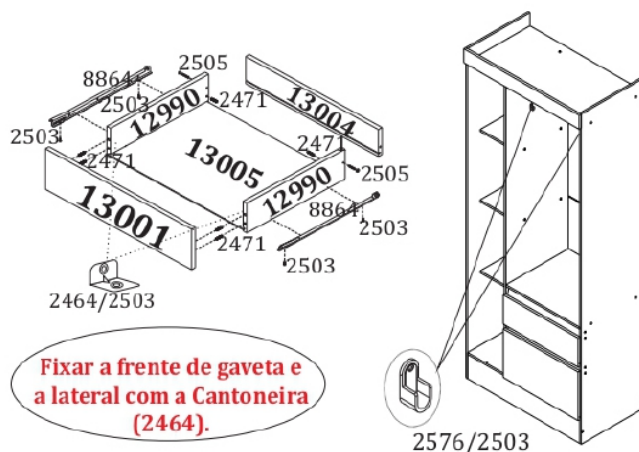

- 13** Monte as portas (12998/12999) de acordo com o desenho abaixo.

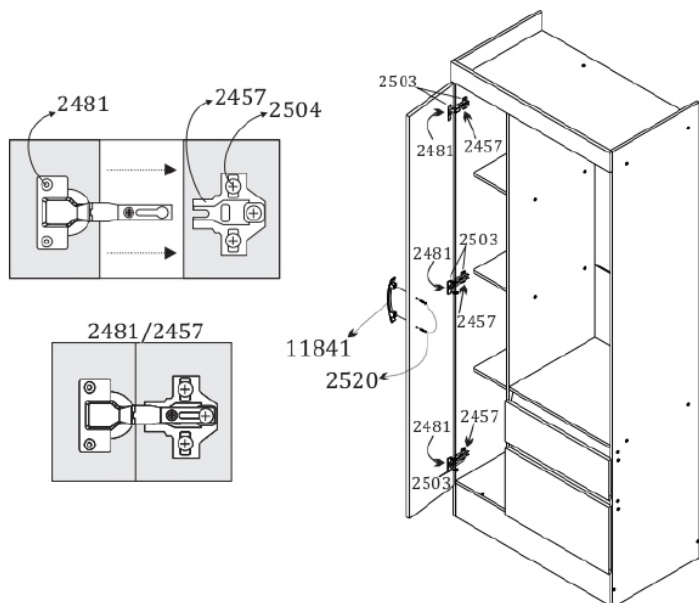

- 14** Seu ROUPEIRO 3 PORTAS OREGON/TUCSON está montado para o uso.

