

Item	Caixa Caja Box	Qtd Ctd Qty	Descrição Descripción Description	Medidas (mm)   Dimensions (mm)   Size (measurements) (mm)
01	2/7	01	Base   Base   Base	2589x481x15
02	1/7	02	Travessa lateral base   Carril lateral base   Base side crossbar	470x90x15
03	4/7	03	Travessa central base   Carril central base   Central base rail	451x70x15
04	2/7	01	Travessa frontal base   Carril delantera de la base   Base front crossbar	2619x90x25
05	1/7	01	Lateral esquerda   Lateral izquierda   Left side	2295x500x15
06	1/7	01	Divisão Gaveta Esquerda   División Cajón Izquierdo   Left Drawer Split	800x448x15
07	1/7	01	Divisão Esquerda Nicho   División Izquierda Niche   Left Division Niche	1021x355x15
08=14	4/7	01	Tampo das Gavetas   Tapa de los cajones   Drawer Top	651x450x15
09=19	4/7	02	Prateleira   Estante   Shelf	636x450x15
10	3/7	01	Divisão   División   Division	1836x450x15
11=15	4/7	01	Prateleira Menor   Estante Menor   Small Shelf	636x350x15
12	3/7	01	Divisão Gaveta Direita   División Cajón Derecha   Right division Drawer	800x448x15
13	1/7	01	Divisão Direita Nicho   División Derecha Niche   Niche Right Division	1021x355x15
14=08	4/7	01	Tampo das Gavetas   Tapa de los cajones   Drawer Top	651x450x15
15=11	5/7	01	Prateleira Menor   Estante Menor   Small Shelf	636x350x15
16	1/7	01	Ripa do Maleiro   Listón del Armario de Equipaje   Clapboard luggage locker	414x73x15
17	3/7	01	Chão do Maleiro   Piso del Armario de Equipaje   Floor of the Maleiro	2589x450x15
18	1/7	01	Lateral direita   Lateral derecha   Right side	2295x500x15
19=09	5/7	02	Prateleira   Estante   Shelf	636x450x15
20	2/7	01	Tampo   Tapa   Top	2589x481x15
21	3/7	01	Fundo Superior   Fondo Superior   Superior background	2600x435x6
22	5/7	04	Fundo   Fondo   Bottom	1858x649x6
23	2/7	02	Moldura Lateral   Marco lateral   Lateral Frame	2351x80x30
24	2/7	01	Moldura Superior   Marco superior   Upper Frame	2619x80x30
25	3/7	02	Painel Central   Panel central   Central Panel	1292x566x15
26	6/7	02	Painel Inferior Superior   Panel Inferior Superior   Top Bottom Panel	1292x566x15
27	6/7	02	Painel Central espelho   Panel central espejo   Mirror Central Panel	1292x566x15
28	6/7	02	Painel Inferior Superior Espelho   Panel Inferior Superior Espejo   Bottom Top Panel Mirror	1292x566x15
29	7/7	04	Espelho com furo   Espejo con orificio   Mirror with hole	1250x540x3
30	1/7	02	Frete de gaveta   Frente de cajón   Front of drawer	628x106x15
31	4/7	04	Lado de Gaveta Estreito   Lado de Gaveta Estrecho   Narrow Drawer Side	400x90x15
32=39	4/7	02	Fundo de gaveta recortado   Fondo del cajón recortado   Cropped drawer bottom	592x411x3
33	4/7	02	Ripa de trás estreita   Lath trasera estrecha   Narrow rear clamp	611x90x15
34	4/7	04	Divisória Maior   Divisoria Mayor   Greater Divisory	581x60x9
35	4/7	04	Divisória Menor   División Menor   Small Partition	400x90x9
36	1/7	04	Frete de Gaveta com Usinagem   Frente de Cajón con mecanizado   Drawer Front with Machining	628x200x15
37	4/7	04	Vidro incolor   Vidrio incoloro   Colorless glass	540x100x3
38	1/7 e 4/7	08	Lado de gaveta   Lado del cajón   Side of drawer	400x180x15
39=32	4/7	04	Fundo de gaveta recortado   Fondo del cajón recortado   Cropped drawer bottom	592x411x3
40	4/7	04	Ripa de trás   Malla detrás   Rear lath	611x180x15



Ind. e Com. de Móveis Henn  
Mondai - SC - Brasil  
+55 49 3674.3500  
@moveishenn  
www.henn.com.br

# INSTRUÇÕES DE MONTAGEM

INSTRUCCIONES DE MONTAJE  
ASSEMBLY INSTRUCTIONS

## Roupeiro Cavic 02 Portas Deslizantes | Ropero Cavic 02 Puertas Deslizantes | Wardrobe Cavic 02 Sliding Doors

c D209-23 Duna  
c D209-108 Duna/Off White

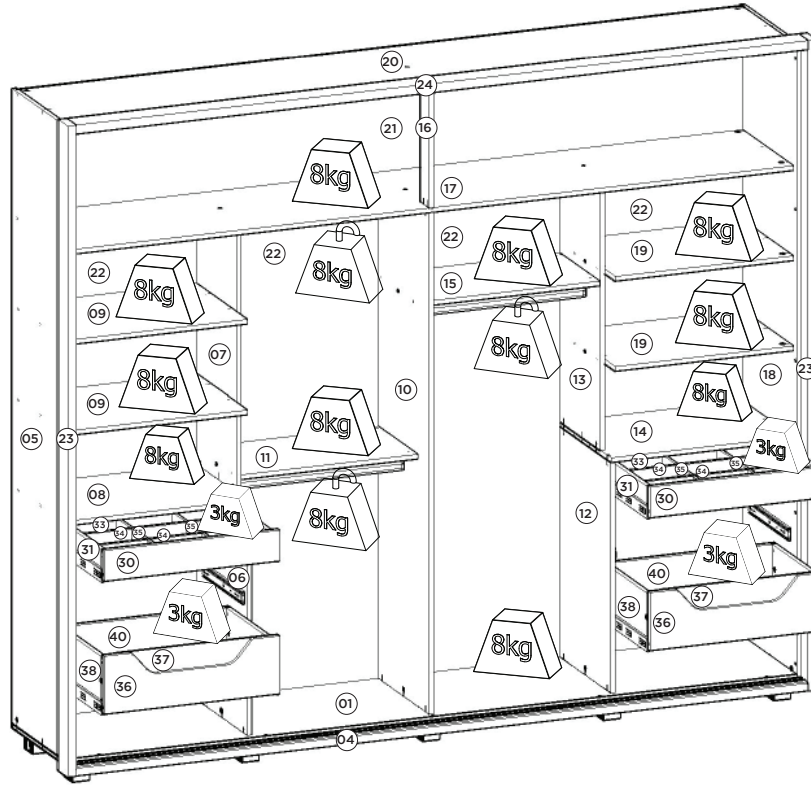
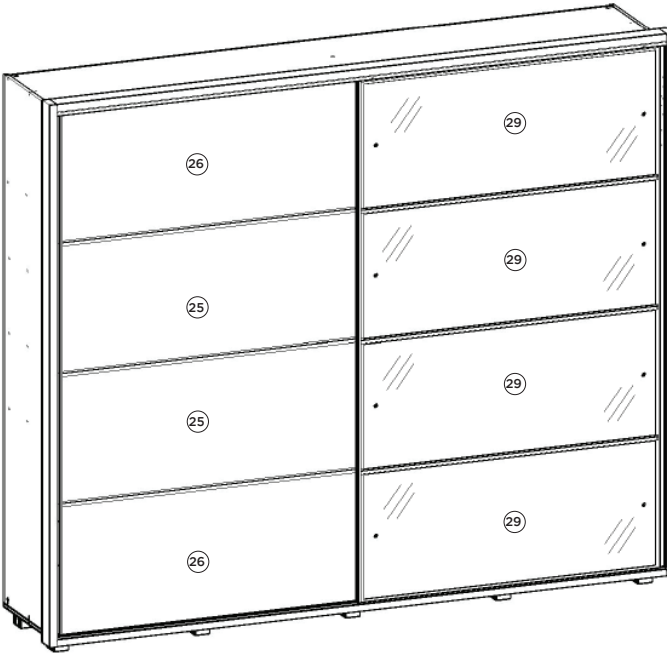

Pesos máximos recomendados com carga distribuída  
Peso máximo recomendado con la carga distribuida  
Recommended maximum weights with evenly distributed.

### Ferragens | Herrajes | Hardware

<b>A</b> 15x Parafuso 4,0x35mm CHT. Tornillo 4,0x35mm CHT. Screw 4,0x35mm CHT.	<b>B</b> 25x Parafuso 4,0x30mm FLA. Tornillo 4,0x30mm FLA. Screw 4,0x30mm FLA.	<b>C</b> 15x Parafuso 4,0x25mm CHT. Tornillo 4,0x25mm CHT. Screw 4,0x25mm CHT.	<b>D</b> 15x Parafuso 3,5x40mm CHT. Tornillo 3,5x40mm CHT. Screw 3,5x40mm CHT.	<b>E</b> 40x Parafuso 3,5x14mm FLA. Tornillo 3,5x14mm FLA. Screw 3,5x14mm FLA.	<b>F</b> 08x Parafuso 3,5x14mm FLA Cromado Tornillo 3,5x14mm FLA Cromado Screw 3,5x14mm FLA Chrome
<b>G</b> 132x Parafuso 3,5x12mm CHT. Tornillo 3,5x12mm CHT. Screw 3,5x12mm CHT.	<b>H</b> 04x Parafuso 3,0x30mm CHT. Tornillo 3,0x30mm CHT. Screw 3,0x30mm CHT.	<b>I</b> 183x Parafuso 3,0x20mm FLA. Tornillo 3,0x20mm FLA. Screw 3,0x20mm FLA.	<b>J</b> 58x Parafuso 3,0x16mm CHT. Tornillo 3,0x16mm CHT. Screw 3,0x16mm CHT.	<b>K</b> 108x Cavilha 8x25mm Cinta 8x25mm Dowel 8x25mm	<b>L</b> 06x Cantoneira plástica Cantoneira plástica Plastic angle brackets
<b>M</b> 46x Cantoneira suporte triangular Cantoneira soporte triangular Triangle support angle	<b>N</b> 08x Bucha Fixador de Espelho Buje de sujeción del espejo Mirror fixing bush	<b>O</b> 47x Parafuso minifix Tornillo minifix Minifix bolt	<b>P</b> 47x Tambor minifix Tambor minifix Minifix drum	<b>Q</b> 16x Suporte fixação de vidro Soporte de fijación de cristal Glass fixing bracket	<b>R</b> 18x Suporte metal Soporte metálico Metal support
<b>S</b> 06x Suporte cabideiro oblongo Zamac ZB Soporte de cabina oblongo Zamac ZB Zamac ZB oblong hanger bracket	<b>T</b> 03x Cabideiro Alum. 628mm Alu 628mm percha Alu coat hanger 628mm	<b>U</b> 01x Kit Roldana JM841R (2Portas) Kit Roldán JM841R (2 Puertas) Kit Roldana JM841R (2 Doors)	<b>V</b> 06x Corredeira telescópica Corredera telescópica Telescopic slide	<b>W</b> 01x Kit Amortecedor Kit de amortiguador Shock Absorber Kit	<b>X</b> 10x Sapata retangular 70x60mm Zapata rectangular 70x60mm Rectangular shoe 70x60mm
<b>Y</b> 02x Perfil Puxador MOV4072 - 2264mm Perfil Tirador MOV4072 - 2264mm Profile Handle MOV4072 - 2264mm	<b>Z</b> 02x Perfil Anti-empeno U 2264mm Perfil anti-empeno U 2264mm Anti-warp profile U 2264mm	<b>AA</b> 01x Trilho Superior 2617mm Carril superior 2617mm Top Rail 2617mm	<b>AB</b> 01x Trilho Inferior 2617mm Carril inferior 2617mm Lower Rail 2617mm	<b>AC</b> 03x Sachê de cola Bolsa de pegamento Glue bag	<b>AD</b> 02x Giz de correção Tiza de corrección Chalk of correction
<b>AE</b> 31x Adesivo tapa parafuso 17mm Adhesivo tapón de tornillo 17mm Bolt cover adhesive 17mm	<b>AF</b> 43x Adesivo tapa parafuso 10mm Adhesivo tapón de tornillo 10mm Bolt cover adhesive 10mm	<b>AG</b> 08x Batente PVC para Porta Parada de PVC para Puerta PVC Door Stop	<b>AH</b> 01x Etiqueta resinada Henn Etiqueta resinada Henn Henn resin label	<b>HENN</b>	

### Requisitos para montagem Requisitor para la montaje Assembly Requirements

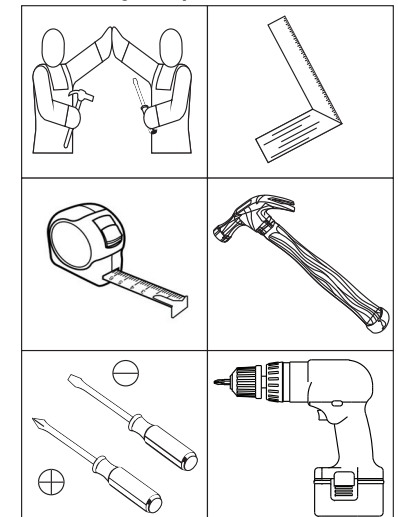

Imagens meramente ilustrativas  
Imágenes meramente ilustrativas  
Images for illustration only

**AVISO**  
Para limpeza de seu móvel, use uma flanela seca ou umedecida, e não utilize produtos químicos que possam danificar seu produto.

**SISTEMA DE MONTAGEM**  
O sistema de montagem dos produtos, funciona de acordo com a ordem crescente dos números indicados no desenho. Ex: 01, 02, 03, 04... até a conclusão da montagem.

**ADVERTENCIA**  
Para limpieza de su móvil, use una flanela seca o húmeda, y no utilice productos químicos que puedan dañar su producto.

**SISTEMA DE MONTAJE**  
El sistema de montaje de los productos funciona de acuerdo con el orden creciente de los números indicados en el dibujo. Ej.: 01, 02, 03, 04... hasta la conclusión del montaje.

**NOTICE**  
To clean your furniture, use a dry or wet cloth, and do not use chemicals that may damage your product.

**ASSEMBLY SYSTEM**  
The products' assembly system works according to the increasing order of the indicated numbers. For example: 01, 02, 03, 04 ... to the end of the assembly.

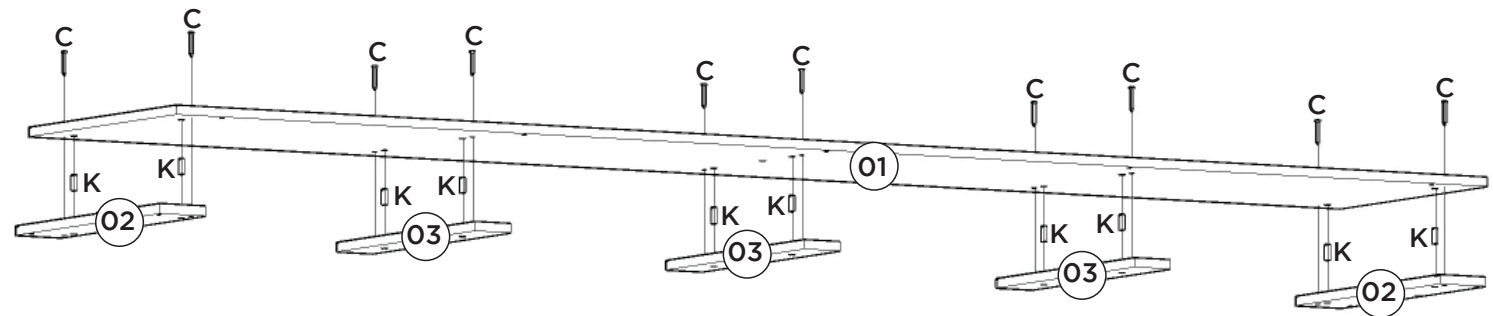

Para a colocação da travessa frontal base (04) alinhar a mesma com as travessas laterais base (02).

Para la colocación del travesaño delantero base (04) para alinearlo con las vigas de base lateral (02).

For placement of the base front strut (04) to align the same with the base side beams (02).

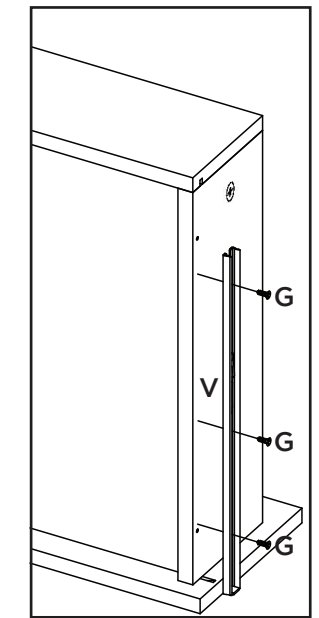
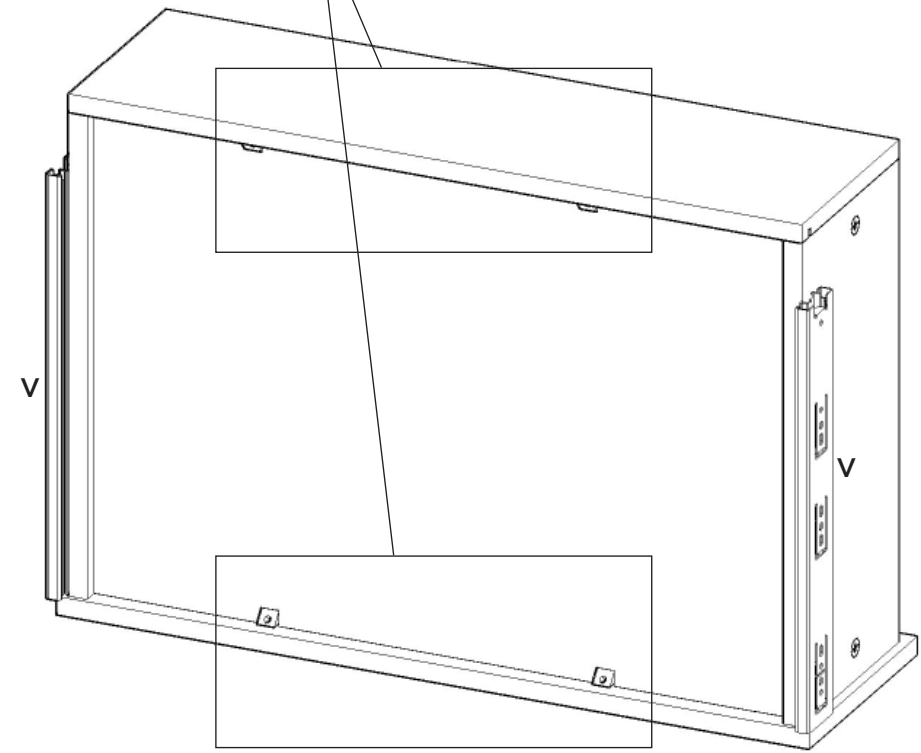
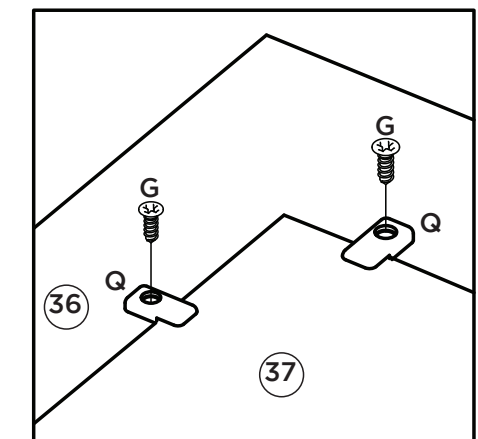
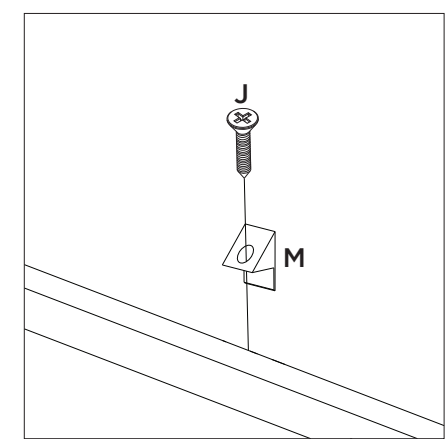
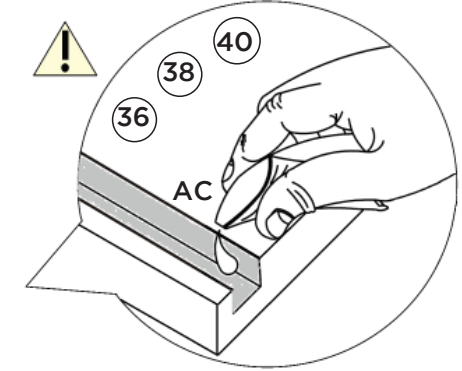
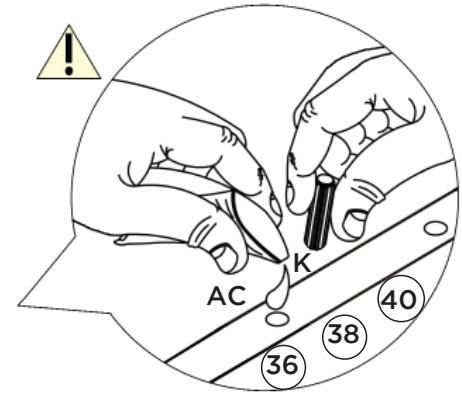
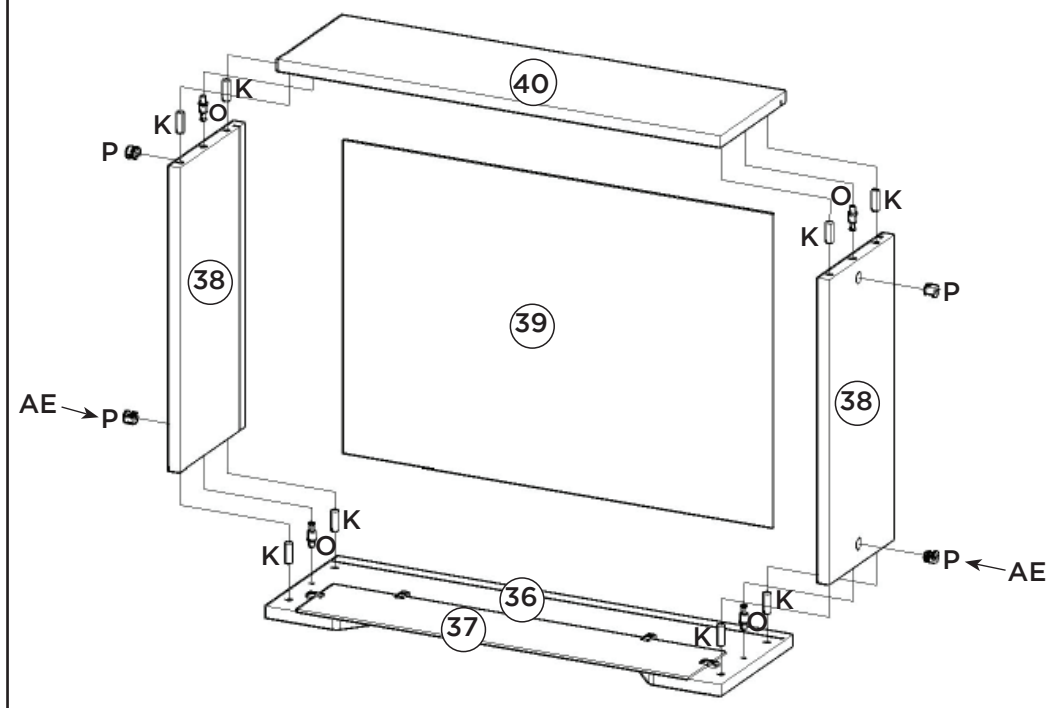
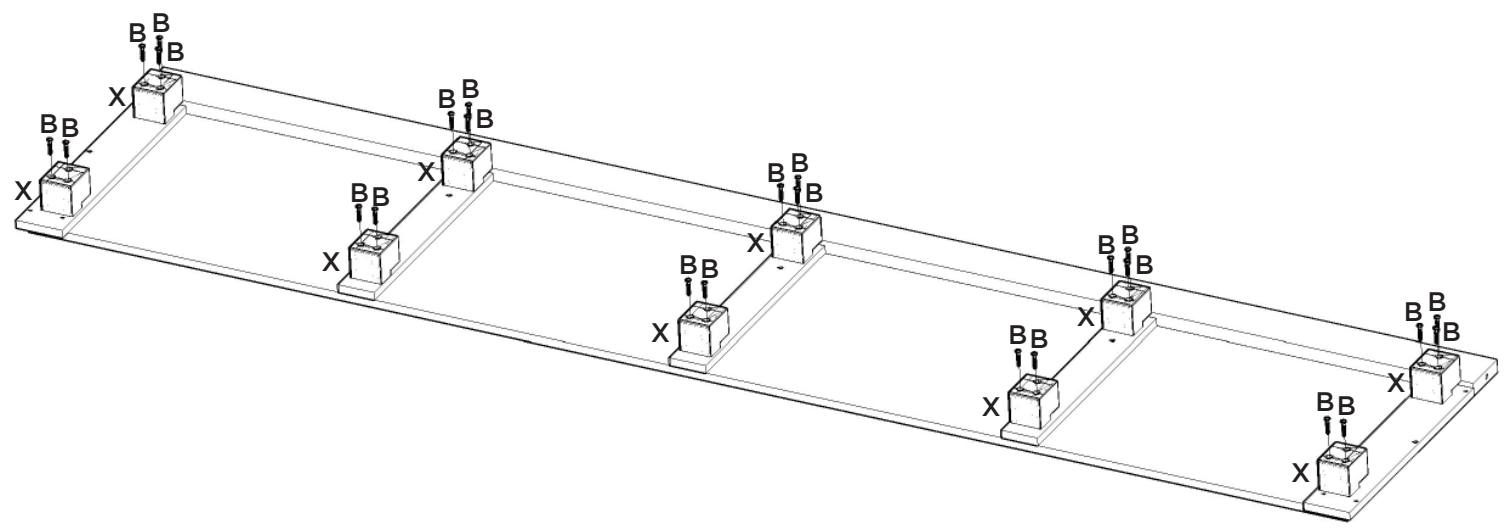
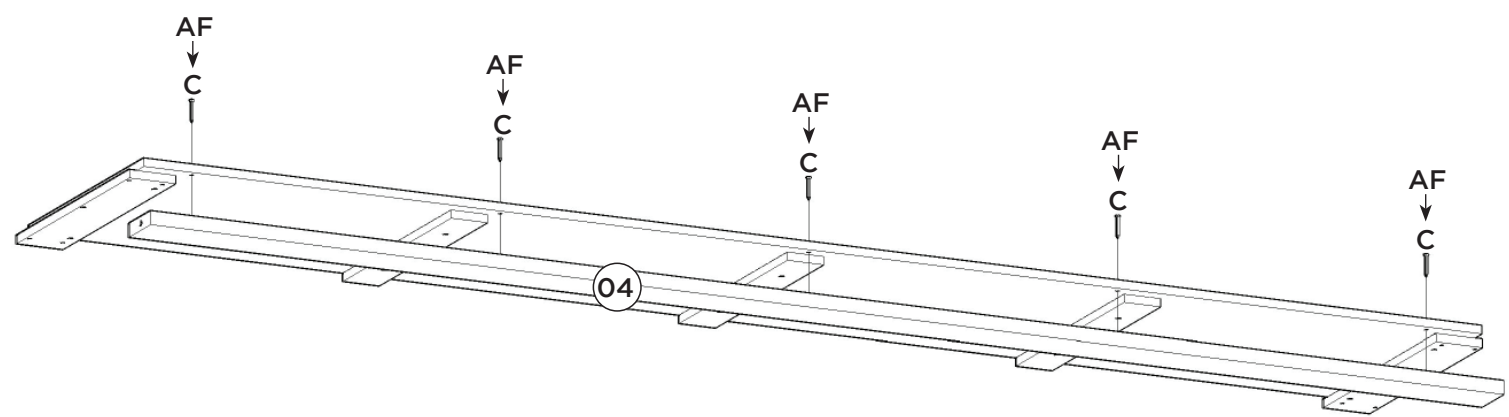

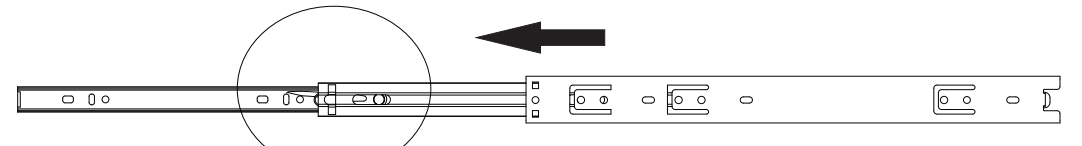

Para a desmontagem da corredeira siga a instrução ao lado.

Para el desmontaje seguimiento de diapositivas la instrucción siguiente a.

For the dismount of the sliding onem follows the instruction aside.

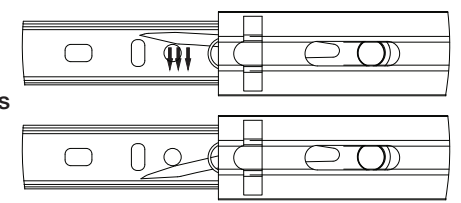

Fixar as corredeiras nessas furações  
Fijar las diapositivas de estos agujeros  
Fix slides in these drillings

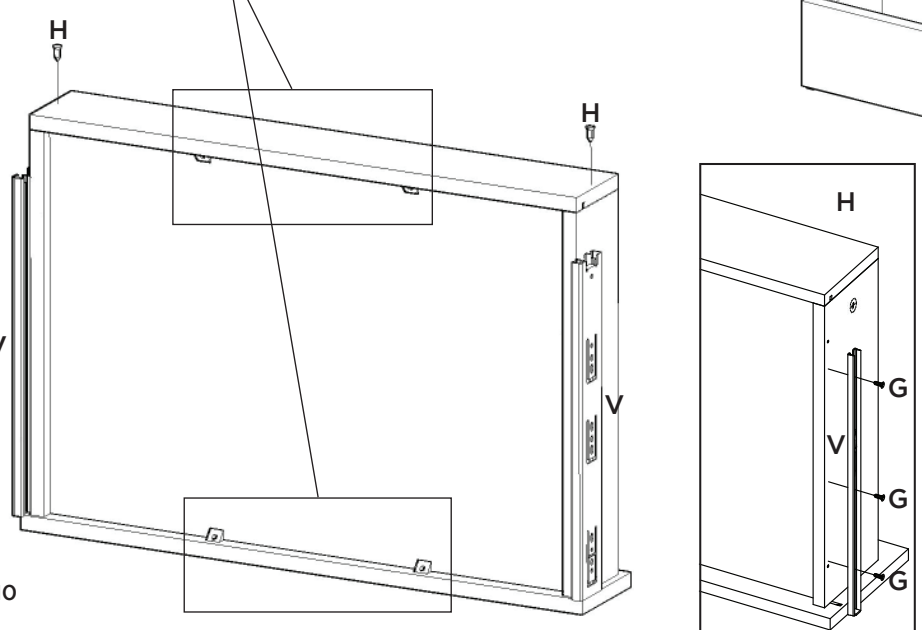
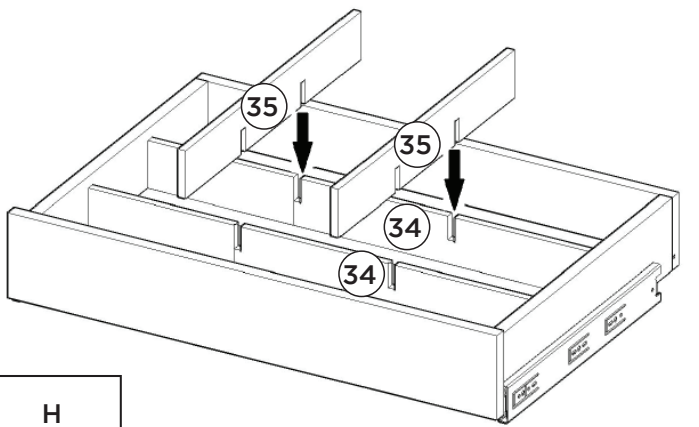
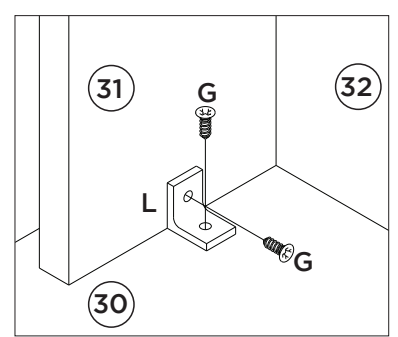
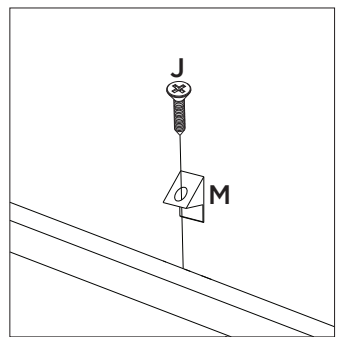
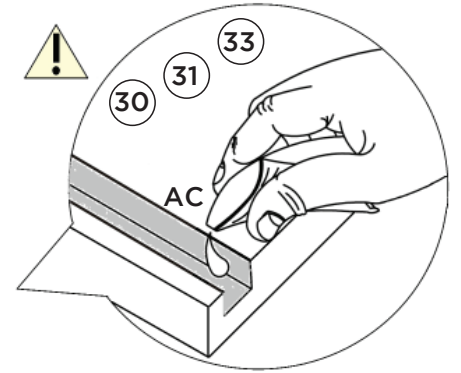
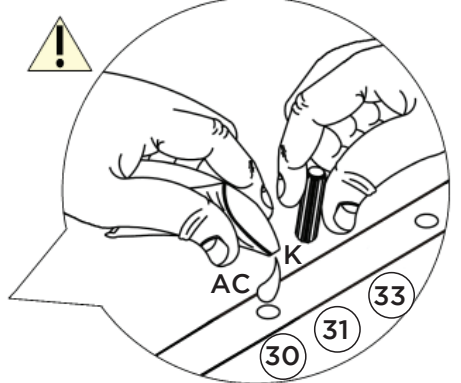
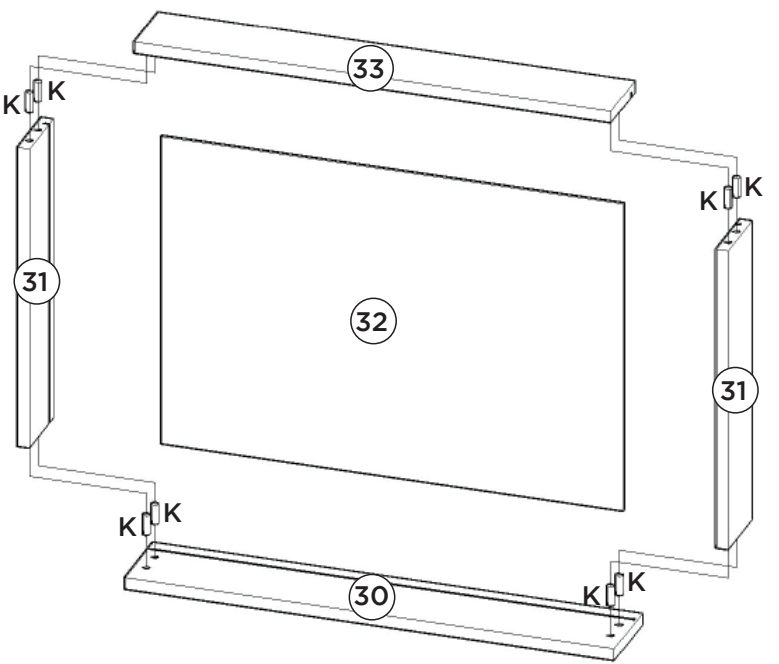

Recomenda-se montar estas peças separadamente, antes de fixar no móvel.

Se recomienda montar estas piezas por separado, antes de fijar en el mueble.

It is recommended to mount these parts separately before attaching to the cabinet.

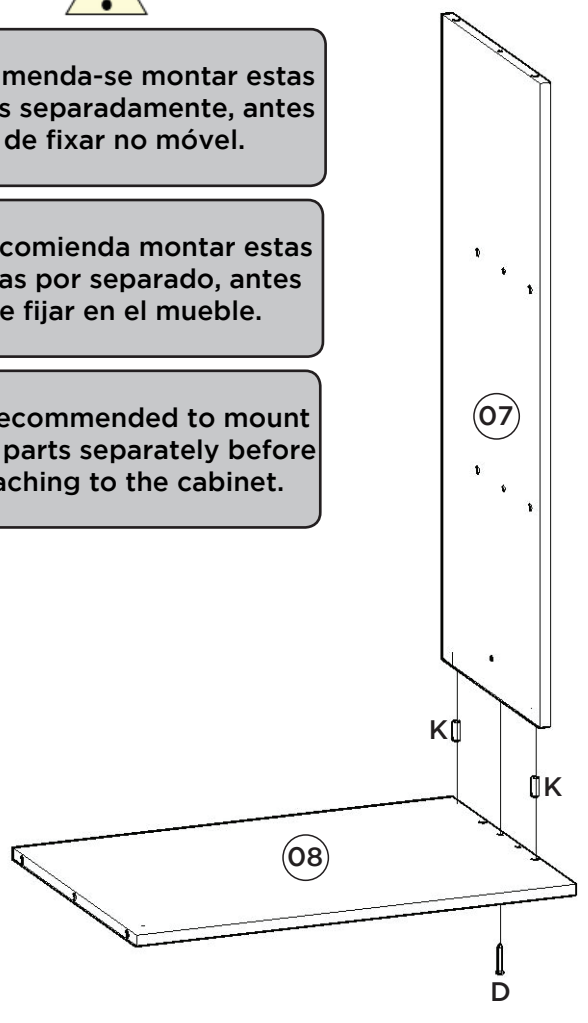

Recomenda-se montar estas peças separadamente, antes de fixar no móvel.

Se recomienda montar estas piezas por separado, antes de fijar en el mueble.

It is recommended to mount these parts separately before attaching to the cabinet.

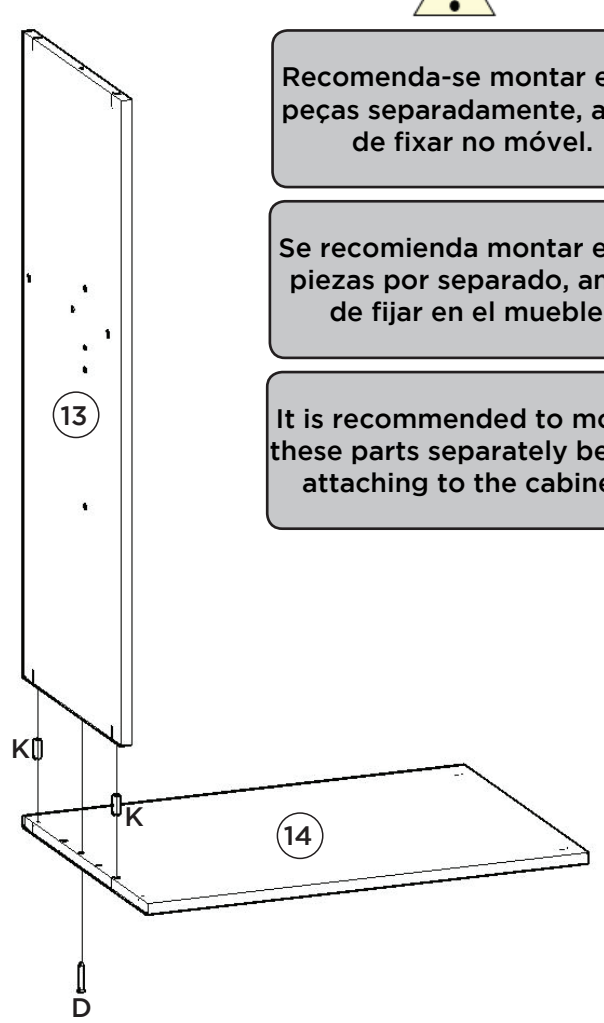

Recomenda-se montar estas peças separadamente, antes de fixar no móvel.

Se recomienda montar estas piezas por separado, antes de fijar en el mueble.

It is recommended to mount these parts separately before attaching to the cabinet.

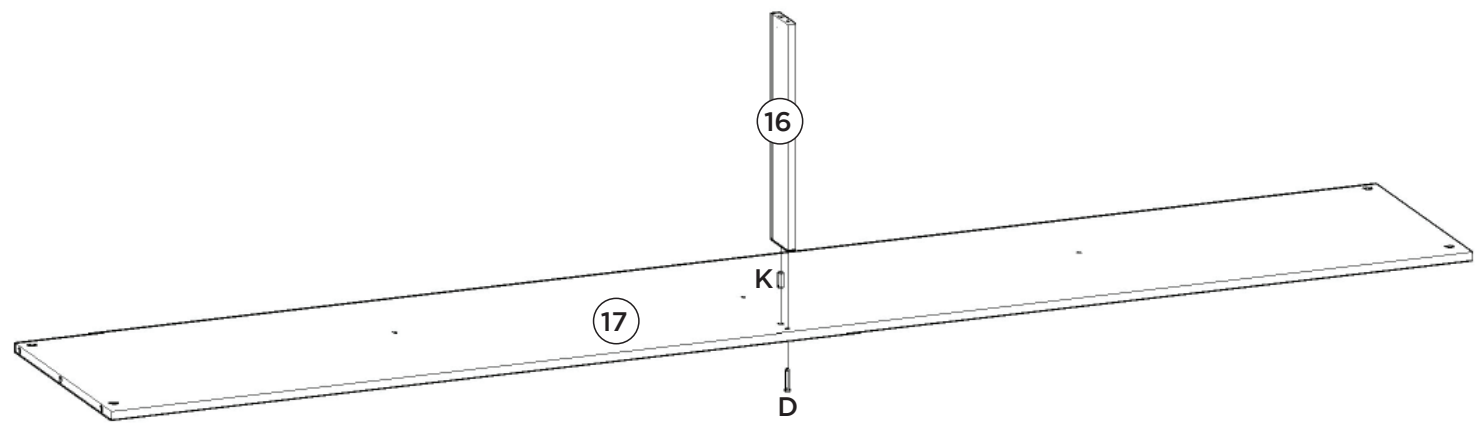

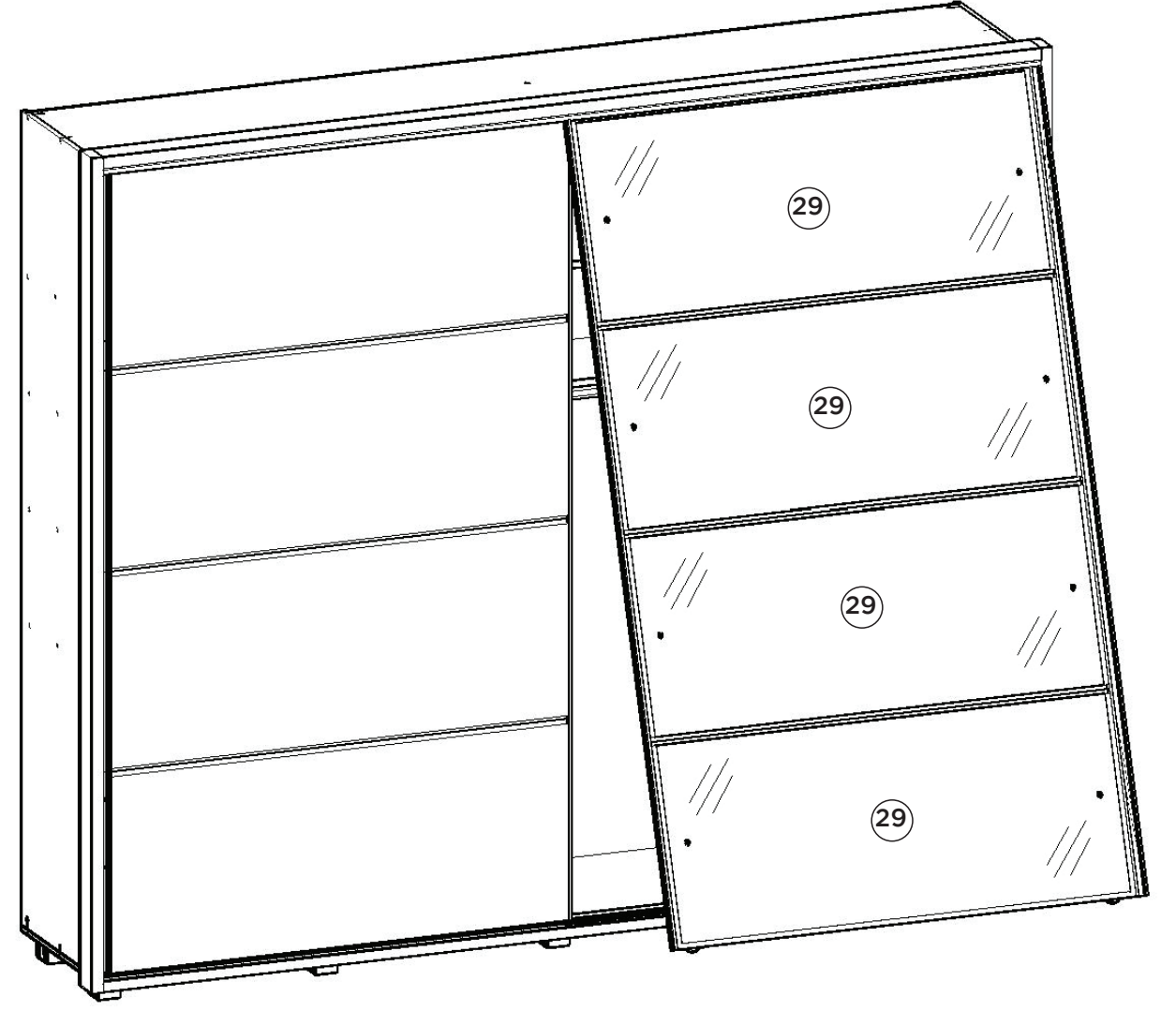
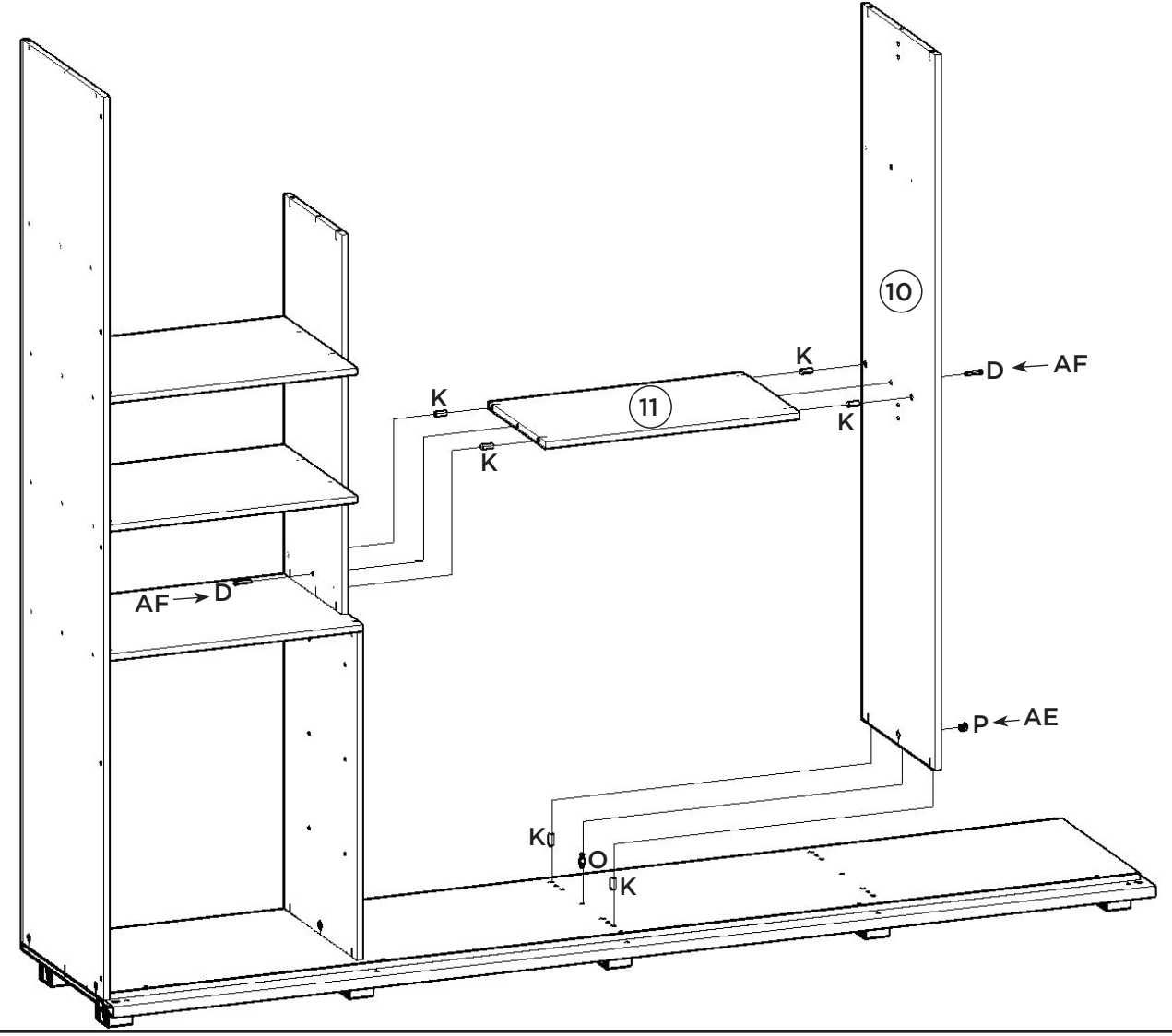
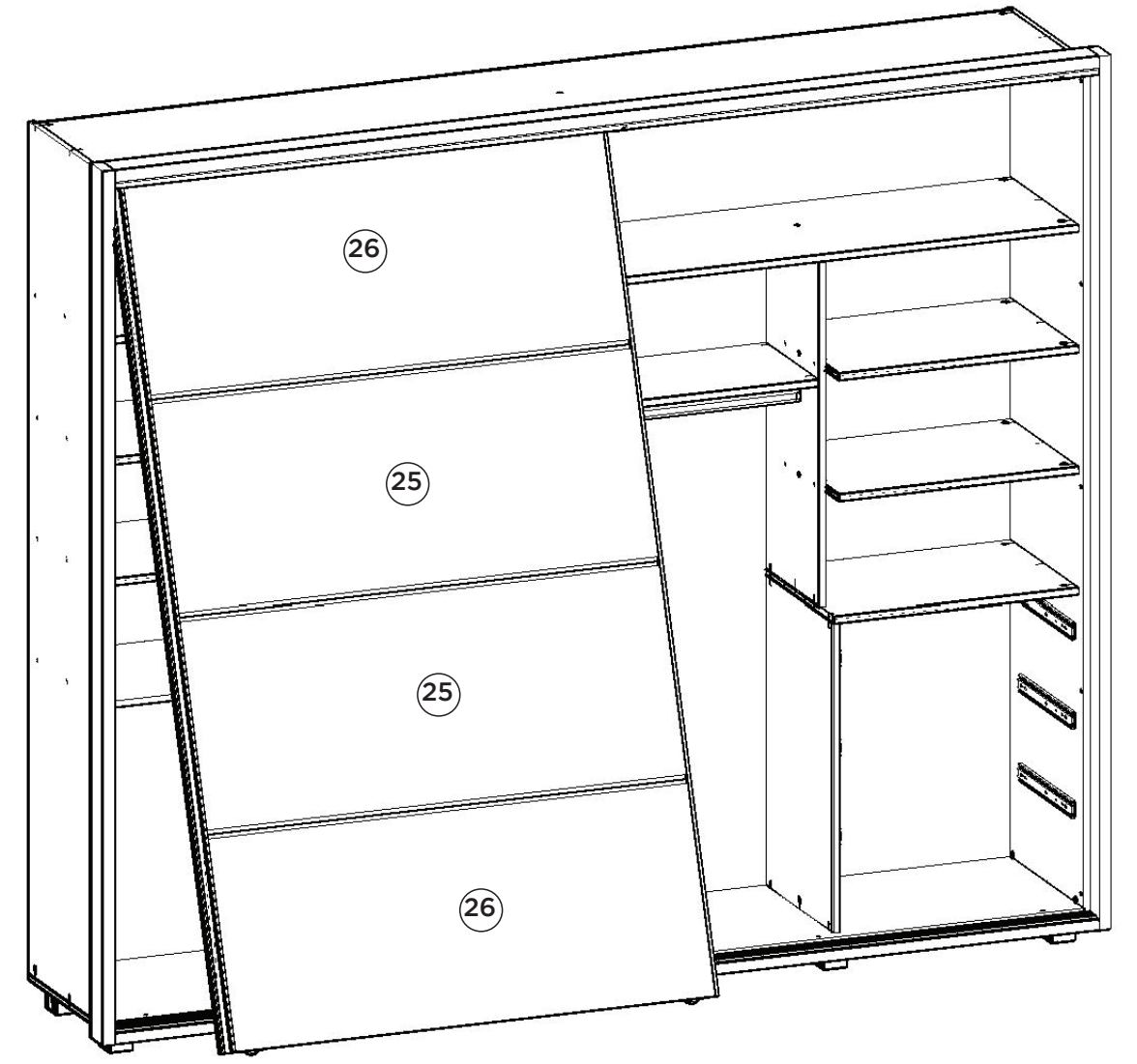
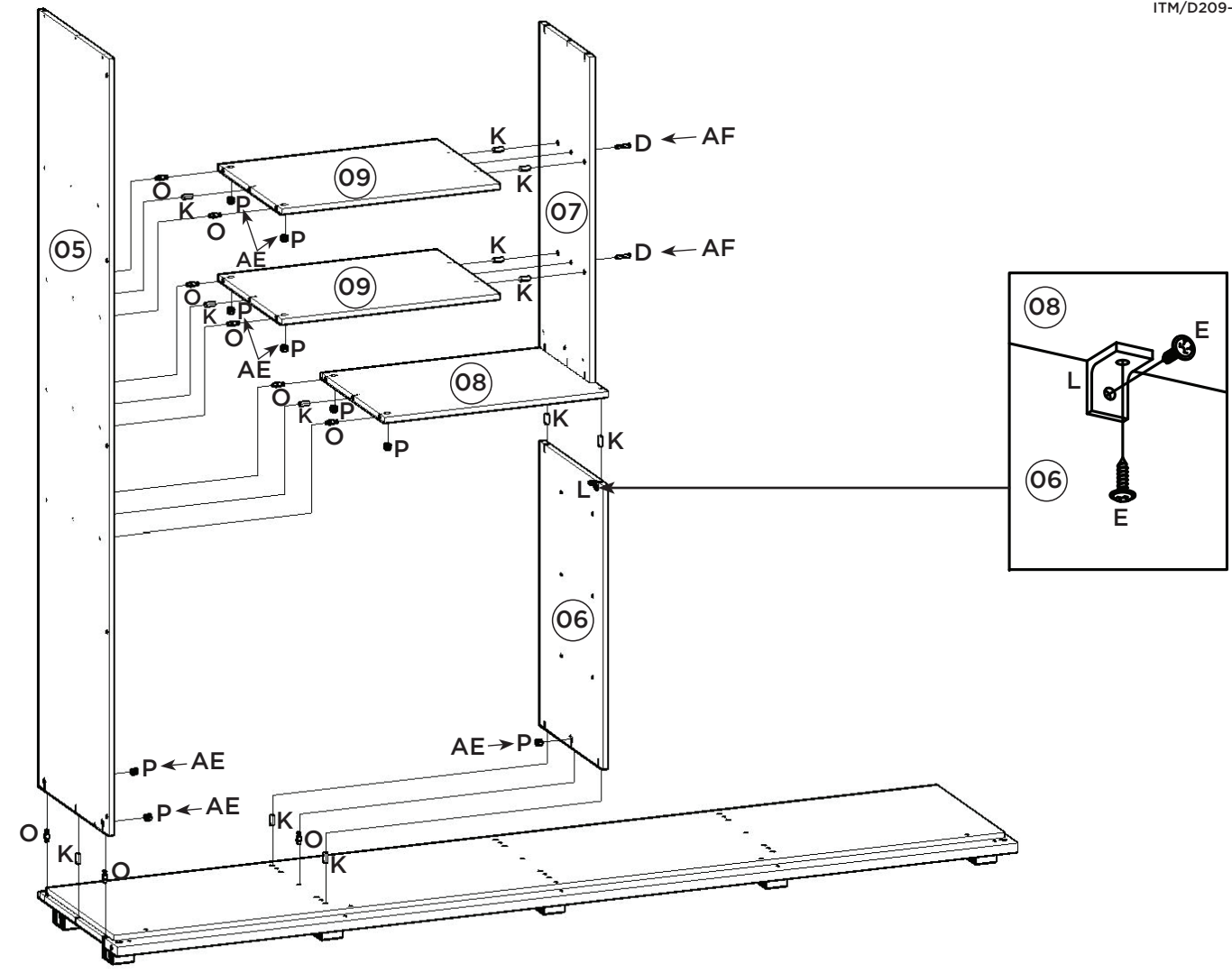

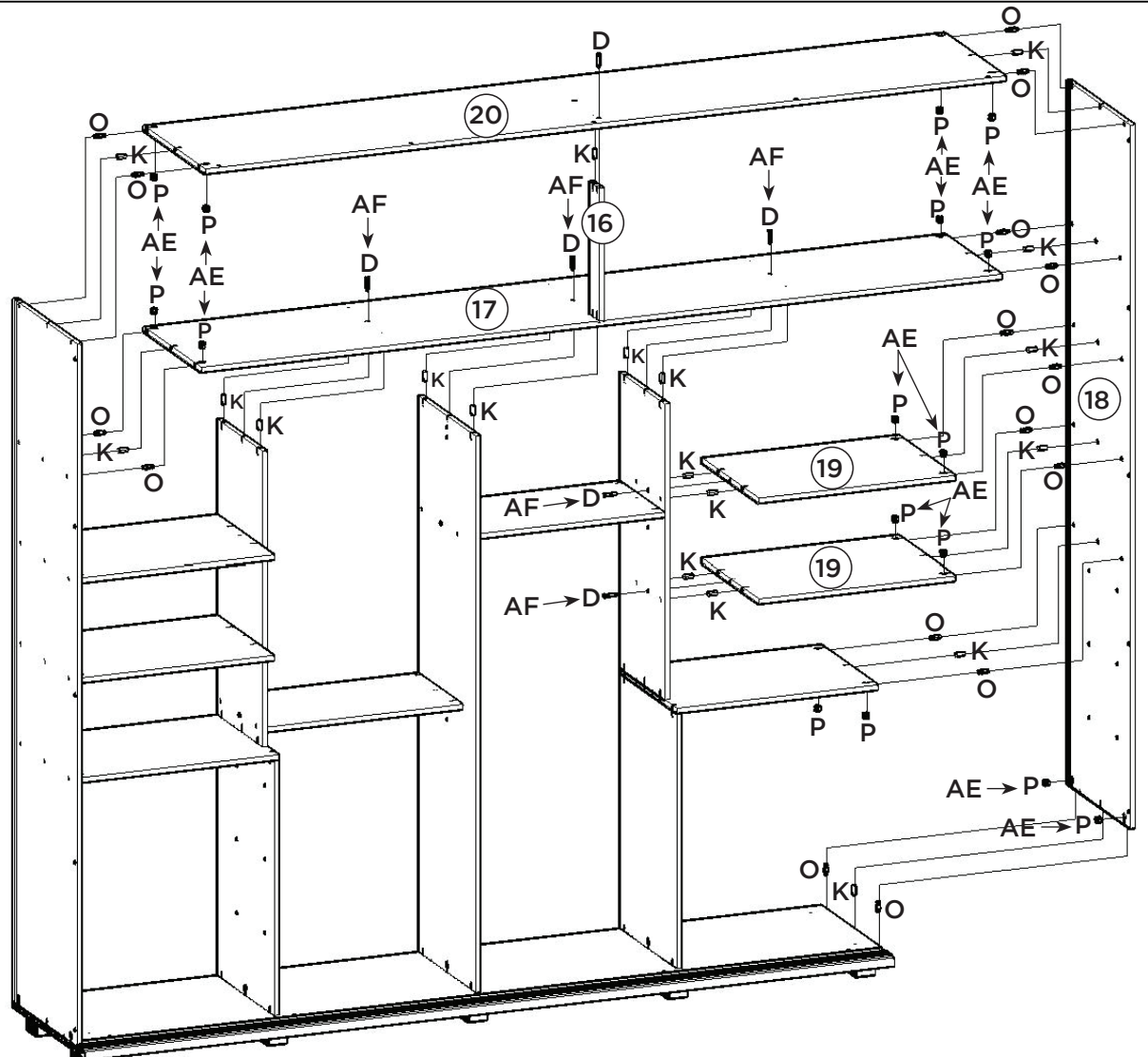
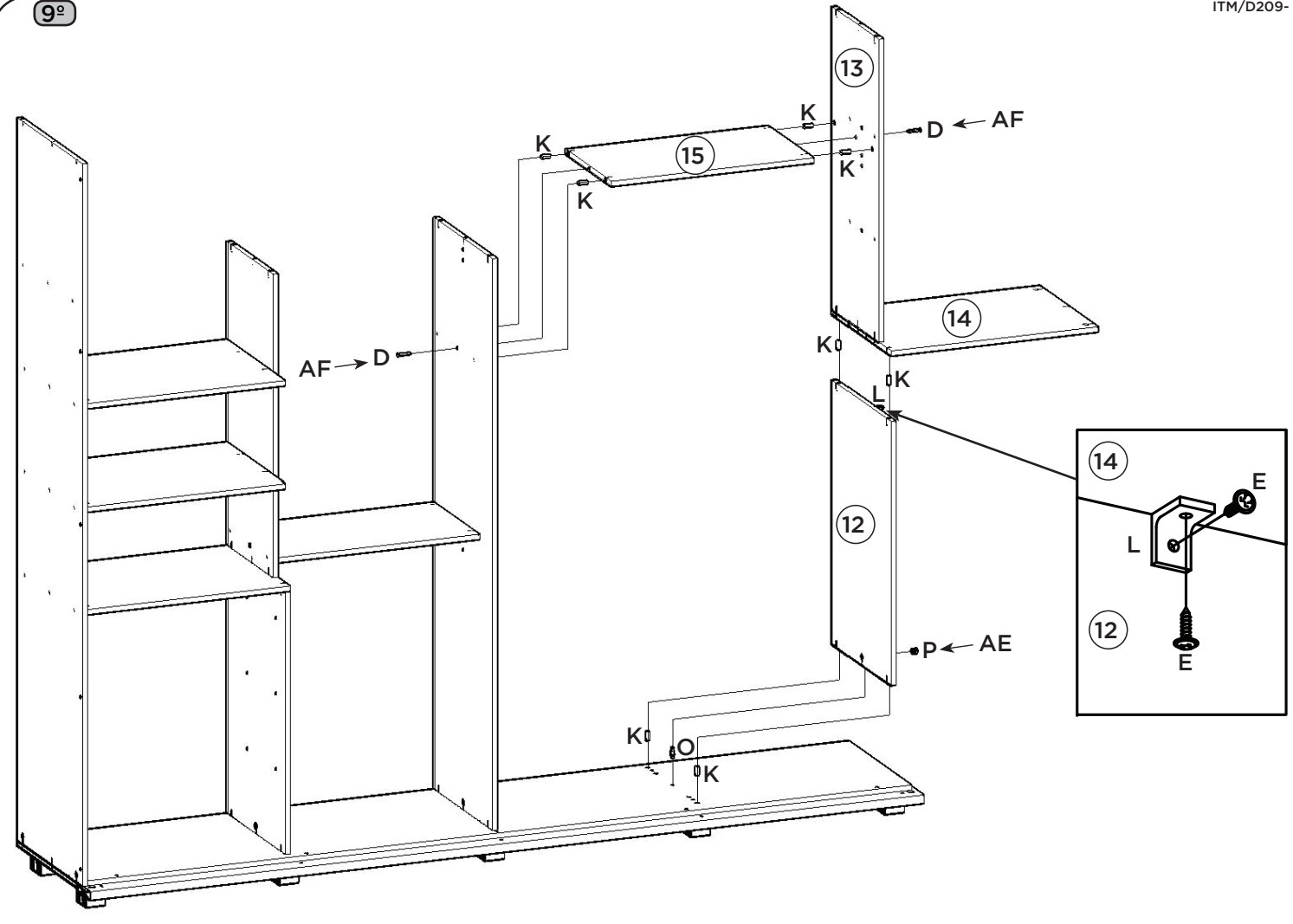
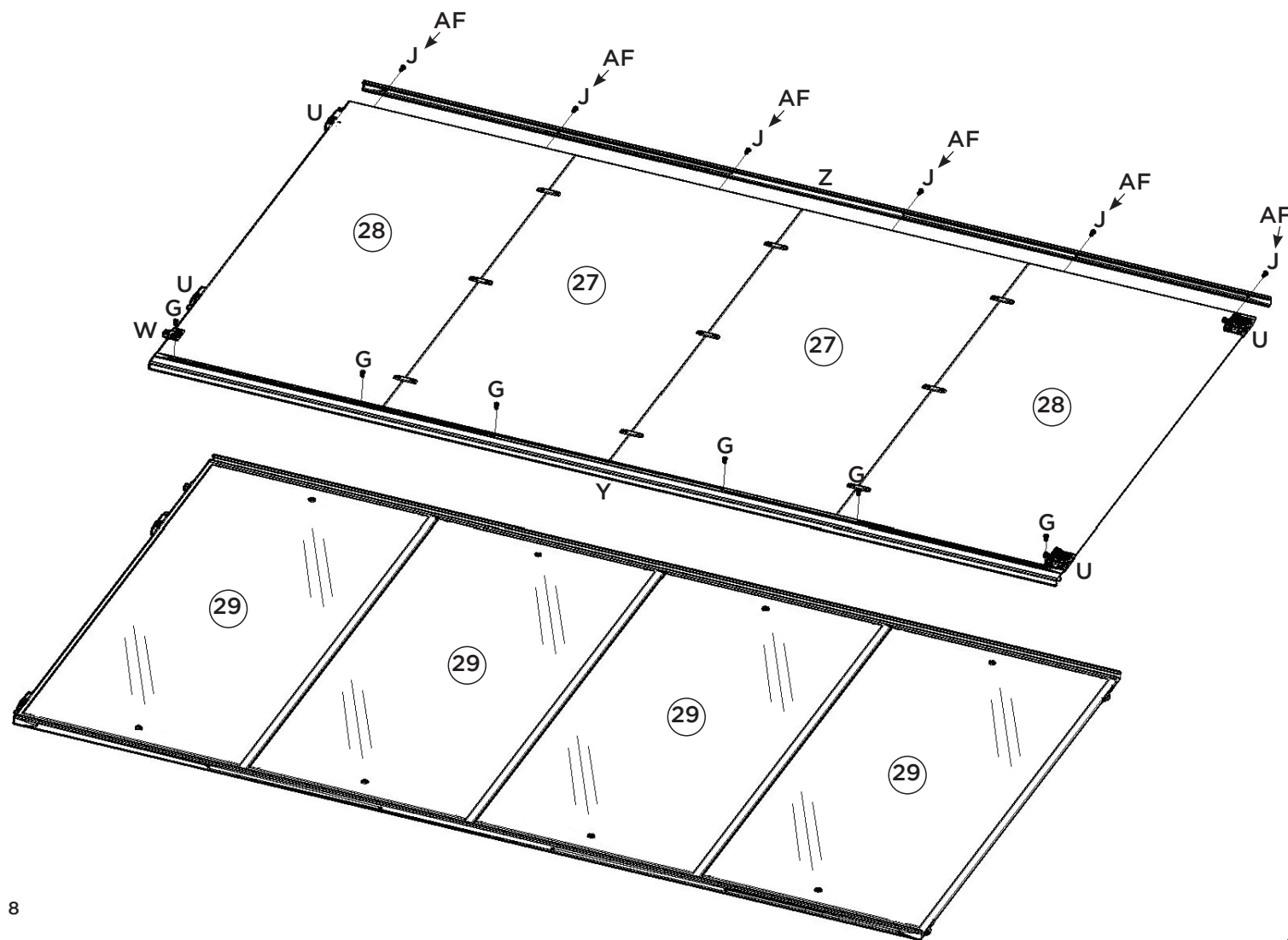
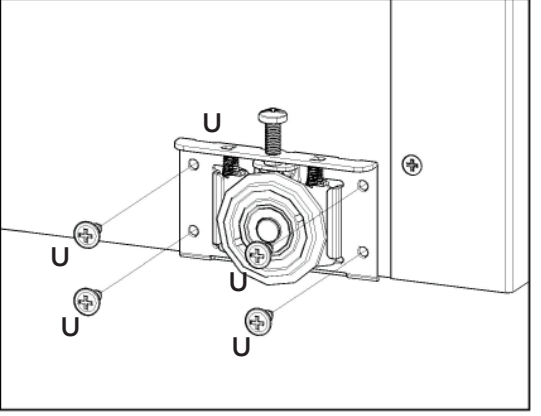
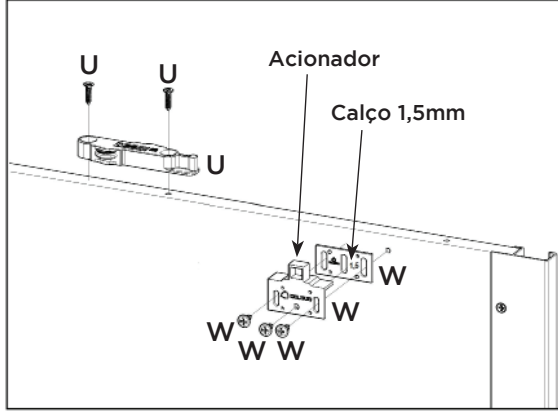
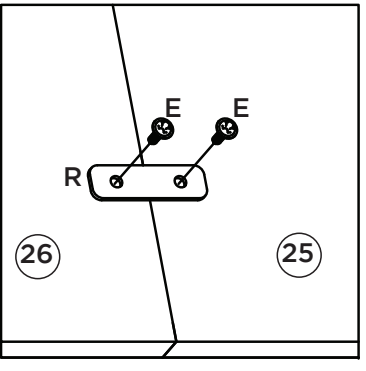
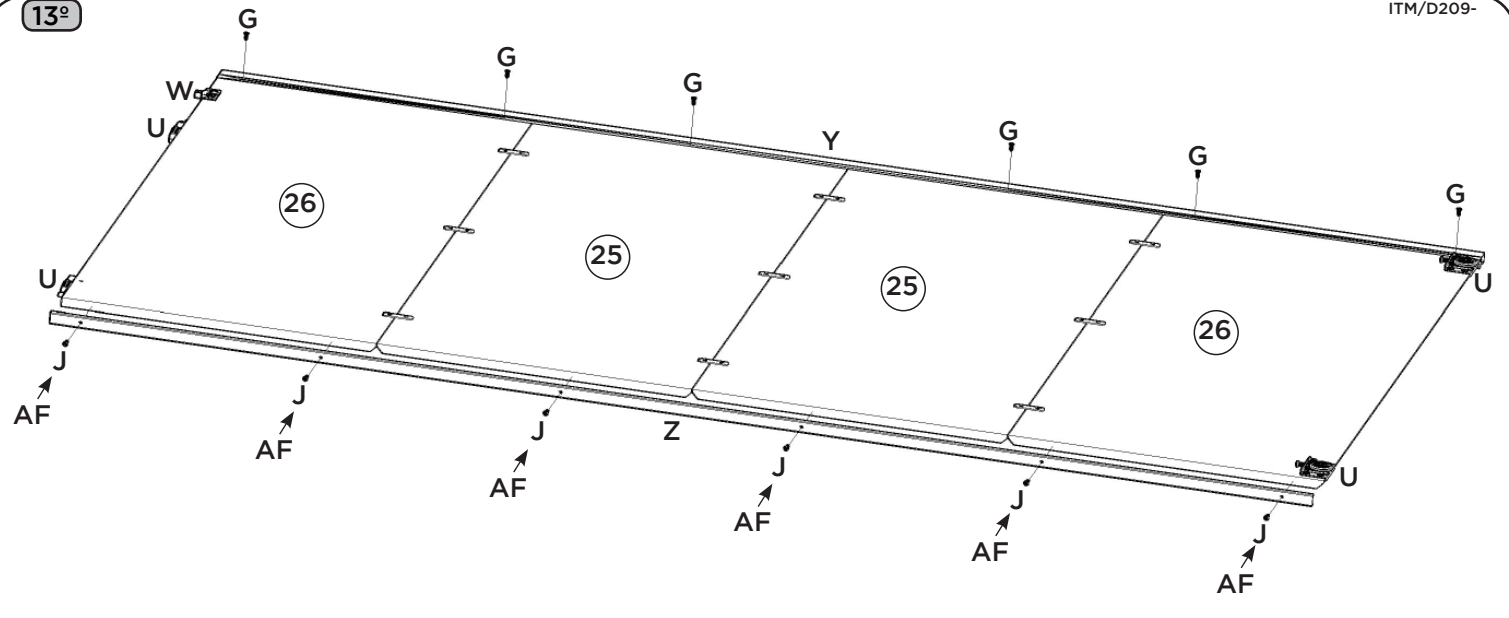

Colocar os parafusos (I) a uma distância de 100mm de um para outro.

Colocar los tornillos (I) a una distancia de 100 mm de uno a otro.

Place the screws (I) at a distance of 100mm from one another.

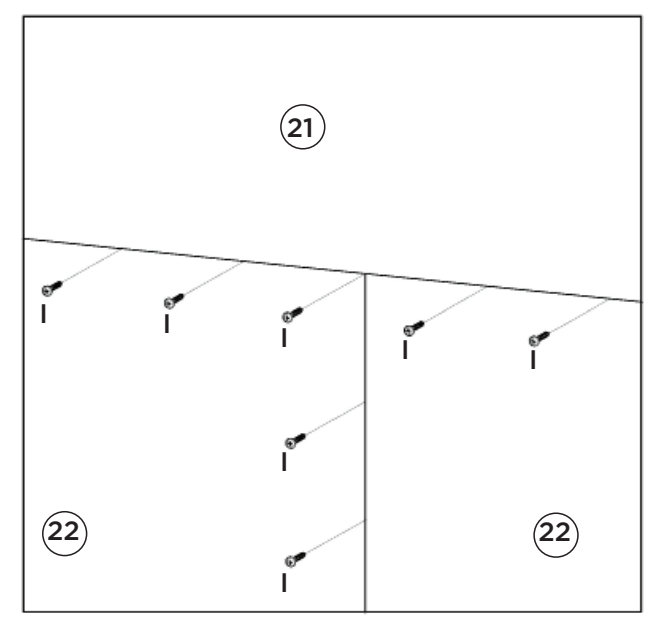
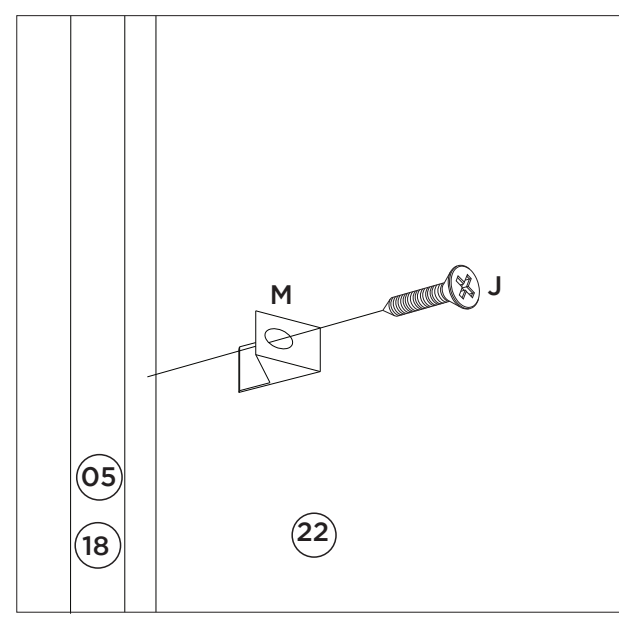
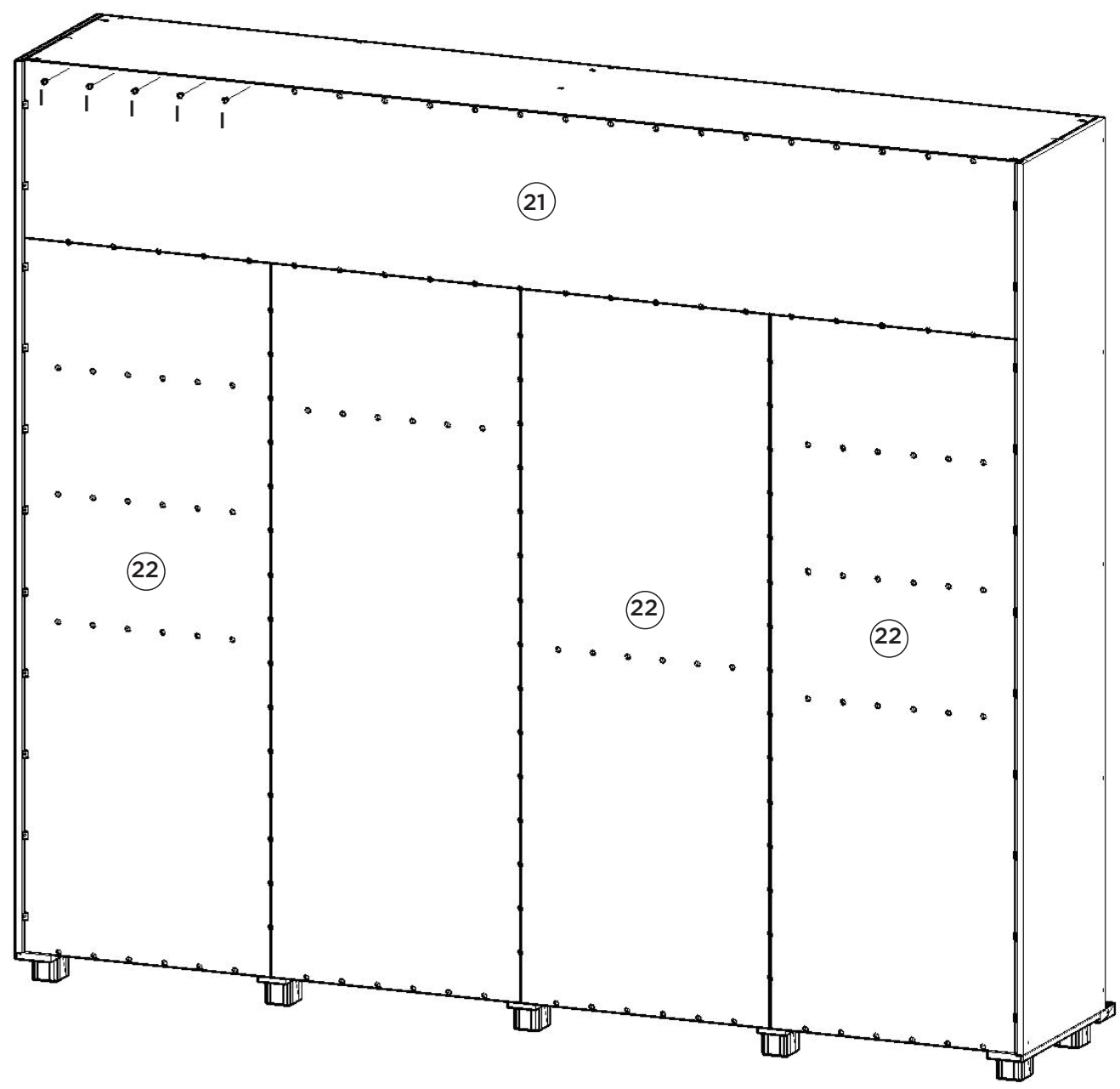

Os Trilhos (AA e AB) deverão ser fixados depois que as Molduras (23 e 24) estiverem acopladas ao produto.  
 Los rails (AA y AB) deben fijarse después de que los marcos (23 y 24) estén acoplados al producto.  
 The Rails (AA and AB) should be secured after the Frames (23 and 24) are attached to the product.



- Kit Amortecedor (W)
- Freio do Kit (U)
- Kit de amortiguador (W)
- Freio do Kit (U)
- Kit Shock Absorber (W)
- Freio do Kit (U)

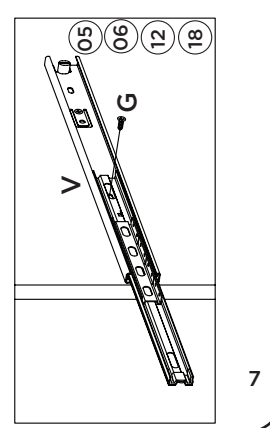
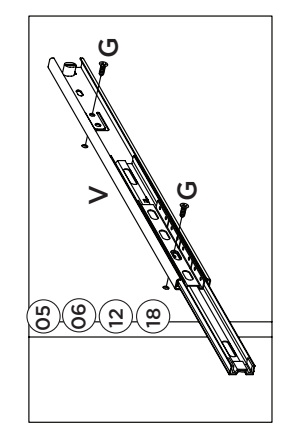
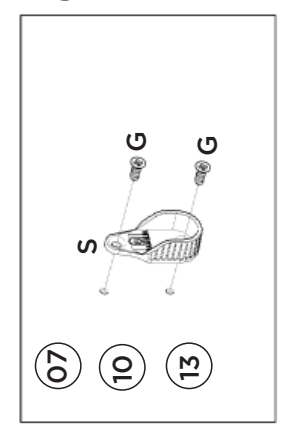
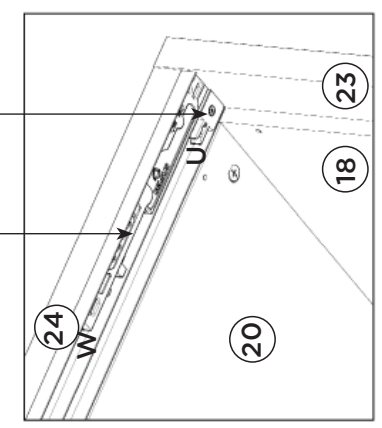
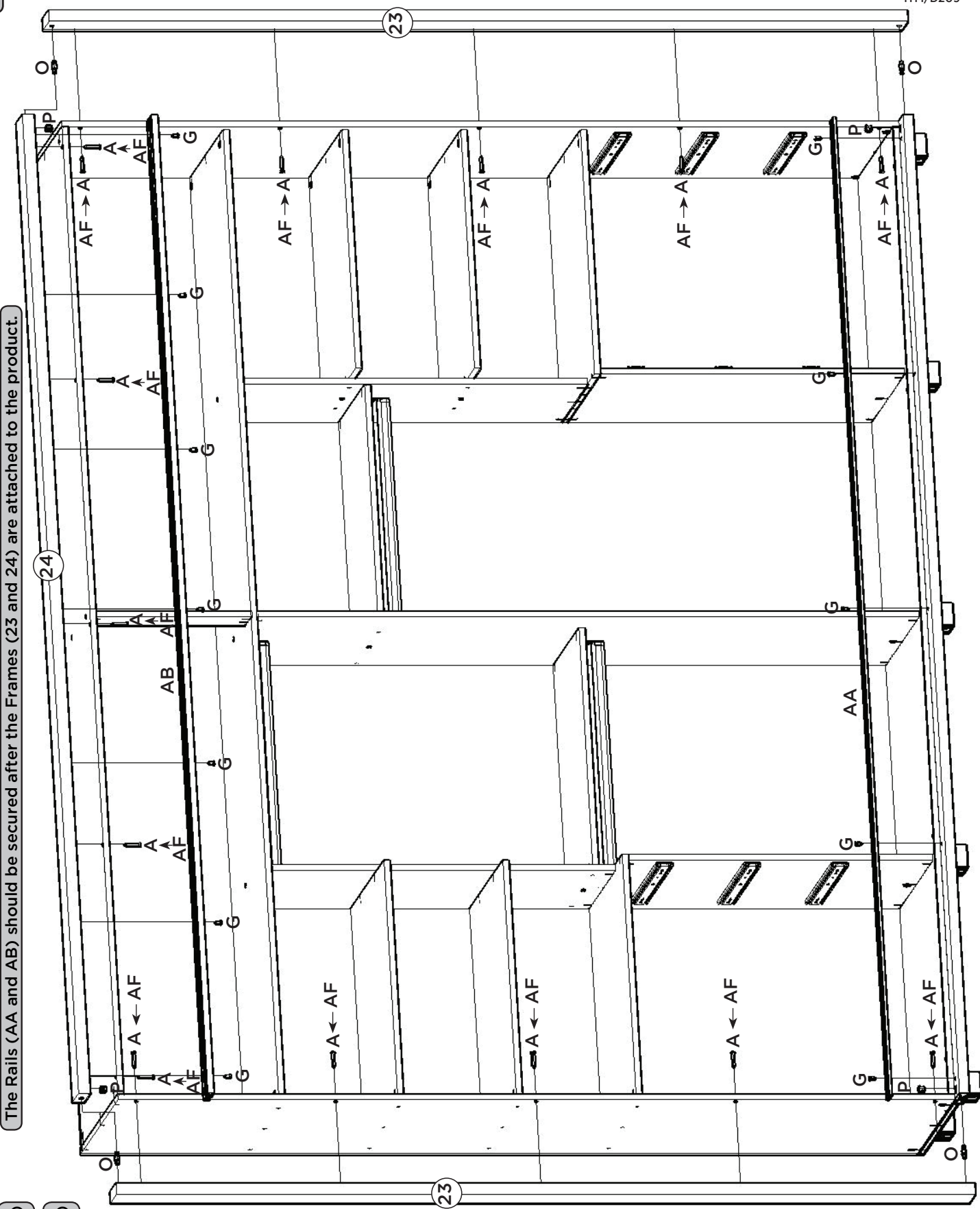

# Agora que você já comprou o seu móvel, ele merece ser montado do jeito certo.

Erros de montagem causam mais de **60%** dos danos em móveis.

## Por que contratar?

Tranquilidade do **início ao fim** da montagem



### PROFISSIONAIS QUALIFICADOS

Especialistas certificados na **MadeiraMadeira Serviços**.



### FERRAMENTAS PROFISSIONAIS

que **protegem** seus móveis.



### AGENDAMENTO EM 24 HORAS

escolha a data e o turno **ideais para** você.



### GARANTIA DE 3 MESES

de cobertura **completa**.

**Mais de 1 MILHÃO DE MONTAGENS**  
★ com avaliação **4.7** ★

#### Mariana S., São Paulo

"Chegaram no horário e montaram tudo rapidamente. Serviço incrível!"



#### Carlos R., Belo Horizonte

"Tentei montar sozinho e foi um desastre. Com a **MadeiraMadeira Serviços** ficou perfeito."



#### Ana P., Rio de Janeiro

"Agendamento ágil e **montagem pontual e perfeita**. Recomendo demais!"



## Agende agora pelo QR Code

Madeira**Madeira** Serviços · Atendimento em todo o Brasil



Escaneie o QRCode