

## Capacidade de Carga - Load Capacity - Capacidad de carga

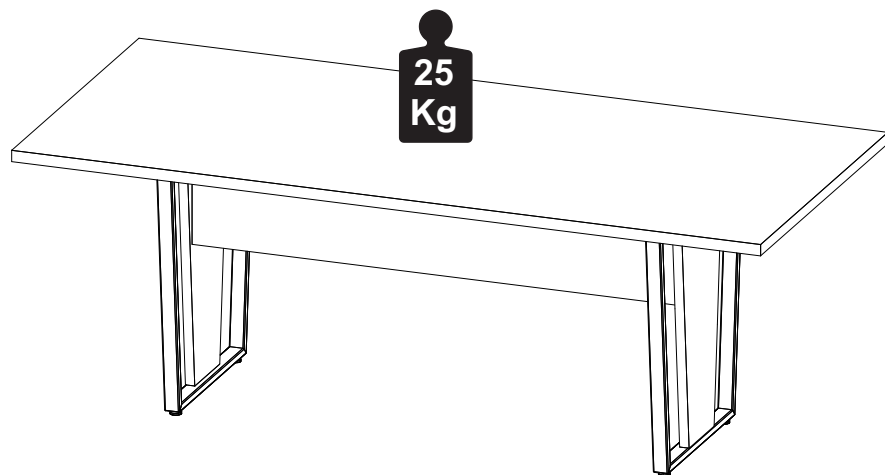

### Manutenção e Limpeza

Vidros: pano levemente umedecido com álcool, seguido de pano seco.  
Madeiras: pano levemente umedecido com água, seguido de pano seco.  
\*Nunca utilizar produtos químicos ou abrasivos.

### Maintenance and Cleaning

Glasses: cloth lightly moistened with alcohol, followed by dry cloth.  
Woods: cloth slightly moistened with water, followed by cloth seo.  
\*Never use chemicals or abrasives.

### Mantenimiento y Limpieza

Vidrios: legeramente humedecido con alcohol, seguido de un paño seco.  
Madera: ligeramente humedecido con agua, seguido de un paño seco.  
\*No utilice nunca productos quimicos o abrasivos.

## INSTRUÇÕES DE MONTAGEM ASSEMBLY INSTRUCTIONS INSTRUCCIONES DE MONTAJE MESA DE REUNIÃO CONFERENCE TABLE MESA DE CONFERENCIA

YAR2191

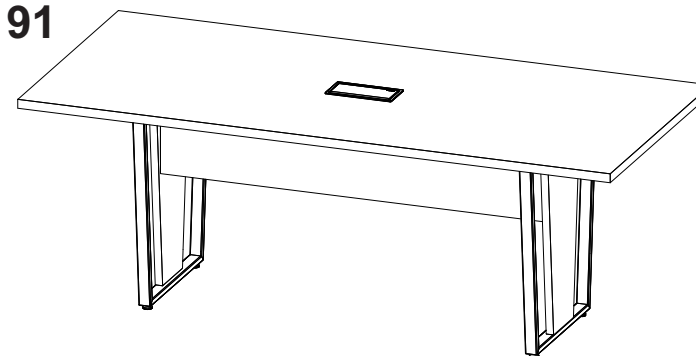

YAR2190

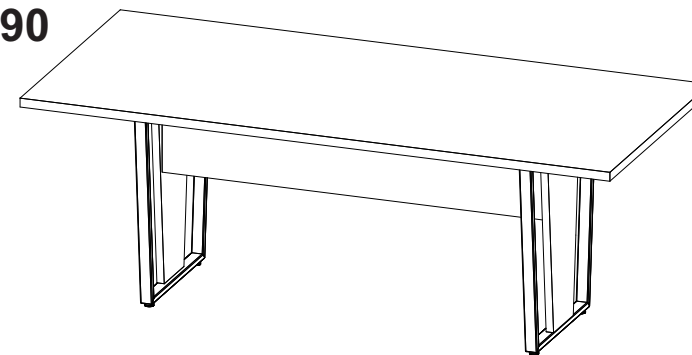

REF. #YAR2190-YAR2191



15mim

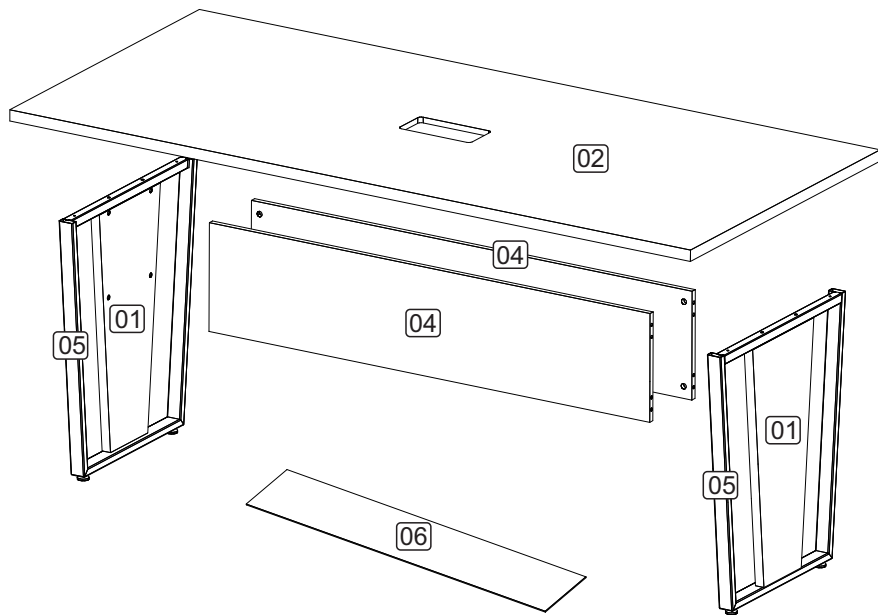

### LISTA DE PEÇAS

- 01 - Aplique
- 02 - Tampo
- 04 - Painel Frontal
- 05 - Pé Metálico
- 06 - Travessa

### LISTA DE PIEZAS

- 01 - Marco lateral
- 02 - Tapa
- 04 - Panel Delantero
- 05 - Lateral Metálica
- 06 - plato

### PARTS IDENTIFICATION

- 01 - Side frame
- 02 - Top
- 04 - Front Panel
- 05 - Metallic Side
- 06 - Platter

4

### POSICIONAMENTO DO TAMPO POSICIONAMIENTO DE LA TAPA

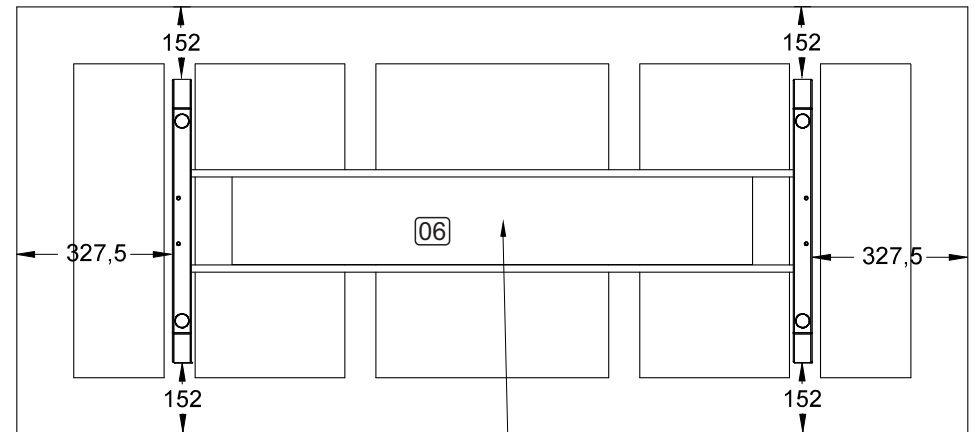

Encaixe o a travessa 06 sobre os pinos, fixados no painel frontal.

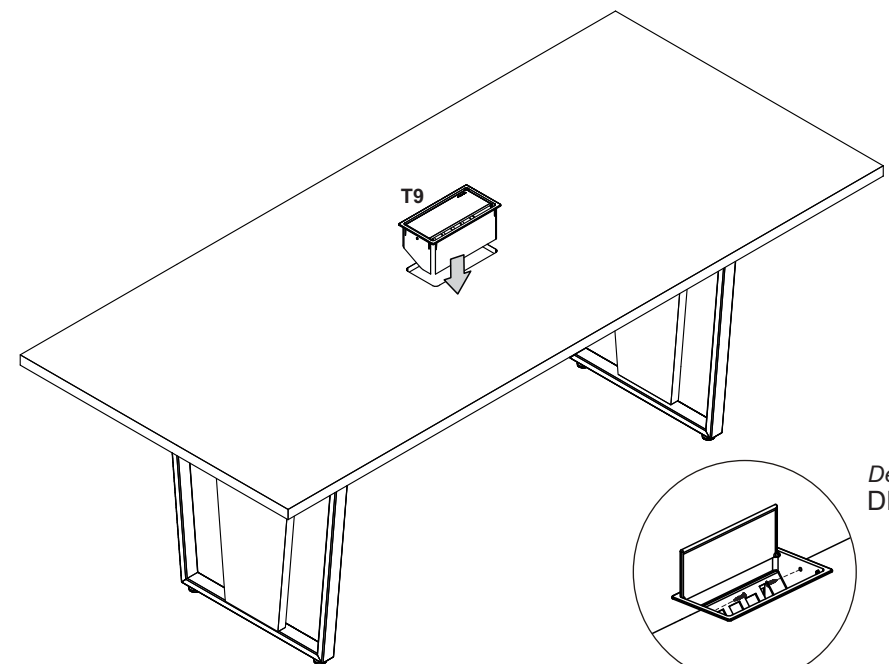

Detalle / Detail  
DETALHE 1

**Somente no item YAR2191**  
**Just no item YAR2191**

**Ver manual de montagem da caixa.**  
**Consulte el manual de montaje de la caja.**  
**See box assembly manual.**

3

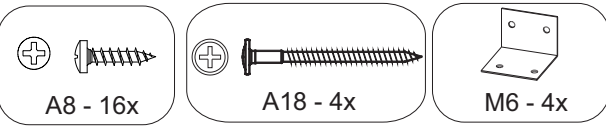
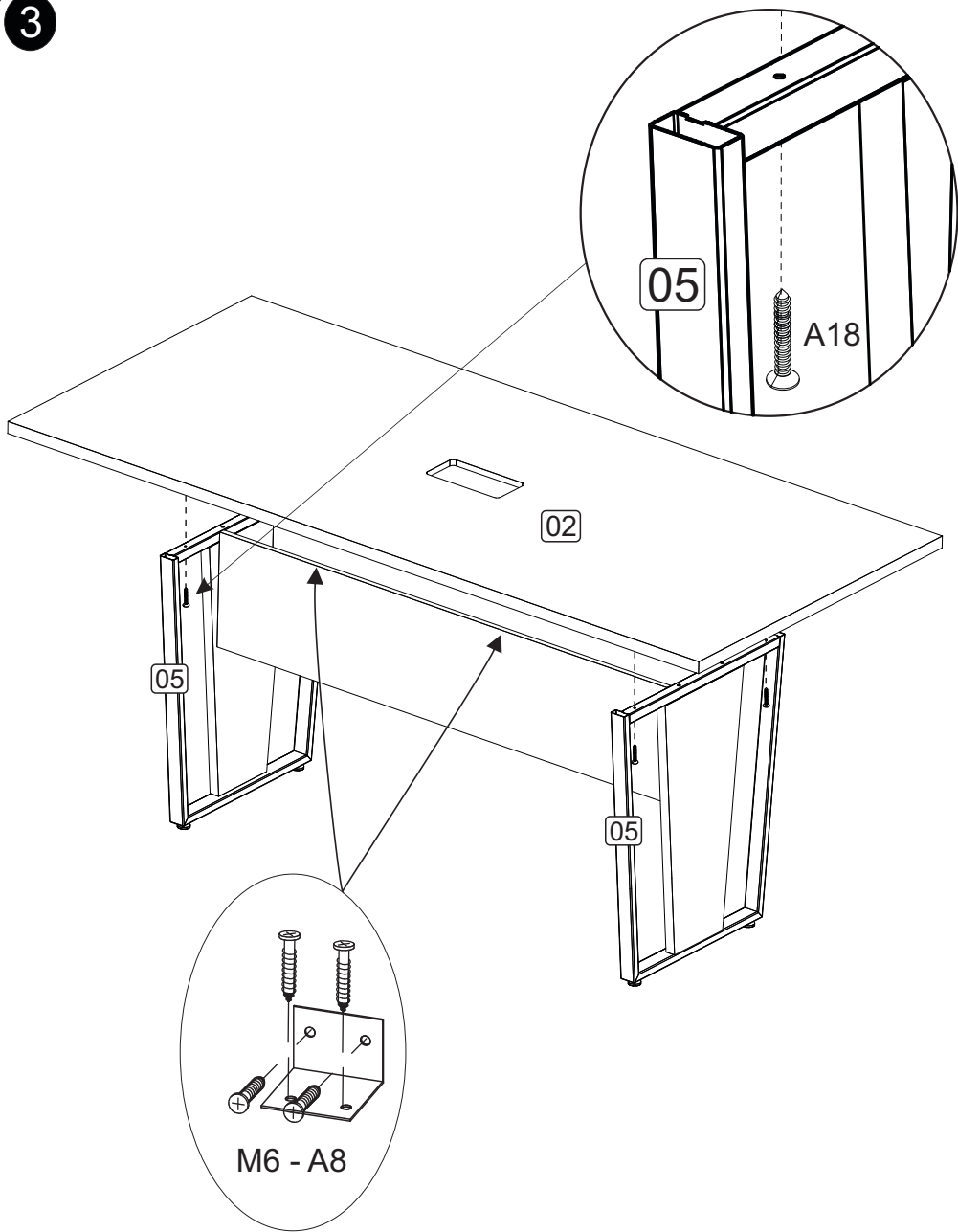

# ACESSÓRIOS ACCESSORIES ACCESORIOS

A8 - PARAF. 4,0x14 CP  
**16x**



A18 - PARAF. 4,0x45 CF  
**4x**



A15 - PARAF. 4,0x40 CP  
**8x**



A29 - PARAF. MINIFIX  
M6x33m **8x**

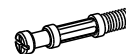

A35 - TAMBOR  
MINIFIX **8x**



A36 - BUCHA M6x33  
**8x**



M6 - CANTONEIRA L  
04 FUROS **4x**



L2 - SAPATA PLAST.  
SEXT. **4x**



L5 - BUCHA PLÁSTICA  
P/SAPATA 5/16 **4x**



B2 - SUPORTE PRAT.  
8x7 **8x**



# 1 PRÉ-MONTAGEM

Preasamblea  
Pre-assembly

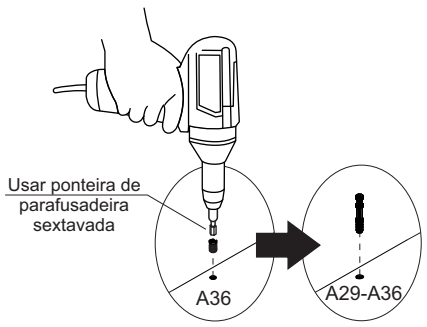
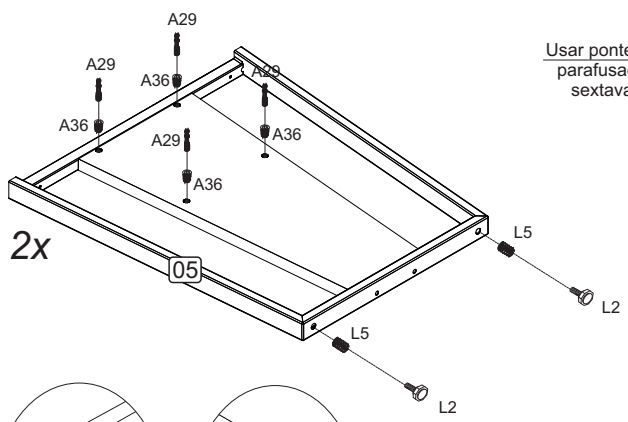
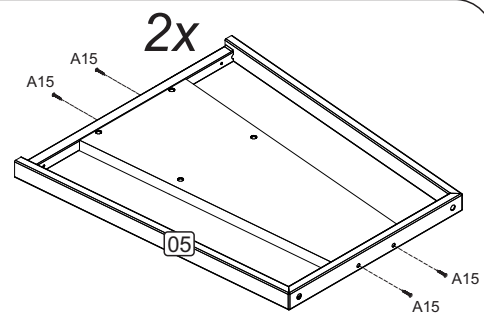
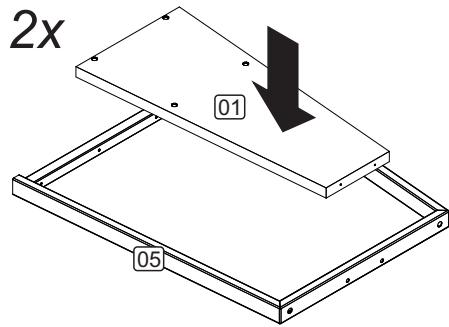

Usar ponteira de parafusadeira sextavada

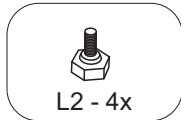
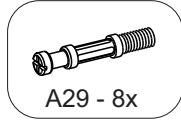
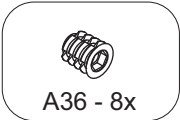
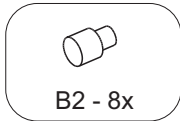
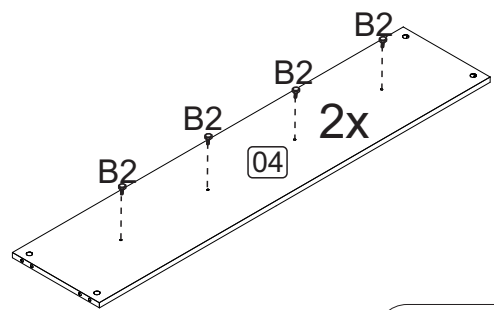
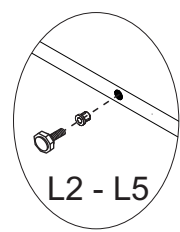
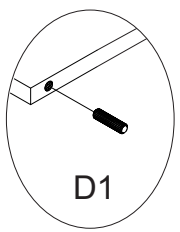

# 2 MONTAGEM

Armado  
Assembly

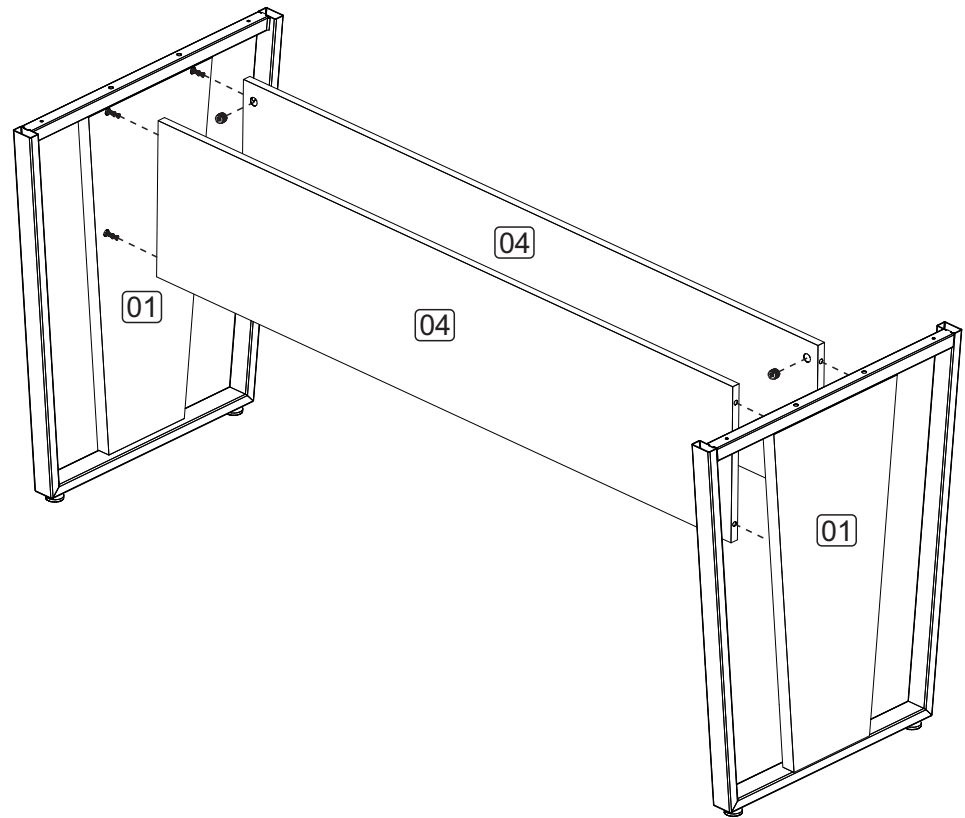

Depois de encaixar as peças coloque o tambor com a sua seta voltada para o parafuso. Para apertar Gire no sentido horário.  
Después de colocar las piezas, coloque el tambor con su flecha hacia el tornillo. Para apretar, gire en sentido horario.  
After fitting the parts, place the drum with its arrow facing the screw. To tighten, turn clockwise.

