



DP-001-2484 **Instruções de Montagem** / Instrucciones de Armado / Assembly Instructions

2484 - BERÇO MINI CAMA C/ PERFIL DOCE SONHO

2484 - CUNA MINI CAMA CON UN PERFIL DOCE SONHO

2484 - COT MINI BED WITH PROFILE DOCE SONHO

Atualização 1
Actualización / Update
21/06/2016

Legendas de Peças / Legends of Parts / Leyenda de Piezas

CÓD	DESCRIÇÃO	DESCRIPTION	DESCRISIONES	QTD	DIMENSÃO
2486	CABECEIRA	HEADBOARD	CABECERA	2	960 X 780
2801	GRADE	GRID CRIB	CUADRÍCULA CUNA	2	1300 X 666
931	TRAVESSA BERÇO	BATTEN CRIB	TRAVESSA CUNA	2	1300 X 49
932	BASE DO COLCHÃO	BASE MATTRESS	COLCHÓN DE BASE	7	183 X 680
945	BARRA	BAR CREADLE	BARRA CUNA	2	1300 X 97

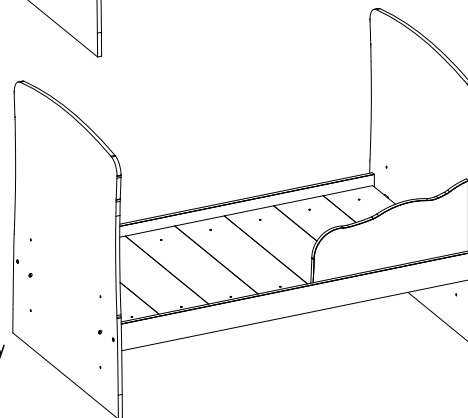
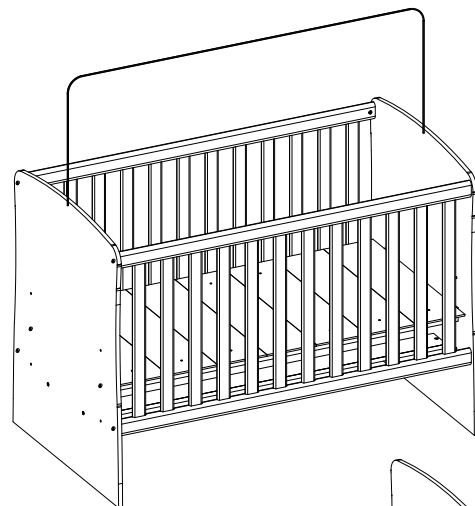
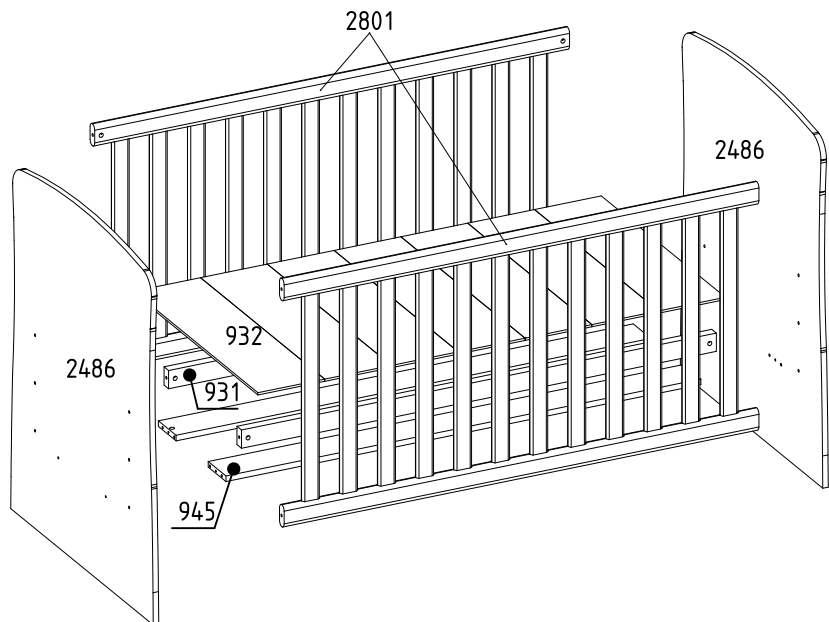

Colchão / Colchón / Mattress

Densidade Mínima:
Densidad Mínima / Minimum Density:
D-18

Medidas / Medidas / Measures:
700mm X 1300mm X 120mm

NOTA: Produto não contém tampa furo para maior segurança e conformidade com a Norma.
NOTA: el Producto no contiene tapa el agujero para mayor seguridad y de conformidad con la Norma.
NOTE: Product does not contain stap hole for added security and compliance with the Standard.

Instrução

01 - Utilize a embalagem para forrar o chão e iniciar a montagem;
02 - Separe as peças colocando em pé, nunca empilhe uns sobre os outros;
03 - Identifique as peças do móvel antes de iniciar a montagem;
04 - Caso a montagem for feita com parafusadeira com pressão de 5 Newtons, finalizando o aperto manual com chave, para primeira montagem, em caso de ensaio ou remontagem gerar reaperto manual das fixações.
05 - Aconselhamos que a montagem seja feita por montador profissional.

01 - Utilizar el material de embalaje para cubrir el suelo e iniciar el montaje.
02 - Separar las piezas que ponen en pie, nunca se apilan unas sobre otras.
03 - Identificar las partes móviles ante de comenzar ensamblaje.
04 - Si el montaje se realiza con una presión de apriete a 5 newtons, nalizó los tornillos con una llave de la primera asamblea. para la vericación o el reensablaje generar manual de volver a apretar las jaciones.
05 - Se recomienda que el montaje se realiza por un instalador profesional.

01- Use packaging material to cover the oor and start the assembly
02 - Separate the pieces putting on foot, never stack on each other.
03 - Identify the mobile parts ans their numbers before starting assembly.
04 - If the assembly is done with tightening pressure to 5 newtons, nalized the thumbscrews with a key to the rst assembly. for testing or reassembly generate manual retightening the xings.
05 - We recommend that the mounting is done by a professional tter.

*Ao solicitar peças para Assistência Técnica ao lojista, informe o código do produto, a cor, o número da peça danificada e o lote.
* Em caso de dúvidas, ou informações adicionais, mande-nos um e-mail para qmovi@qmovi.com.br ou entre em contato com a loja.
* Visite: www.qmovi.com.br

*Cuando solicite piezas para asistencia técnica al tendero, introduzca el código del producto, el color, el número de pieza dañado y el lote.
* Si tiene alguna pregunta, o agrega información, envíenos un correo electrónico a qmovi@qmovi.com.br o ingrese a la tienda.
* Visit: www.qmovi.com.br

* When requesting parts for technical assistance to the shopkeeper, enter the product code, color, damaged part number and batch.
* In case of questions, or additional information, send us an email to qmovi@qmovi.com.br or contact the store.
* Visit: www.qmovi.com.br

2549

Qt.:12



2547

Qt.:4



2543

Qt.:2



2430

Qt.:18

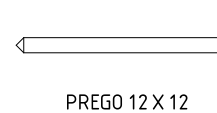

0144

Qt.:1



0030

Qt.:4



0208

Qt.:12

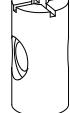

0034

Qt.:8

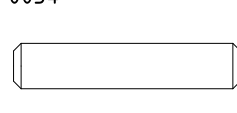

0213

Qt.:4

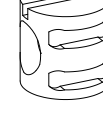

01

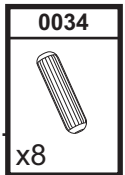
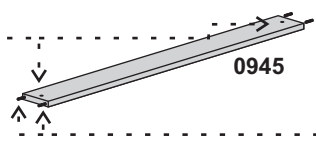
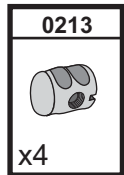
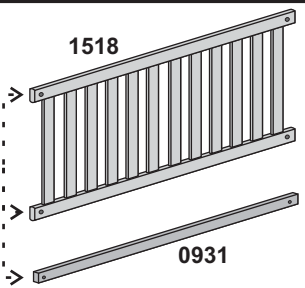
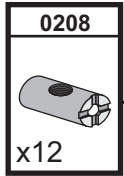
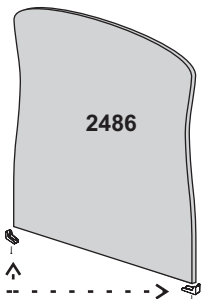
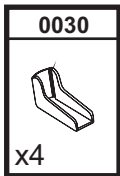

02

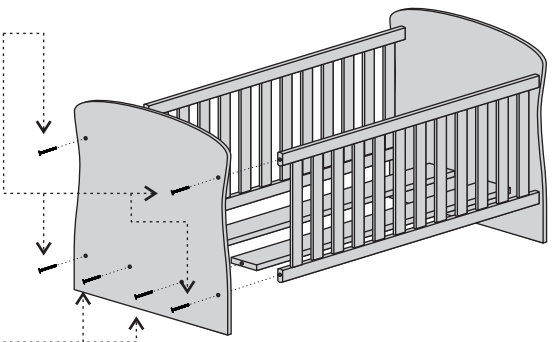
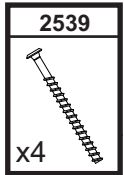
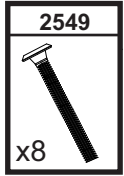

03

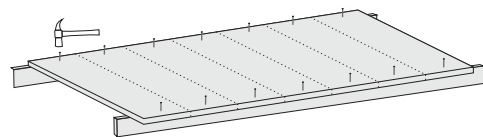
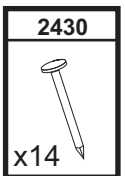
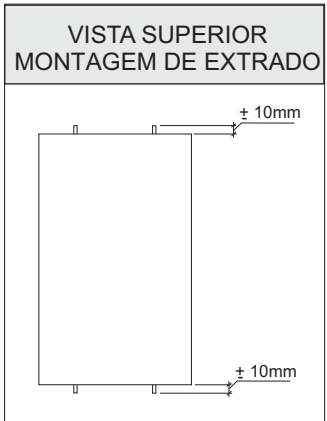

04

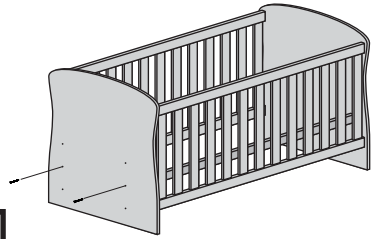
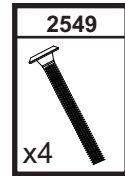

05

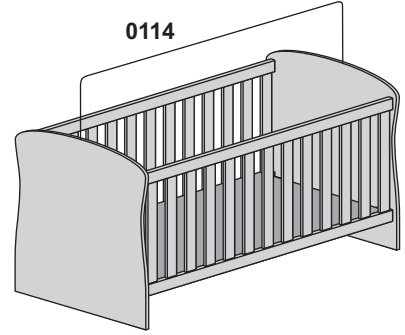

01

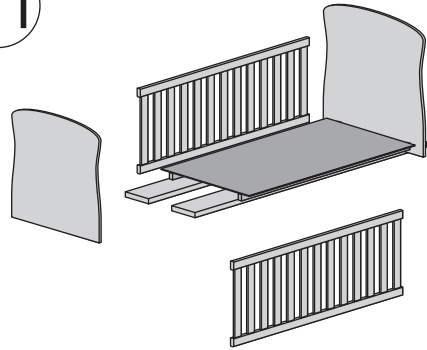

02

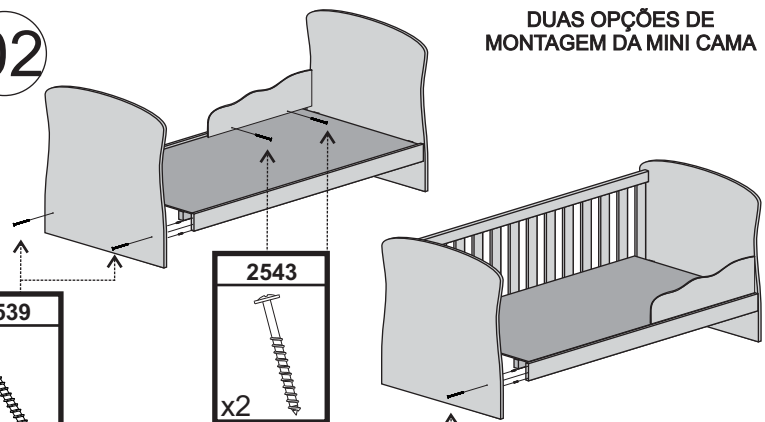
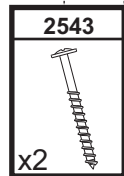
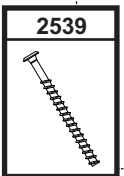

DUAS OPÇÕES DE MONTAGEM DA MINI CAMA

03

