

LISTA DE PEÇAS / Pieces List / Lista de Piezas

SEQ.	REF.	DESCRIÇÃO	DESCRIPTION	DESCRIPCIÓN	MAT.PRIMA	COMP.	LARG.	ESP.	QTD.
1	10523	BASE	BASE	BASE	MDP	1460	540	15	1
2	10524	RODAPÉ FRONTAL	FRONT FOOTING	ZOCALO FRONTAL	MDP	1460	88	15	1
3	10525	SUPORE RODAPÉ	SUPPORT FOOTWEAR	SOPORTE RODAPÉ	MDP	498	88	15	1
4	10526	RODAPÉ TRASEIRO	BACK FOOTING	ZOCALO TRASEIRO	MDP	1460	88	15	1
5	10527	LATERAL ESQUERDA	LET SIDE	LATERAL IZQUIERDO	MDP	2180	540	15	1
6	10528	PRATELEIRA ESQ INF	LOWER LEFT SHELF	PRATELERA IZQUIERDA INFERIOR	MDP	723	150	15	1
7	10529	DIVISÃO	DIVISION	DIVISORÍA	MDP	1990	450	15	1
8	10530	PRATELEIRA SUPERIOR	TOP SHELF	PRATELERA SUPERIOR	MDP	723	448	15	2
9	10531	LATERAL DIREITA	RIGHT SIDE	LATERAL DERECHO	MDP	2180	540	15	1
10	10533	TAMPO GAVETEIRO	TAPSET COVER	TAMPO GAVETEIRO	MDP	723	448	15	1
11	10534	PRATELEIRA MENOR	SHELF MINOR	PRATELERA MENOR	MDP	723	360	15	2
12	10535	CHAPÉU	HAT	HAT	MDP	1460	540	15	1
13	10536	VISTA SUPERIOR	UPPER VIEW	VISTA SUPERIOR	MDP	1490	130	15	1
14	10537	SUPORE GAVETA DIR	RIGHT DRAWER SUPPORT	SOPORTE GORRO DERECHA	MDP	320	445	25	1
15	10538	SUPORE GAVETA ESQ	LEFT DRAWER SUPPORT	SOPORTE GAVETA IZQUIERDA	MDP	320	445	25	1
16	10539	FRENTE DE GAVETA	DRAWER FRONT	FRENTE CAJÓN	MDP	664	130	15	2
17	10540	LATERAL DE GAVETA	DRAWER SIDE	LATERAL CAJÓN	MDP	350	88	12	4
18	10541	CONTRA FUNDO	Against the background	CONTRA FONDO	MDP	624	88	12	2
19	10542	FUNDO DE GAVETA	DRAWER BACKGROUND	FONDO DE CAJÓN	HDF	648	355	3	2
20	10543	PORTA	DOOR	PUERTA	MDP	1965	750	15	2
21	10544	FUNDO	BOTTOM	FONDO	HDF	2016	742	3	2

Data de lançamento: 02/08/2018
Versão:

Data de Atualização: 26/09/2018
Revisão: -

Vista Superior / Upper View / Vista Superior

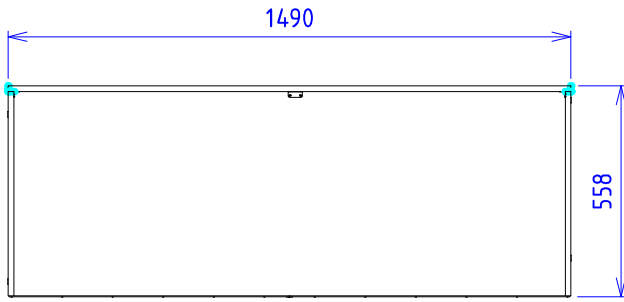

Vista Superior / Upper View / Vista Superior

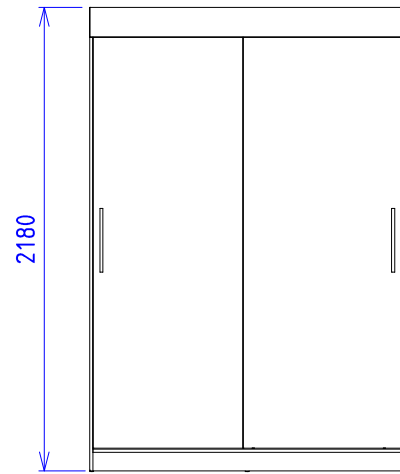

Dimensão do Produto: (LxAxP) 1490x2180x558

INSTRUÇÃO MONTAGEM PRODUTO

Intructions to Assembly / Instrucciones de montaje



Separate the parts and accessories in an organized way.
Separate parts and accessories in way organized
Separe las piezas y accesorios de manera organizada



Cover the floor with the cardboard.
Cover the floor with the cardboard
Cubra el suelo con la embalaje de cartón



It is necessary one person to assemble the product.
It is necessary one person to assembly
Es necesario una persona para ensamblar

The product must be assembled by a professional.
The product must be assembly by a professional
El producto debe ser ensamblado por un profesional calificado

Tools necessary (not provided)
Not include tools / No herramientas



CUIDADO PARA CONSERVAÇÃO E LIMPEZA DO MÓVEL

Care to conservation and clean / Cuidados de limpieza



Maximum weight load refers to objects distributed uniformly over the entire contact area of the workpiece.
Conjunto de carga máxima de peso se refiere a objetos distribuidos uniformemente sobre toda el área de contacto de la pieza de trabajo.



Do not wet the mobile and do not expose in a wet place.
Do not wet the mobile and do not expose in a wet place
No moje el producto y no exponer en un lugar húmedo



Do not expose the mobile near heat sources.
Do not expose the mobile near heat sources
no exponga cercano de fuentes de calor



Do not use abrasive products.
Do not use abrasive products.
No utilice productos abrasivos.



Clean with dry cloth.
Clean with dry cloth
Limpieza con un paño limpio y seco

LISTA DE ACESSÓRIOS E FERRAGEM / ACCESSORIES AND HARDWARE / ACCESORIOS Y EQUIPOS



A PARAFUSO 4.5 X 32 CHATA PHILIPS 8 UNID
Screw 4.5 X 45 / Tornillo 4.5 X 45

B PARAFUSO 3.5 X 12 CHATA PHILIPS 86 UNID
Screw 3.5 X 12 / Tornillo 3.5 X 12

C PARAFUSO 3 X 12 PH 36 UNID
Screw 3.0 X 12 / Tornillo 3.0 X 12

D PARAFUSO 3.5 X 25 PHILIPS 8 UNID
Screw 3.5 X 25 / Tornillo 3.5 X 25

E CAVILHA MADEIRA 6 X 30 MM 52 UNID
Wood Bolts / Cuchillo de madera

F PREGO 10X10 116 UNID
Nail / Clavo

G PARAFUSO MINIFIX ZAMAC 30 UNID
minifix screw / tornillo minifix

H TAMBOR MINIFIX 34 UNID
Minifix Drum / Tambor Minifix

I FIXADOR DE FUNDO 13 UNID
bottom fixative / fijador de fondo

J TAPA FURO 38 UNID
tap hole / tapa del agujero

K HASTE DUPLA MINIFIX 2 UNID
minifix double rod / valla doble minifix

L PERFIL PUX PT CORRER 300mm 2 UNID
Profile Handle / Perfil Puxador

M SUPORTE OBLONGO 04 UNID
oblong support / soporte oblongo

N CORREDIÇA TElescÓPICA 300mm 2 UNID
telescopic slide / corredera telescópica

O KIT RODÍZIO 2 UNID
carousel kit / kit de ruedas

P CABIDEIRO 712mm 2 UNID
coat rack / estante

Q PERFIL DE ALUMINIO 1456mm 01 UNID
aluminum profile / perfil de aluminio

R PERFIL "E" PVC 1456mm 01 UNID
PVC profile / perfil de PVC

S PARAFUSO 4,0 X 14 PHILIPS 4 UNID
Screw 4.0 X 14 / Tornillo 4.0 X 14

T CANTONEIRA 4 FURO 14 UNID
4-hole angle bracket / cantón 4 agujero

U SAPATA "L" 5 UNID
shoe "L" / zapato "L"

V PERFIL ANTI EMPENO 1965mm 02 UNID
anti-warping profile / perfil anti empeno

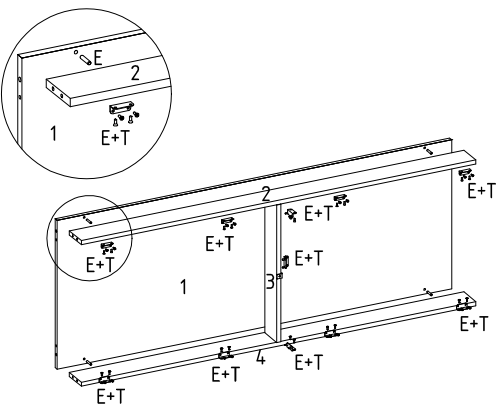
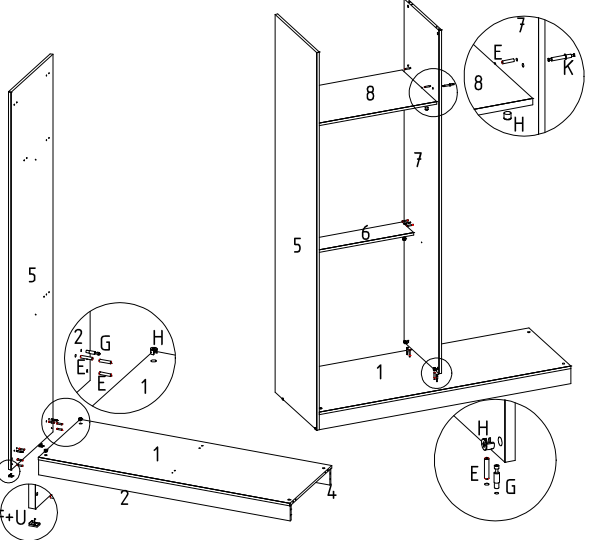
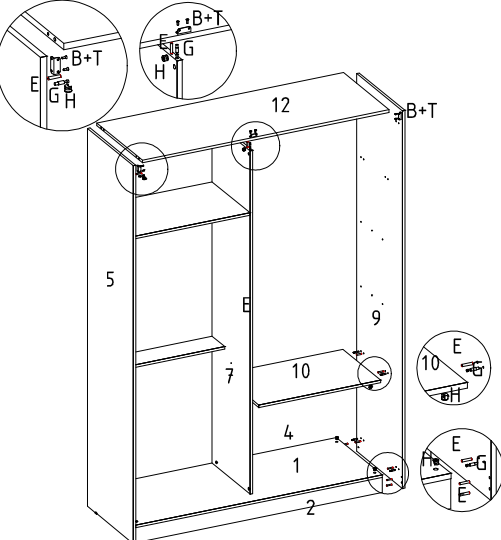
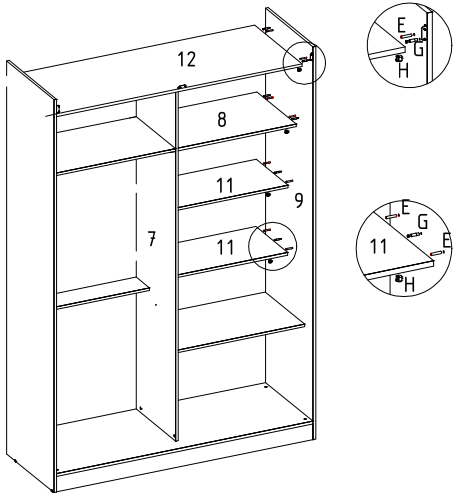
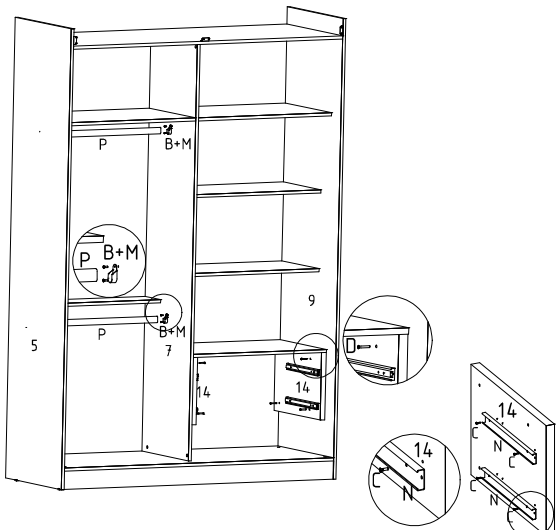
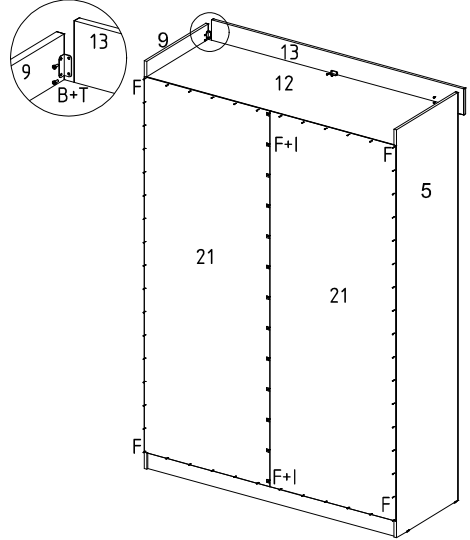
<p>01° PASSO</p> <p>01° STEP</p> <p>01° PASO</p> <p>B</p> <p>E</p> <p>T</p> <p>-</p> <p>-</p> <p>-</p>	<p>Fixar as peças 2,3 e 4 na peça 1</p> <p>Secure parts 2,3 and 4 in part 1</p> <p>Fijar las piezas 2,3 y 4 en la pieza 1</p> 	<p>02° PASSO</p> <p>02° STEP</p> <p>02° PASO</p> <p>E</p> <p>F</p> <p>G</p> <p>H</p> <p>U</p> <p>-</p> <p>-</p> <p>-</p>	<p>Fixar a peça 5 nas peças 1,2,4, fixar as peças 6,7 e 8 nas peças 1 e 5</p> <p>Fasten part 5 on parts 1,2,4, fix parts 6, 7 and 8 on parts 1 and 5</p> <p>Fijar la pieza 5 en las piezas 1,2,4, fijar las piezas 6,7 y 8 en las piezas 1 y 5</p> 
<p>03° PASSO</p> <p>03° STEP</p> <p>03° PASO</p> <p>E</p> <p>G</p> <p>H</p> <p>K</p> <p>T</p> <p>B</p>	<p>Fixar a peça 12 nas peças 5 e 7,fixar as peças 9 e 10 nas peças 1,2,4 e 7</p> <p>Fasten piece 12 on parts 5 and 7, secure pieces 9 and 10 on parts 1,2,4 and 7</p> <p>Fijar la pieza 12 en las piezas 5 y 7, fijar las piezas 9 y 10 en las piezas 1,2,4 y 7</p> 	<p>04° PASSO</p> <p>04° STEP</p> <p>04° PASO</p> <p>E</p> <p>G</p> <p>H</p> <p>-</p> <p>-</p> <p>-</p>	<p>Fixar as peças 8,11 e 12 nas peças 7 e 9</p> <p>Attach parts 8, 11 and 12 to parts 7 and 9</p> <p>Fijar las piezas 8,11 y 12 en las piezas 7 y 9</p> 
<p>05° PASSO</p> <p>05° STEP</p> <p>05° PASO</p> <p>B</p> <p>C</p> <p>D</p> <p>M</p> <p>N</p> <p>P</p>	<p>Fixar as peças 14 e 15 nas peças 7 e 9, fixar os acessórios M nas peças 5 e 7</p> <p>Fasten parts 14 and 15 on parts 7 and 9, attach accessories M on parts 5 and 7</p> <p>Fijar las piezas 14 y 15 en las piezas 7 y 9, fijar los accesorios M en las piezas 5 y 7</p> 	<p>06° PASSO</p> <p>06° STEP</p> <p>06° PASO</p> <p>B</p> <p>F</p> <p>I</p> <p>T</p> <p>-</p> <p>-</p> <p>-</p>	<p>Fixar as peças 21 utilizando os acessórios F e I,fixar a peça 13 nas peças 5,9 e 12</p> <p>Secure the parts 21 using the fittings F e I, fix the part 13 on the parts 5, 9 and 12</p> <p>Fijar las piezas 21 utilizando los accesorios F e I, fijar la pieza 13 en las piezas 5,9 y 12</p> 

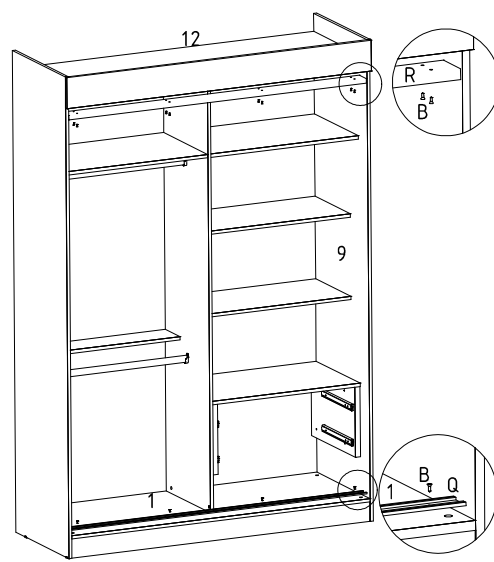
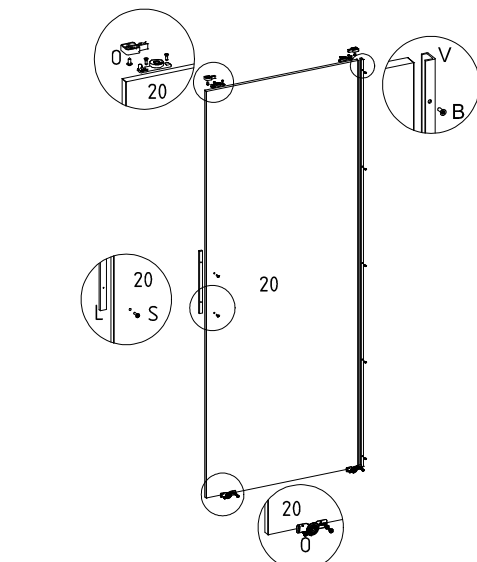
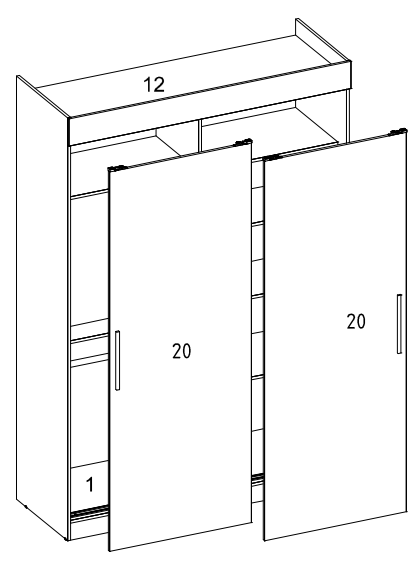
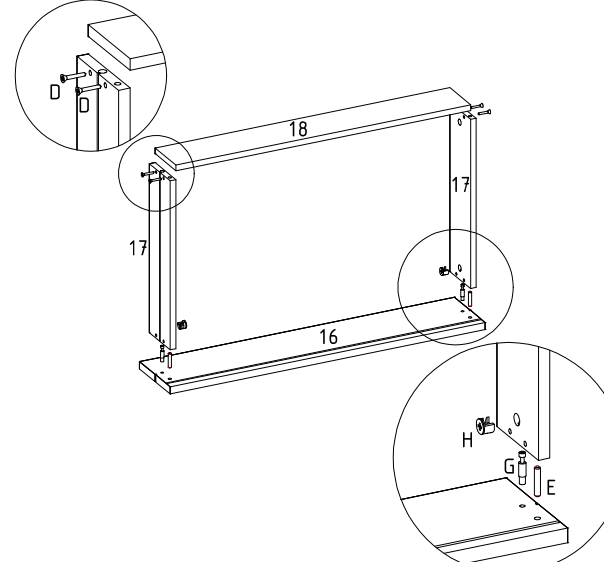
<p>07° PASSO</p> <p>07° STEP</p> <p>07° PASO</p> <p>B</p> <p>R</p> <p>Q</p>	<p>Fixar os acessórios Q na peça 1,fixar o acessório R na peça 12</p> <p>Fix the accessories Q on part 1, fix the accessory R on the part 12</p> <p>Fijar los accesorios Q en la pieza 1, fijar el accesorio R en la pieza 12</p> 	<p>08° PASSO</p> <p>08° STEP</p> <p>08° PASO</p> <p>L</p> <p>O</p> <p>S</p> <p>V</p> <p>B</p> 
<p>09° PASSO</p> <p>09° STEP</p> <p>09° PASO</p>	<p>Encaixar as peças 20 nas peças 1 e 12</p> <p>Fasten parts 20 to parts 1 and 12</p> <p>Encaje las piezas 20 en las piezas 1 y 12</p>	<p>10° PASSO</p> <p>10° STEP</p> <p>10° PASO</p>
<p>-</p>		<p>D</p> <p>E</p> <p>G</p> <p>H</p> 
<p>11° PASSO</p> <p>11° STEP</p> <p>11° PASO</p>	<p>Fixar a peça 19 nas peças 17 e 18,fixar o acessório N nas peças 17</p> <p>Fasten piece 19 on parts 17 and 18, attach accessory N on parts 17</p> <p>Fijar la pieza 19 en las piezas 17 y 18, fijar el accesorio N en las piezas 17</p>	<p>12° PASSO</p> <p>12° STEP</p> <p>12° PASO</p>
<p>C</p> <p>F</p> <p>N</p>	