

Armário 3 Portas

Armario de 3 Puertas

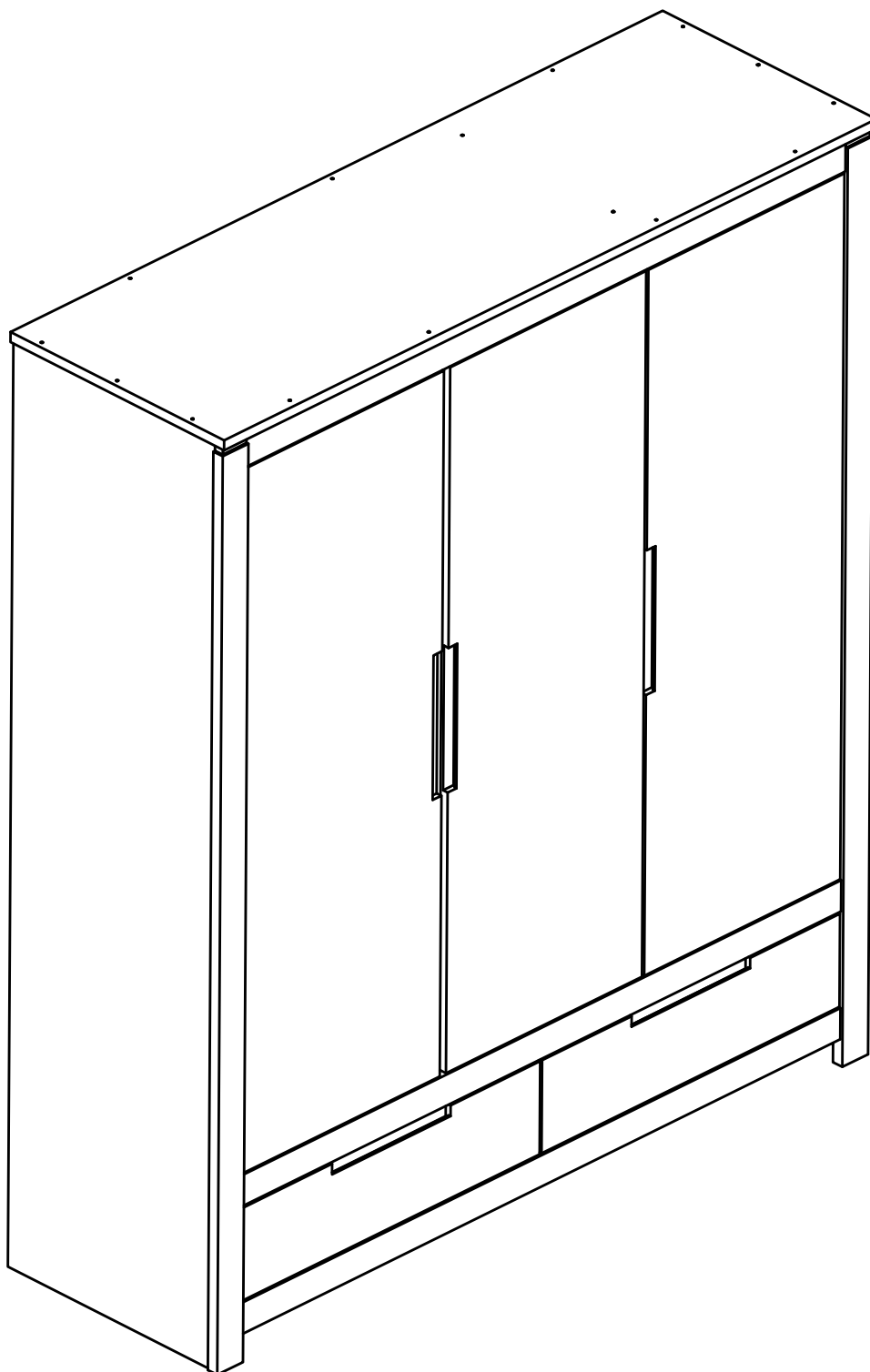

Ferramentas necessárias

Herramientas necesarias



Identificação das Peças

Identificación de las piezas

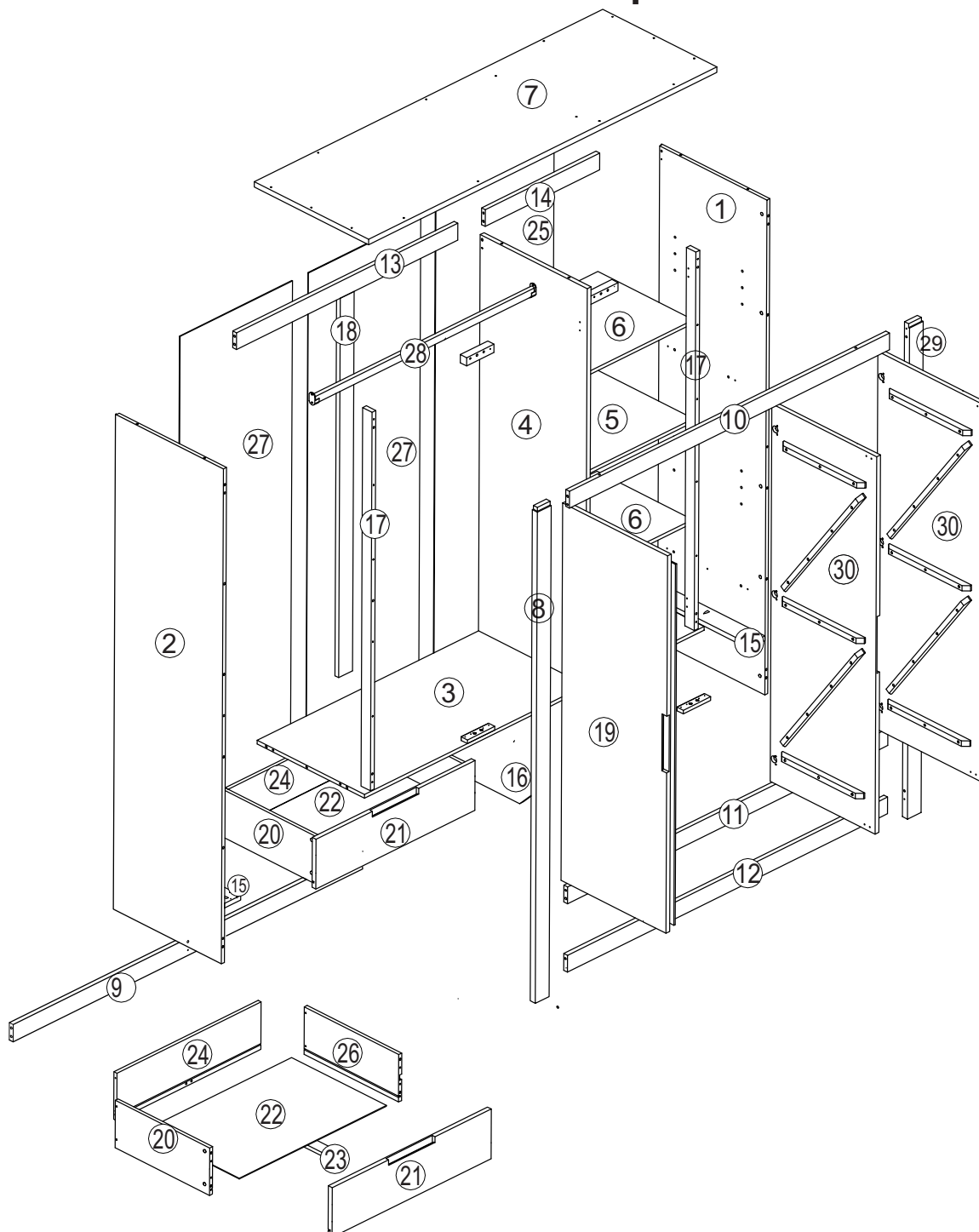

Identificação das peças

Identificación de las piezas

- 1- Lateral direita/ Lateral derecha (1x) - 1920x515x14
- 2- Lateral esquerda/ Lateral izquierda (1x) - 1920x515x14
- 3- Prateleira fixa maior/ Estanteria fijo grande (1x) - 1610x511x14
- 4- Divisória/ Divisoria (1x) - 1537x510x18
- 5- Prateleira fixa menor/ Estanteria fijo menor (1x) - 543x446x14
- 6- Prateleira móvel/ Estanteria móvil (2x) - 541x446x14
- 7- Tampo/ Tapo (1x) - 1652x544x21
- 8- Travessa lateral esquerda/ Travesaño lateral izquierdo (1x) - 1920x65x21
- 9- Montante traseiro inferior/ Montante trasero inferior (1x) - 1610x65x18
- 10- Travessa frontal superior/ Travesaño frontal superior (1x) - 1518x65x18
- 11- Travessa frontal central/ Travesaño frontal central (1x) - 1518x65x18
- 12- Travessa frontal inferior/ Travesaño frontal inferior (1x) - 1518x65x18
- 13- Montante traseiro sup. maior/ Montante trasero sup maior (1x) - 1050x65x18
- 14- Montante Traseiro superior / Montante trasero superior (1x) - 543x65x18
- 15- Corrediça/ Corrediza (2x) - 450x76x18
- 16- Divisória inferior/ Divisoria Inferior (1x) - 368x511x18
- 17- Travessa da Dobradiça/ Travesaño Bisagra (2x) - 1468x44x18
- 18- Montante traseiro/ Montante trasero (1x) - 1472x65x18
- 19- Porta esquerda Montada/ Puerta izquierda Montado (1x) - 1464x517x43
- 20- Lateral Esquerda da Gaveta/ Lateral izquierda del cajón (1x) - 450x184x14
- 21- Frente Gaveta/ Frente del cajón (2x) - 754x193x18
- 22- Fundo gaveta MDF/ Fondo del cajón MDF (2x) - 698x451x3
- 23- Calço da Gaveta/ Soporte del cajón (2x) - 437x44x14
- 24- Costa Gaveta/ Costa de cajón (2x) - 684x184x14
- 25- Fundo MDF / Fondo MDF (1x) - 1865x560x3
- 26- Lateral direita da gaveta/ Lateral derecha del cajón (2x) - 450x184x14
- 27- Fundo menor MDF/ Fondo menor MDF (2x) - 865x533x3
- 28- Sarrafo Cabide/ Soporte del perchero (1x) - 1041x35x16
- 29- Travessa Lateral direita/ Travesaño lateral derecho (1x) - 1920x65x21
- 30- Porta Direita montada/ Puerta Derecha Montado (2x) - 1464x496x43

Identificação das ferragens

Identificación de las Herramientas

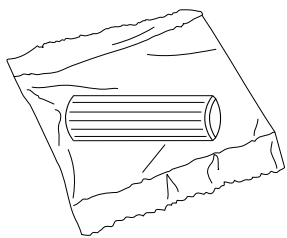

A - Cavilha 8x30 (64x)
A - Tarugo 8x30 (64x)

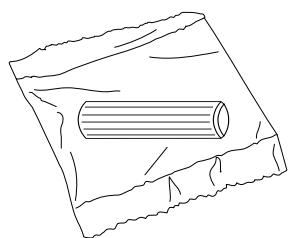

B - Cavilha 6x30 (16x)
B - Tarugo 6x30 (16x)

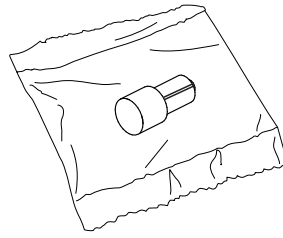

C - Suporte plástico (8x)
C - Soporte plástico (8x)

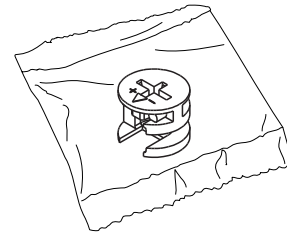

D - Tambor minifix (48x)
D - Cilindro minifix (48x)

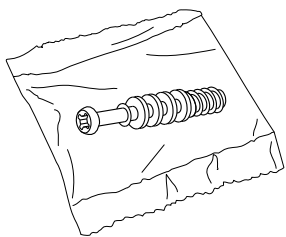

E - Parafuso minifix (48x)
E - Tornillo minifix (48x)

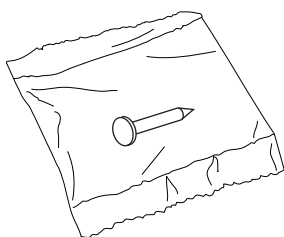

F - Prego (80x)
F - Clavo (80x)

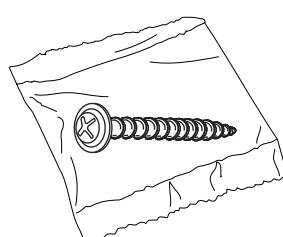

G - Parafuso 3,5x30 (12x)
G - Tornillo 3,5x30 (12x)

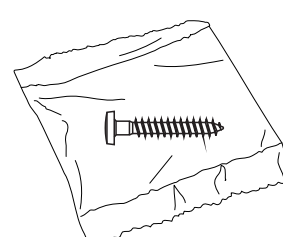

H - Parafuso 3,5x14 (48x)
H - Tornillo 3,5x14 (48x)

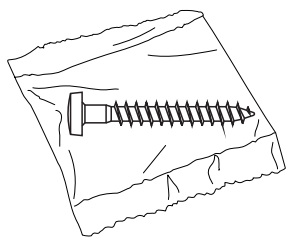

I - Parafuso 5x50 (12x)
I - Tornillo 5x50 (12x)

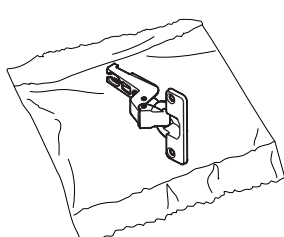

J - Dobradiça (9x)
J - Bisagra (9x)

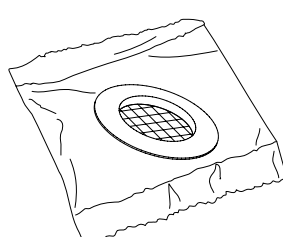

K - Tampa para ventilação (3x)
K - Tapa para ventilación (3x)

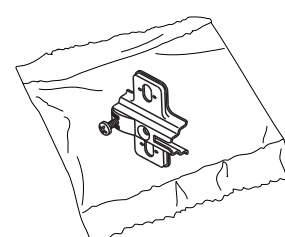

L - Calço da dobradiça (6x)
L - Soporte de la bisagra (6x)

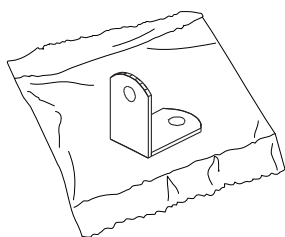

M - Chapinha L (4x)
M - Chapita L (4x)

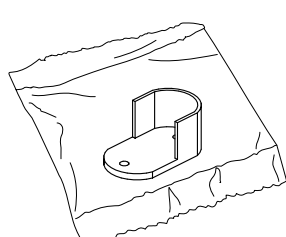

N - Suporte cabideiro (2x)
N - Soporte del perchero (2x)

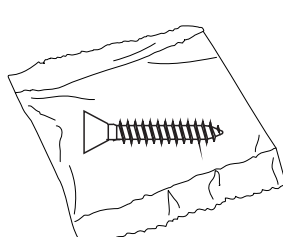

O - Parafuso 3,5x12 (14x)
O - Tornillo 3,5x12 (14x)

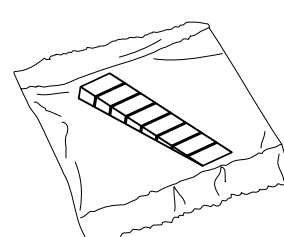

P - Calço nivelador (2x)
P - Soporte nivelador(2x)

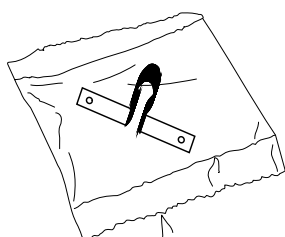

Q - Fecho macho (6x)
Q - Cierre macho (6x)

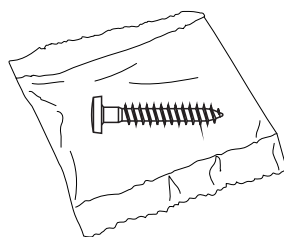

R - Parafuso 3,5x20 (6x)
R - Tornillo 3,5x20 (6x)

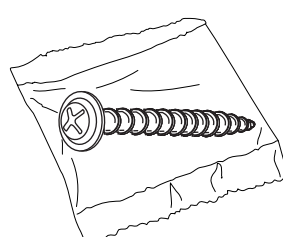

S - Parafuso 3,5x40 (26x)
S - Tornillo 3,5x40 (26x)

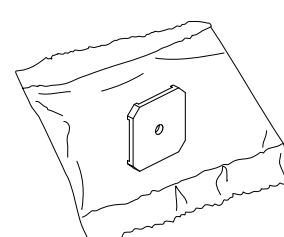

T - Fixador para fundo (15x)
T - Fijador del fondo (15x)

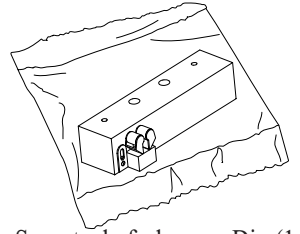
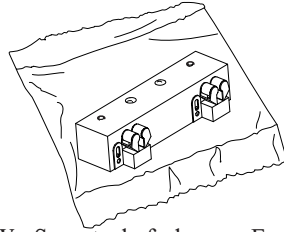
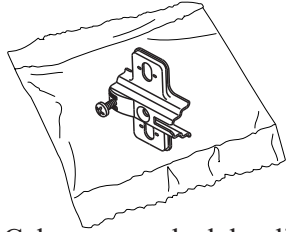
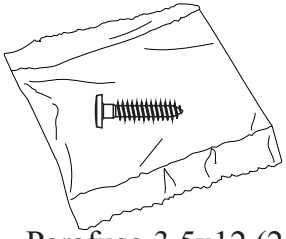

U - Parafuso 3,5x12 (24x) V - Calço menor da dobradiça (3x) W - Suporte do fecho sup. Esq. (1x) X - Suporte do fecho sup. Dir. (1x)
 U - Tornillo 3,5x12 (24x) V - Soporte menor de la bisagra (3x) W - Soporte cierre sup. Izq. (1x) X - Soporte cierre sup. Der. (1x)

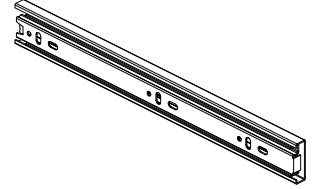
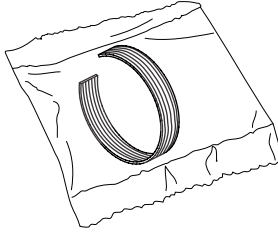
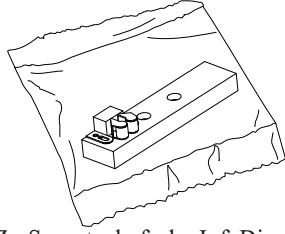
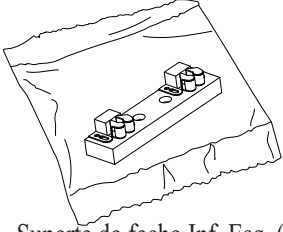

Y - Suporte do fecho Inf. Esq. (1x) Z - Suporte do fecho Inf. Dir. (1x) AA - Fita segurança (2x) AB - Corrediça (4x)
 Y - Soporte cierre Inf. Izq. (1x) Z - Soporte cierre Inf. Der. (1x) AA - Cinta de seguridad (2x) AB - Corrediza (4x)

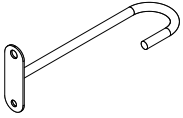

AB- Suporte gancho(1x)

PASSO 1) PRIMER PASO



A- Cavilha 8x30 (26x)
A- Tarugo 8x30 (26x)



C- Suporte plástico (4x)
C- Soporte plástico (4x)

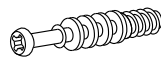

E- Parafuso minifix (12x)
E- Tornillo minifix (12x)

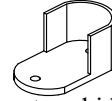

N- Suporte cabideiro (1x)
N- Soporte perchero (1x)



O- Parafuso 3,5x12 (2x)
O- Tornillo 3,5x12 (2x)

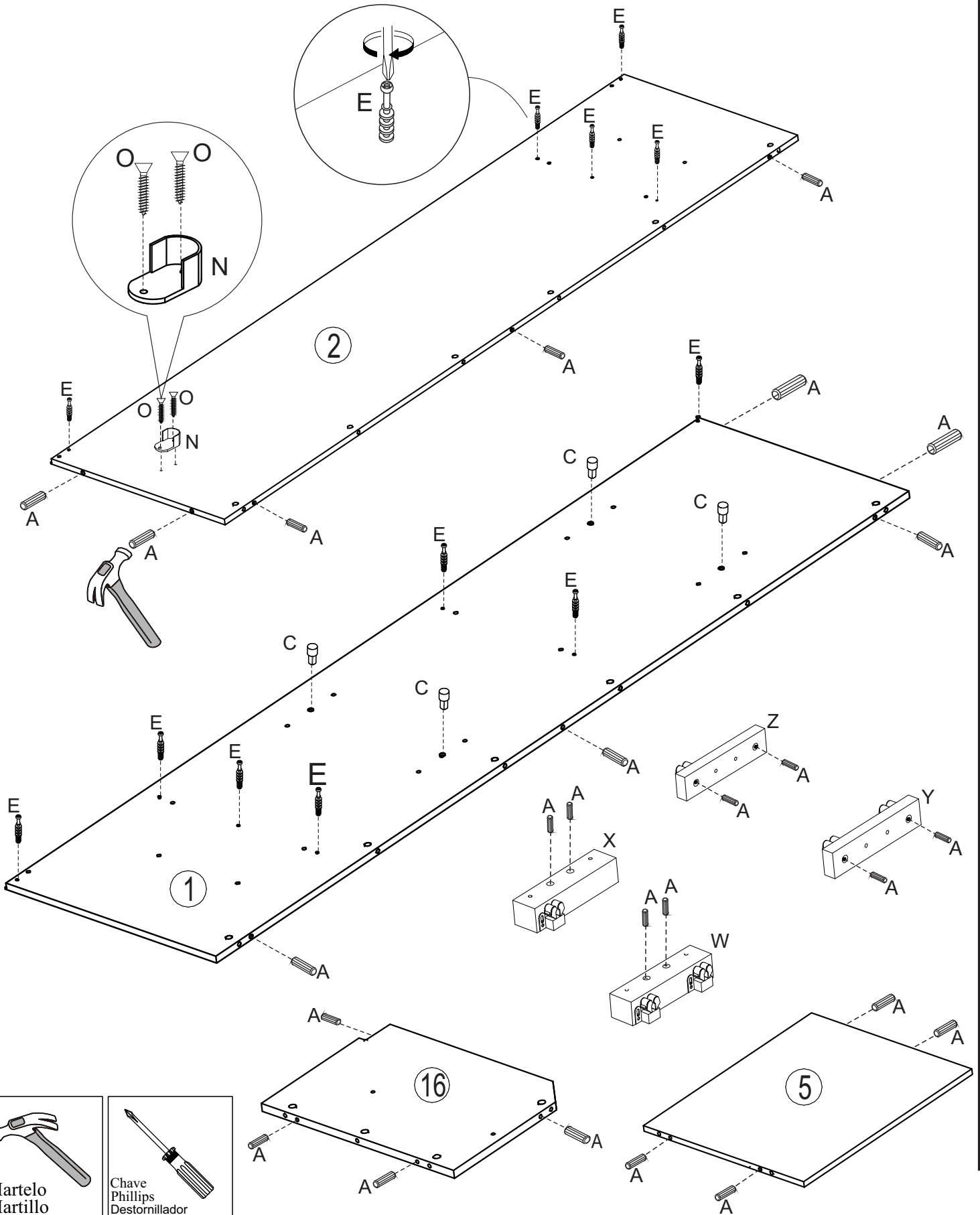

PASSO 2) SEGUNDO PASO

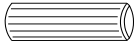

A- Cavilha 8x30 (11x)
A- Tarugo 8x30 (11x)



C- Suporte plástico (4x)
C- Soporte plástico (4x)



E- Parafuso minifix (8x)
E- Tornillo minifix (8x)



M- Chapinha L (4x)
M- Chapita L (4x)



H- Parafuso 3,5x14 (6x)
H- Tarugo 3,5x14 (6x)



O- Parafuso 3,5x12 (6x)
O- Tornillo 3,5x12 (6x)



R - Parafuso 3,5x20 (4x)
R - Tornillo 3,5x20 (4x)



Y - Suporte do fecho Inf. Esq. (1x)
Y - Soporte cierre Inf. Izq. (1x)



N- Suporte cadeiro (1x)
N- Soporte del perchero (1x)



V- Calço menor da dobradiça (3x)
V- Soporte menor de la bisagra (3x)

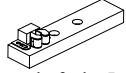

Z - Suporte do fecho Inf. Dir. (1x)
Z - Soporte cierre Inf. Der. (1x)

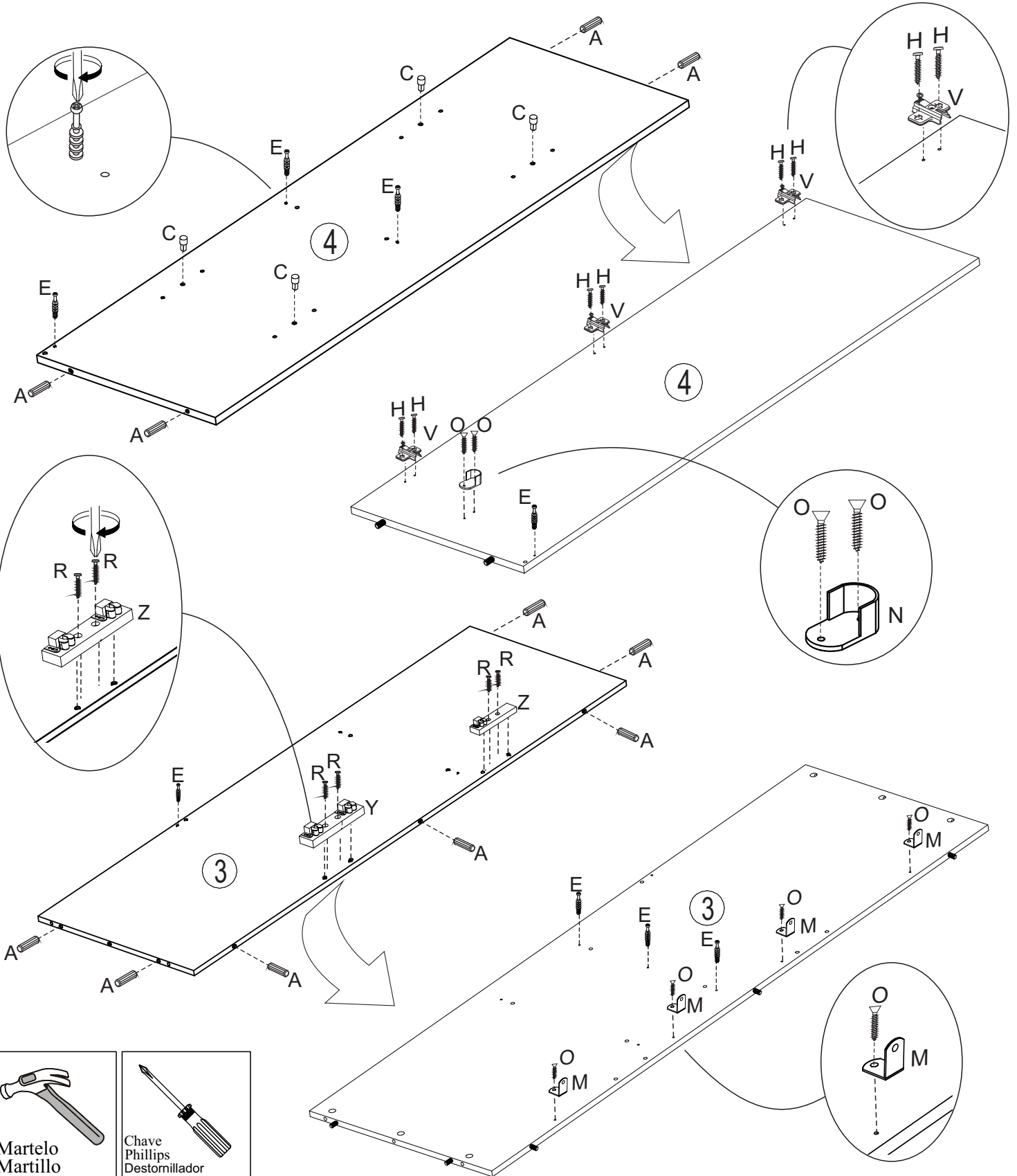

PASSO 3) TERCER PASO

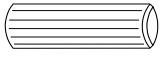

A- Cavilha 8x30 (27x)
A- Tarugo 8x30 (27x)

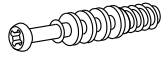

E- Parafuso minifix (20x)
E- Tornillo minifix (20x)



H- Parafuso 3,5x14 (12x)
H- Tornillo 3,5x14 (12x)

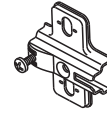

L- Calço da dobradiça (6x)
L- Soporte de la bisagra (6x)

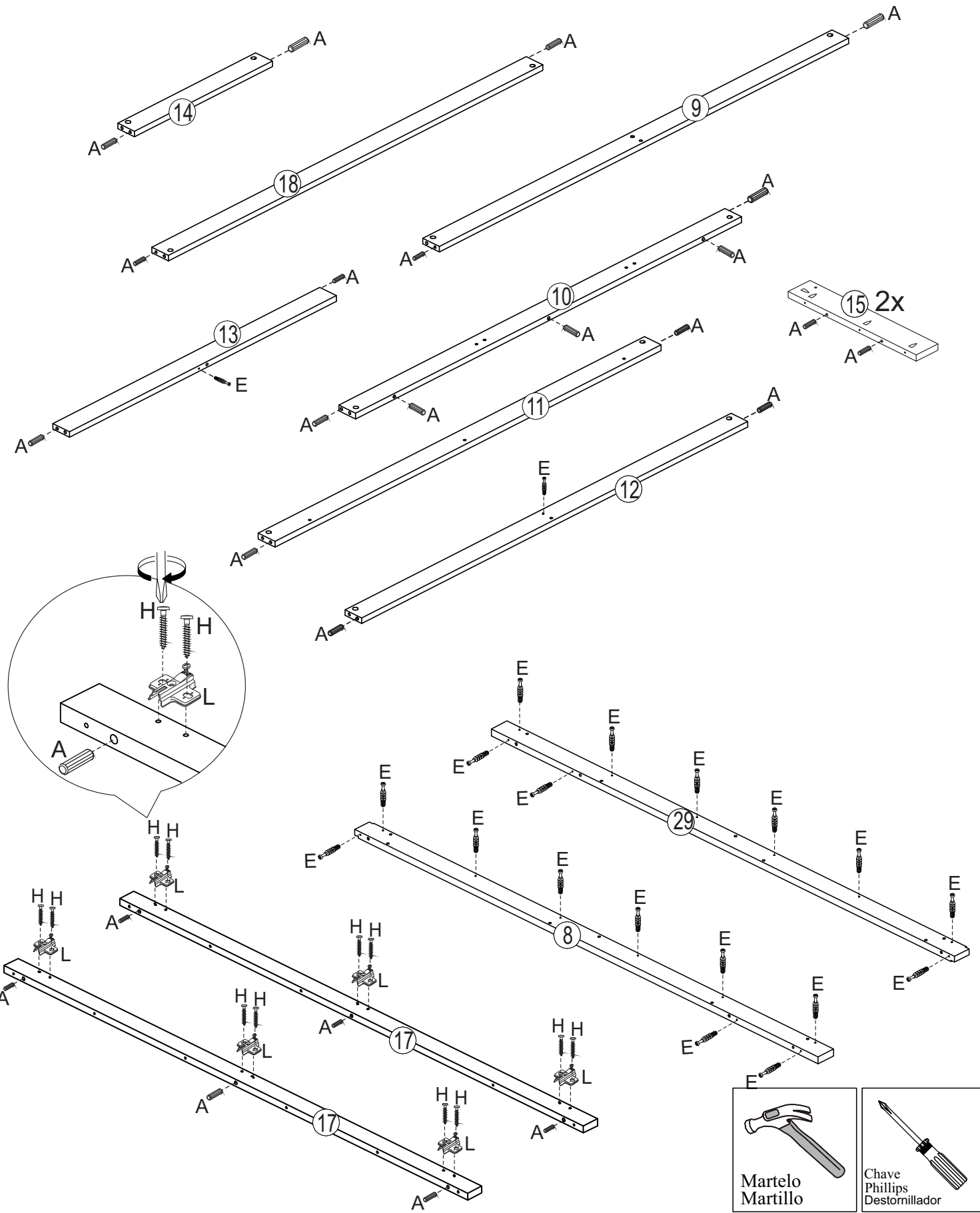

PASSO 4) CUARTO PASO



D- Tambor minifix (6x)
D- Cilindro minifix (6x)

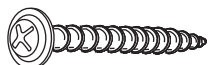

G - Parafuso 3,5x30 (4x)
G - Tornillo 3,5x30 (4x)

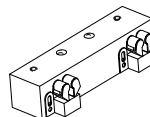

W - Suporte do fecho sup. Esq. (1x)
W - Soporte cierre sup. Izq. (1x)

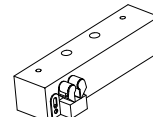

X - Suporte do fecho sup. Dir. (1x)
X - Soporte cierre sup. Der. (1x)

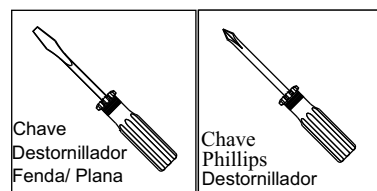
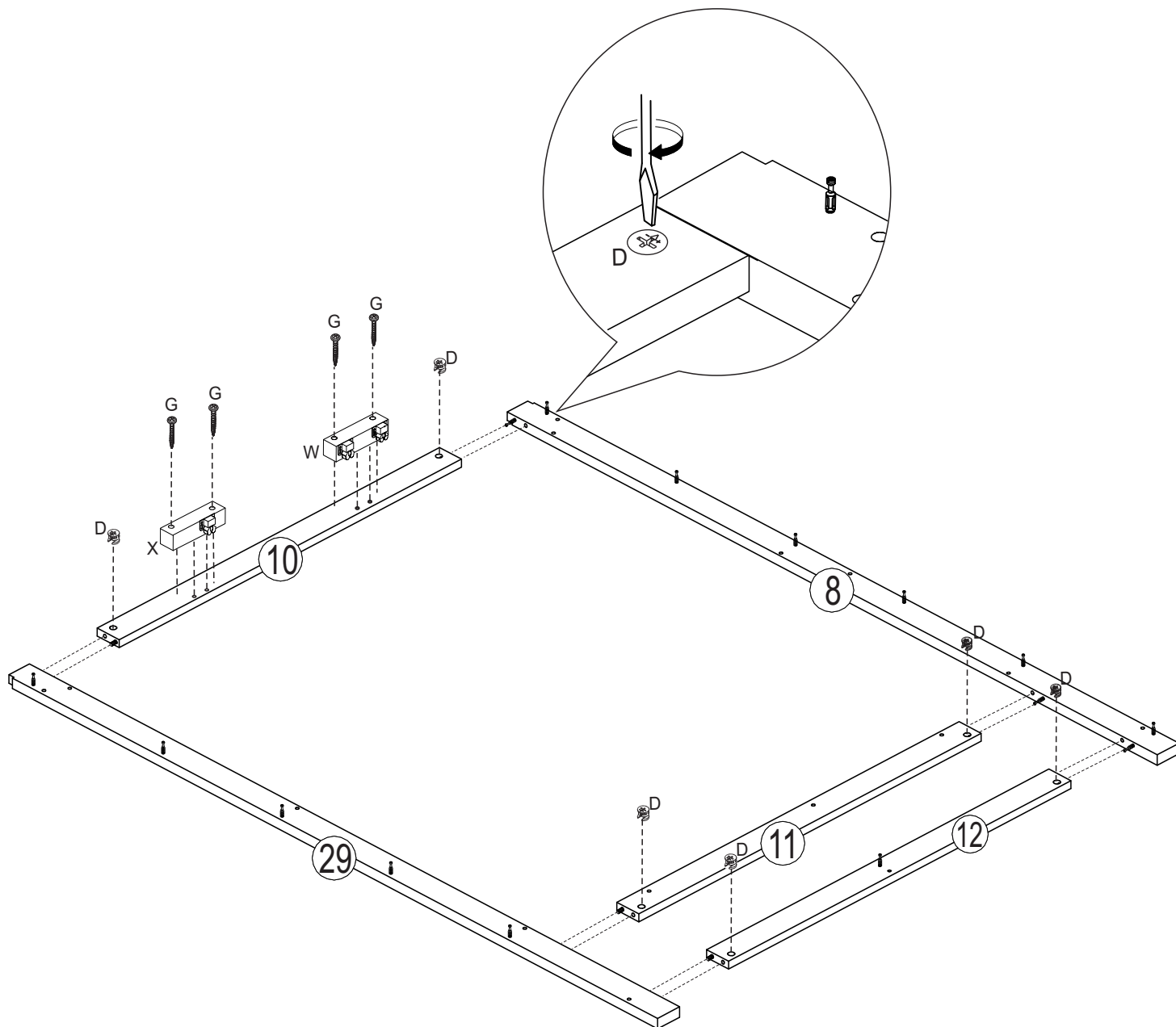

PASSO 5) QUINTO PASO



S- Parafuso 3,5x40 (2x)
S- Tornillo 3,5x40 (2x)



D- Tambor minifix (2x)
D- Cilindro minifix (2x)

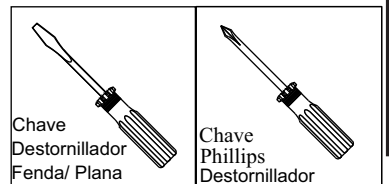
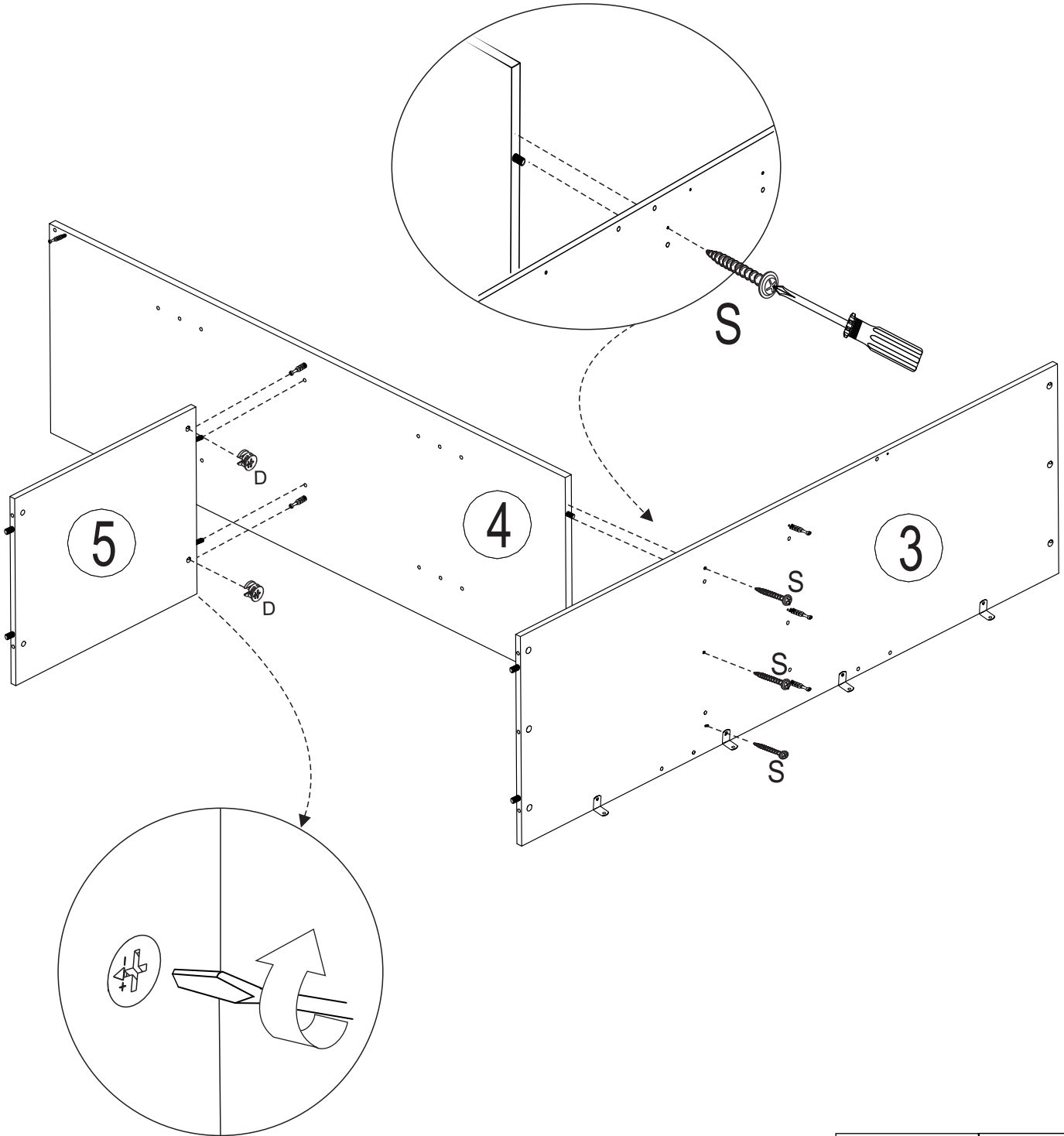

PASSO 6) SEXTO PASO

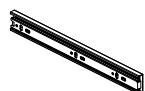

U - Parafuso 3,5x12 (6x)
U - Tornillo 3,5x12 (6x)

AB- Corrediça (2x)
AB- Corrediza (2x)

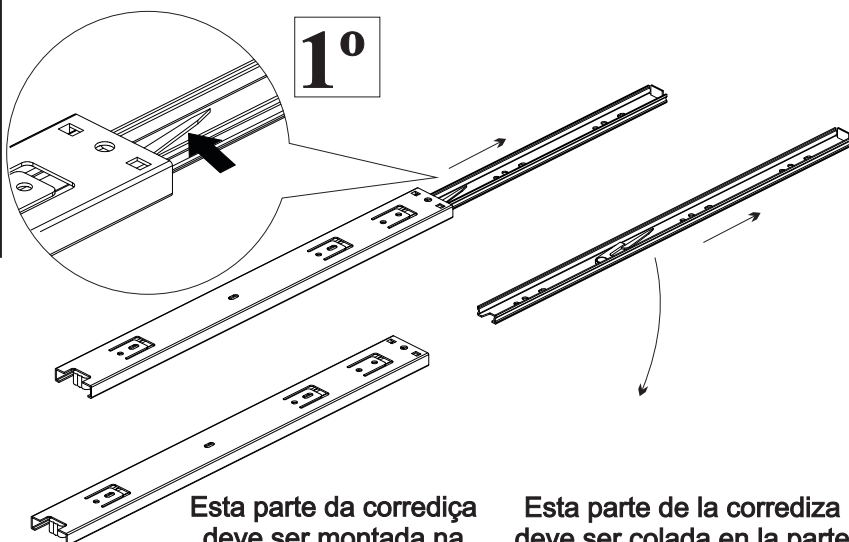

Esta parte da corrediça
deve ser montada na
lateral da gaveta

Esta parte de la corrediza
deve ser colada en la parte
lateral de los cajanes

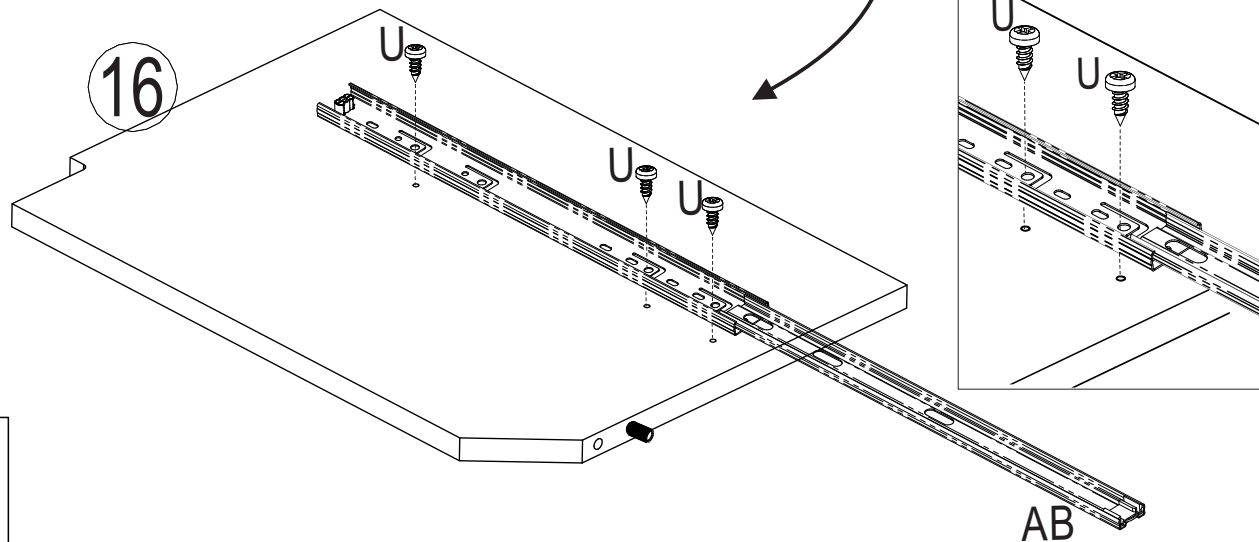
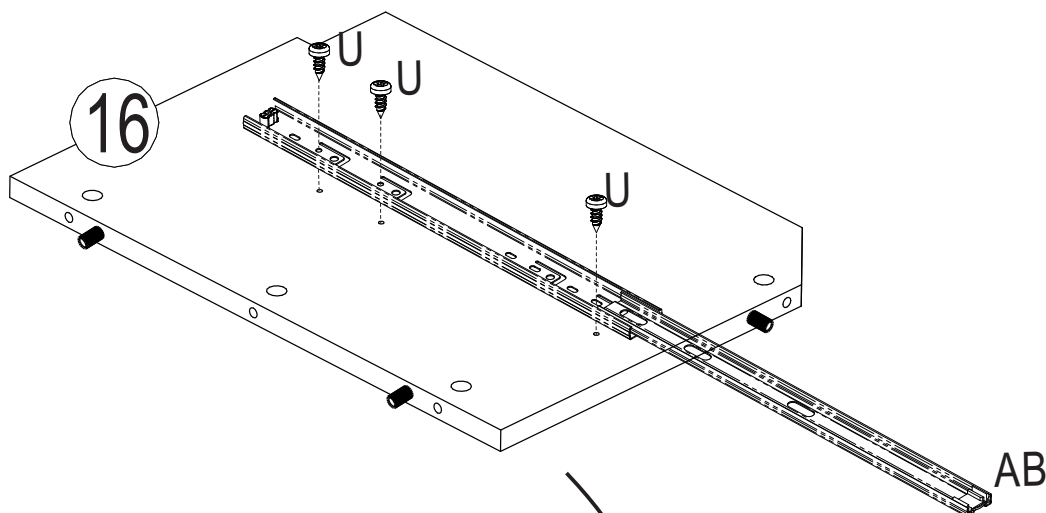
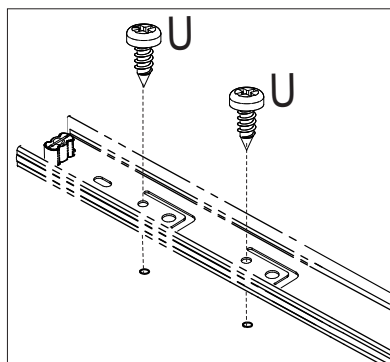

Chave
Phillips
Destornillador

PASSO 7) SÉPTIMO PASO



D- Tambor minifix (3x)
D- Cilindro minifix (3x)

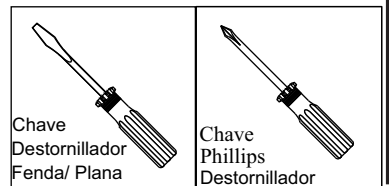
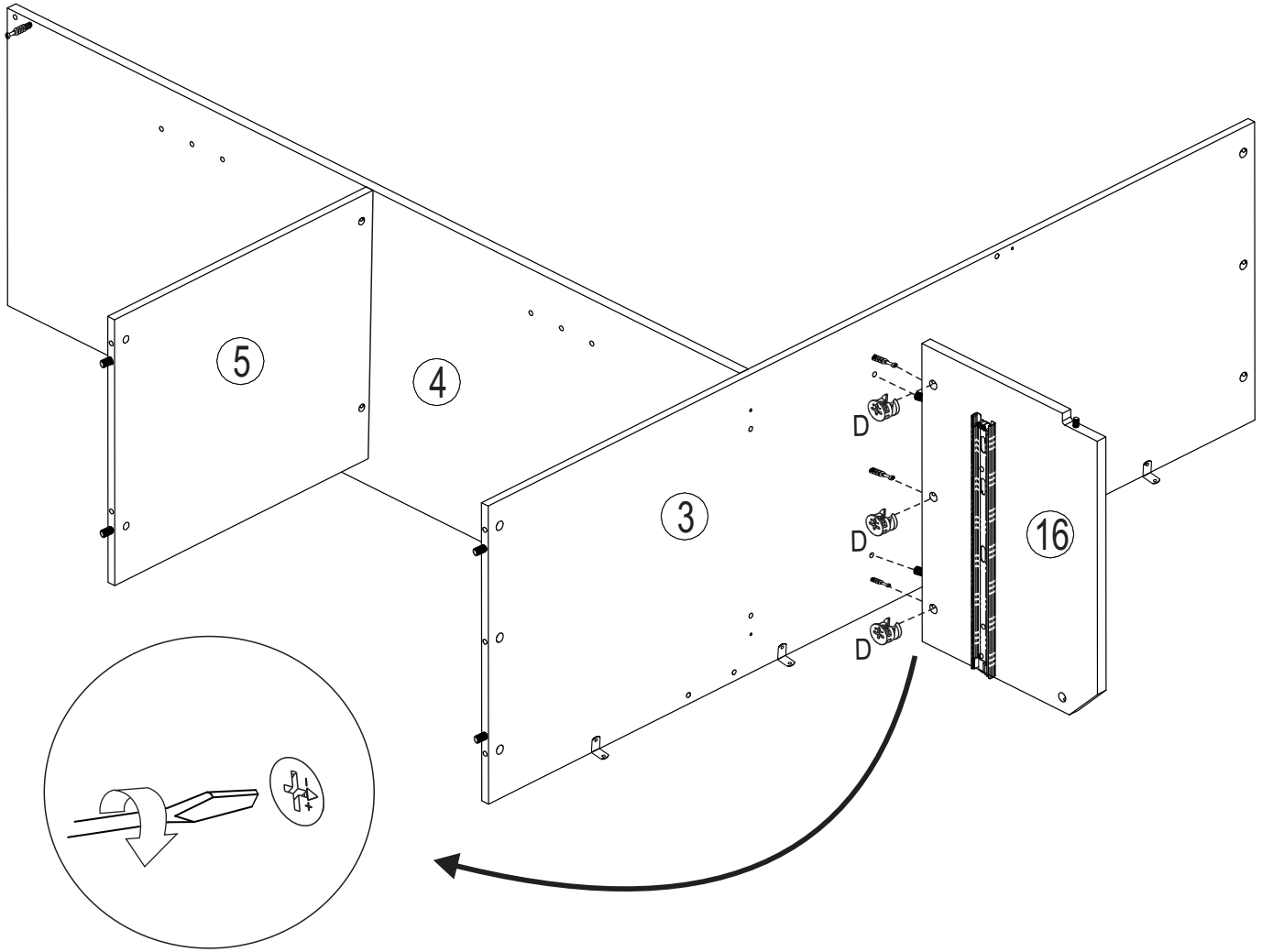

PASSO 8) OCTAVO PASO

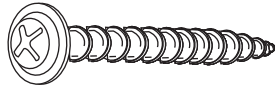
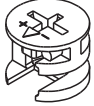

D- Tambor minifix (8x)
D- Cilindro minifix (8x)

S - Parafuso 3,5x40 (1x)
S - Tornillo 3,5x40 (1x)

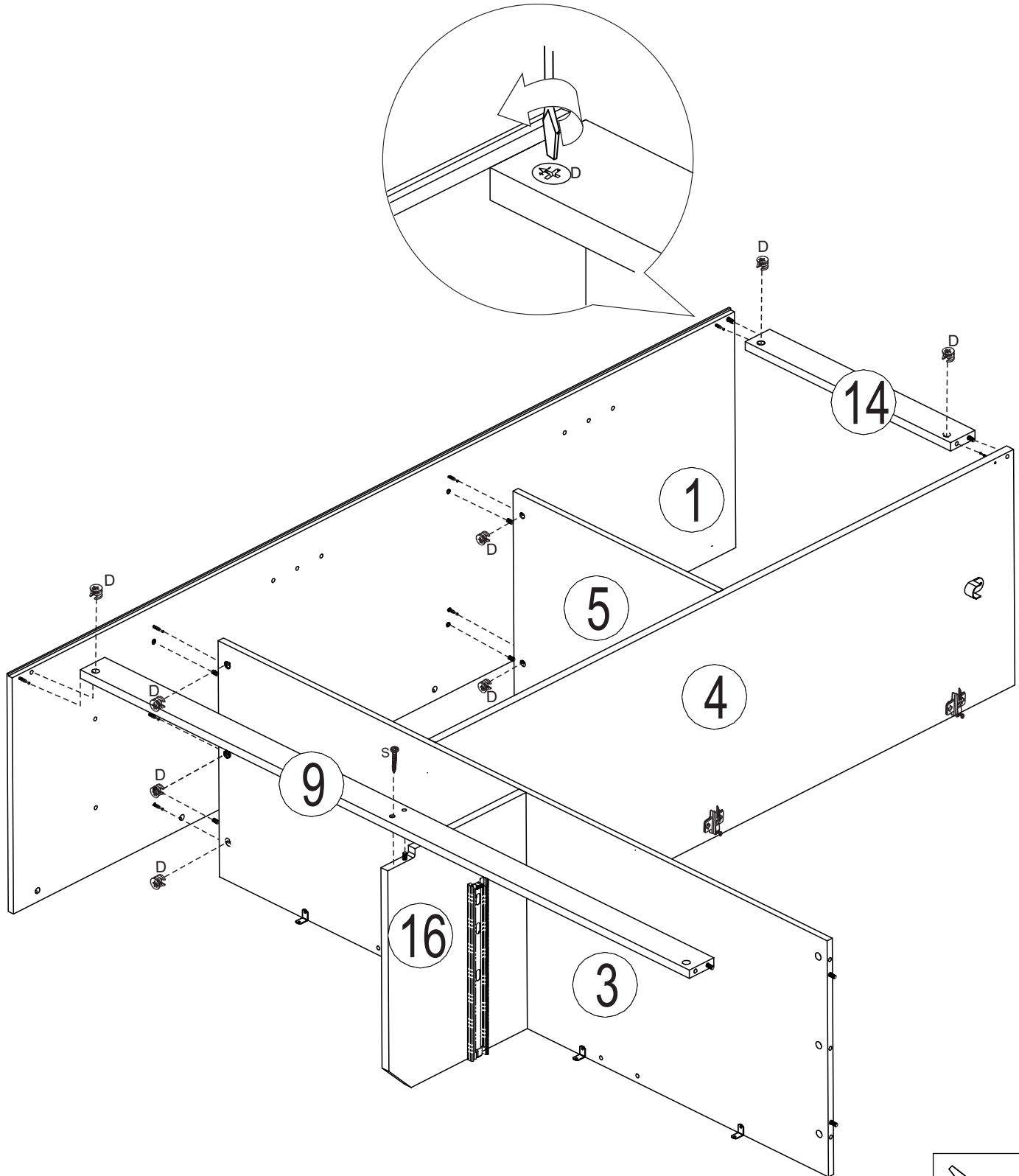

Chave
Destornillador
Fenda/ Plana

PASSO 9) NOVENO PASO



D- Tambor minifix (8x)
D- Cilindro minifix (8x)

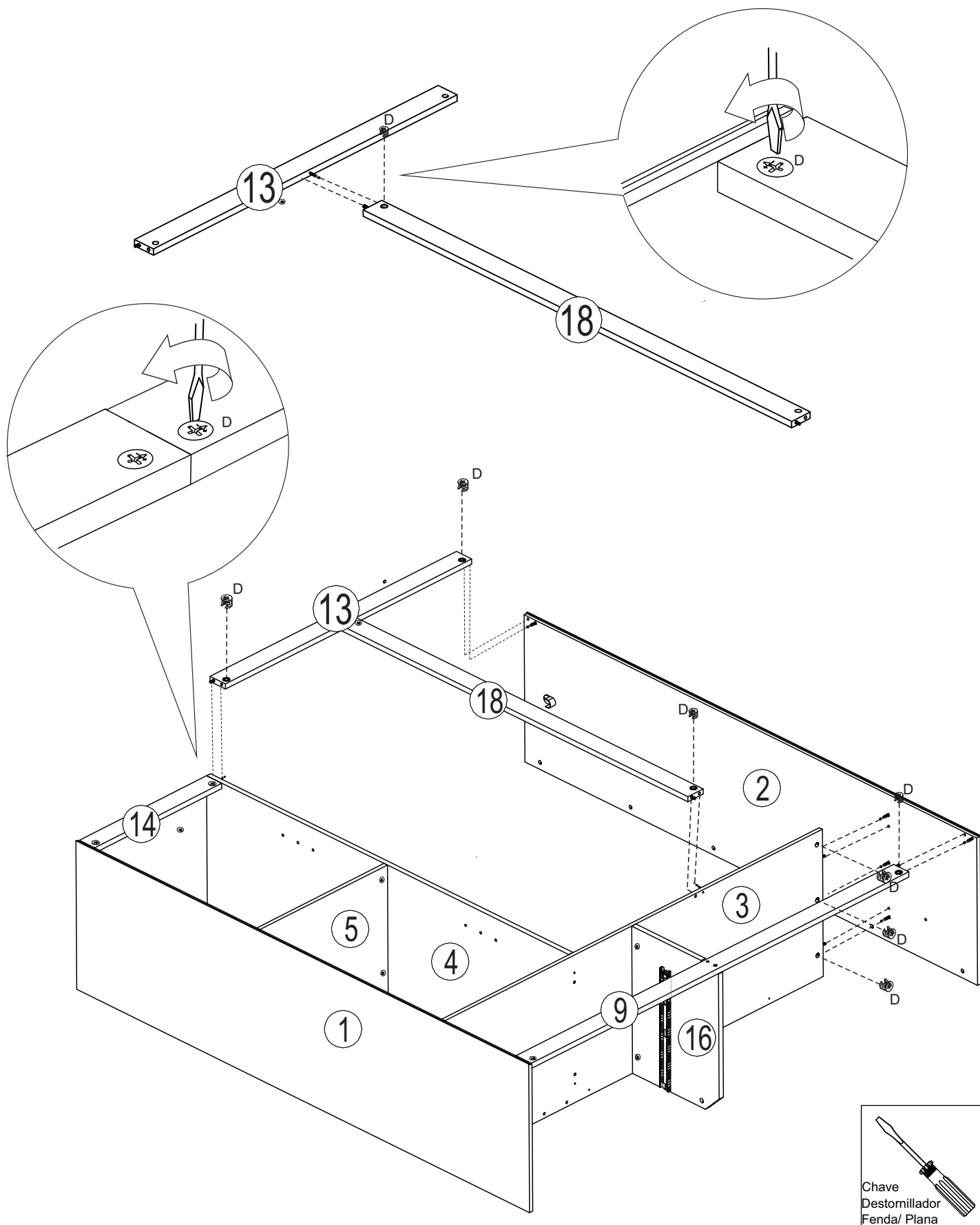

PASSO 10) DÉCIMO PASO



G- Parafuso 3,5x30 (6x)
G- Tornillo 3,5x30 (6x)

ATENÇÃO!
A furação da peça nº 15
deve estar voltada para baixo

ATENCIÓN!
La perforación de la pieza nº 15
deve estar dada vuelta para abajo

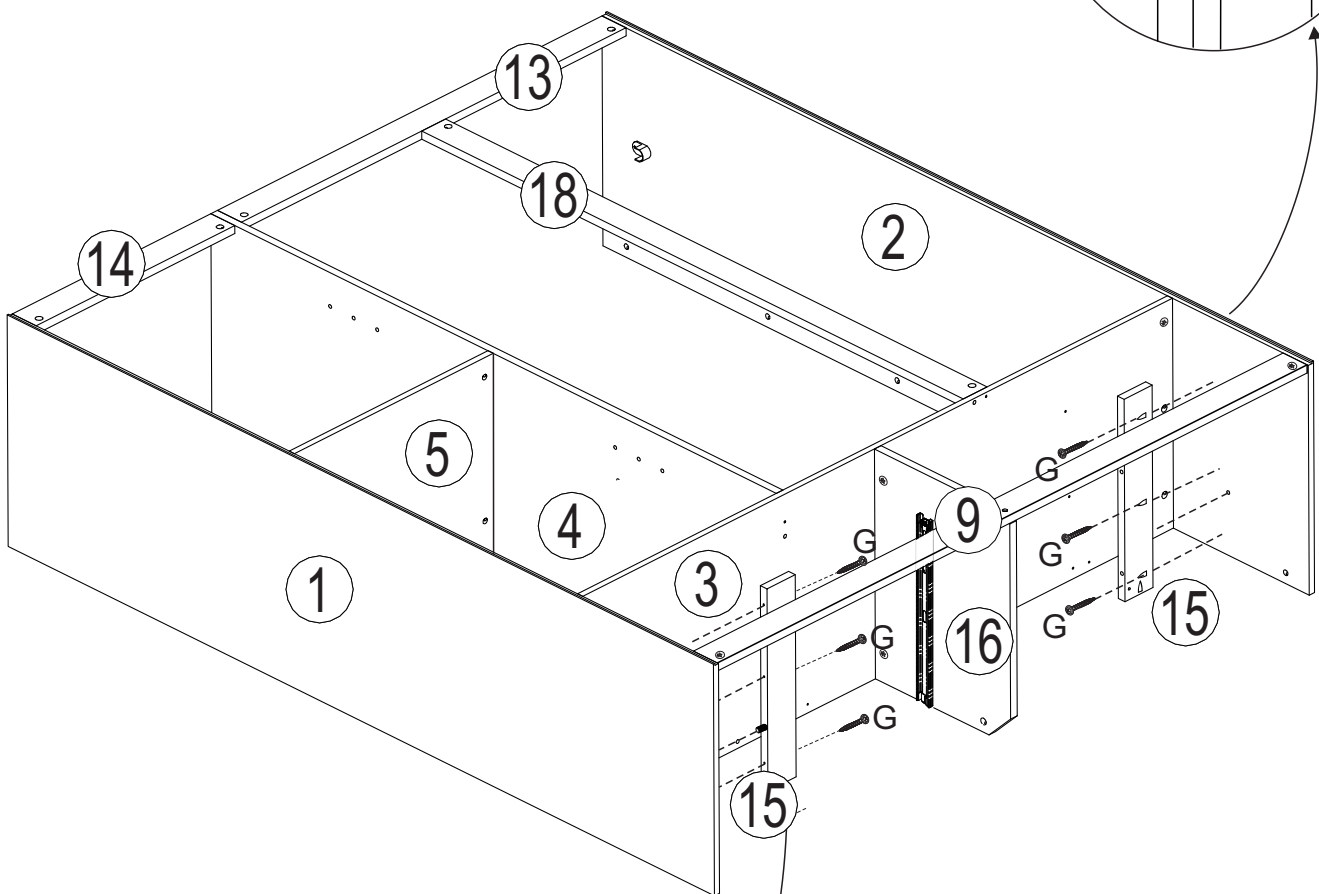
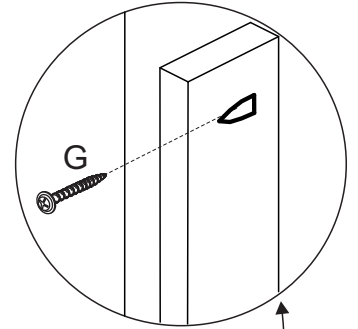

ATENÇÃO!
A furação da peça nº 15
deve estar voltada para cima

ATENCIÓN!
La perforación de la pieza nº 15
deve estar dada vuelta para arriba

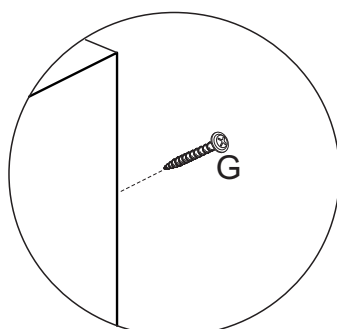

PASSO 11) DÉCIMO PRIMER PASO



U - Parafuso 3,5x12 (6x)

U - Tornillo 3,5x12 (6x)

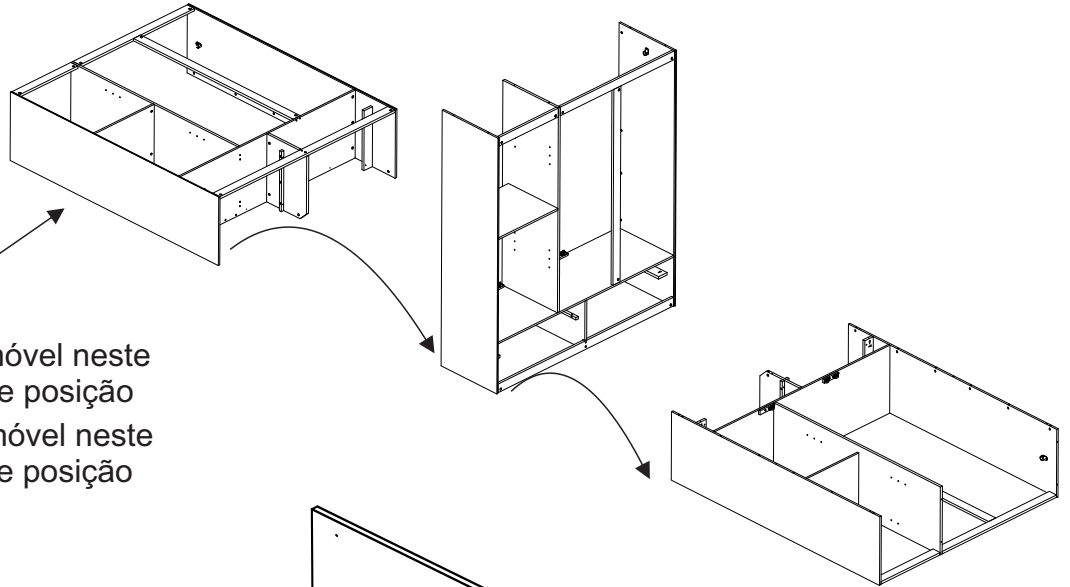

Atenção: Rotacionar o móvel neste sentido para mudá-lo de posição

Atención: Rotacionar o móvel neste sentido para mudá-lo de posición

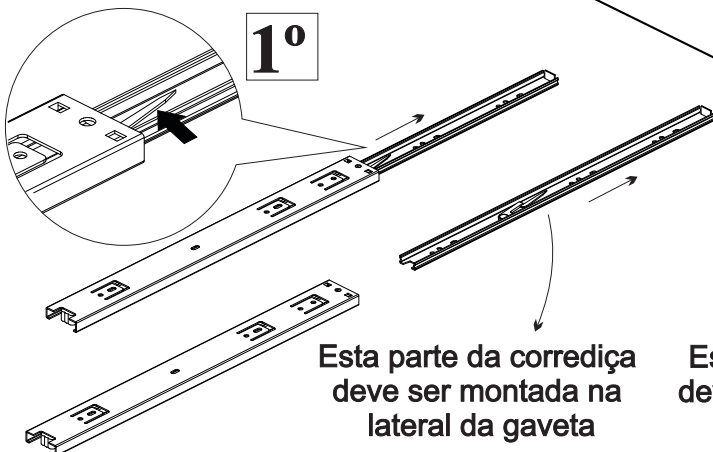
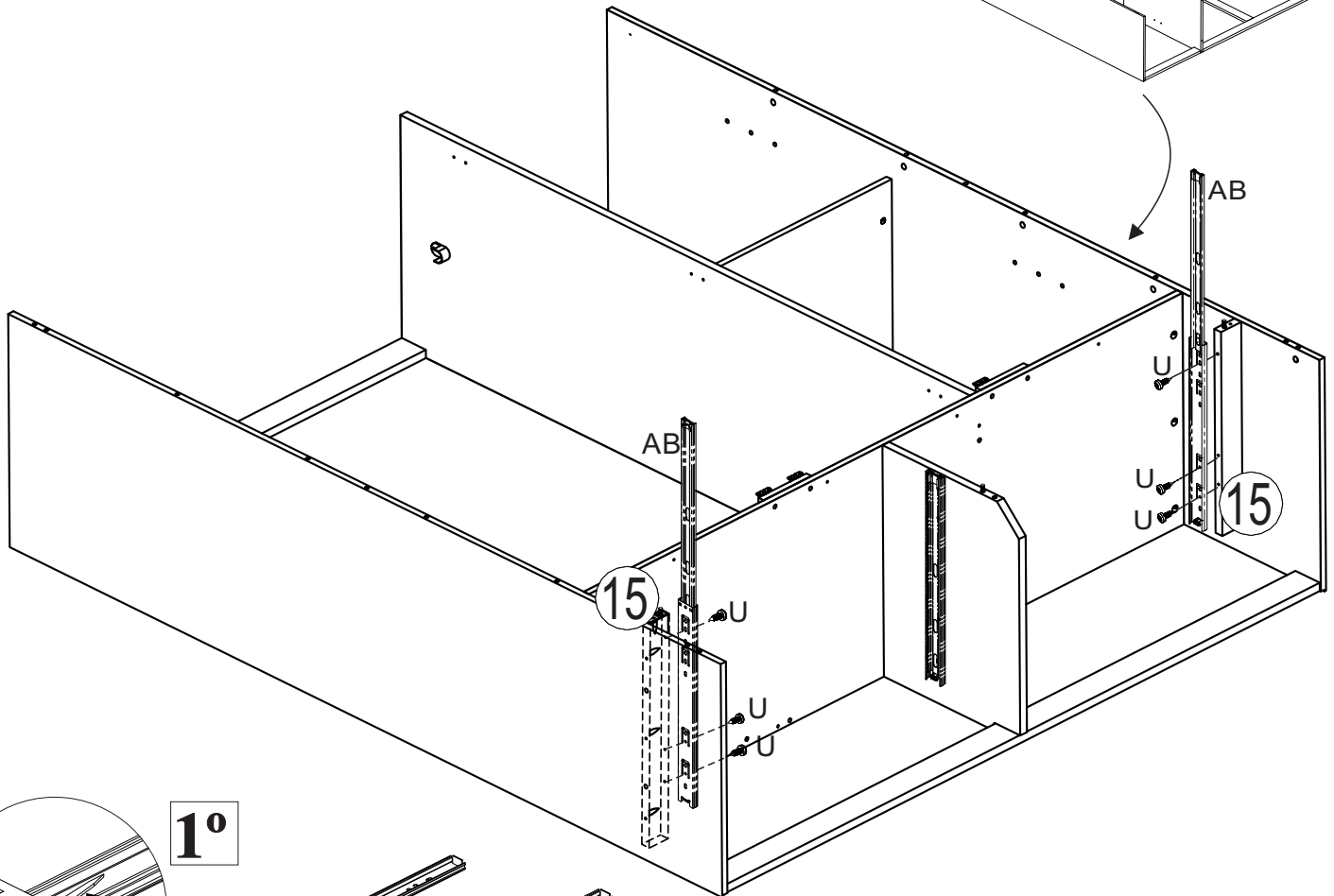

Esta parte da corrediça deve ser montada na lateral da gaveta

Esta parte de la corrediça deve ser colada en la parte lateral de los cajones

PASSO 12) DÉCIMO SEGUNDO PASO

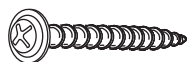

G Parafuso 3,5x30 (2x)
G Tornillo 3,5x30 (2x)



O- Parafuso 3,5x12 (4x)
O- Tornillo 3,5x12 (4x)



D- Tambor minifix (13x)
D- Cilindro minifix (13x)

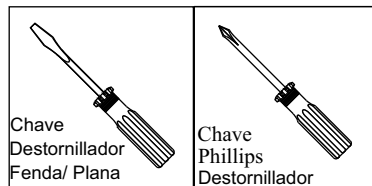
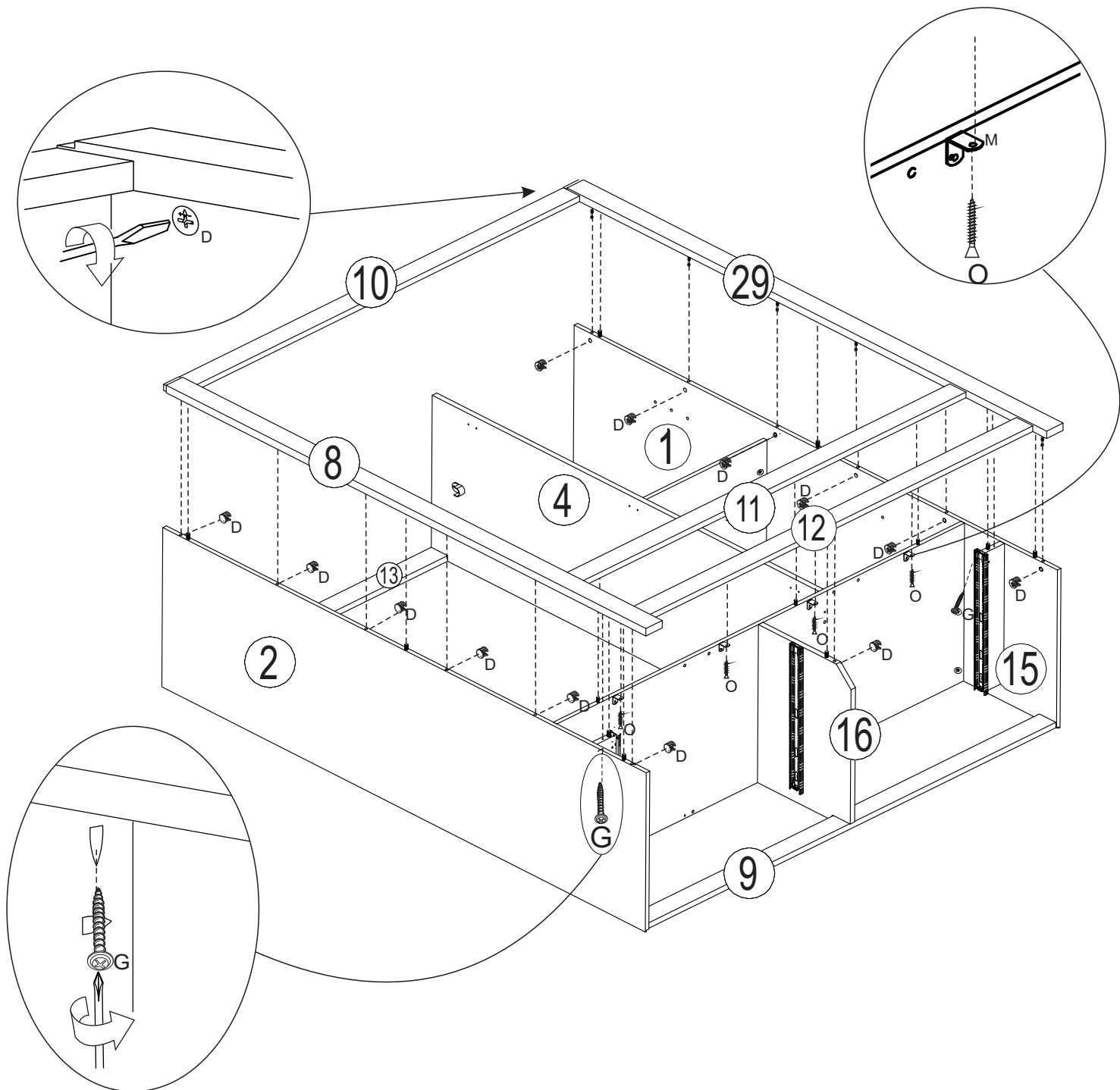

PASSO 13) DÉCIMO TERCER PASO



S- Parafuso 3,5x40 (15x)
S- Tornillo 3,5x40 (15x)



R - Parafuso 3,5x20 (2x)
R - Tornillo 3,5x20 (2x)

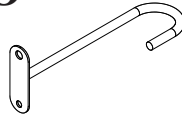

AB- Suporte gancho(1x)

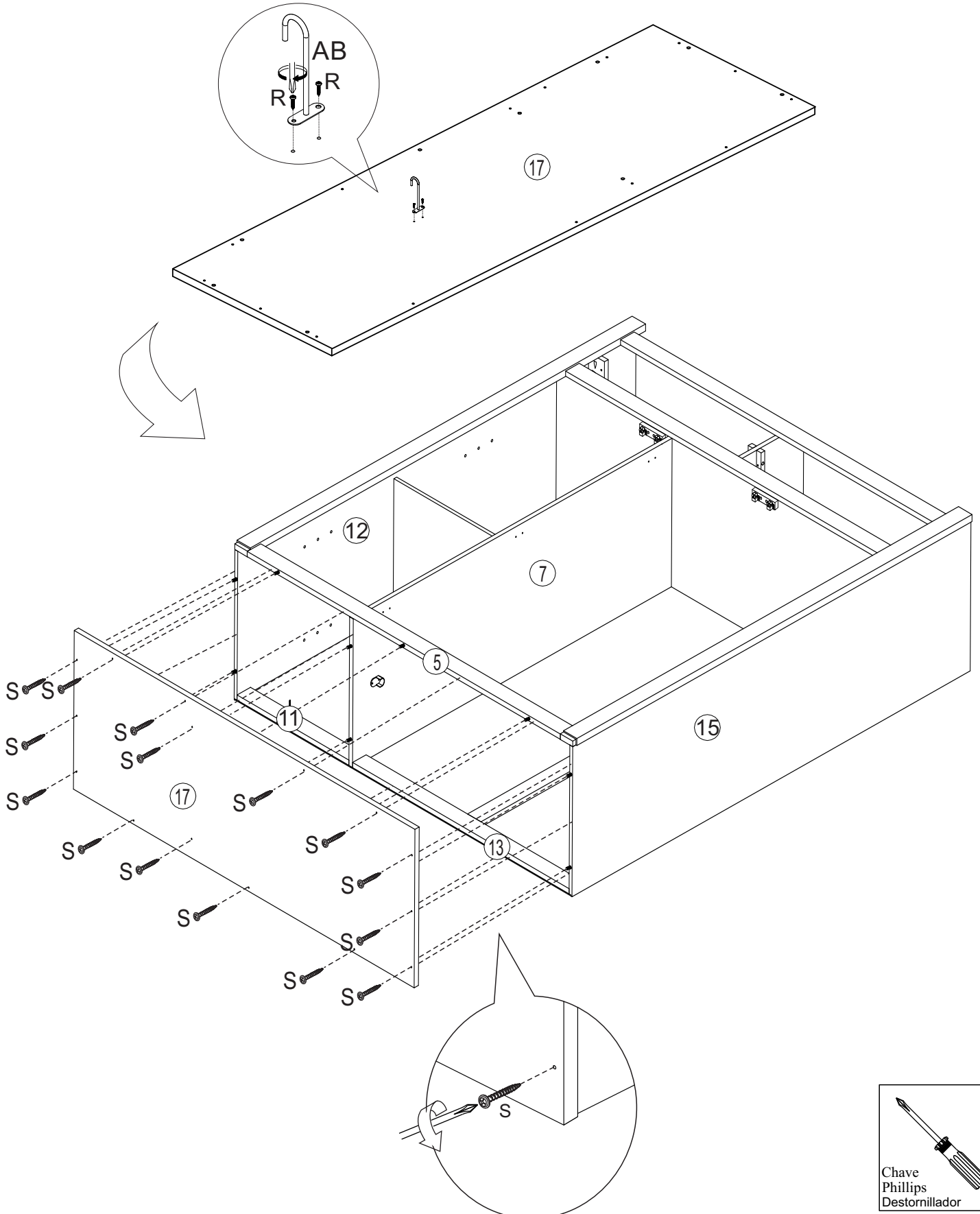

PASSO 14) DÉCIMO CUARTO PASO



- I- Parafuso 5x50 (12x)
- I- Tornillo 5x50 (12x)

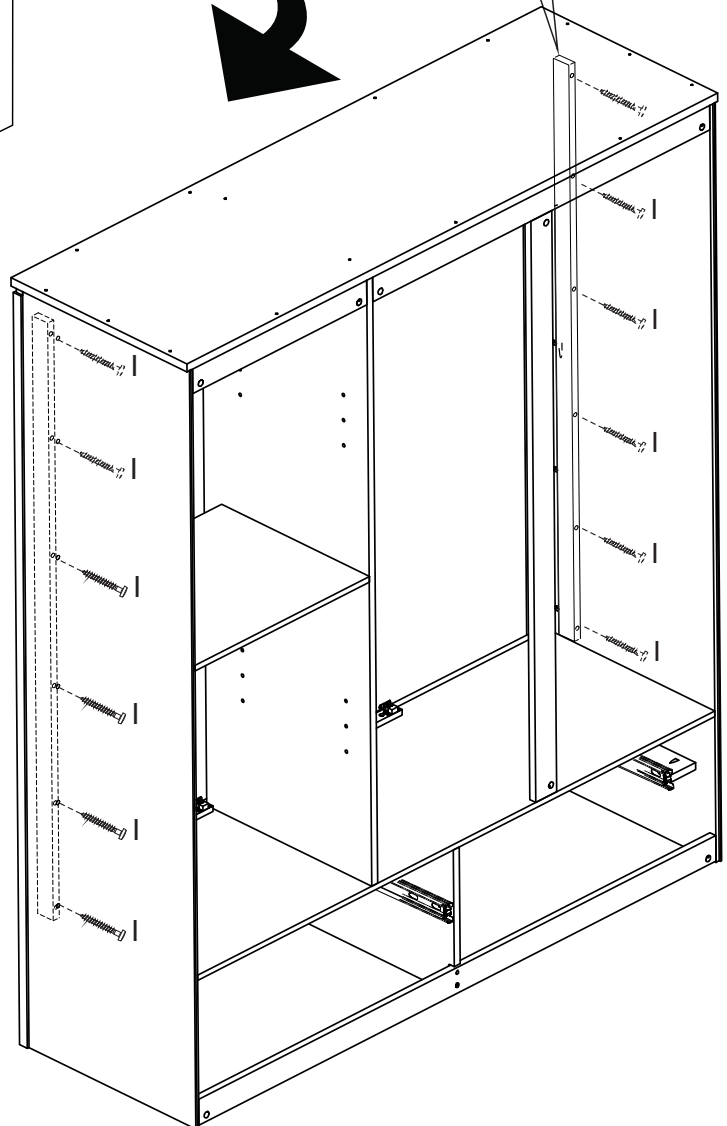
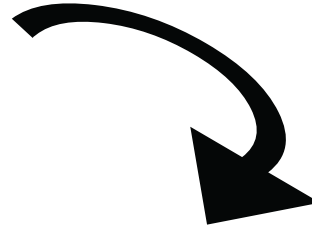
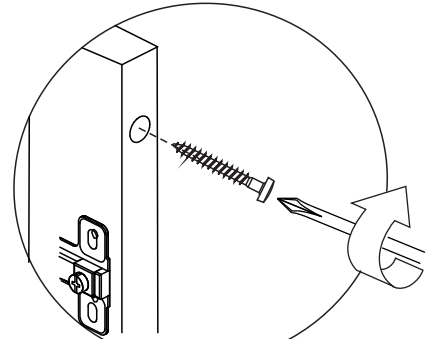
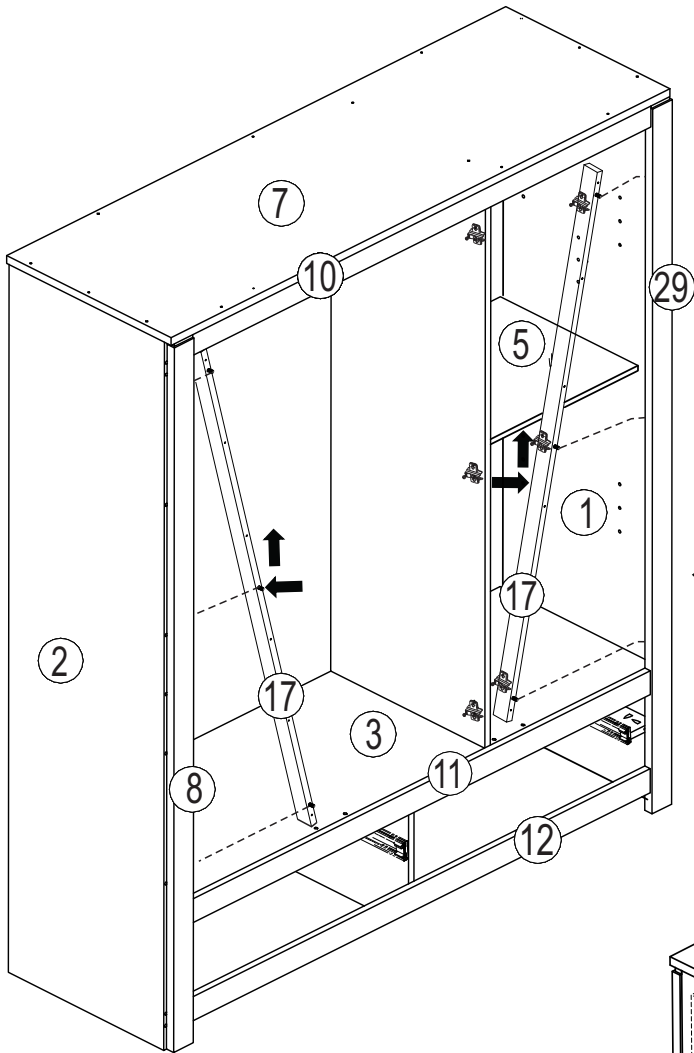

Chave
Phillips
Destornillador

PASSO 15) DÉCIMO QUINTO PASO

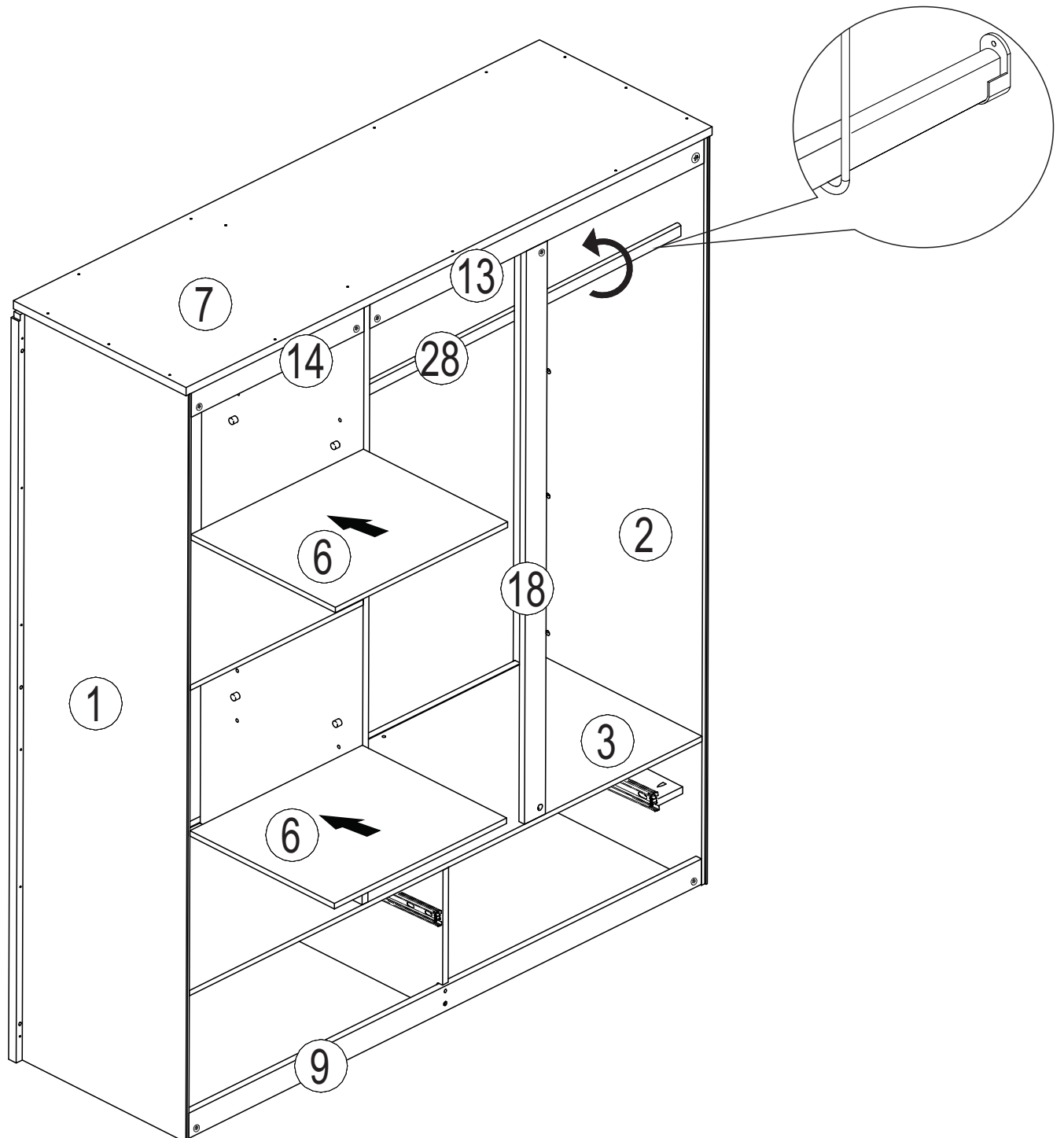

PASSO 16) DÉCIMO SEXTO PASO



F- Prego (22x)

F- Clavo (22x)

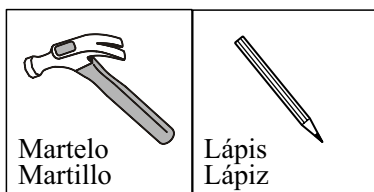
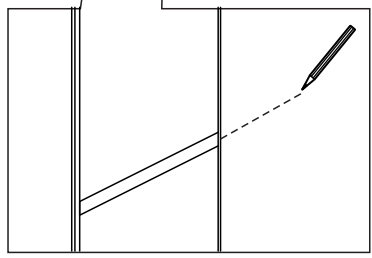
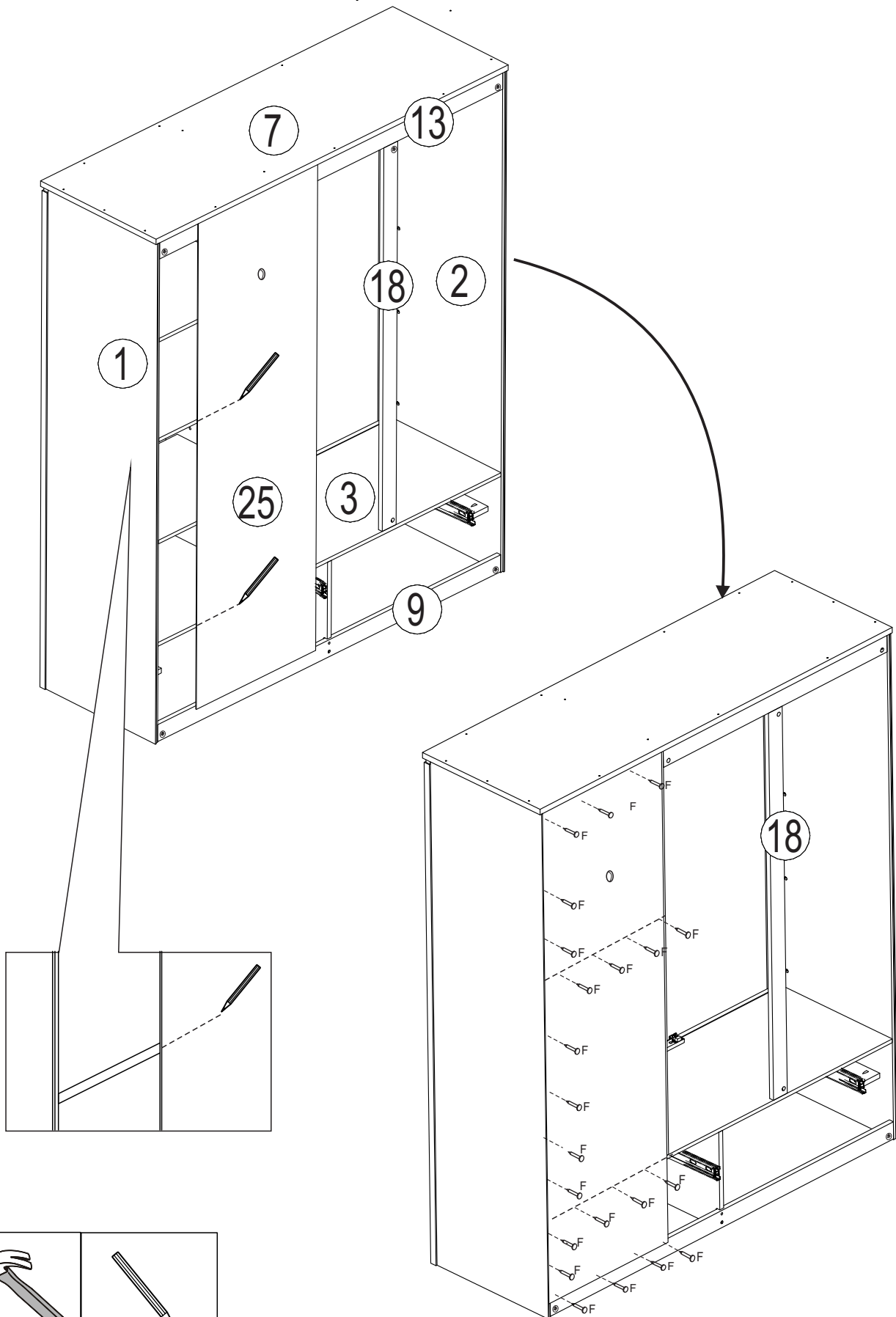

PASSO 17) DÉCIMO SÉPTIMO PASO



F- Prego (21x)
F- Clavo (21x)

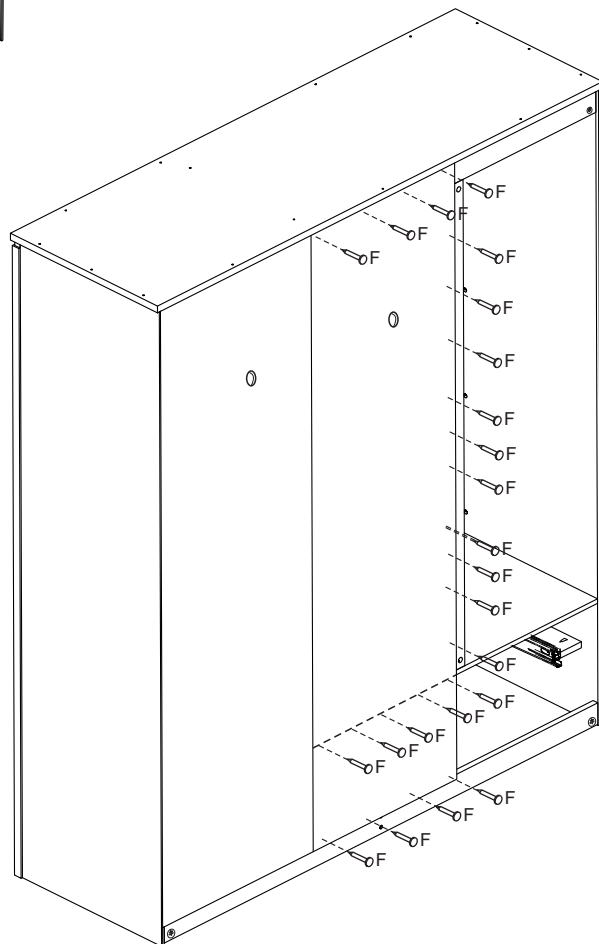
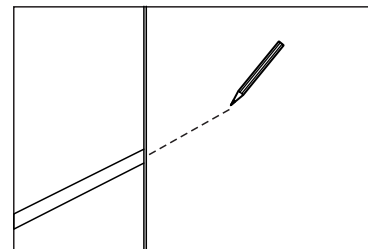
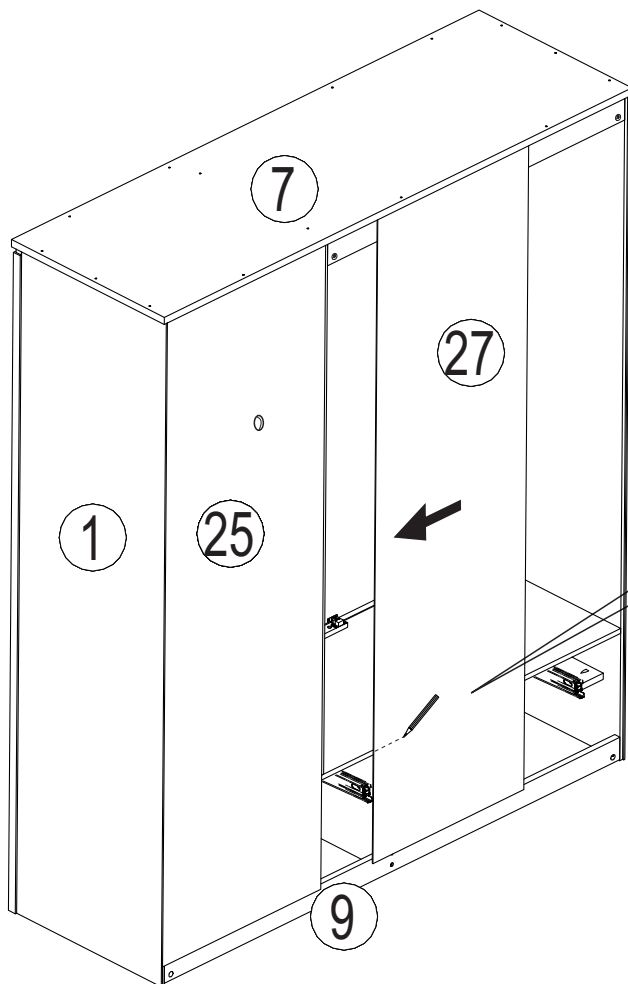

Martelo
Martillo



Lápis
Lápiz

PASSO 18) DÉCIMO OCTAVO PASO



F- Prego (22x)
F- Clavo (22x)

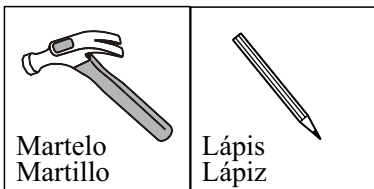
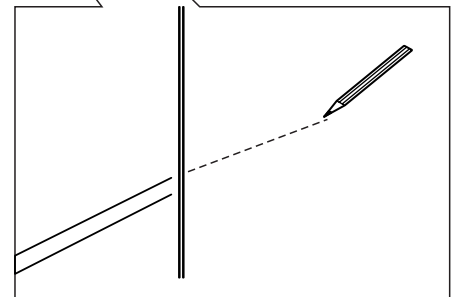
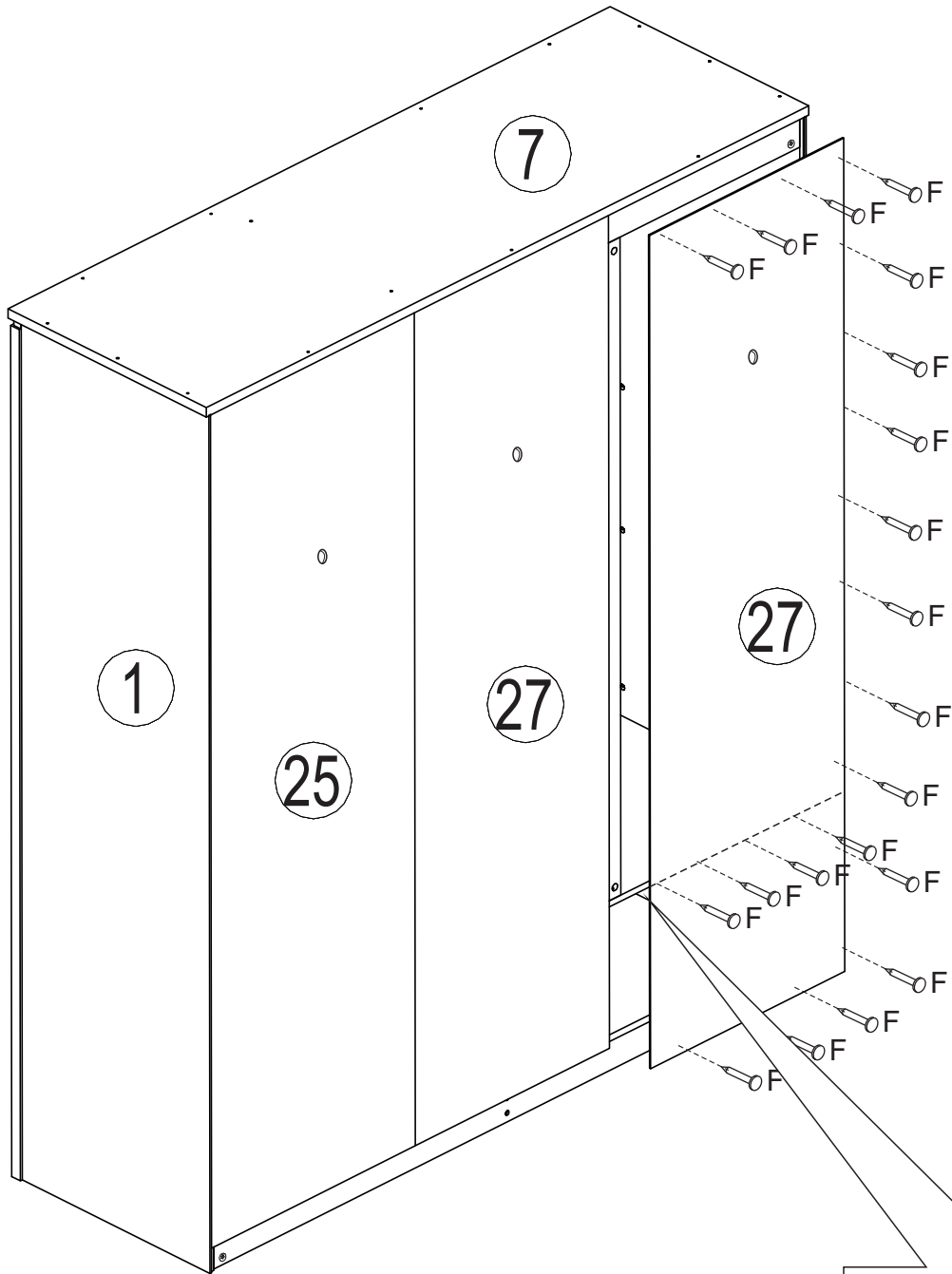

PASSO 19) DÉCIMO NONO PASO



F- Prego (15x)
F- Clavo (15x)



T- Fixador para fundo (15x)
T- Fixador para fundo (15x)

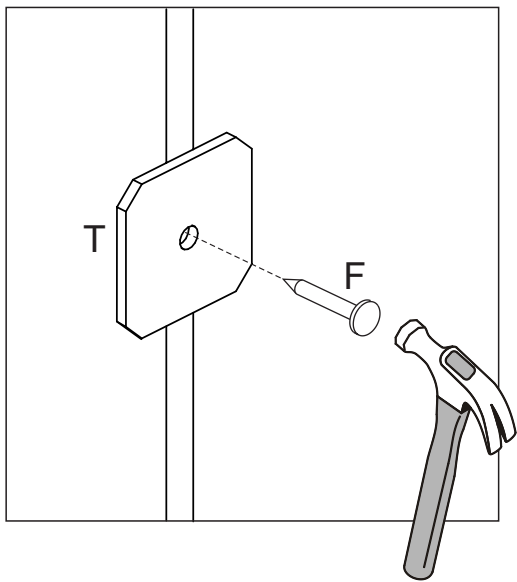
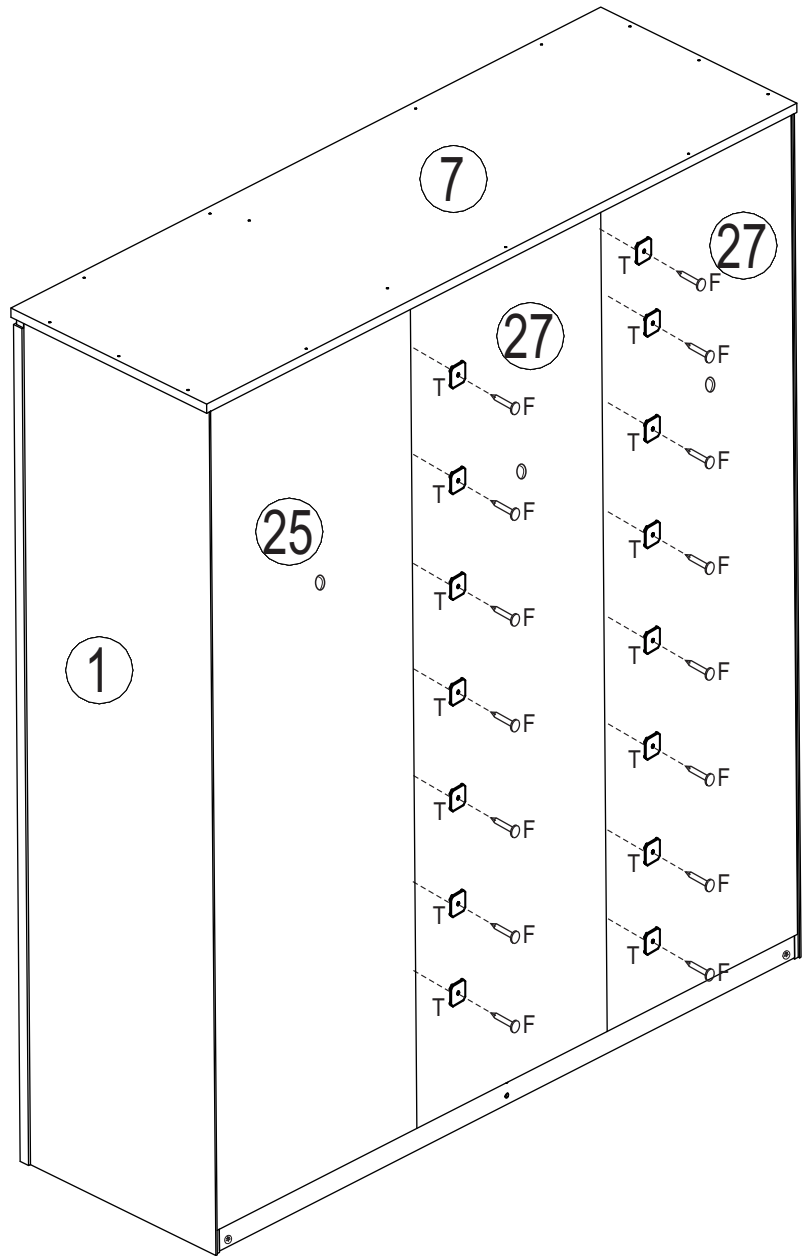

Martelo
Martillo

PASSO 20) VIGÉSIMO PASO

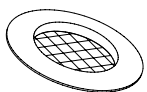

K - Tampa para ventilação (3x)
K - Tapón para ventilación (3x)

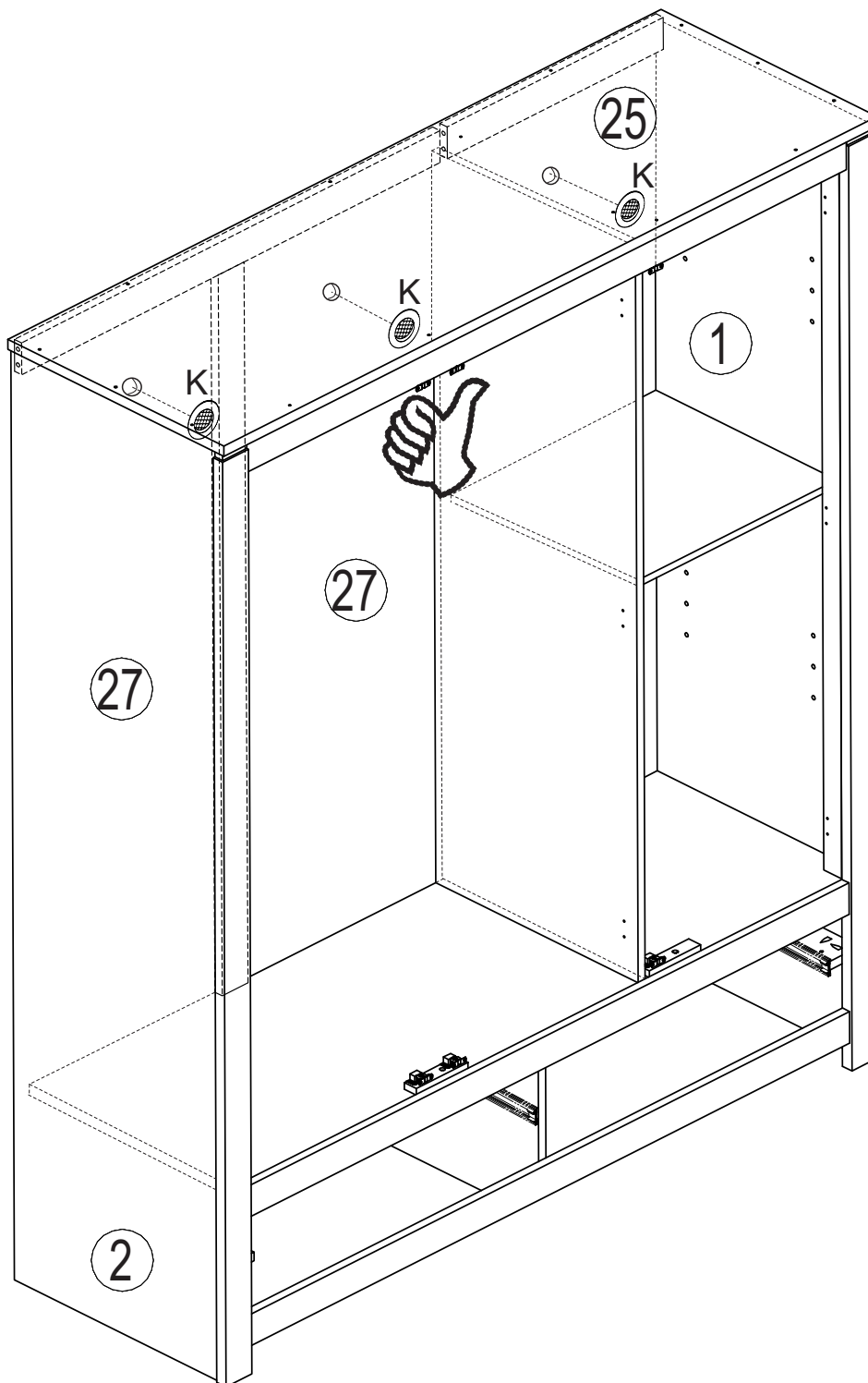

PASSO 21) VIGÉSIMO PRIMER PASO



H - Parafuso 3,5x14 (20x)
H - Tornillo 3,5x14 (20x)

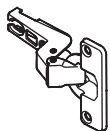

J - Dobradiça (6x)
J - Bisagra (6x)



Q - Fecho macho (4x)
Q - Cierre macho (4x)

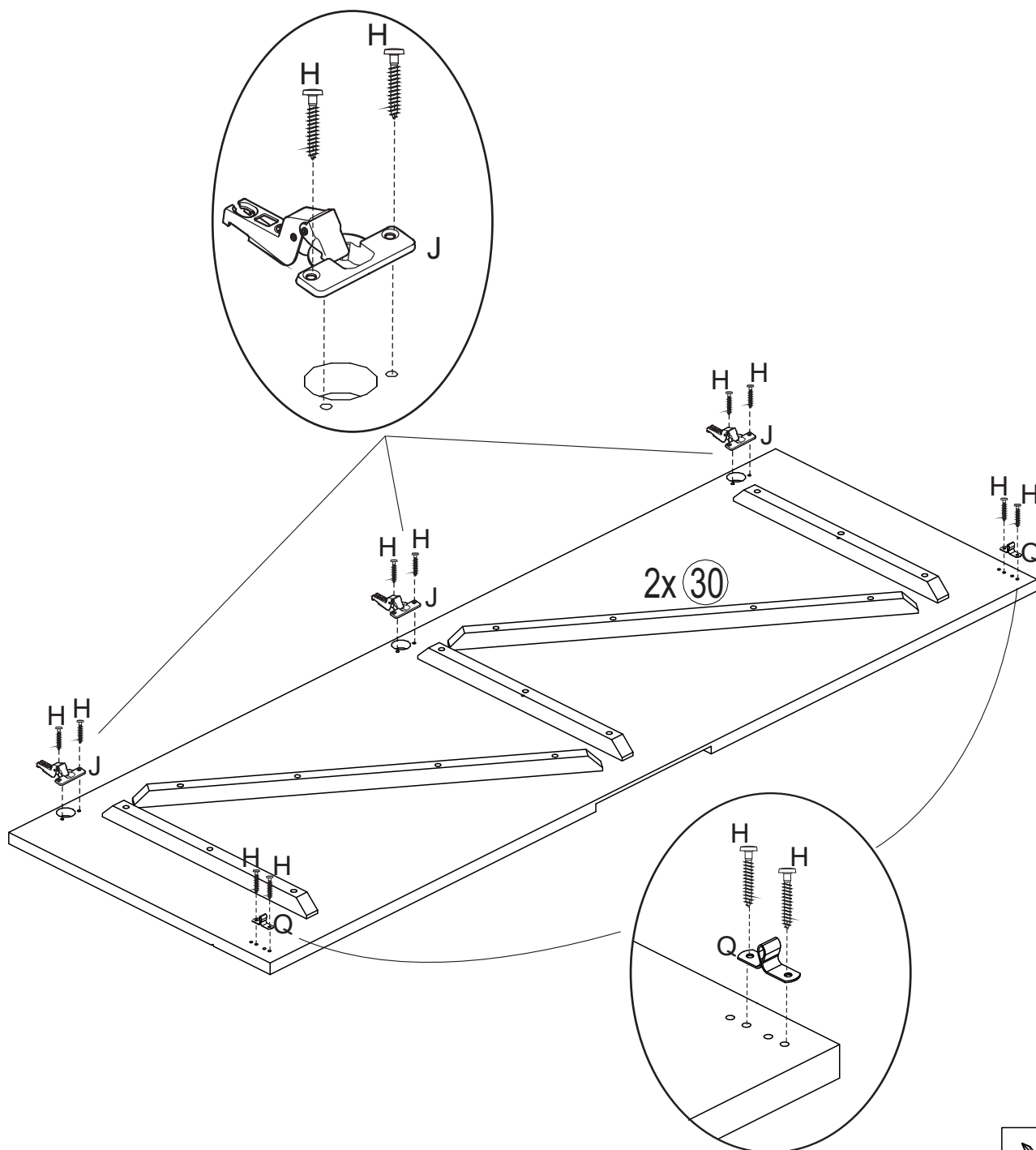

Ajustar conforme necessidade
Ajustar de acordo com necessidade



Chave
Phillips
Destornillador

PASSO 22) VIGÉSIMO SEGUNDO PASO



H - Parafuso 3,5x14 (10x)
H - Tornillo 3,5x14 (10x)



J - Dobradiça (3x)
J - Bisagra (3x)



Q - Fecho macho (2x)
Q - Cierre macho (2x)

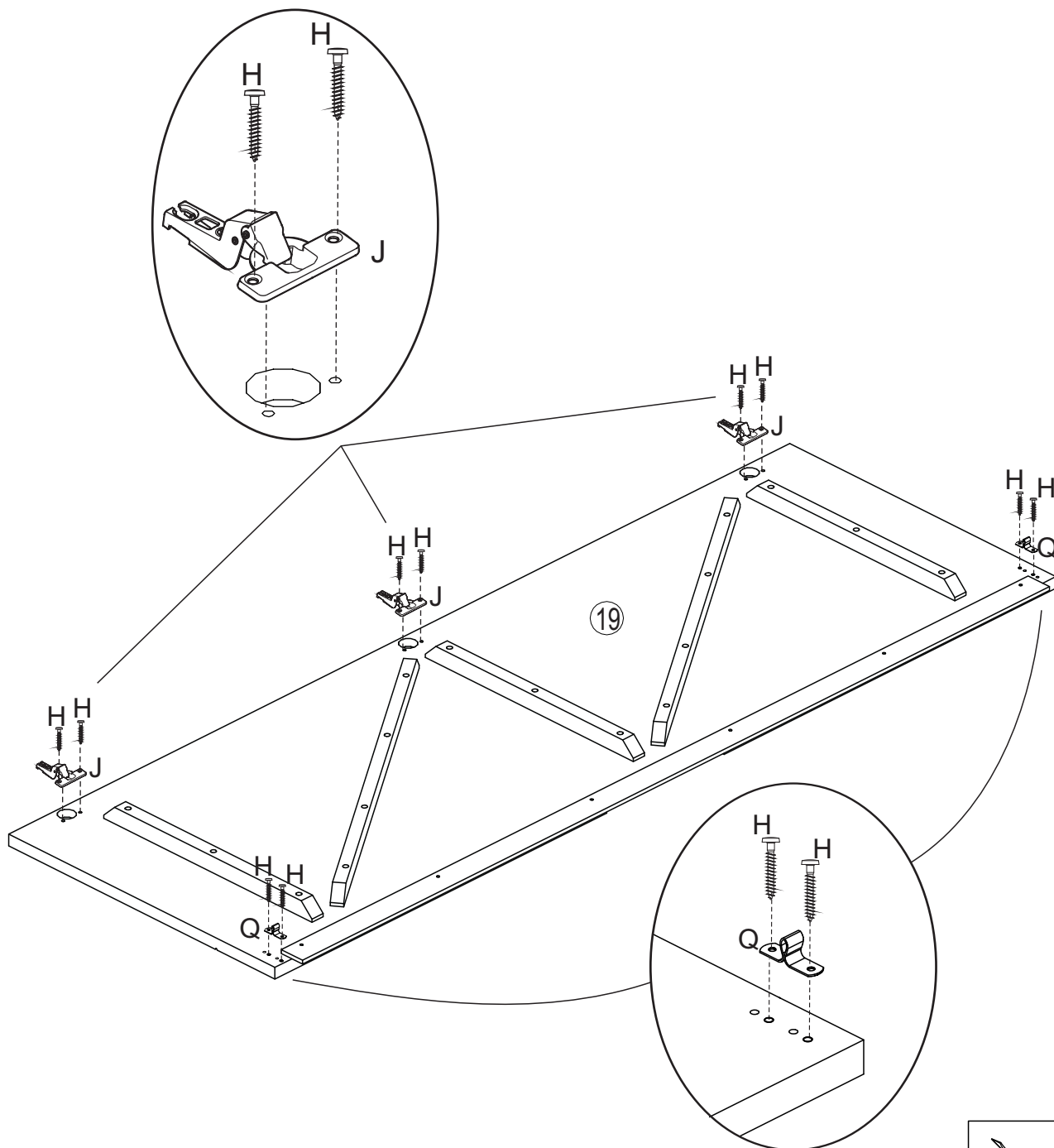

Ajustar conforme necessidade
Ajustar de acordo com necessidade



PASSO 23) VIGÉSIMO TERCER PASO

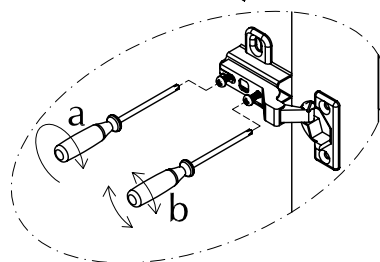
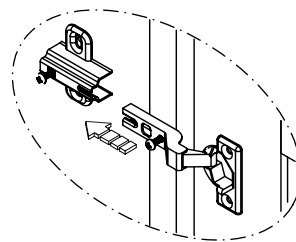
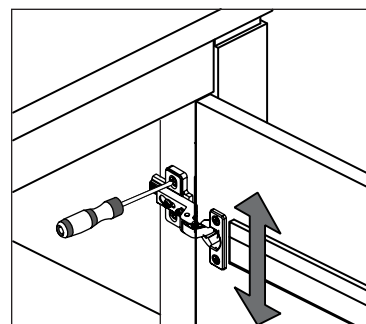
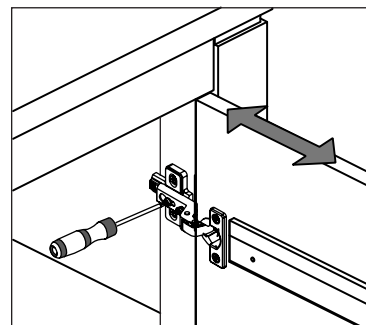
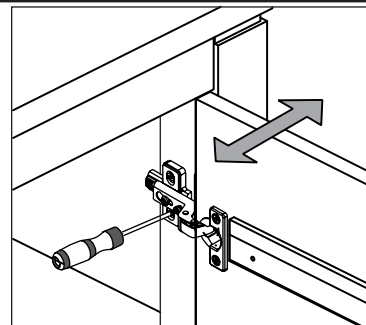
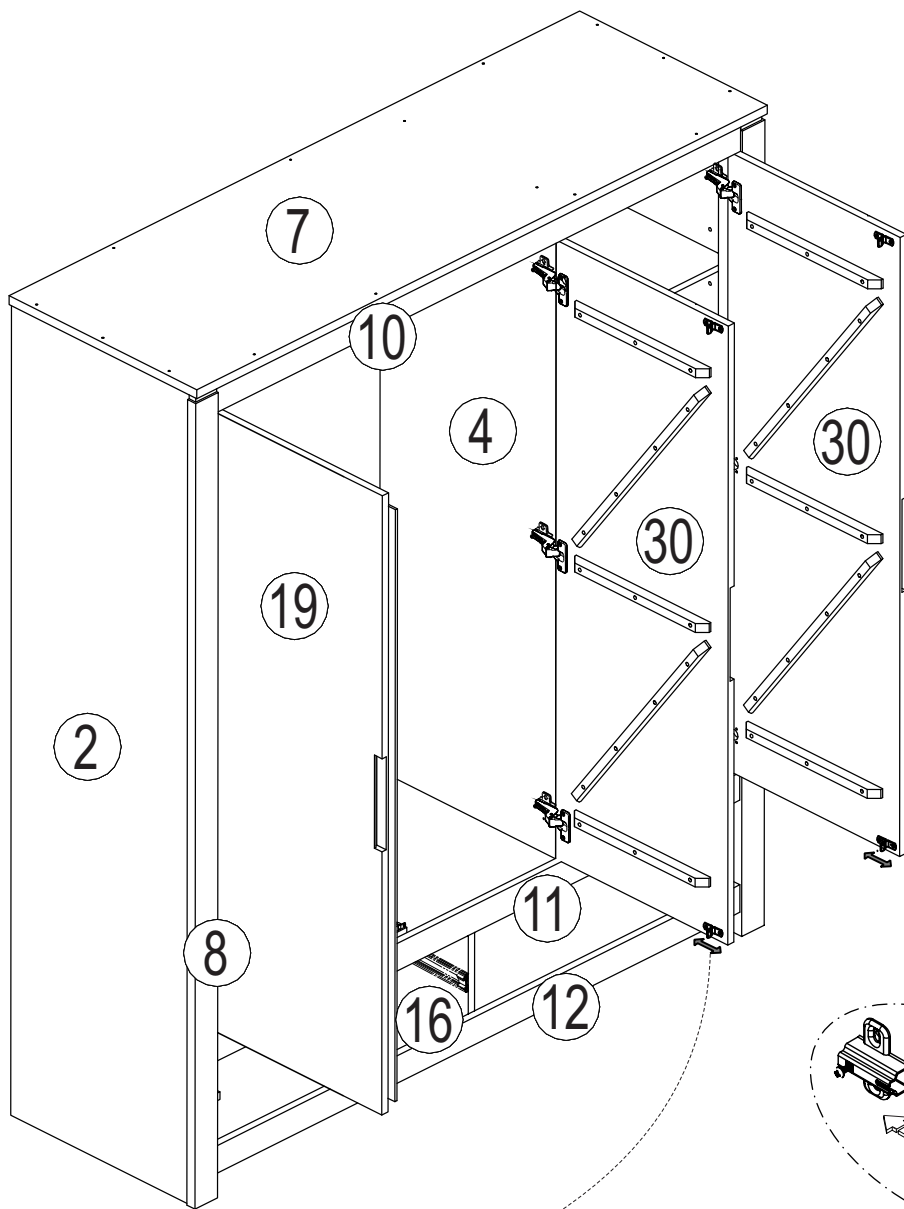

Ajustar conforme necessidade
Ajustar de acordo com necessidade

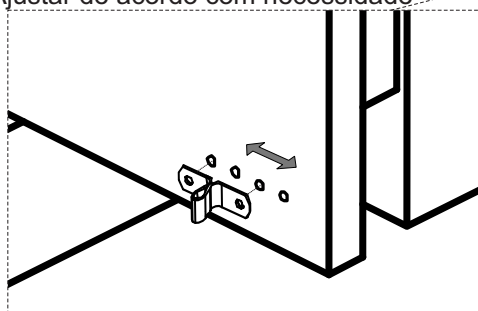

PASSO 24) VIGÉSIMO CUARTO PASO



B- Cavilha 6x30 (16x)
B- Tarugo 6x30 (16x)



D- Tambor minifix (8x)
D- Cilindro minifix (8x)



E- Parafuso minifix (8x)
E- Tornillo minifix (8x)



U - Parafuso 3,5x12 (12x)
U - Tornillo 3,5x12 (12x)

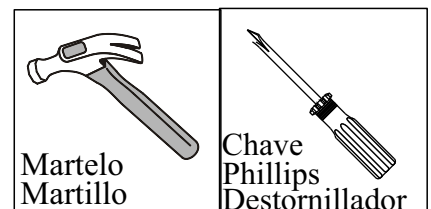
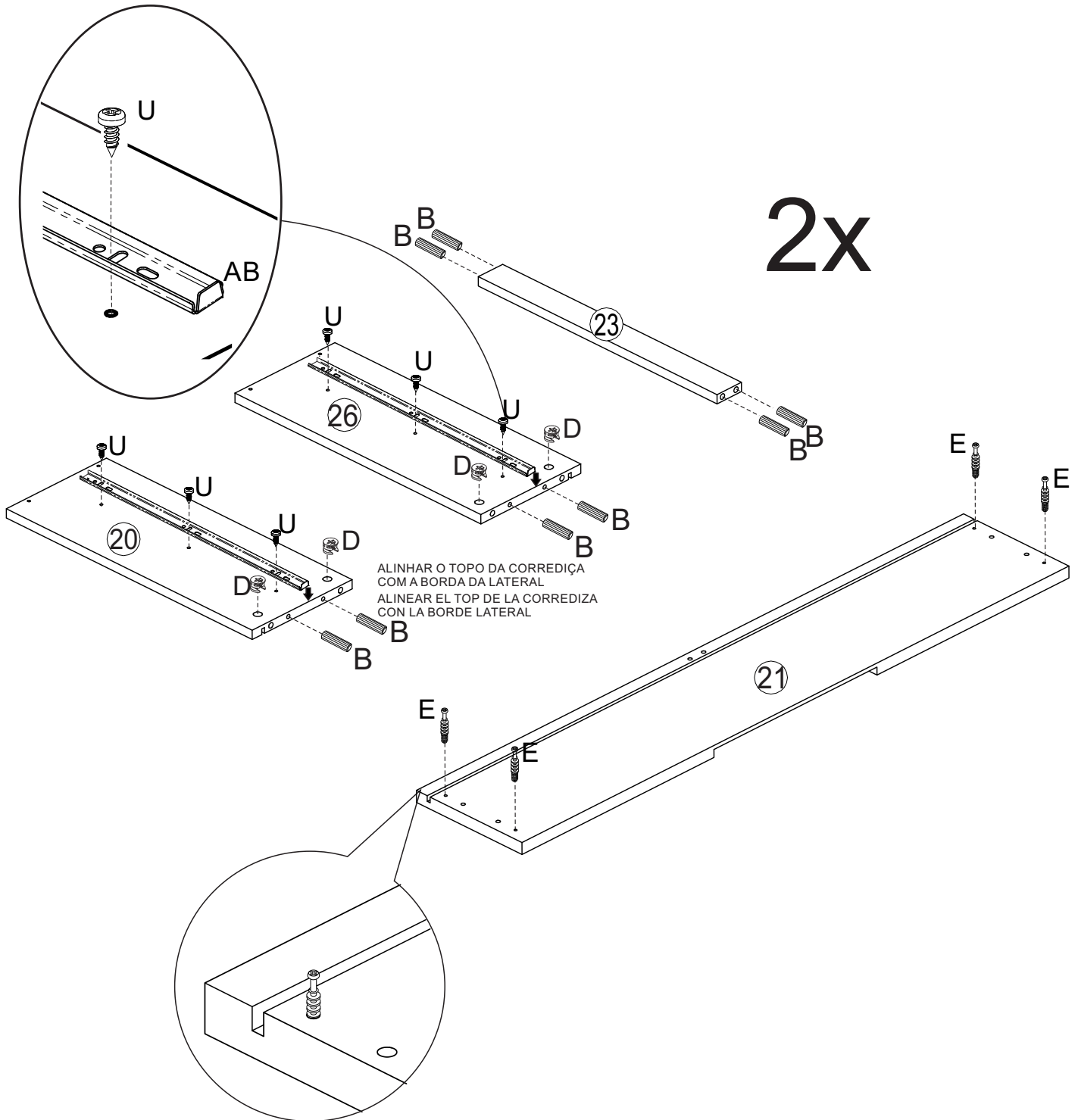

PASSO 25) VIGÉSIMO QUINTO PASO



S- Parafuso 3,5x40 (8x)
S- Tornillo 3,5x40 (8x)

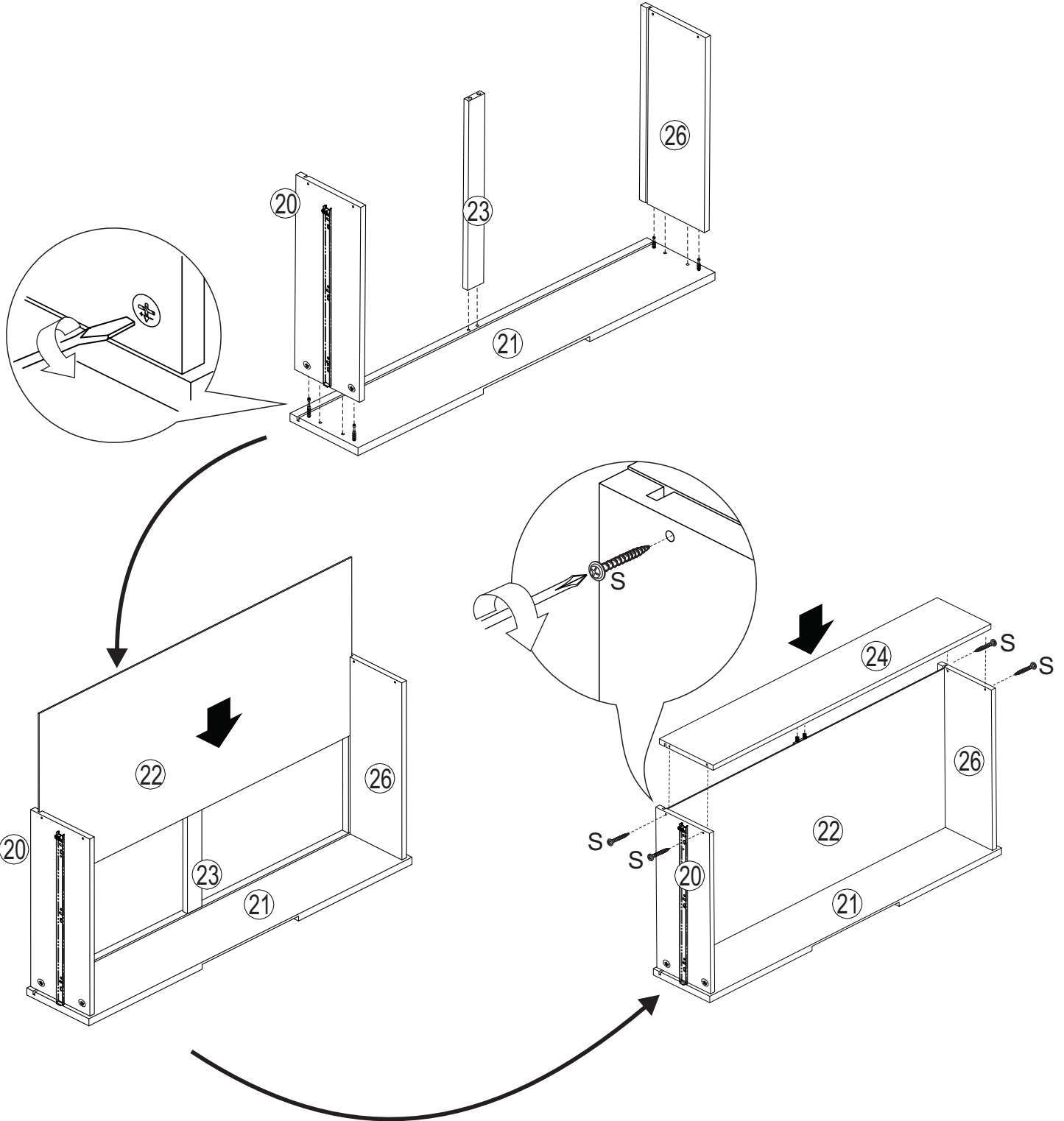

PASSO 26) VIGÉSIMO SEXTO PASO

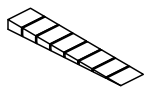

- P- Calço nivelador (2x)
- P- Soporte nivelador (2x)

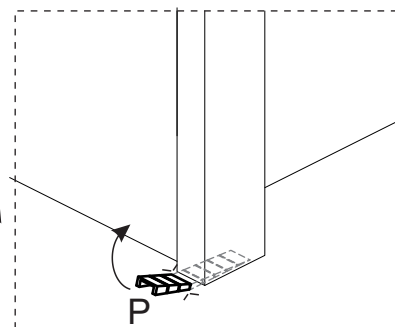
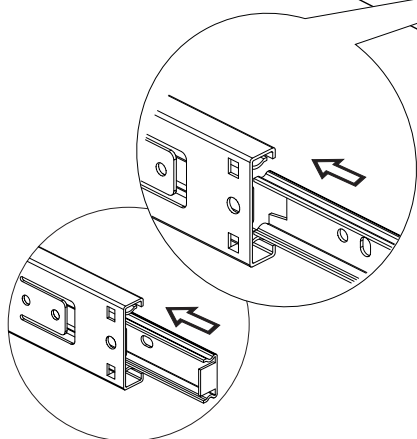
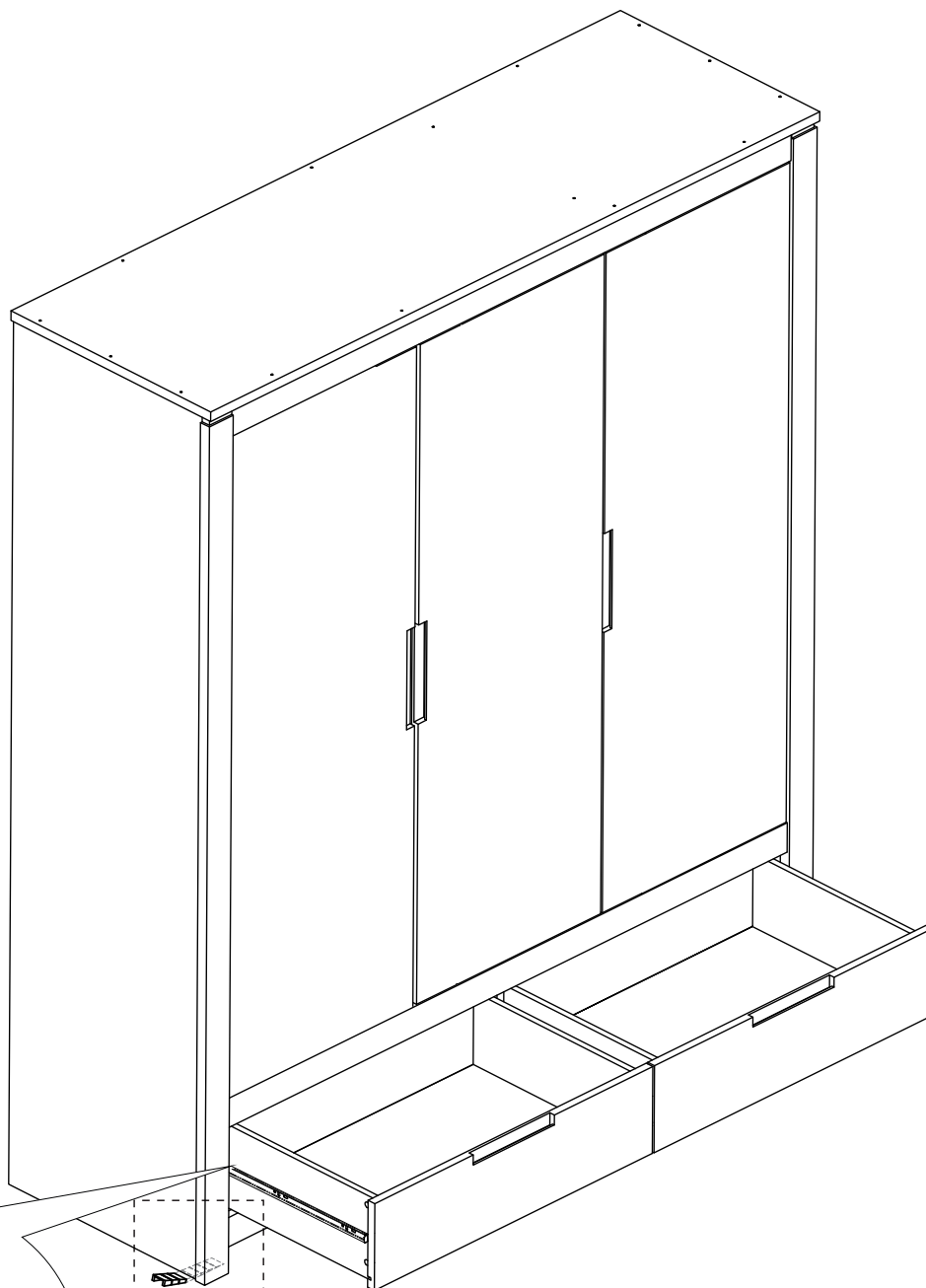

PASSO 27) VIGÉSIMO SÉPTIMO PASO



AA- Fita segurança (2x) O - Parafuso 3,5x12 (2x)
 AA- Cinta de seguridad (2x) O - Tornillo 3,5x12 (2x)

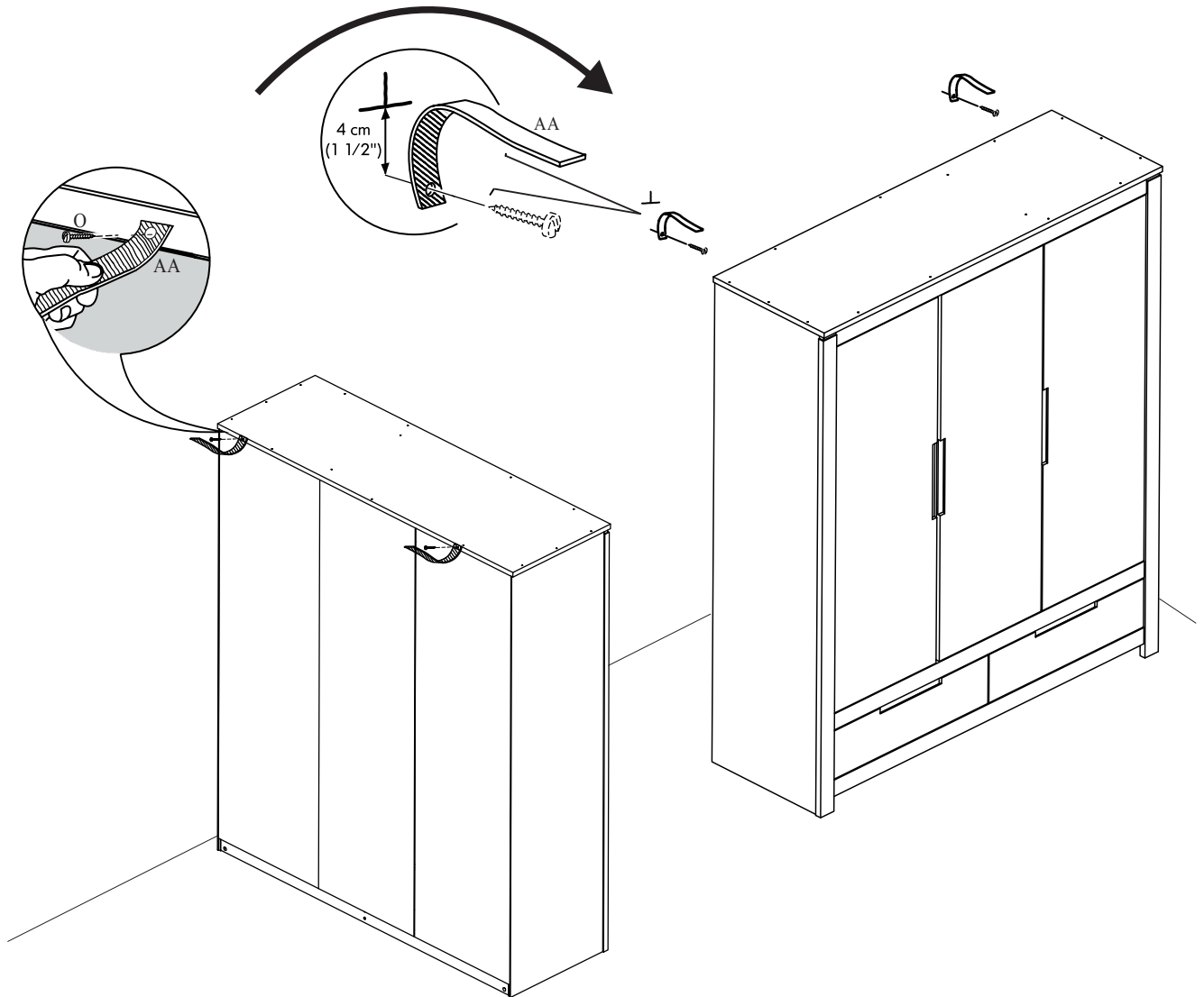

IMPORTANTE!

Recomendamos que fixe os móveis à parede com o suporte de segurança incluído, para evitar que tombe se uma criança tentar subir ou pendurar-se nele. Existem vários tipos de paredes e divisões, que requerem diferentes tipos de ferragens de fixação. Use ferragens de fixação adequada para sua casa (não incluída).

O parafuso com o suporte de segurança serve apenas para fixar o suporte de segurança ao móvel.

IMPORTANTE!

Recomendamos que una los muebles a la pared con o con el soporte de seguridad que se incluye, para evitar que se vuelque si un niño intenta subir o colgar en él. Hay varios tipos de paredes y divisiones que requieren los diferentes tipos de herrajes de sujeción. Utiliza herrajes de montaje apropiado para su hogar (no incluido). El tornillo con el apoyo del seguridad sólo sirve para fijar o soporte de seguridad a móvil.

EXEMPLOS DE FIXAÇÃO ACONSELHADAS:
 EXEMPLOS DE FIJACIÓN RECOMENDADO:

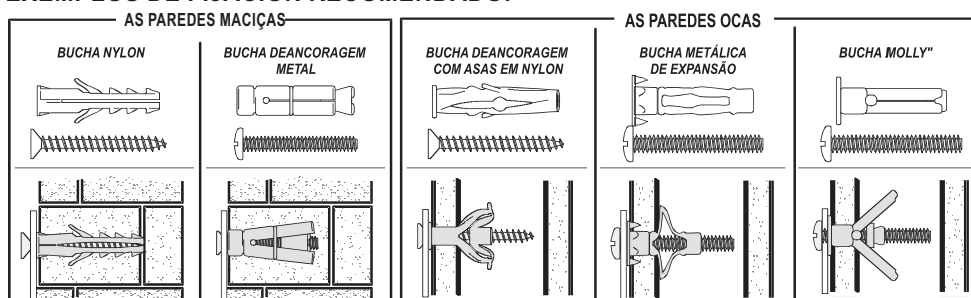

CUIDADOS COM O MÓVEL

CUIDADOS CON EL MUEBLE

Para a limpeza e conservação deste produto, use apenas um pano macio, umedecido com água e sabão neutro (sem amônia).

Não use álcool, detergentes, abrasivos, etc...

Não deixe este produto em contato com o sol, fonte de calor ou ambiente com muito pó.

Para mejor limpieza y conservacion del producto, use solamente un paño suave, húmedo con agua y jabão neutro (sin amonia).

No use alcohol, detergentes, abrasivos, etc...

No deje este producto en contacto el sol, lugares de mucho calor y ambiente con mucho polvo.

