

MODULO AÉREO SMART GR4220S

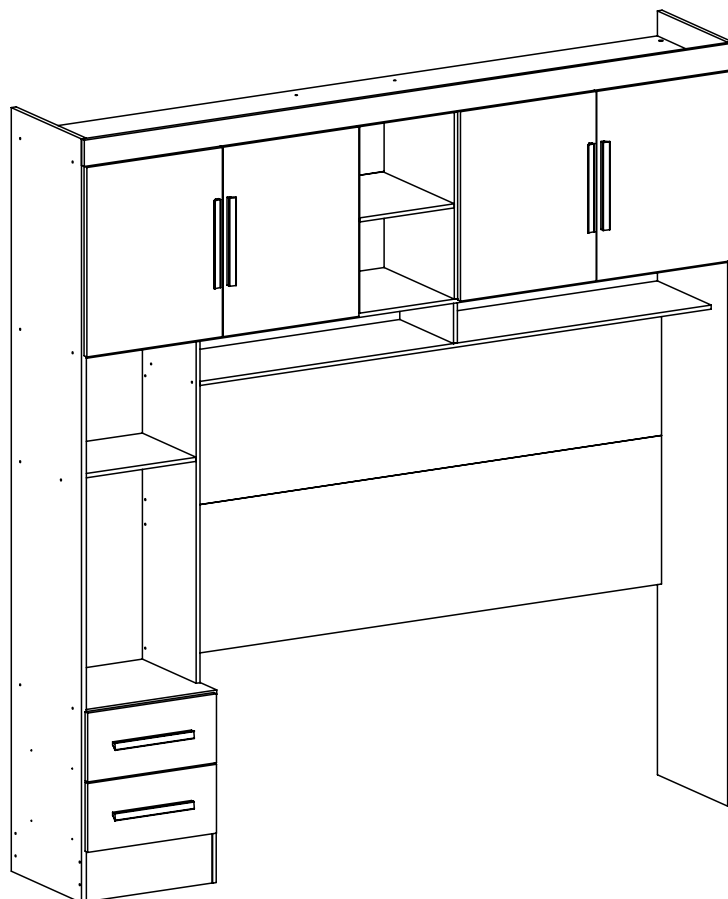

Informações Úteis

É recomendada a prévia leitura de toda a instrução de montagem e conferência das peças e componentes antes de iniciar a montagem do produto.

A montagem do produto deverá ser feita em superfície limpa e plana. Aconselhamos utilizar a embalagem do produto para forrar o chão a fim de não danificar o produto.

Durante a montagem evite batidas e contato com objetos cortantes. Observar as cargas máximas suportado pelo produto.

Limpeza

Retire o pó com uma flanela seca e depois utilize um pano macio umedecido com água.

Não utilizar produtos químicos e abrasivos

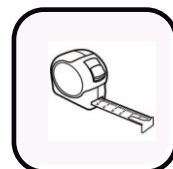
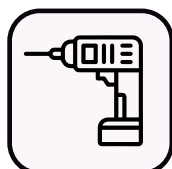

Nº DA PEÇA	DESCRIÇÃO	QTD	CÓD. BRANCO	CÓD. CINAMOMO	CÓD. CINAMOMO OFF WHITE	CÓD. CINAMOMO CAPPUCCINO
1	CABECEIRA 1620X422X12	2	35064	34665	34665	34665
2	CHAPÉU 2032X385X12	1	35071	34666	34666	34666
3	CHAPÉU 400X295X12	1	31168	30783	30783	30783
4	COSTA 1400X419X3	1	35135	34815	34815	34815
5	COSTA 1637X156X3	1	35136	34667	34667	34667
6	COSTA 2056X271X3	2	35139	34674	34674	34674
7	DIVISÃO 142X295X12	1	31159	30807	30807	30807
8	DIVISÃO 530X385X12	2	35090	34668	34668	34668
9	ENCABEÇAMENTO 2062X75X15	1	35092	34669	34669	34669
10	FRENTE GAVETA 408X196X15	2	32990	32967	32971	34791
11	FUNDO DE GAVETA 372X363X3	2	35142	34854	34854	34854
12	LATERAL 2170X385X15	1	32993	32773	32773	32773
13	LATERAL 2170X385X15 CRIADO	1	32994	32774	32774	32774
14	LATERAL 535X385X12	1	31156	30802	30802	30802
15	LATERAL 998X295X12	1	31154	30795	30795	30795
16	LATERAL DE GAVETA 360X90X12	4	28405	30352	30352	30352
17	PORTA 538X430X15	4	35118	34798	34670	34796
18	RODAPÉ FRONTAL 400X150X15	1	31158	30805	30805	30805
19	RODAPÉ TRASEIRO 400X150X15	1	30806	30806	30806	30806
20	TAMPO 1620X295X12	1	35124	34671	34671	34671
21	TAMPO 2032X385X12	1	35125	34672	34672	34672
22	TAMPO 300X385X12	1	35126	34673	34673	34673
23	TAMPO 413X385X12	1	31150	30791	30791	30791
24	TRASEIRO DE GAVETA 352X90X12	2	34421	30794	30794	30794

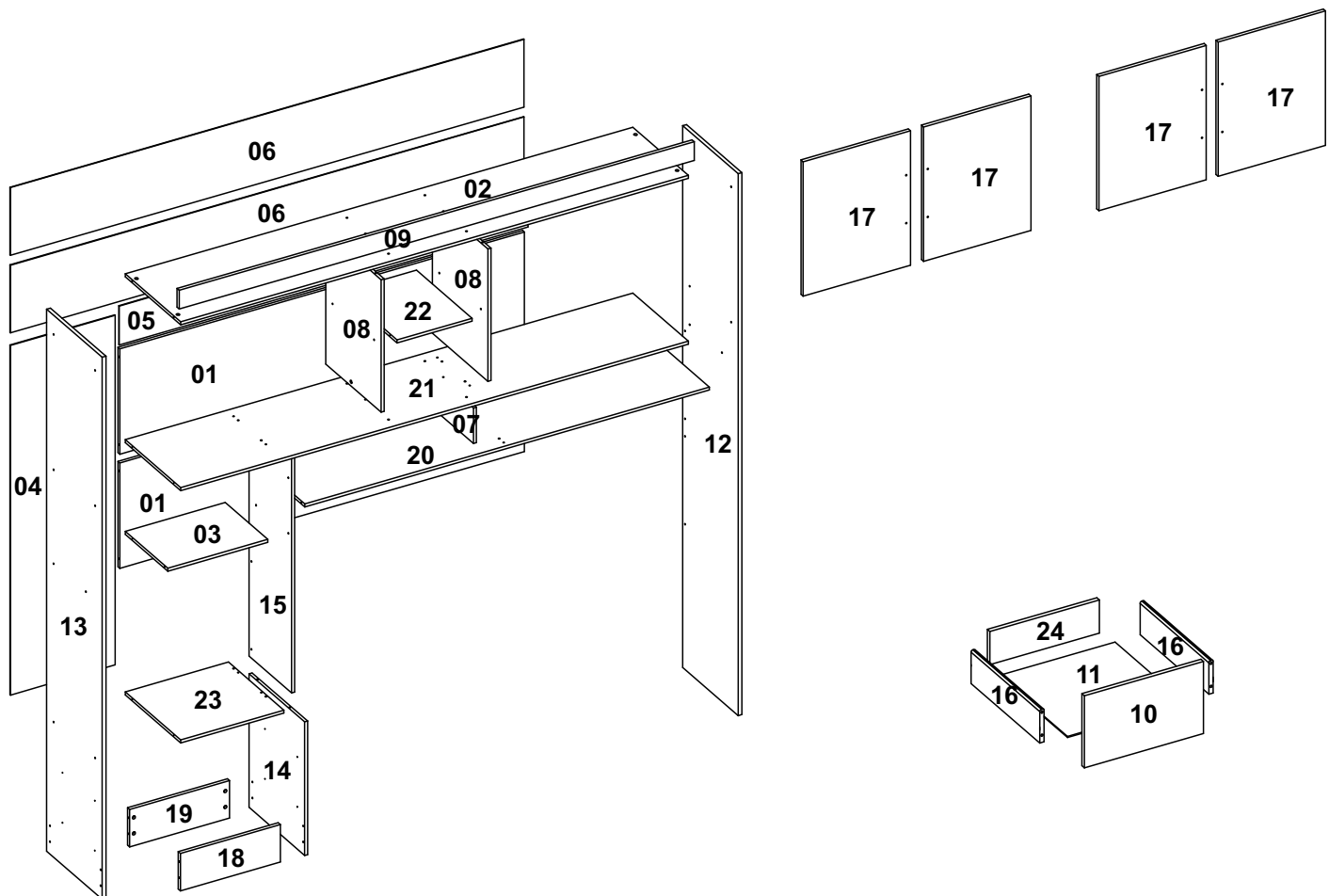

Lista de Ferragens

Parafuso 4,0x40 - Cod.3983

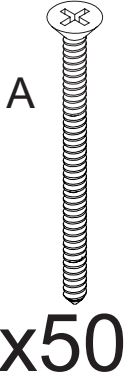

Parafuso 3,5x12 Cód.3385



Porca plástica Cód.3991



Cavilha 6x30 Cod.3881

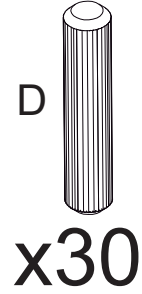

6x50-Cod 8686

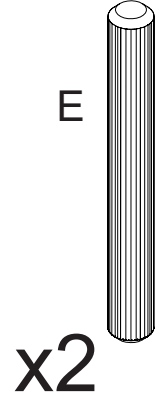

Prego 10x10 Cód.33412

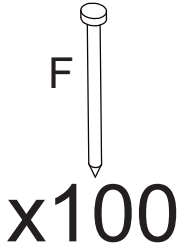

Cod 3872

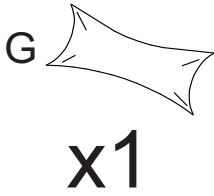

12x12-Cod 33413

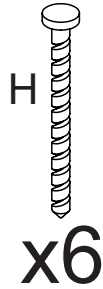

2056mm

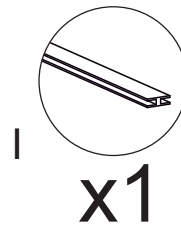

Sapata simples Cód.31330

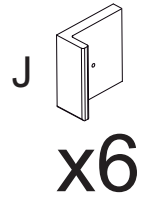

Cod 3882

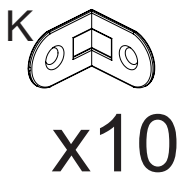

3,5x25-cod 7182



192MM-Cod 23432

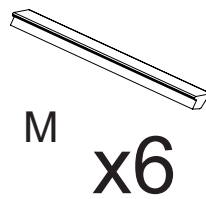

3,5x25-Cod 3870

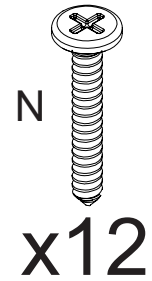

Cod 3384

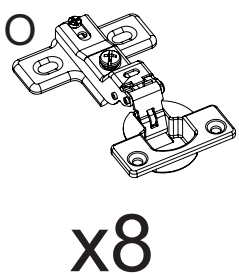

6x20-Cod 26366



Cod 3877

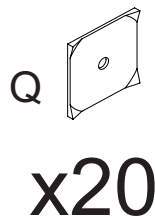

300MM-Cod 29265

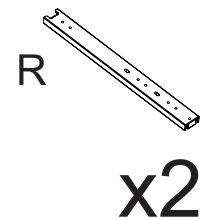

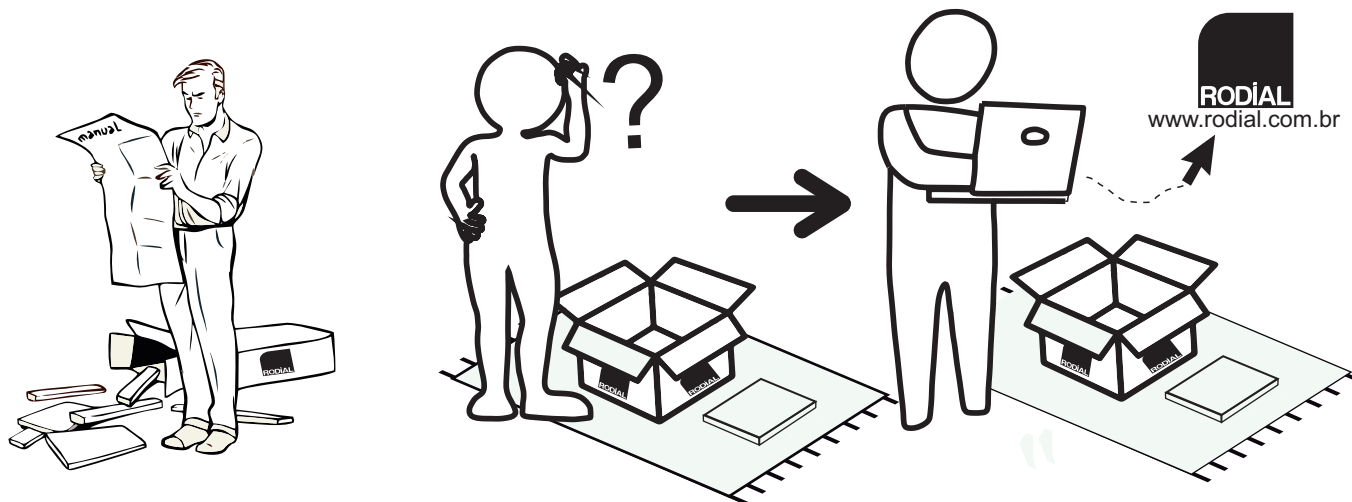
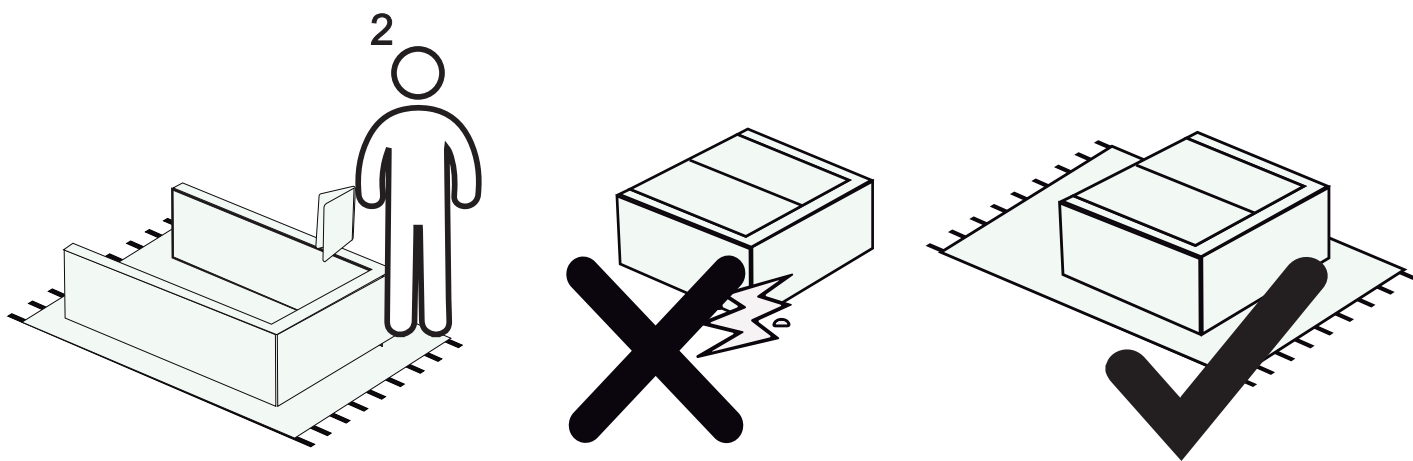

1

Atenção

Esse produto permite a montagem com o criado em ambos os lados, verifique qual lado fica melhor no ambientes antes de iniciar a montagem

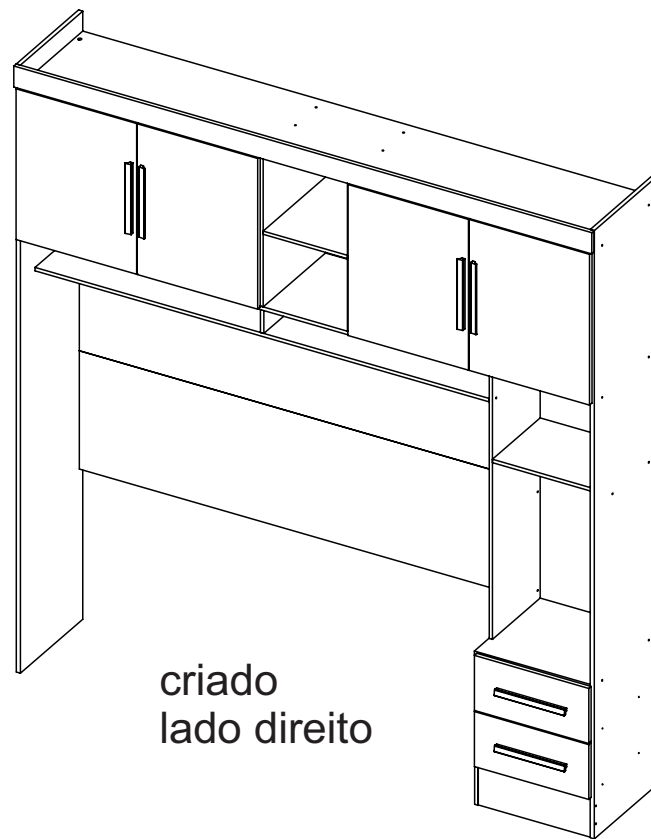
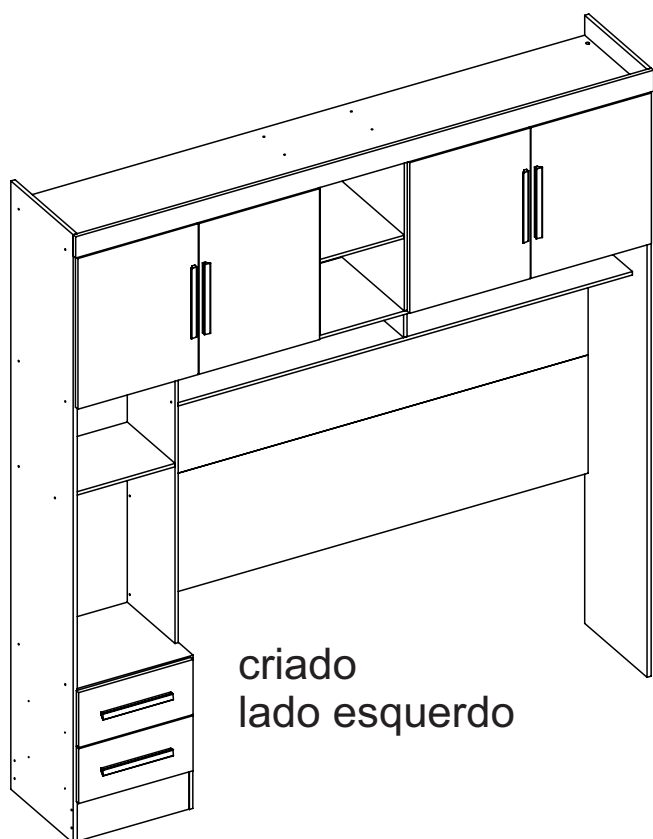

Montagem criado lado esquerdo

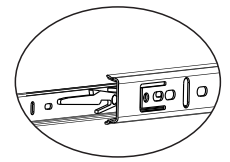

Pressione a trava para desmontar a correia para ser usada na montagem da gaveta.

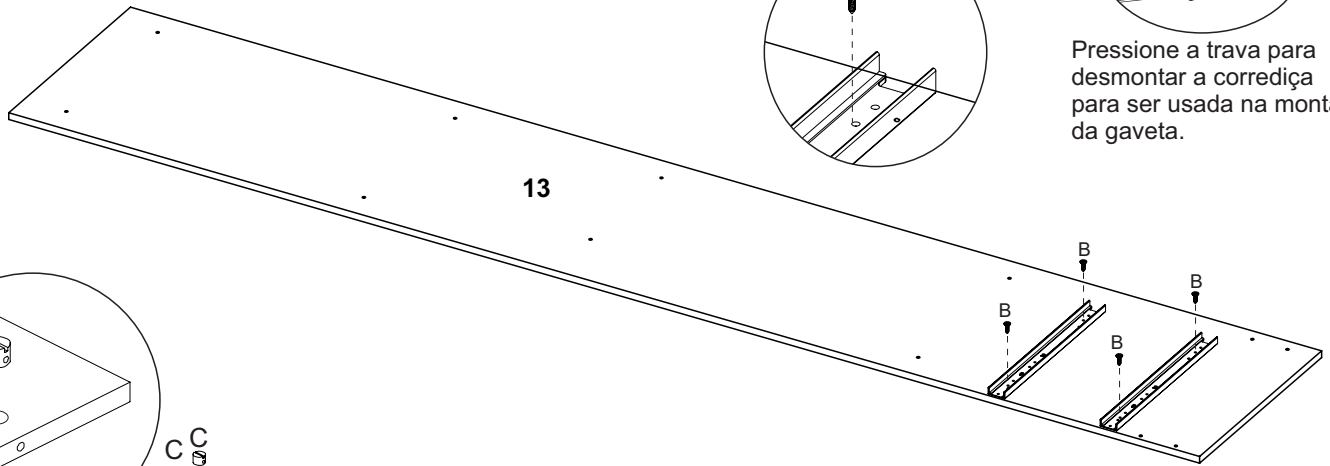

13

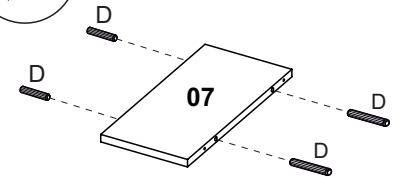
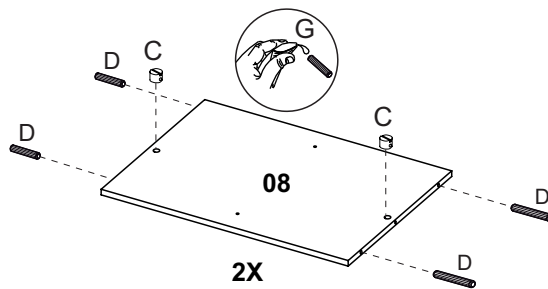
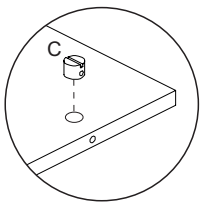
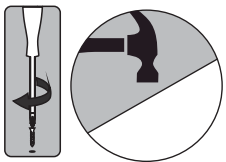
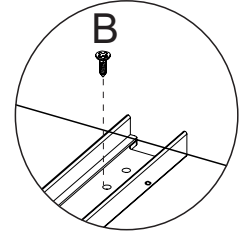
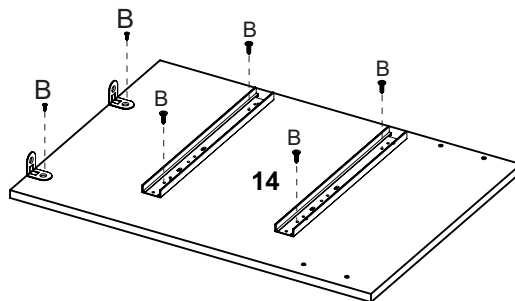
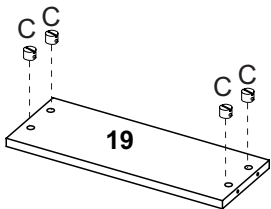
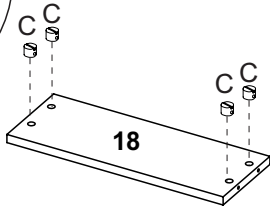
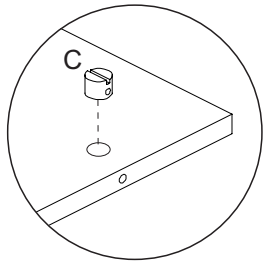

2X

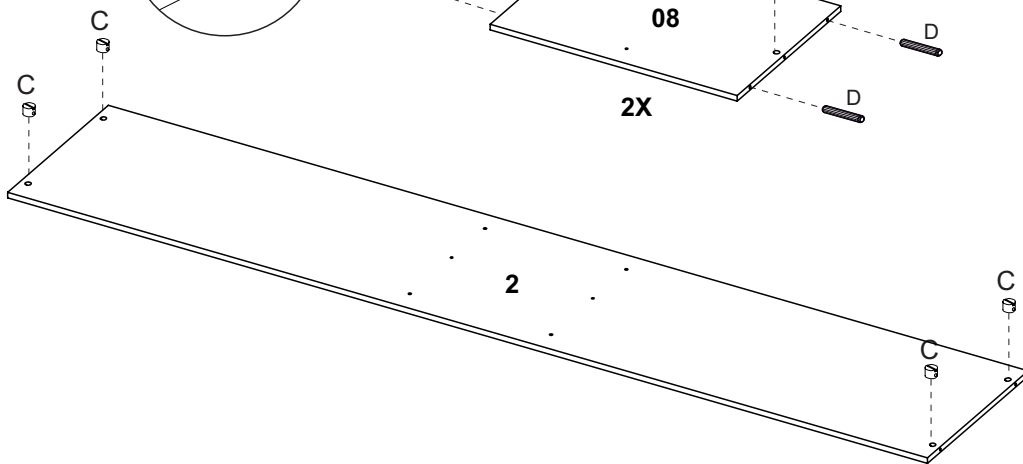

2

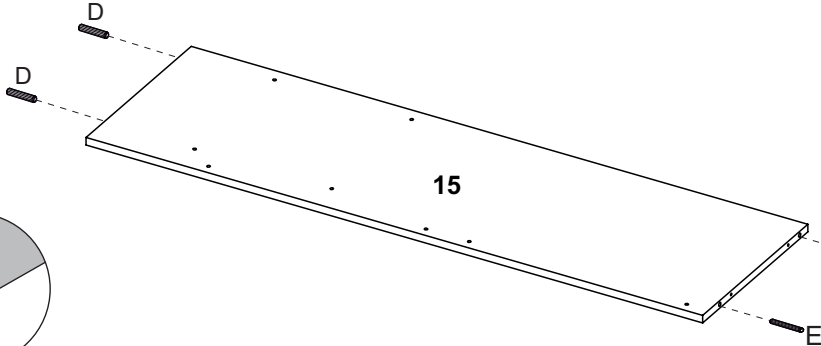

15

Atenção
cavilha
maior E

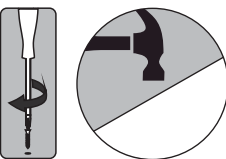

Montagem criado lado esquerdo

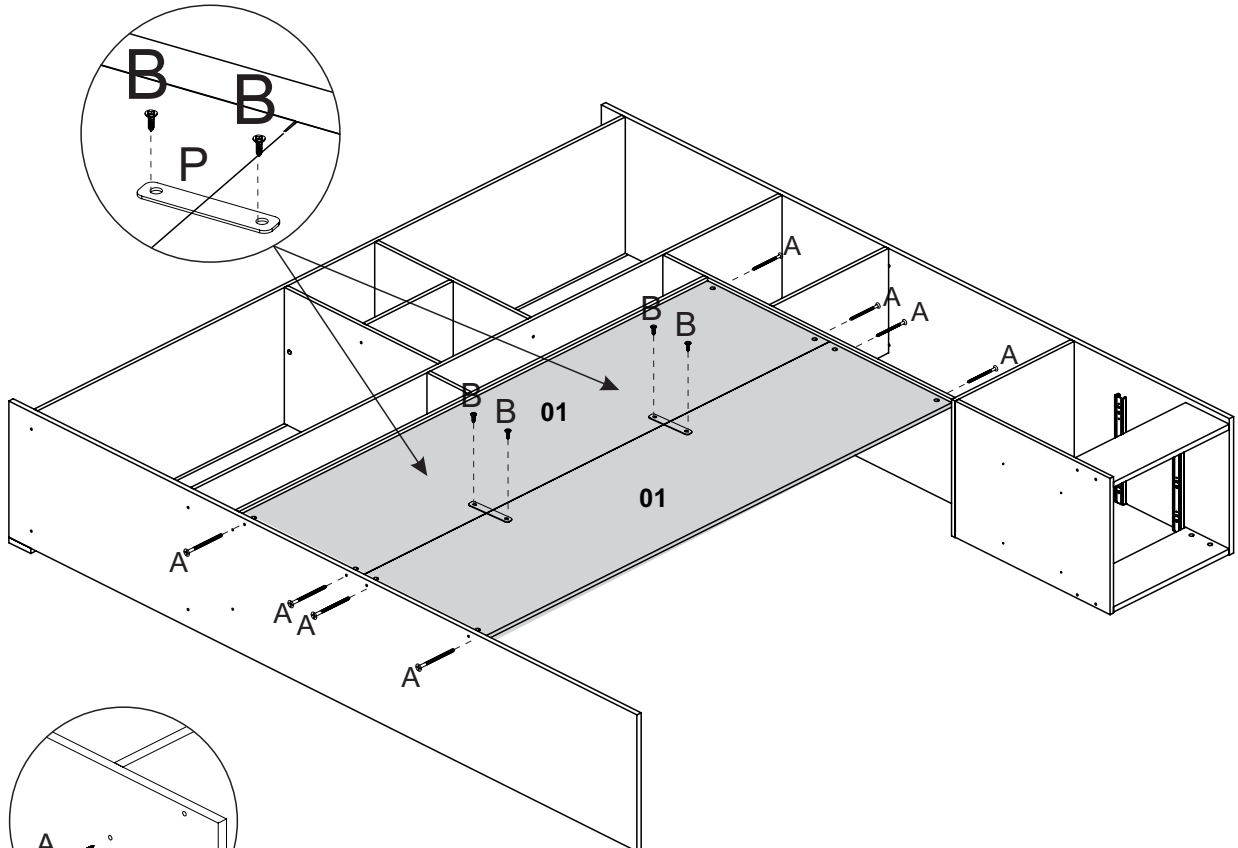
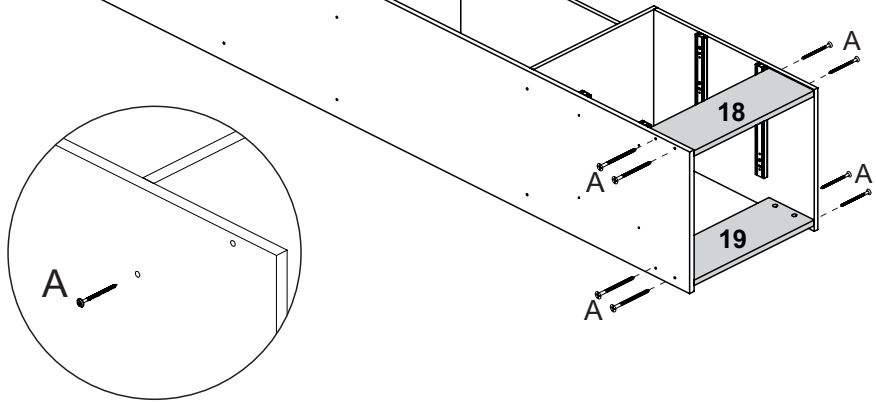
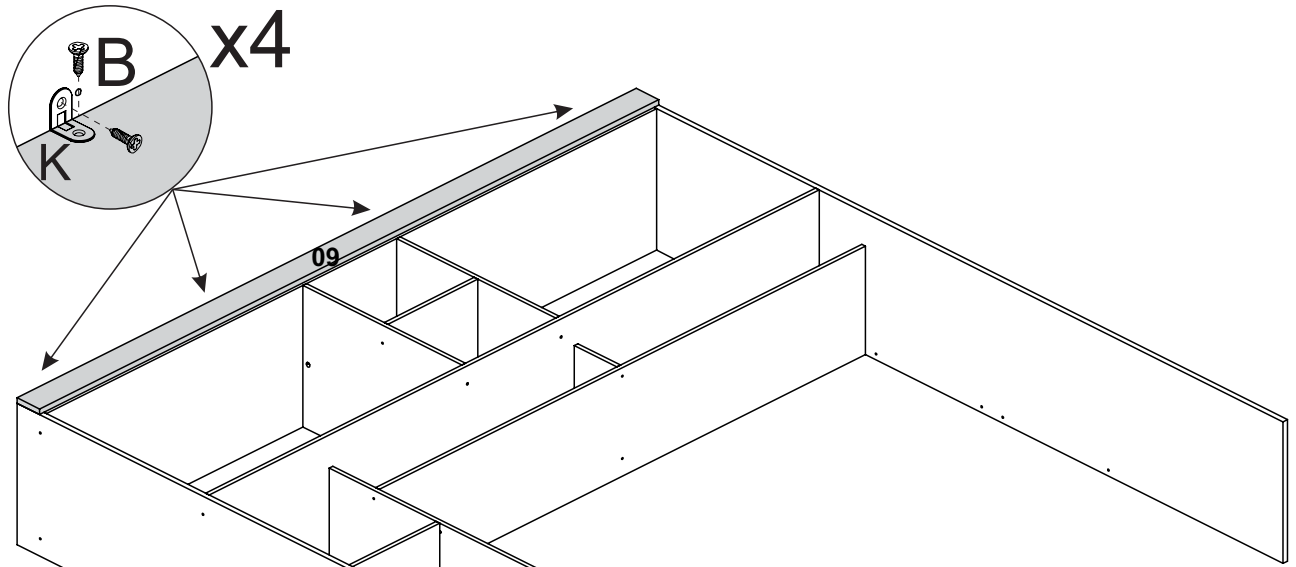

10

Montagem criado lado direito

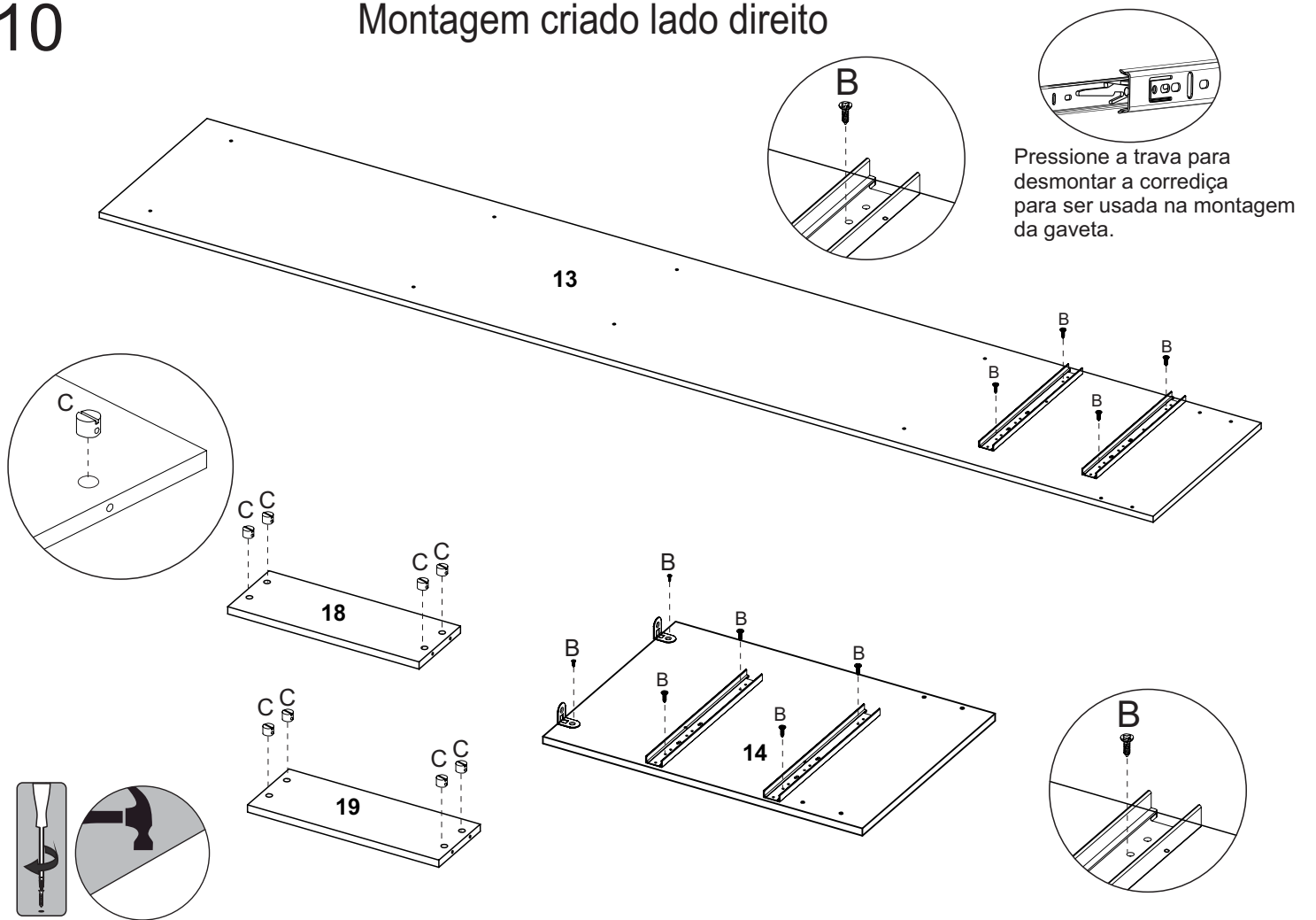

11

Montagem criado lado direito

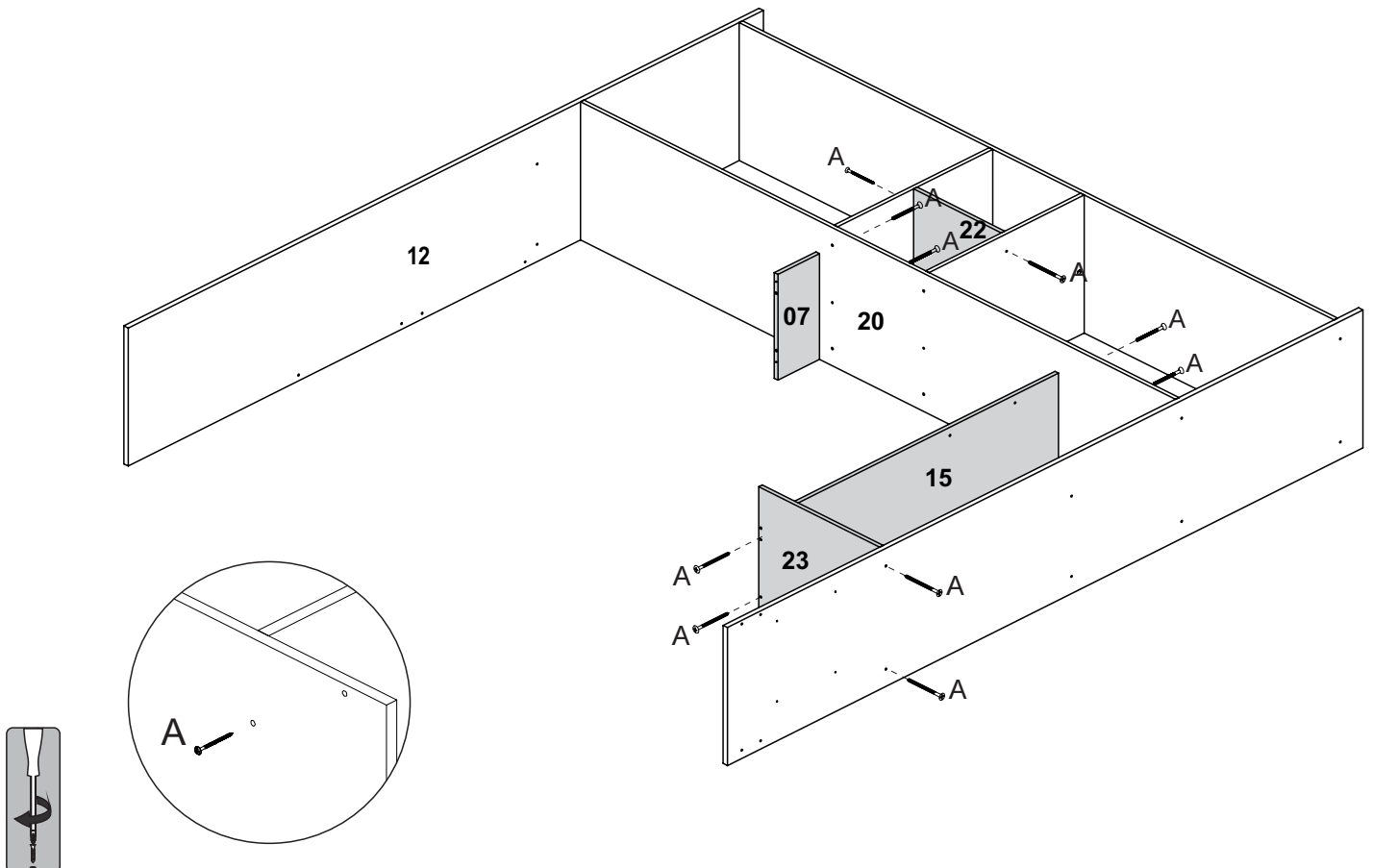

12

Montagem criado lado direito

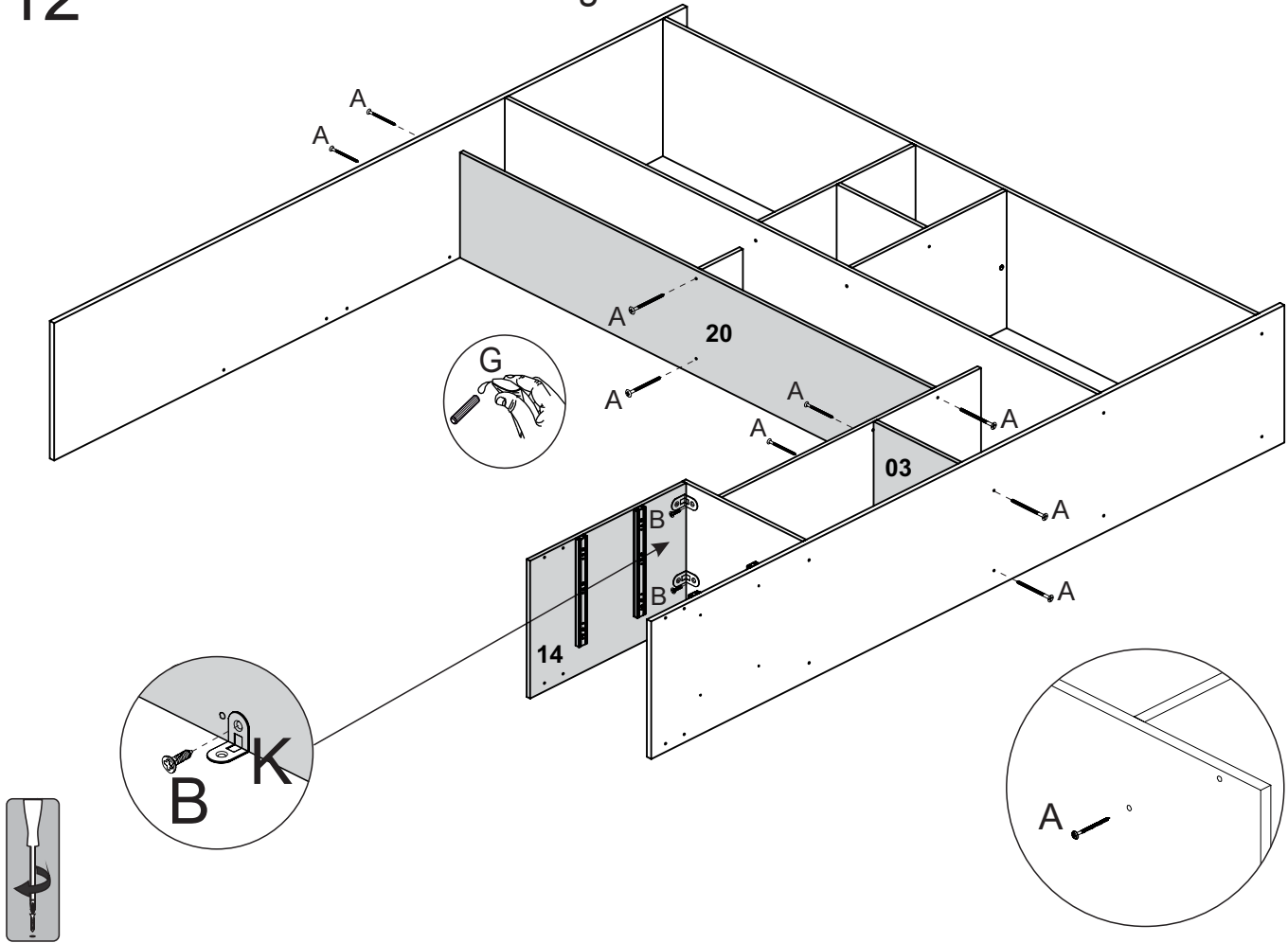

13

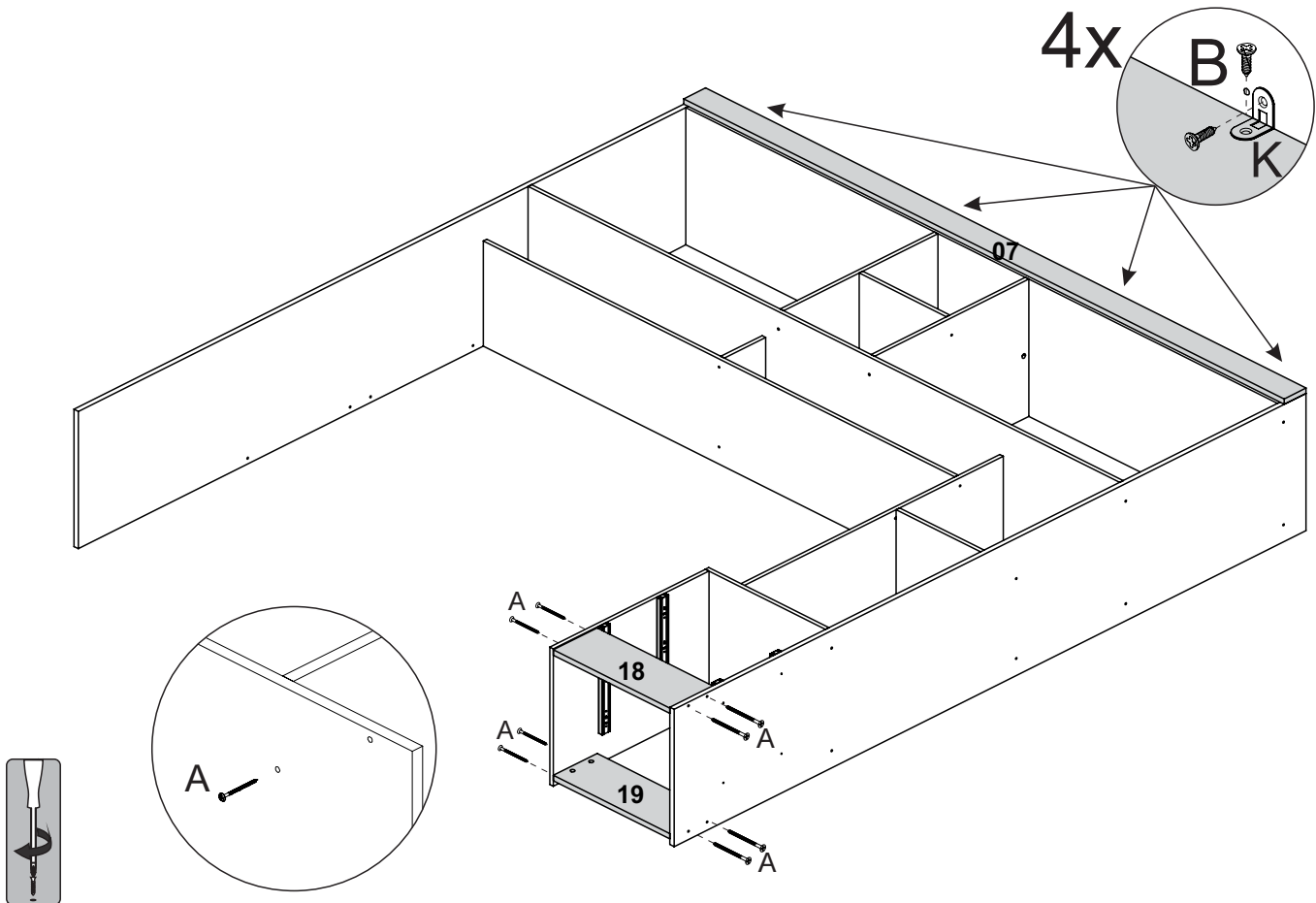

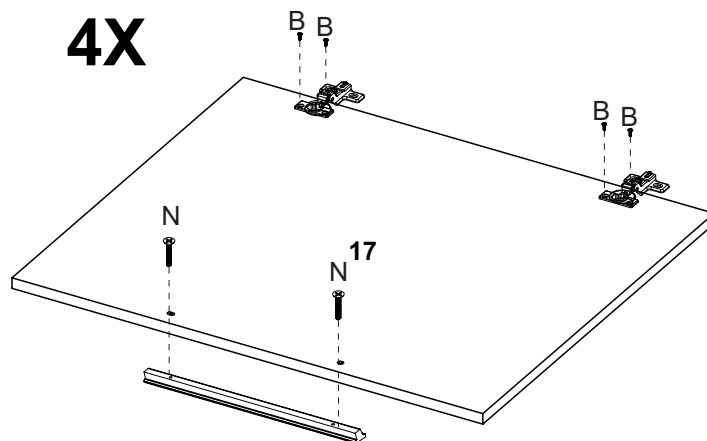
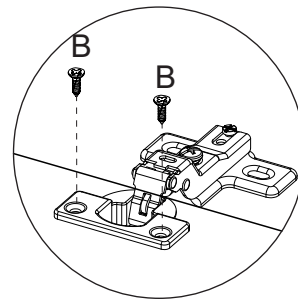
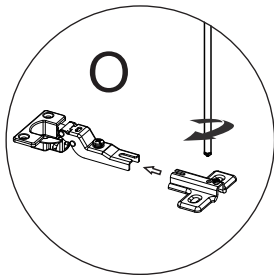
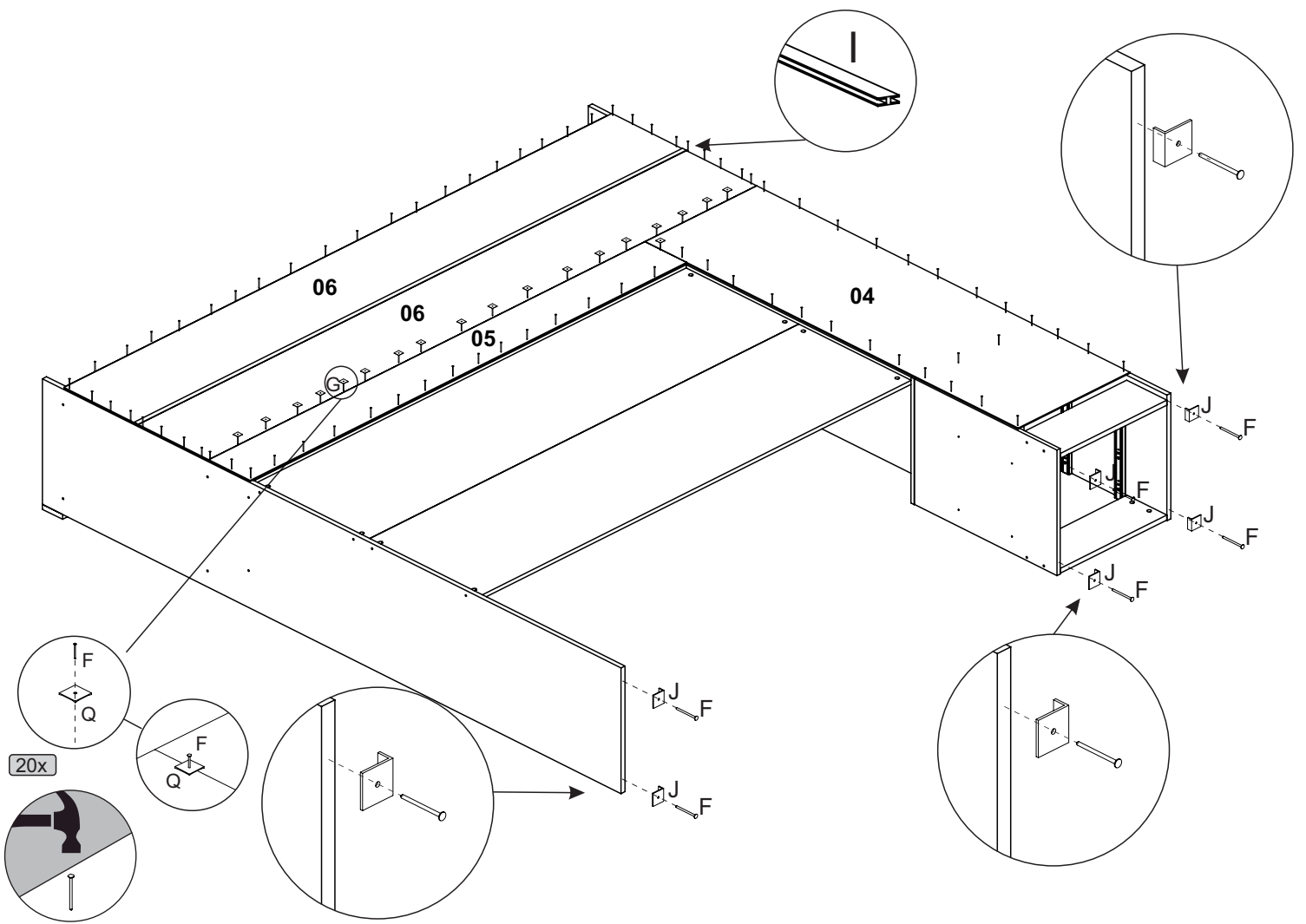

16

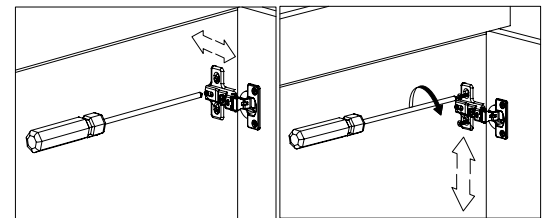
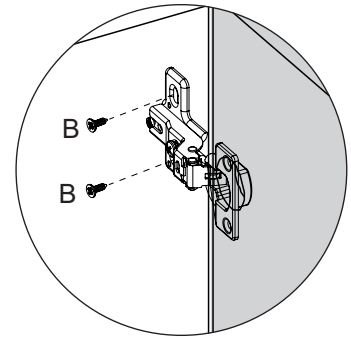
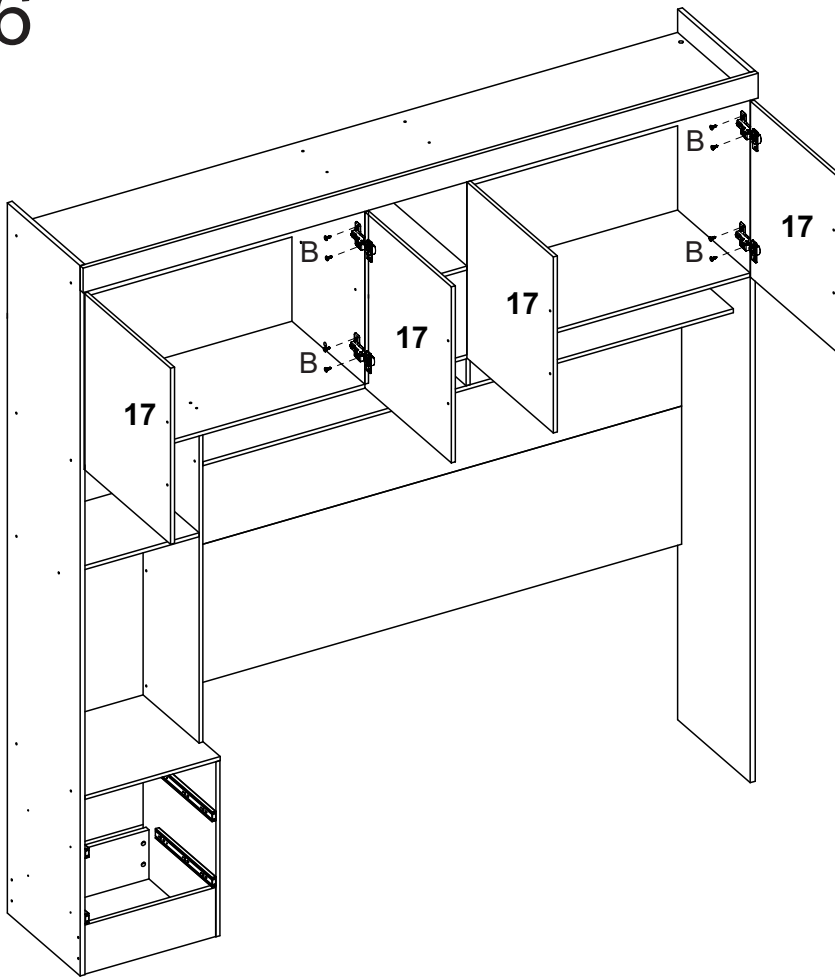

Regulagem da Dobradiça



17

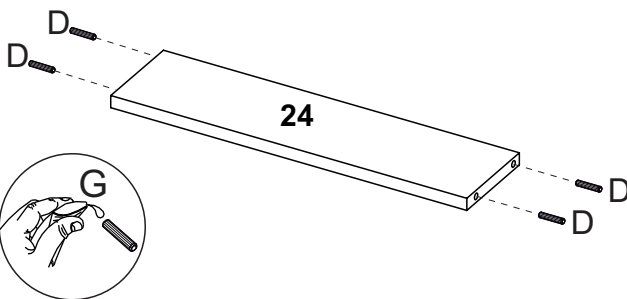
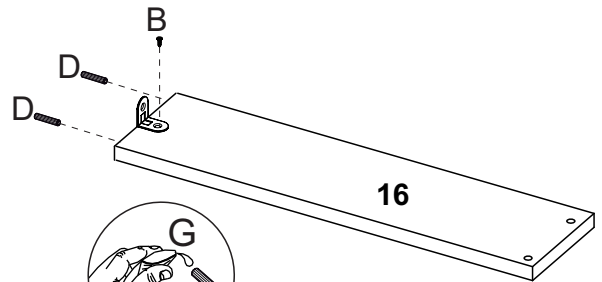
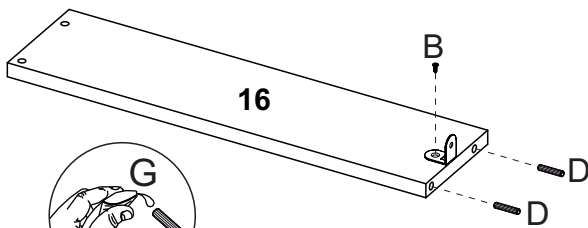

2X

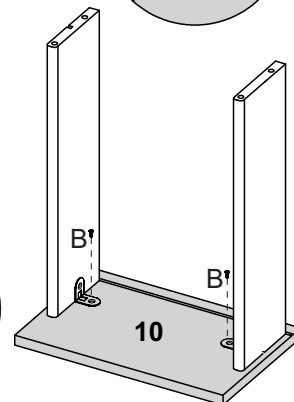
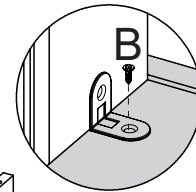

18

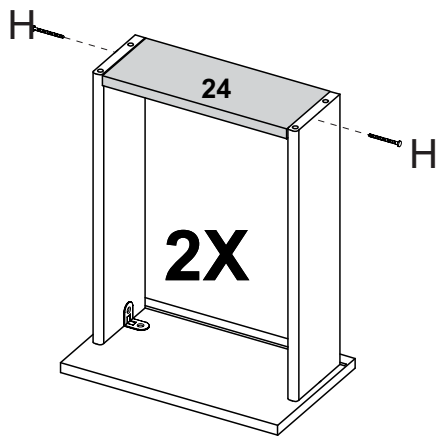

Atenção

Para o bom funcionamento da gaveta muito importante na fixação do fundo da gaveta 09 o mesmo esteja devidamente no esquadro da gaveta conforme a imagem ao lado

2X O fundo da gaveta deve encaixar na ranhura da frente da gaveta.

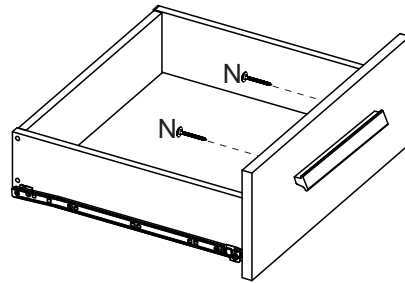
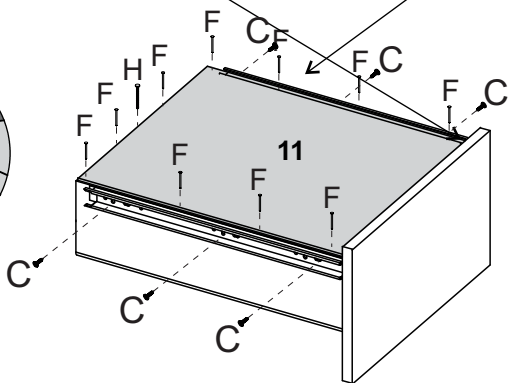
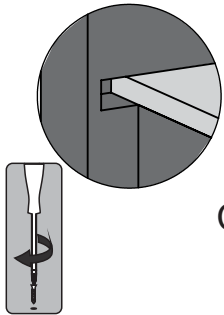
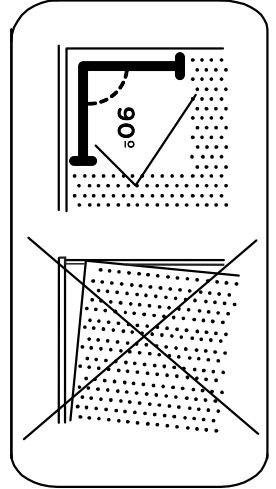
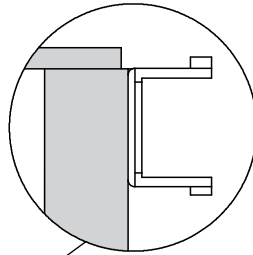

19

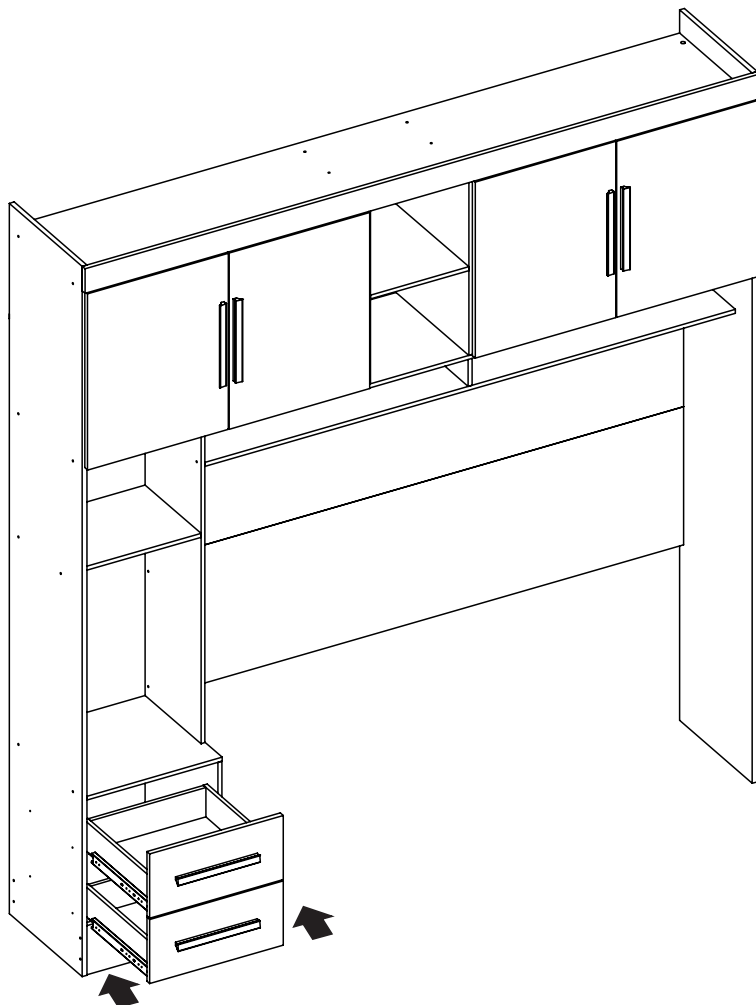

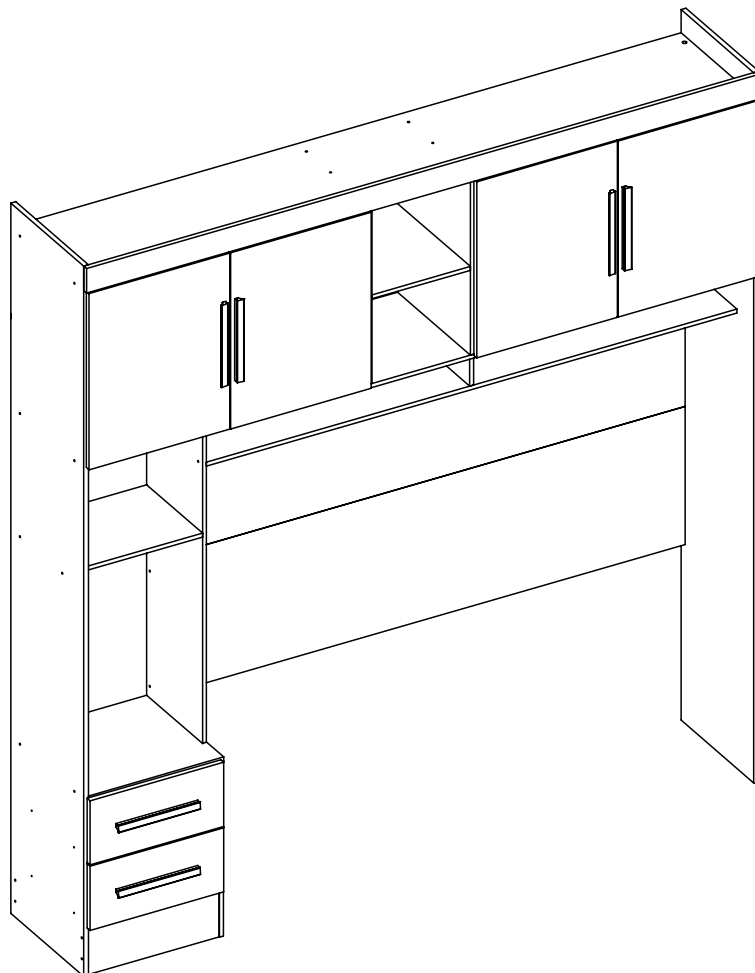
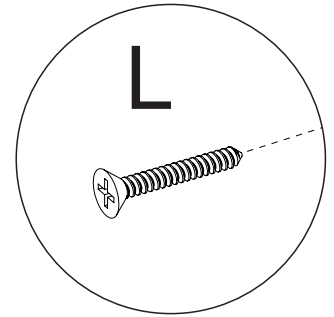
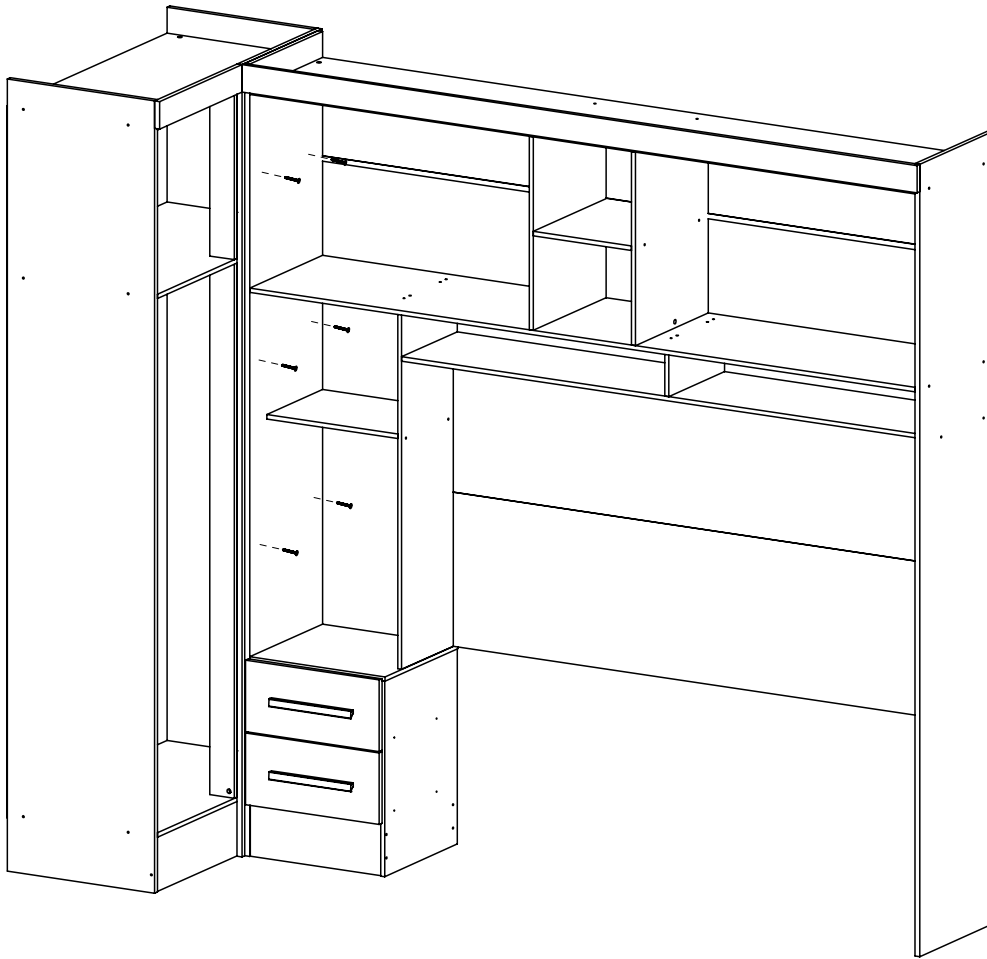

MODULO CANTO SMART GR1010

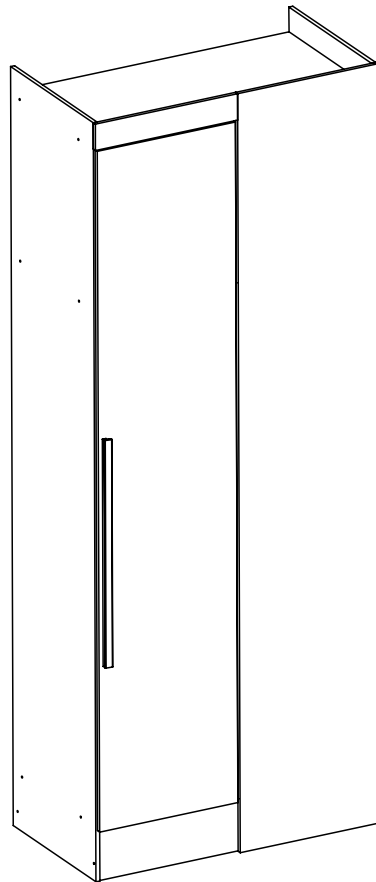

Informações Úteis

É recomendada a prévia leitura de toda a instrução de montagem e conferência das peças e componentes antes de iniciar a montagem do produto.

A montagem do produto deverá ser feita em superfície limpa e plana. Aconselhamos utilizar a embalagem do produto para forrar o chão a fim de não danificar o produto.

Durante a montagem evite batidas e contato com objetos cortantes. Observar as cargas máximas suportado pelo produto.

Limpeza

Retire o pó com uma flanela seca e depois utilize um pano macio umedecido com água.

Não utilizar produtos químicos e abrasivos

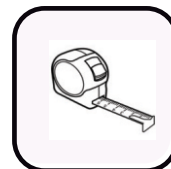
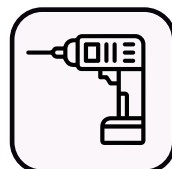

N° DA PEÇA	DESCRIÇÃO	QTD	CÓD. BRANCO	CÓD. CINAMOMO	CÓD. CINAMOMO OFF WHITE	CÓD. CINAMOMO CAPPUCCINO
1	CHAPÉU 830X450X12	3	31144	30769	30769	30769
2	COSTA 1950X422X3	2	32986	32765	32765	32765
3	ENCABEÇAMENTO 430X75X12	1	32988	32767	32767	32767
4	FRONTAL 2170X423X12	1	32992	32772	32772	32772
5	LATERAL 2170X450X12 DIR	1	32999	32776	32776	32776
6	LATERAL 2170X450X12 ESQ	1	32998	32779	32779	32779
7	PILASTRA 1463X75X15	1	31142	30765	30765	30765
8	PILASTRA 450X75X15	1	31143	30766	30766	30766
9	PORTA 1946X418X12	1	33002	32969	32783	32976
10	RODAPÉ FRONTAL 830X150X15	1	30045	30379	30379	30379

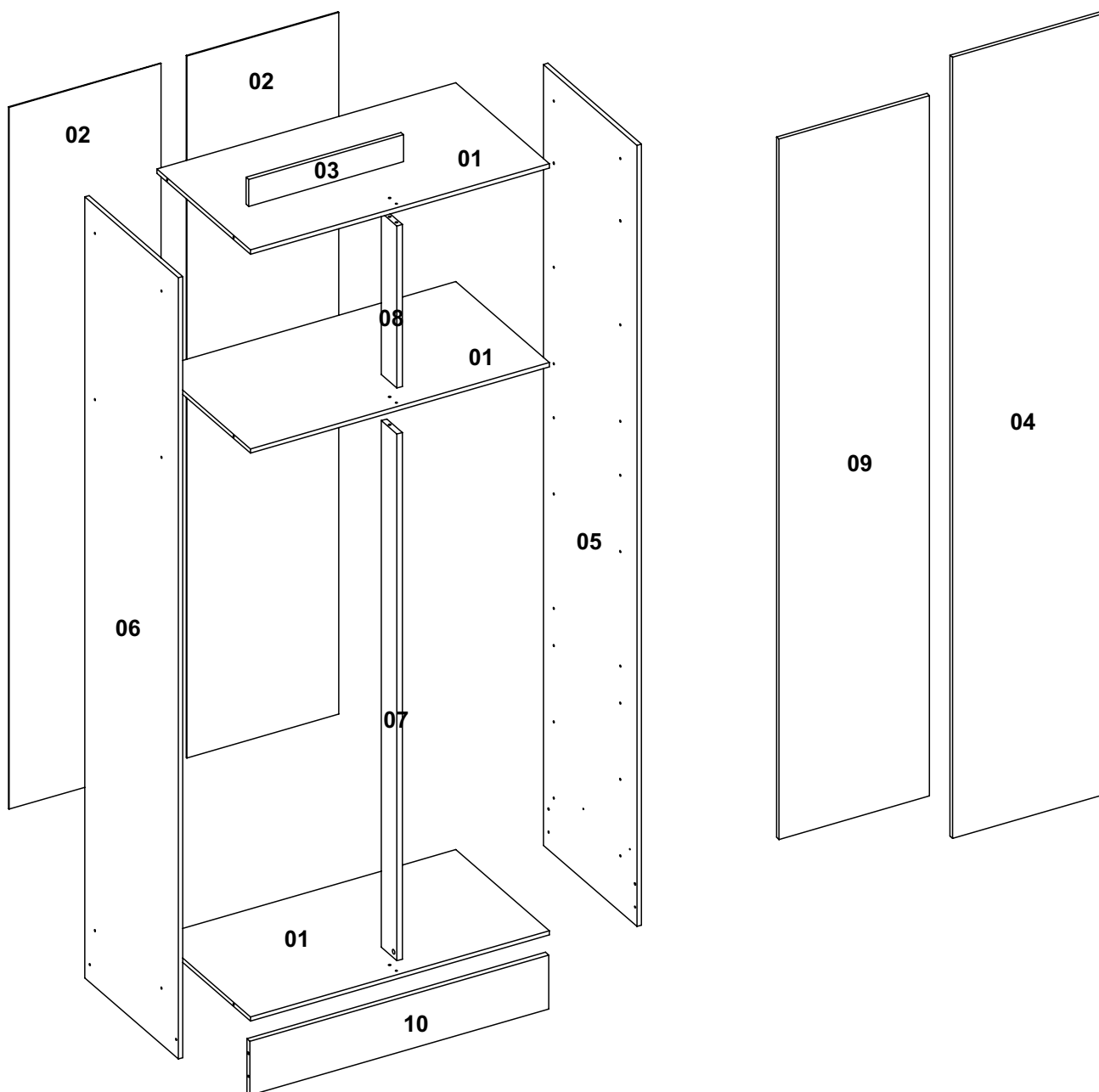

Lista de Ferragens

Parafuso 4,0x40 - Cod.3983

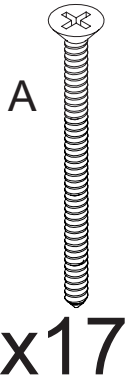

Parafuso 3,5x12 Cód.3385



Porca plástica Cód.29468



Cavilha 6x30 Cód.3881



6x50-Cod 8686

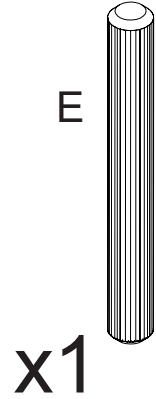

Prego 10x10 Cód.3875

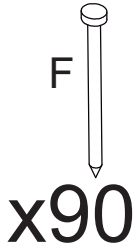

Cod 10865

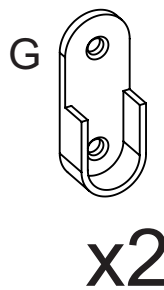

CABIDEIRO

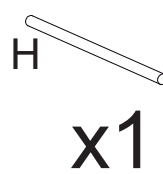

1875mm



Sapata simples Cód.15597



Cod 3882

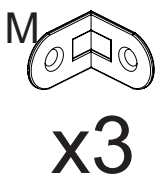

3,5x25-cod 7182

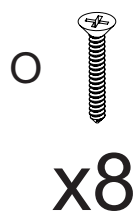

650MM

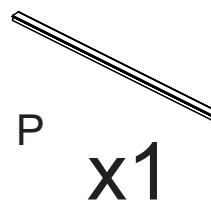

Cantoneira dupla Cód.11409

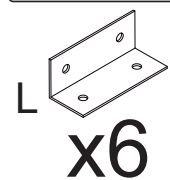

3,5x25-Cod 3870

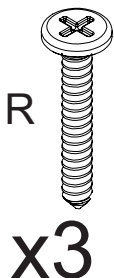

Cod 3384

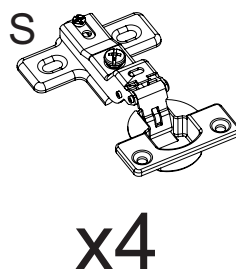

6x20-Cod 26366

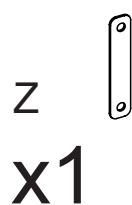

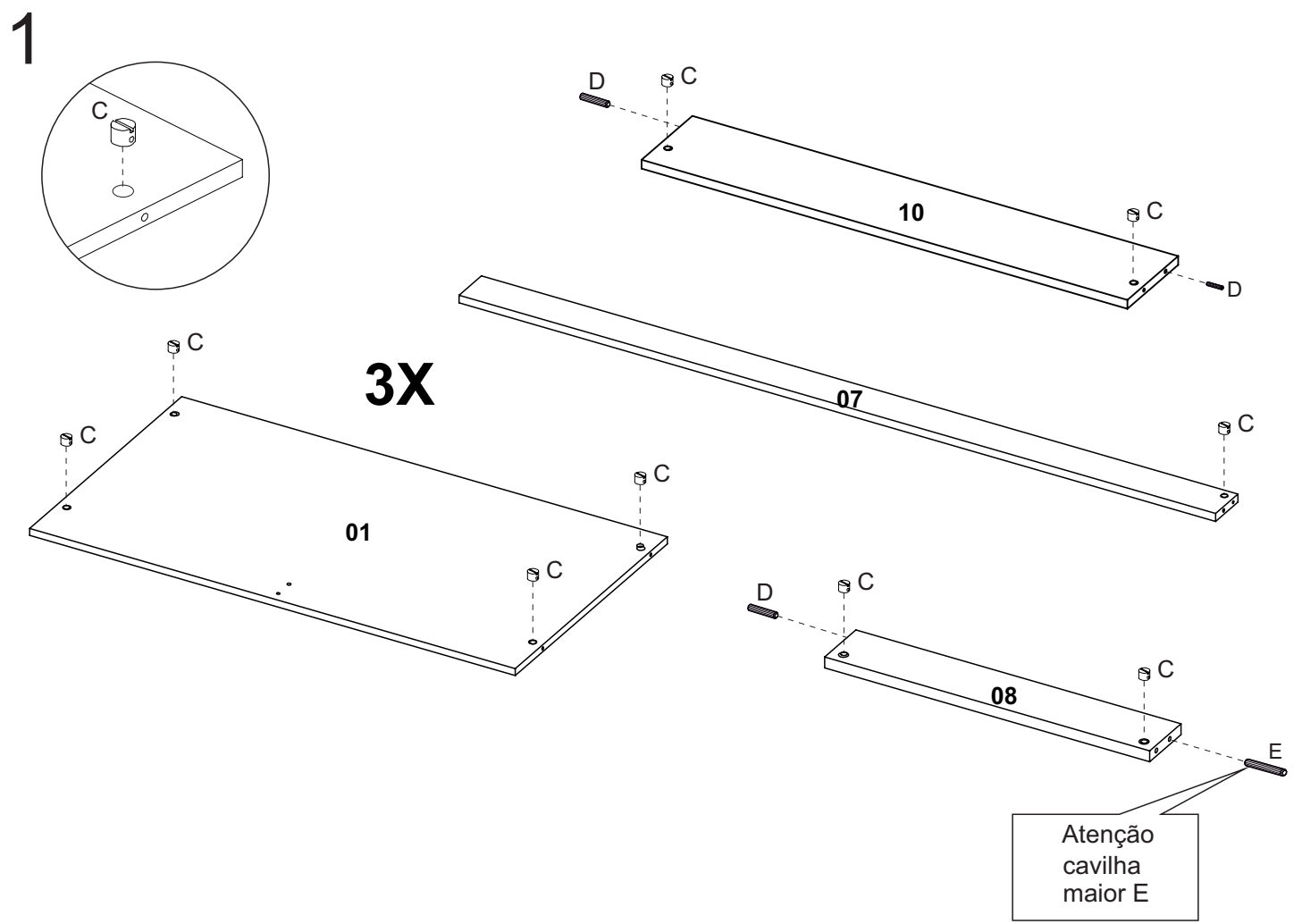
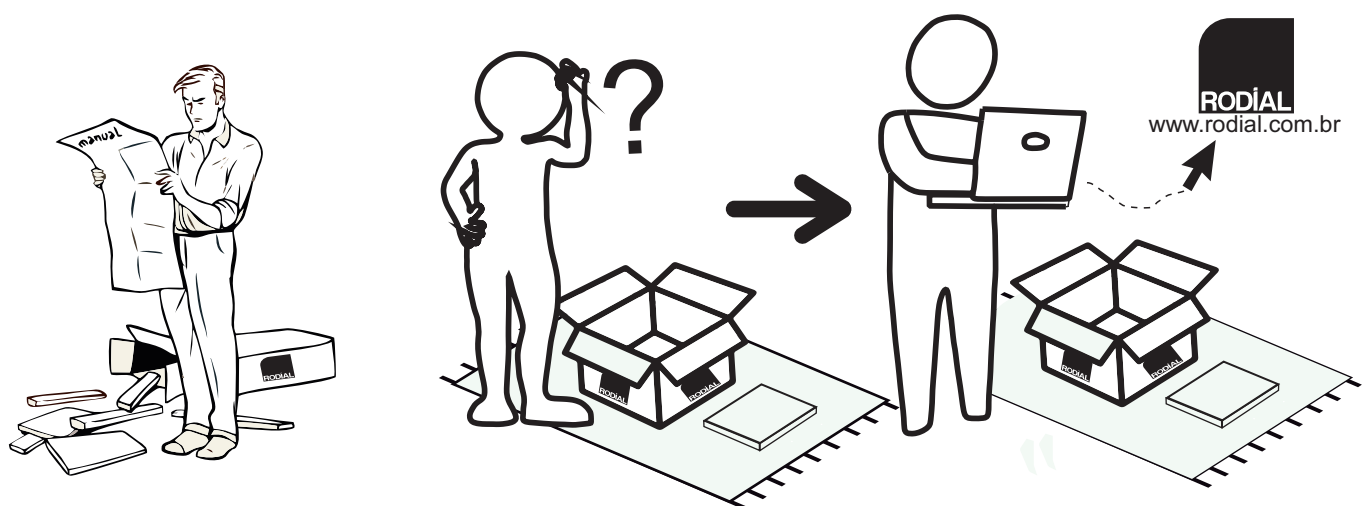
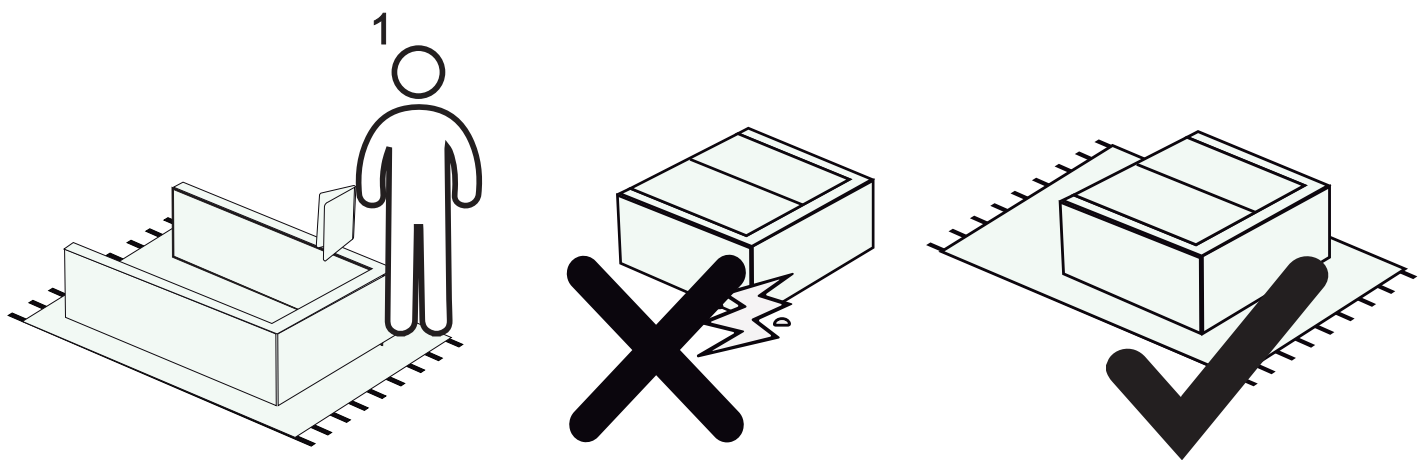

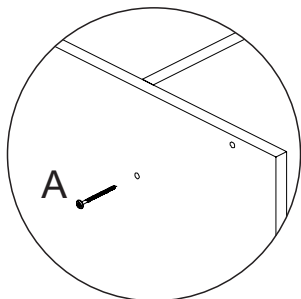
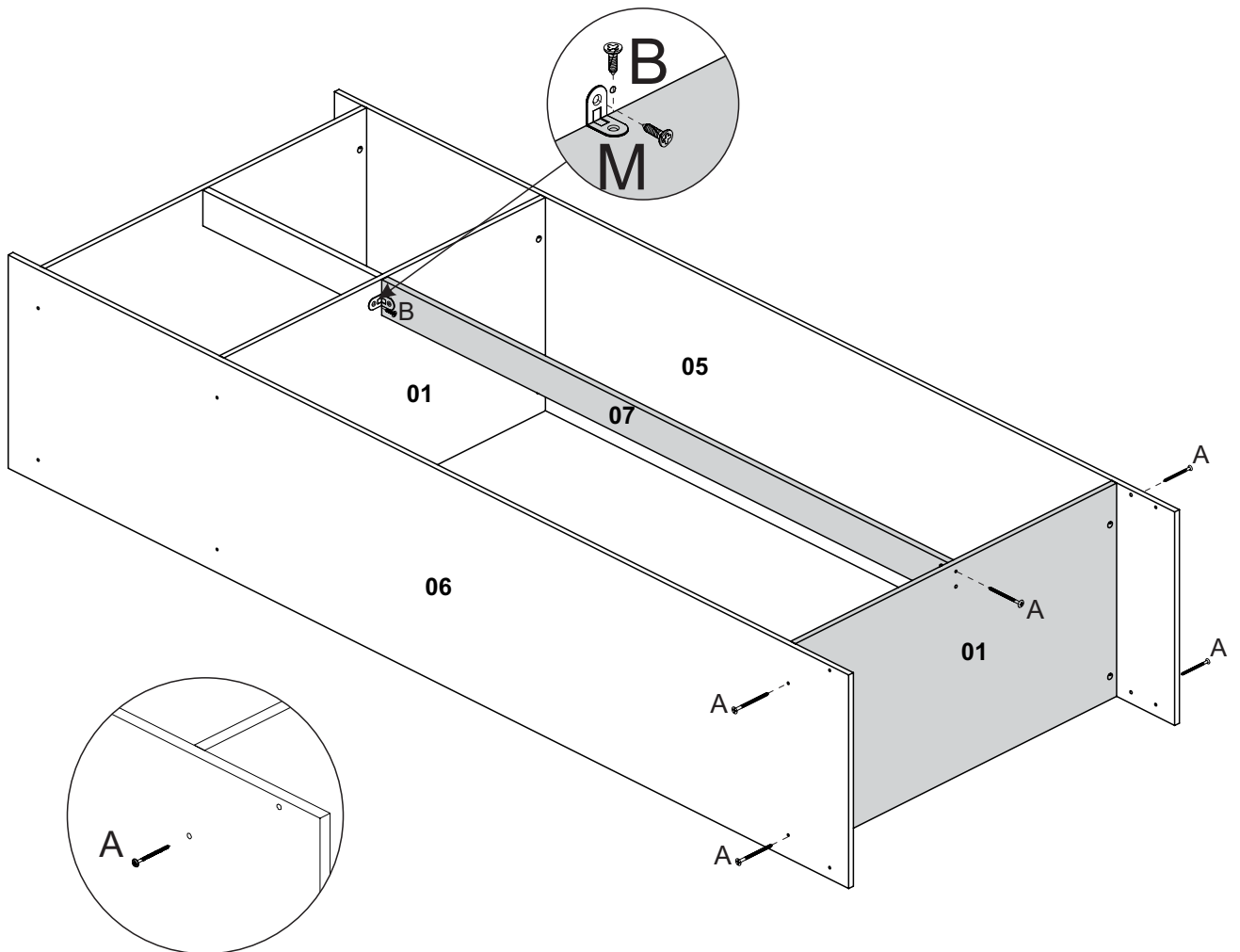
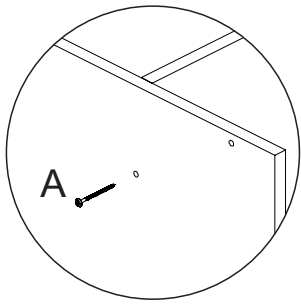
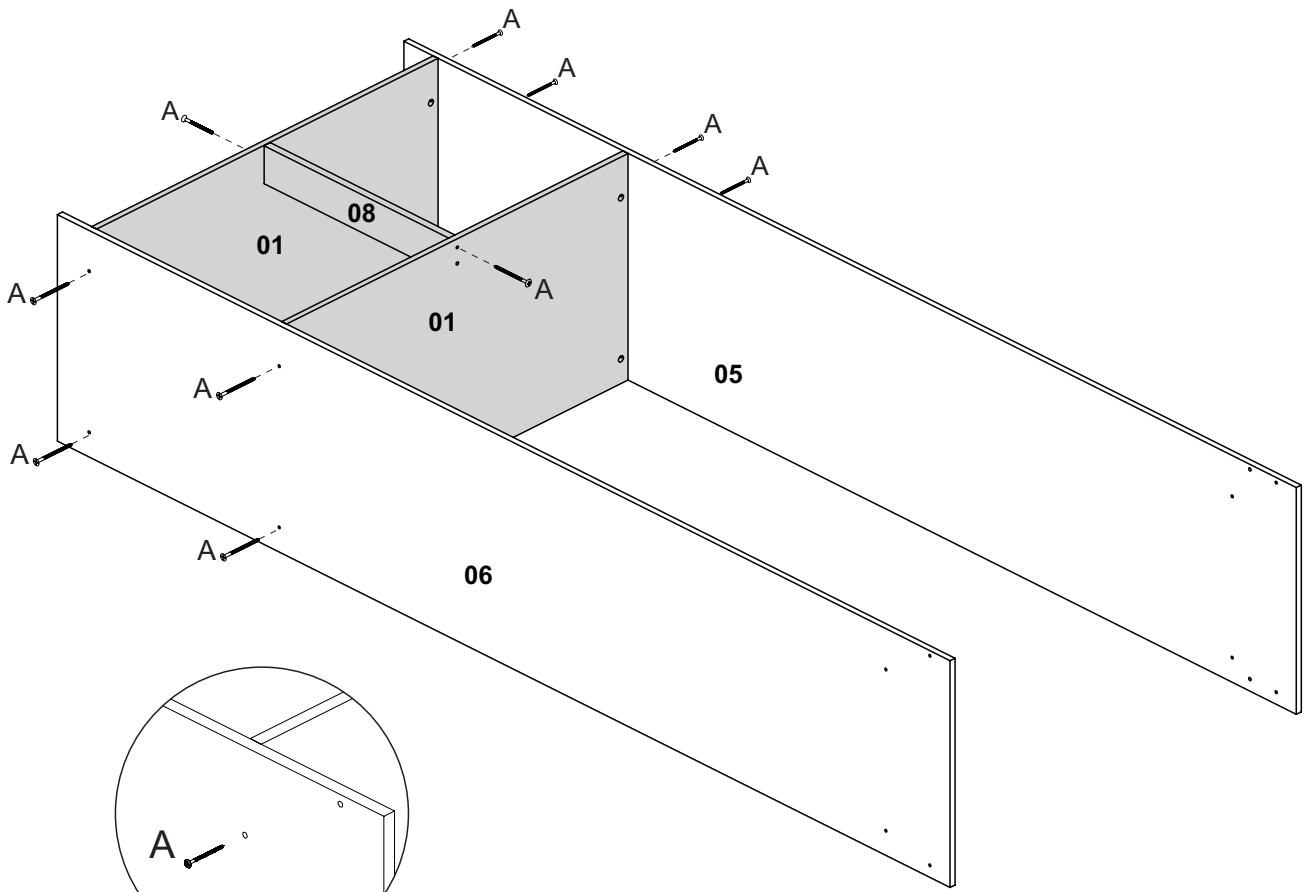

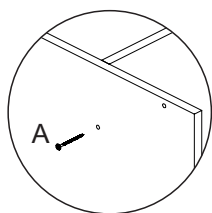
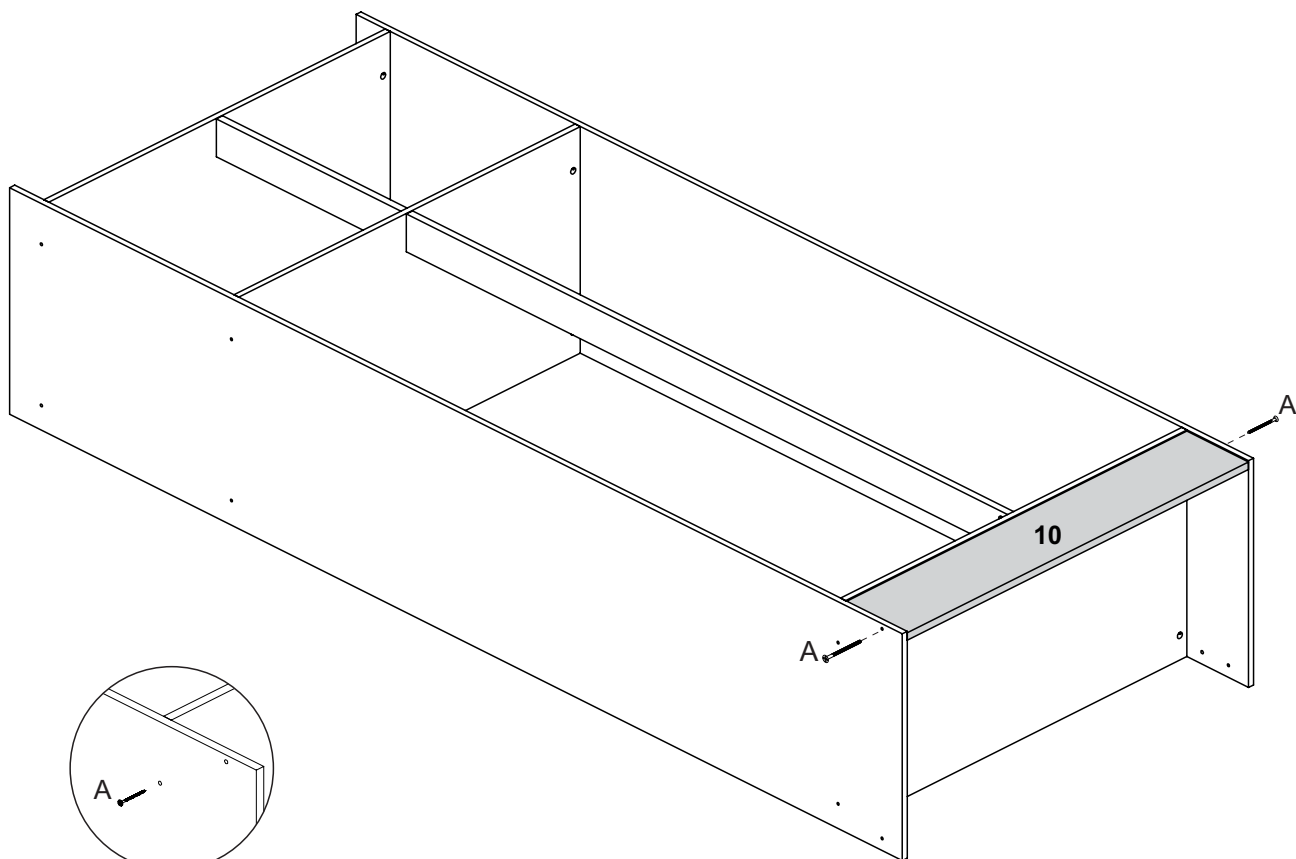

Atenção

Esse produto permite a fixação da porta com abertura para ambos os lados, Observe o melhor lado para a abertura conforme a disponibilização do ambiente antes de fixar o frontal 04.

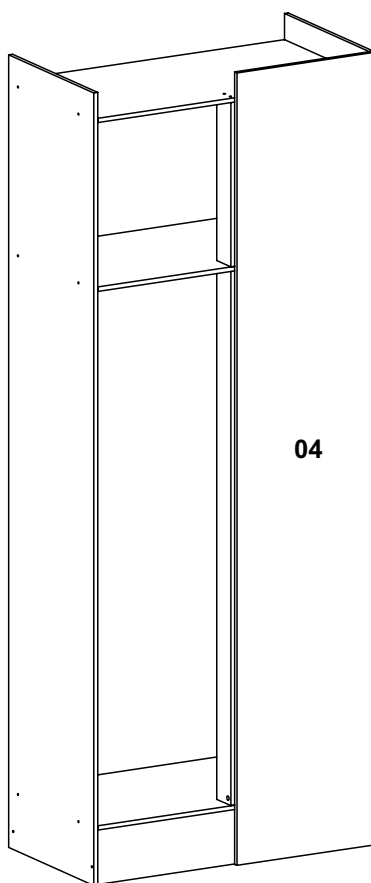
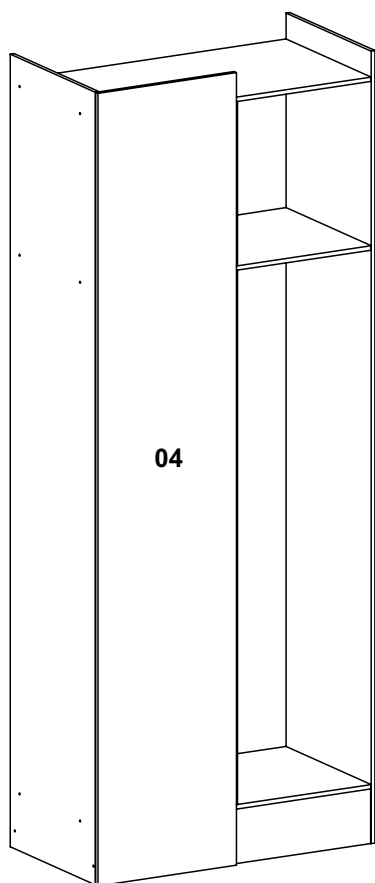

6

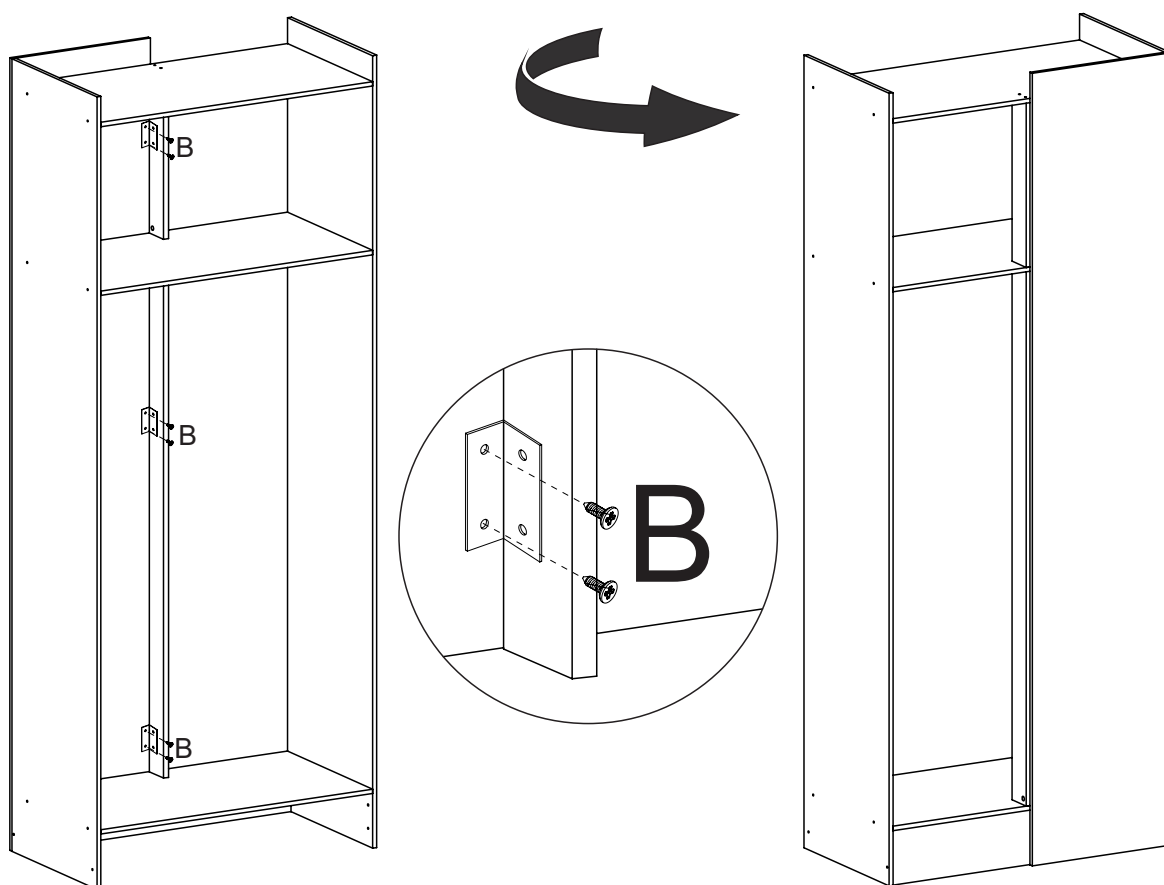
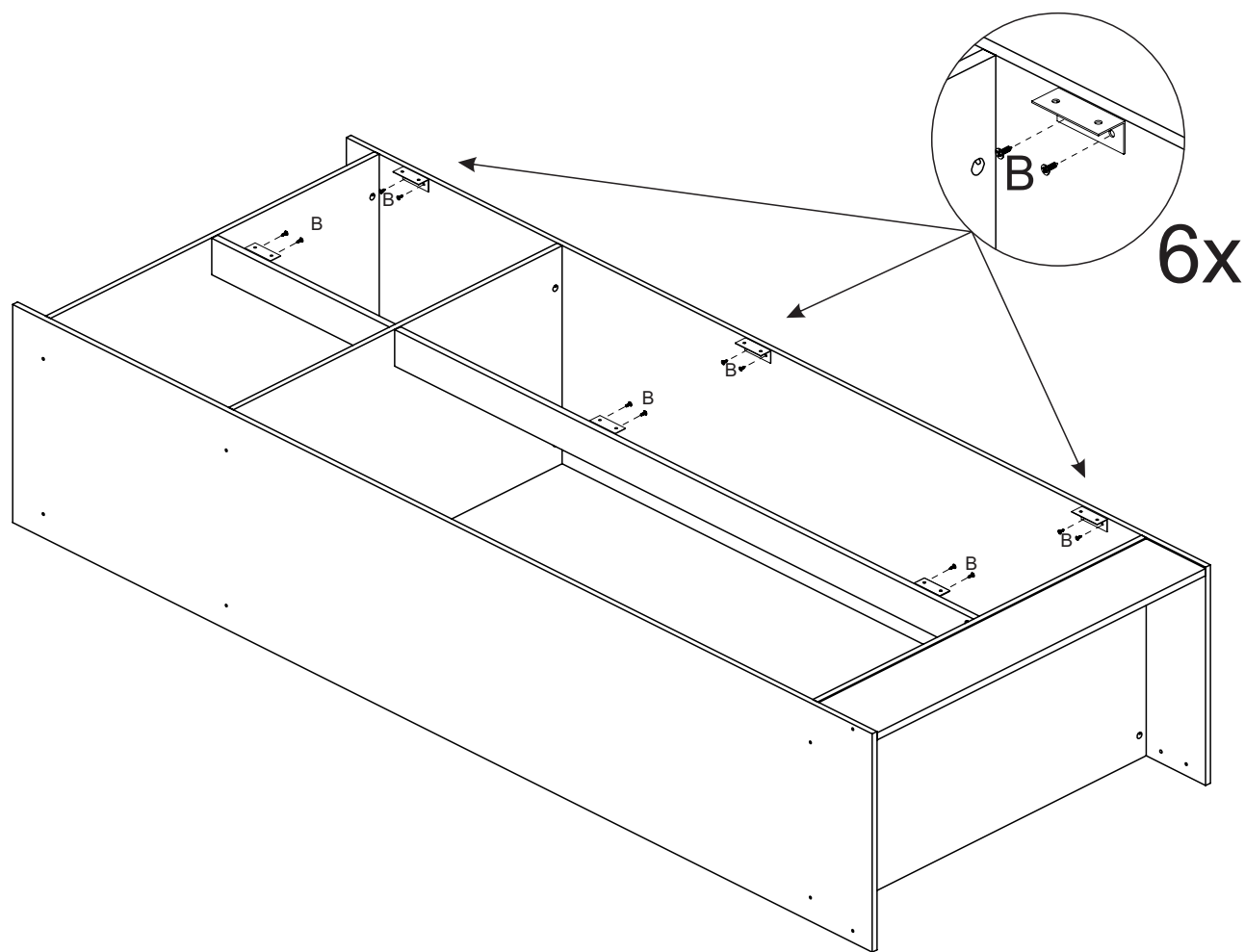

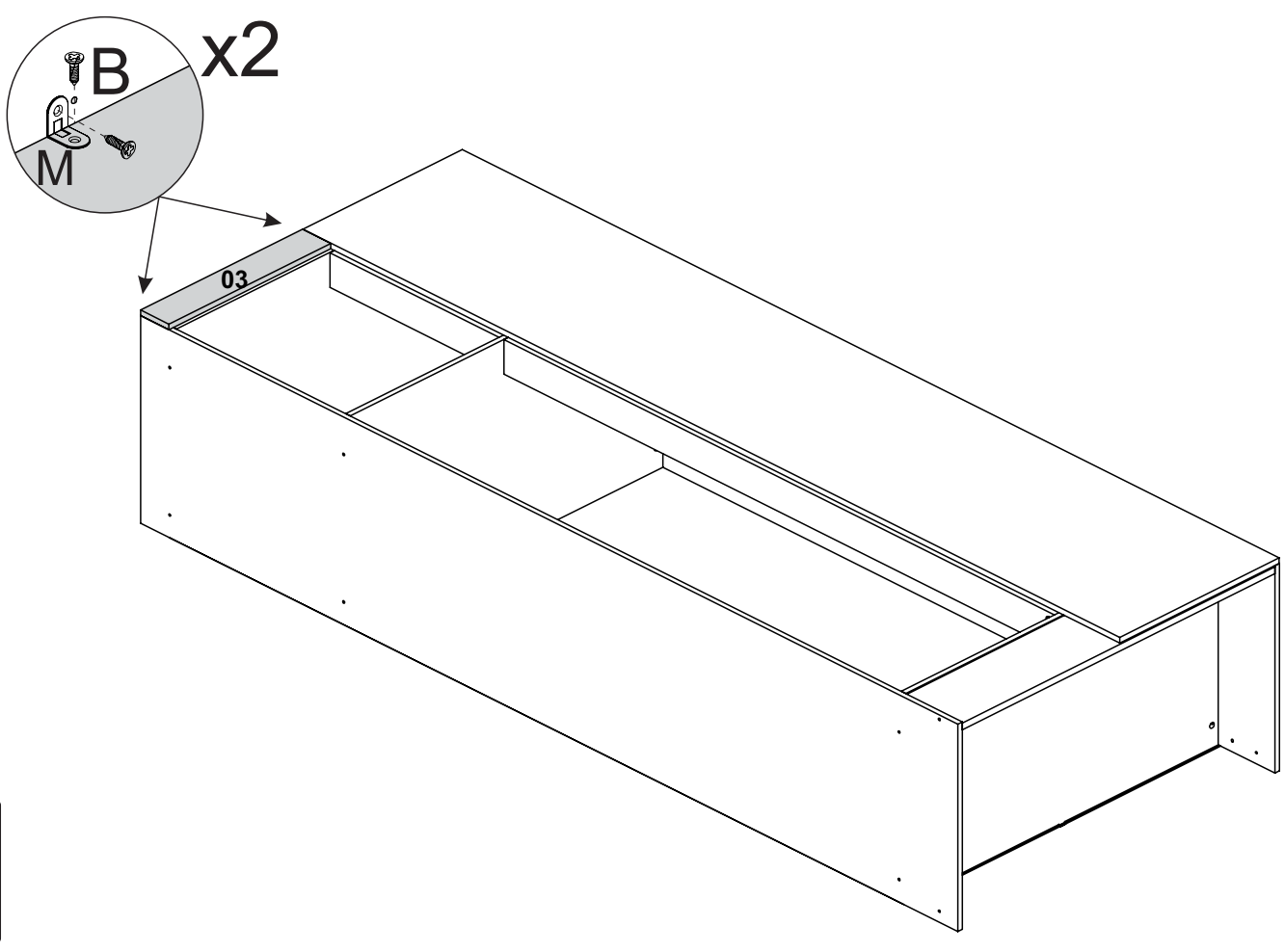
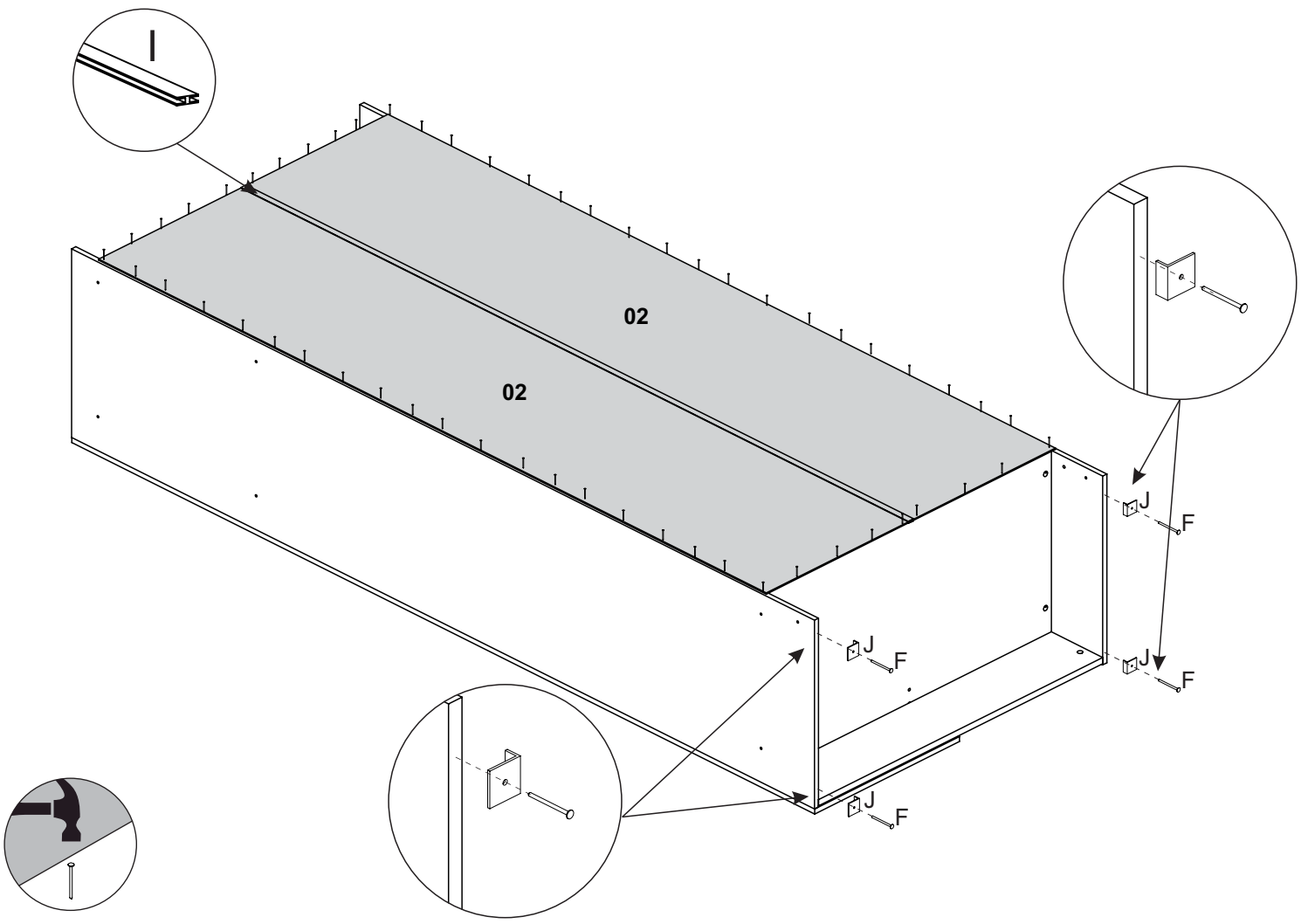

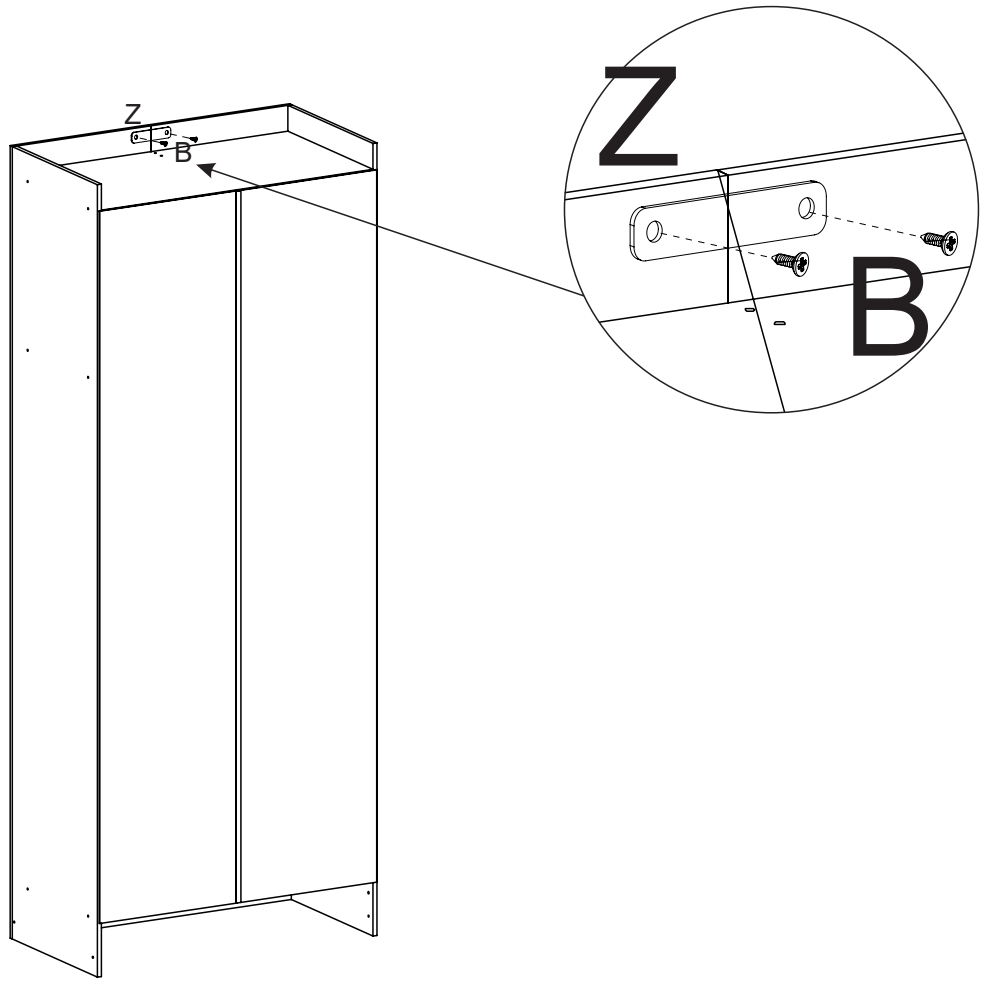

11

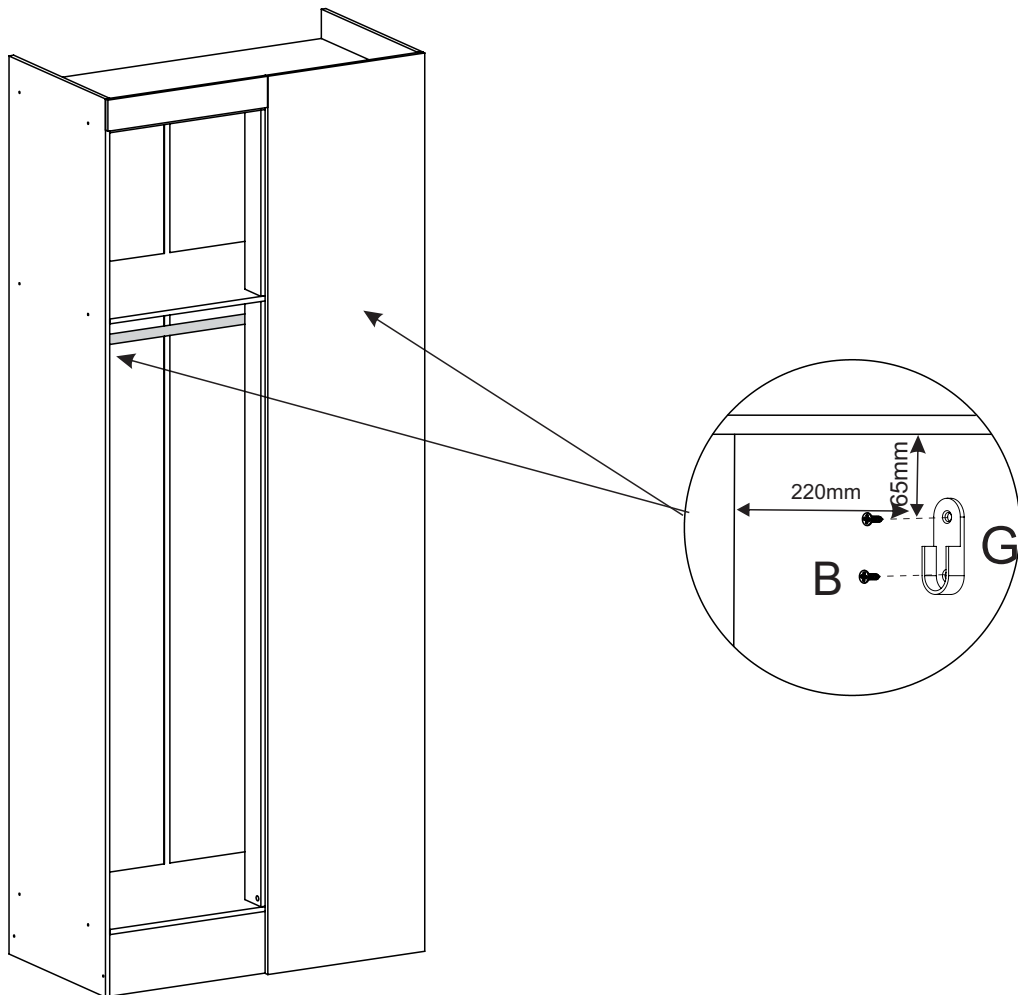

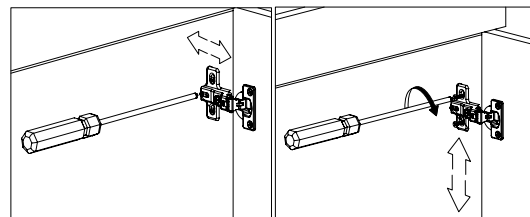
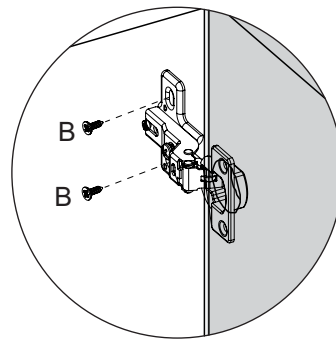
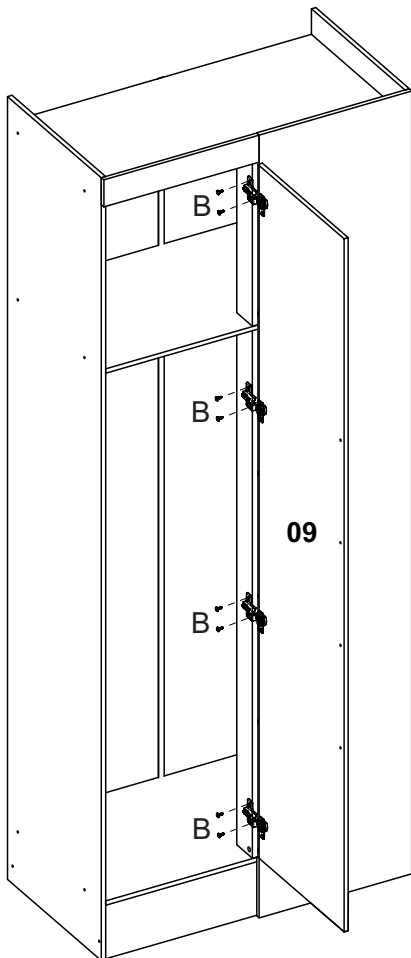
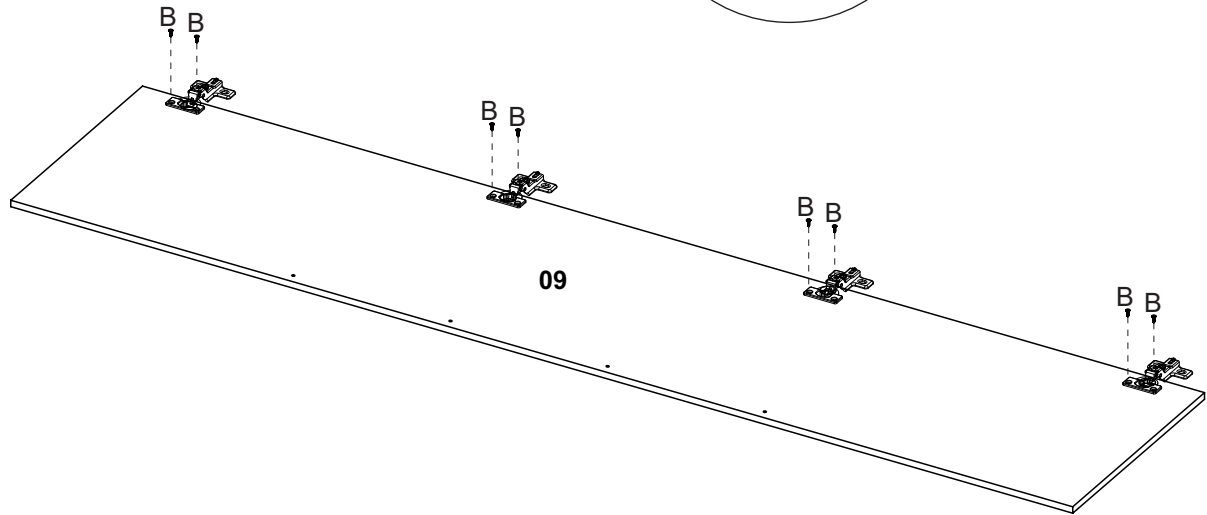
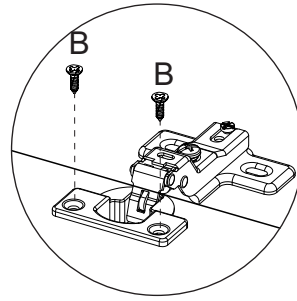
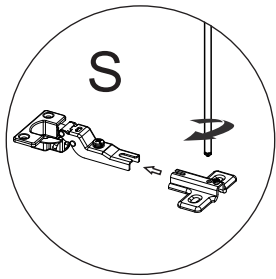

Regulagem da Dobradiça



Atenção
*Observar a
posição correta
do puxador*

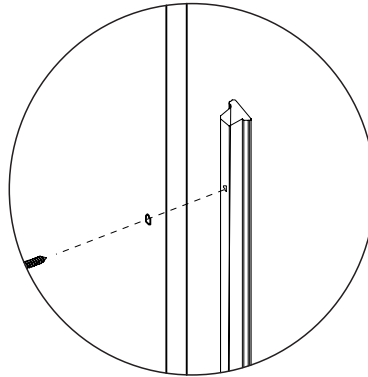
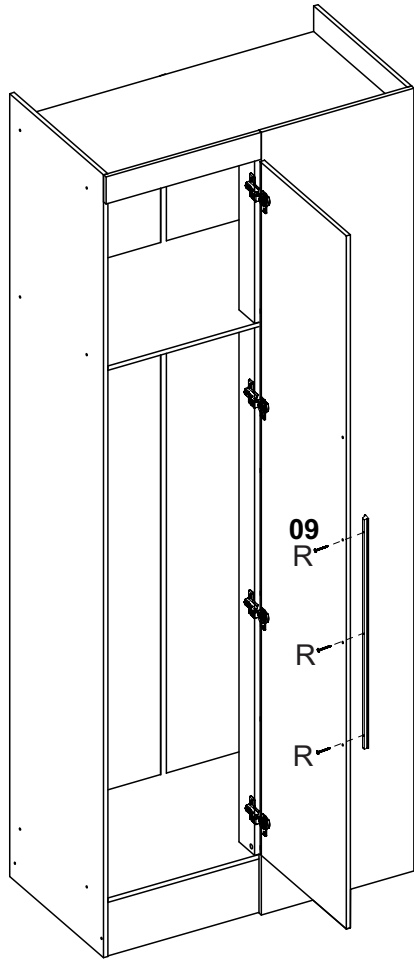

União dos Módulos (opcional)

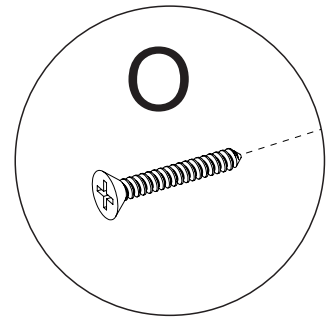
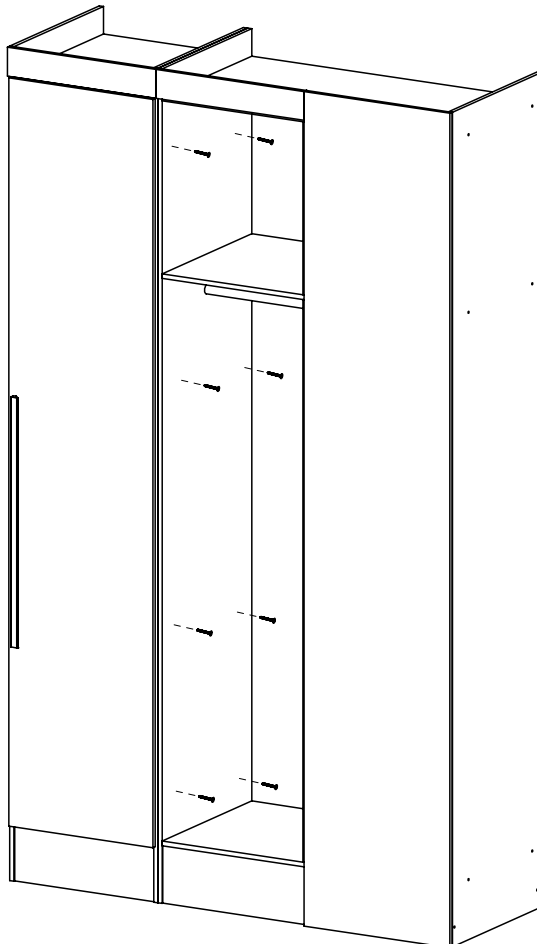

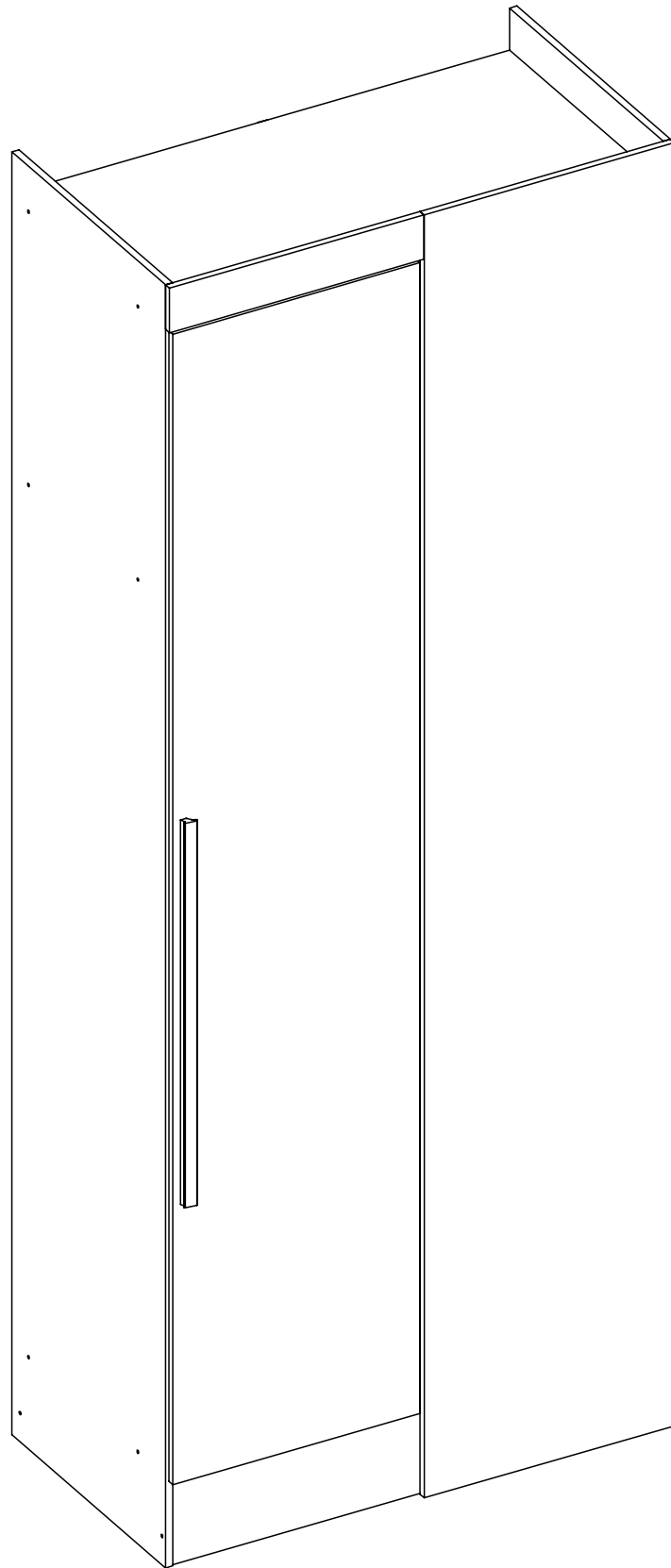

GUARDA ROUPA SEVILHA GR4374M/GR4374ME

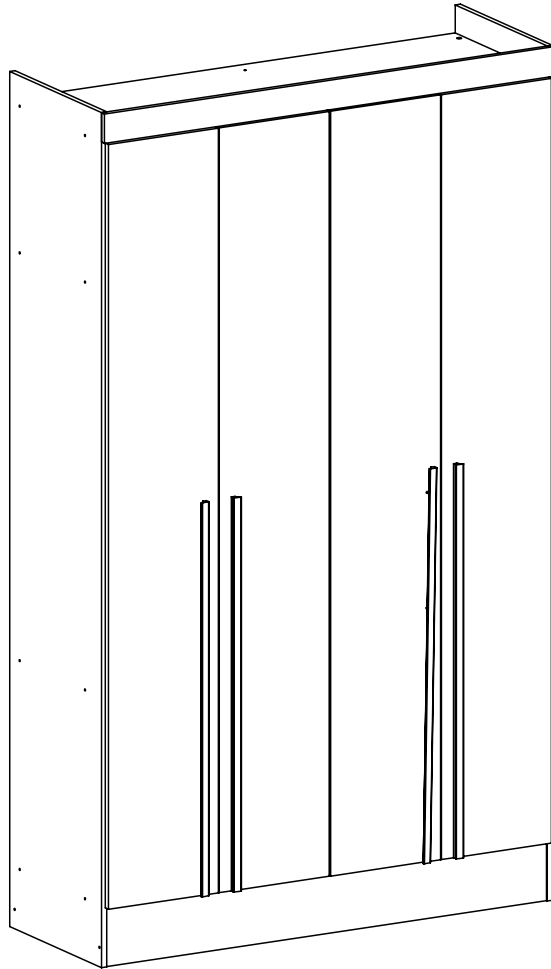

Informações Úteis

É recomendada a prévia leitura de toda a instrução de montagem e conferência das peças e componentes antes de iniciar a montagem do produto.

A montagem do produto deverá ser feita em superfície limpa e plana. Aconselhamos utilizar a embalagem do produto para forrar o chão a fim de não danificar o produto.

Durante a montagem evite batidas e contato com objetos cortantes. Observar as cargas máximas suportado pelo produto.

Limpeza

Retire o pó com uma flanela seca e depois utilize um pano macio umedecido com água.

Não utilizar produtos químicos e abrasivos

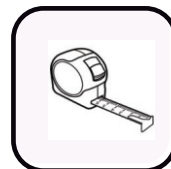
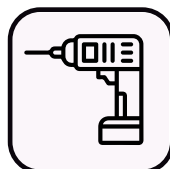

Nº DA PEÇA	DESCRIÇÃO	QTD	BRANCO	CINAMOMO	CINAMOMO OFF WHITE	CINAMOMO CAPPUCCINO
1	CHAPÉU 1246X450X12	2	33282	32828	32828	32828
2	CHAPÉU 617X450X12	1	33324	33323	33323	33323
3	COSTA 1945X630X3	2	35138	34836	34836	34836
4	DIVISÃO 1553X450X12 DIR	1	35081	34705	34705	34705
5	ENCABEÇAMENTO 1276X75X15	1	33319	32850	32850	32850
6	FRENTE GAVETA 562X150X15	3	35095	34706	34706	34706
7	FUNDO DE GAVETA 540X363X3	3	35143	34863	34863	34863
8	LATERAL 2170X450X15 DIR	1	35109	34702	34702	34702
9	LATERAL 2170X450X15 ESQ	1	35108	30703	34703	34703
10	LATERAL DE GAVETA 360X90X12	6	28405	30352	30352	30352
11	PILASTRA 360X90X12	1	33805	31055	31055	31055
12	PORTA 1941X311X15 DIREITA	2	35113	34900	34709	34807
13	PORTA 1941X311X15 ESQUERDA	2	35114	34899	34708	34809
14	PRATELEIRA 617X385X12	2	29389	30344	30344	30344
15	RODAPÉ FRONTAL 1246X150X15	1	29392	32849	32849	32849
16	RODAPÉ TRASEIRO 1246X150X15	1	29393	29393	29393	29393
17	TRASEIRO DE GAVETA 518X90X12	3	33286	32830	32830	32830
18	TRAVESSA 401X150X15	1	23736	23736	23736	23736
19	CHAPÉU 1246X450X12 2 LADOS	1	33321	32851	32851	32851

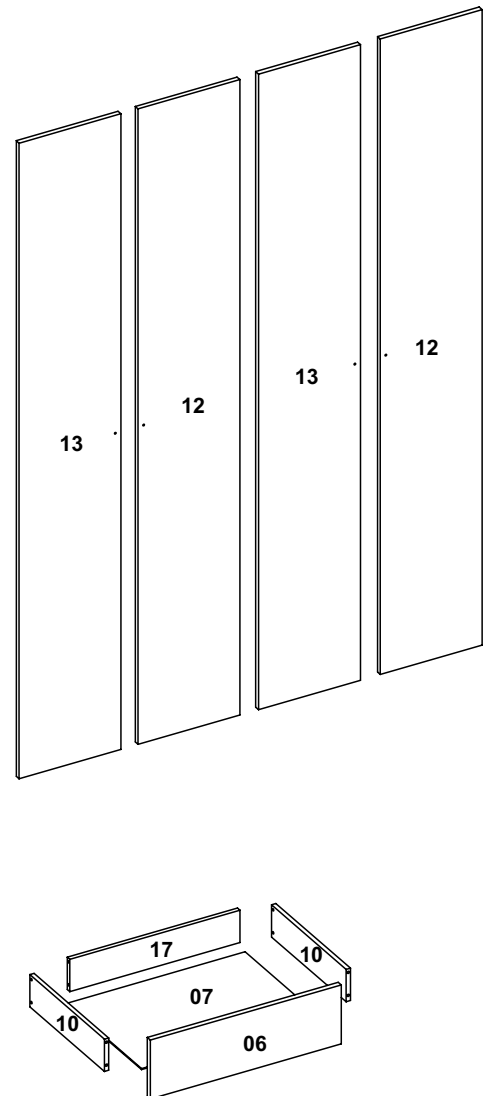
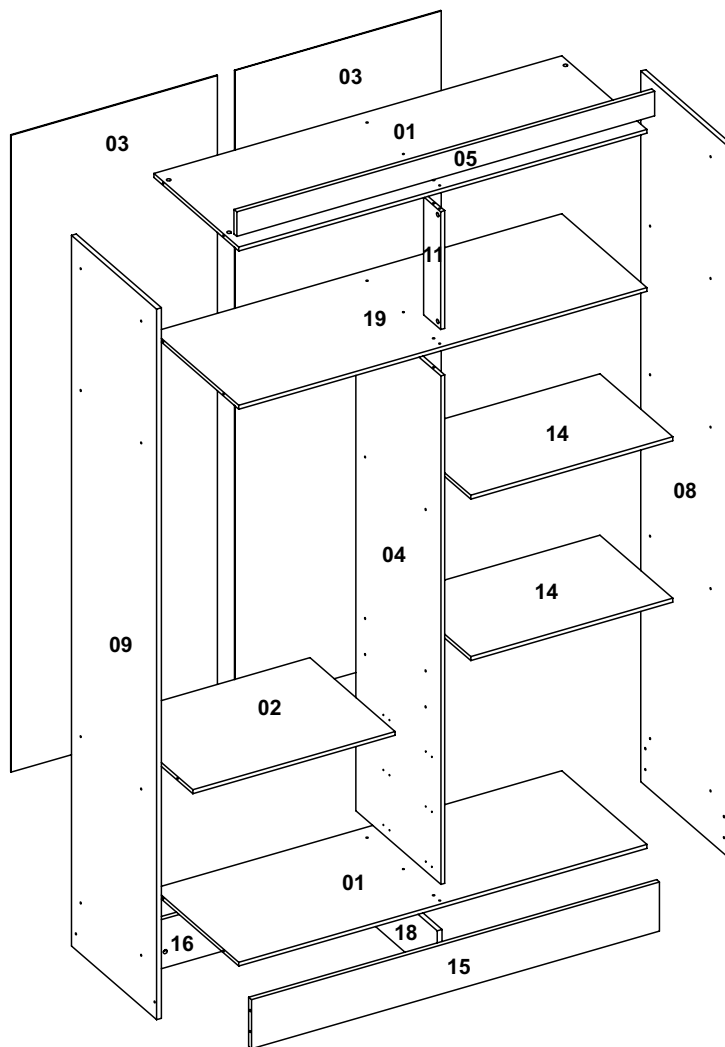

Lista das Ferragens

4,0x40-Cod 3983

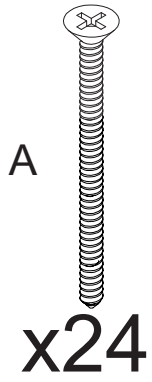

3,5x25-Cod 3870

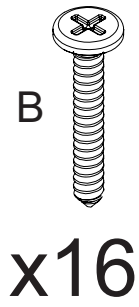

3,5x12-Cod 3385



12x9-Cod 29468

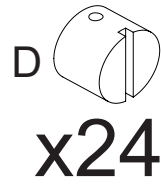

6x30-Cod 3881

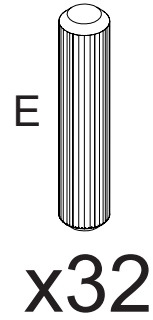

6x50-Cod 8686

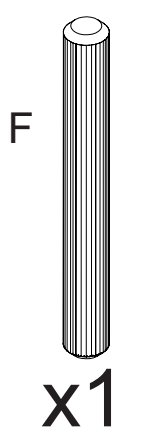

10x10-Cod 3875



Cod 29470

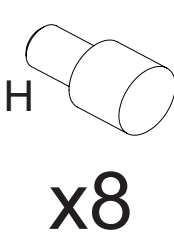

Cod 10865

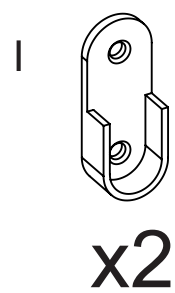

Cod 3877

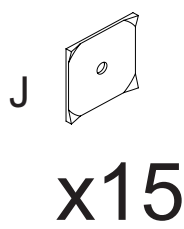

PUX 650MM

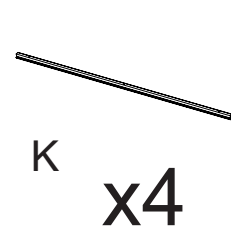

Cod 3882



Cod 3872

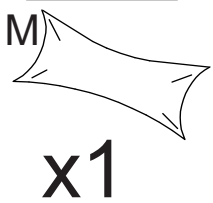

Cod 29299

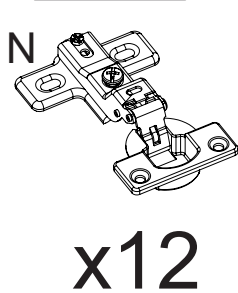

325MM-Cod 27189

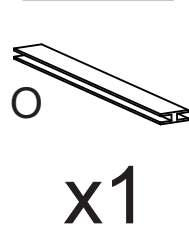

610MM

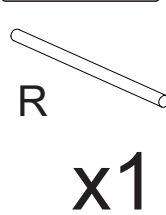

Cantoneira dupla Cod.11409

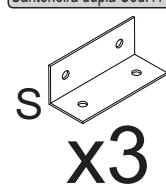

Sapata simples Cod.31331



12x12-Cod 3876

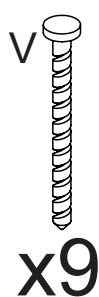

350MM-Cod 16453

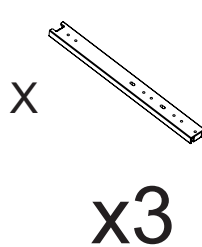

Cod 3387

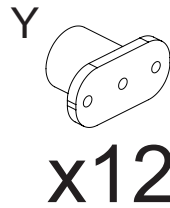

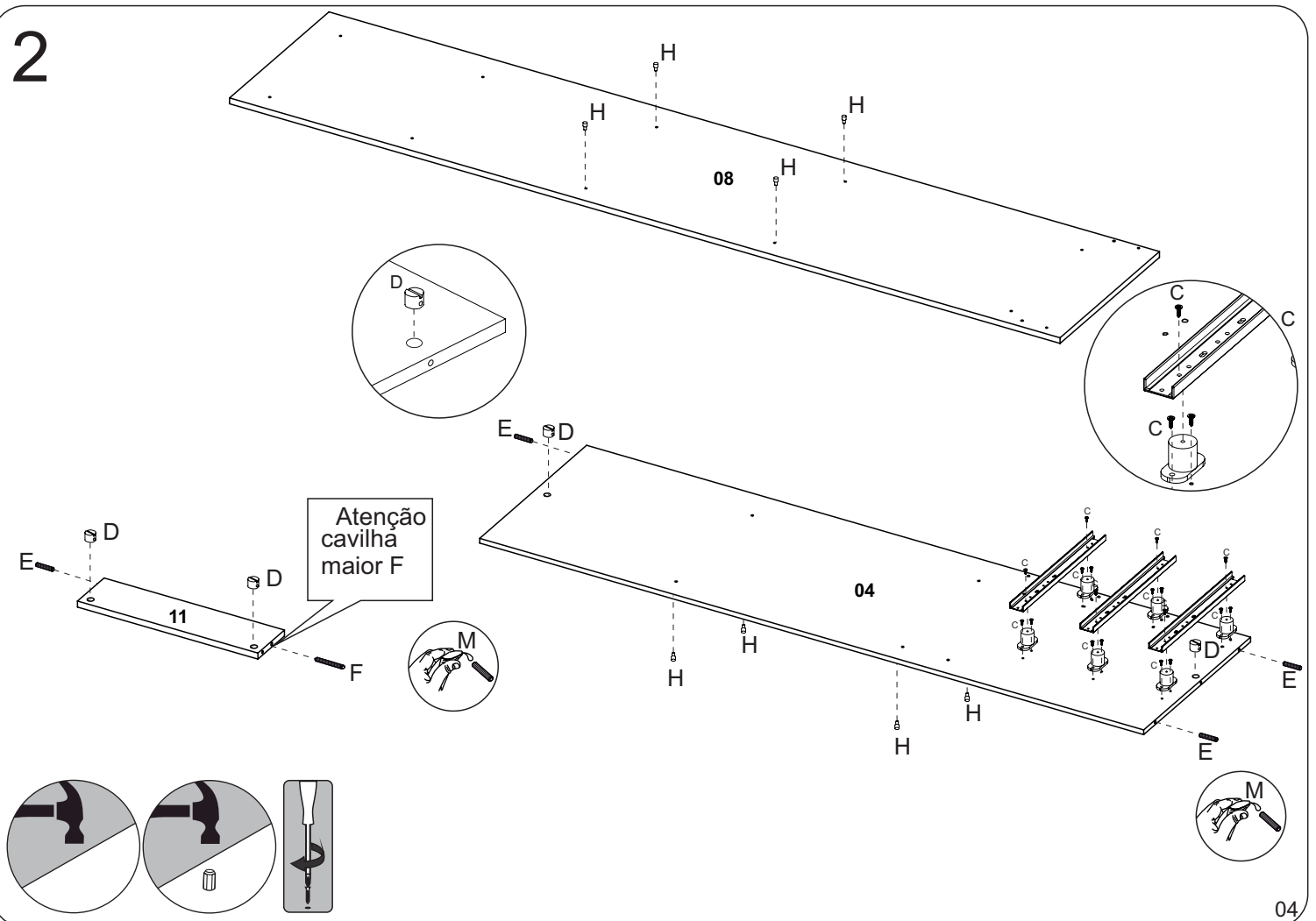
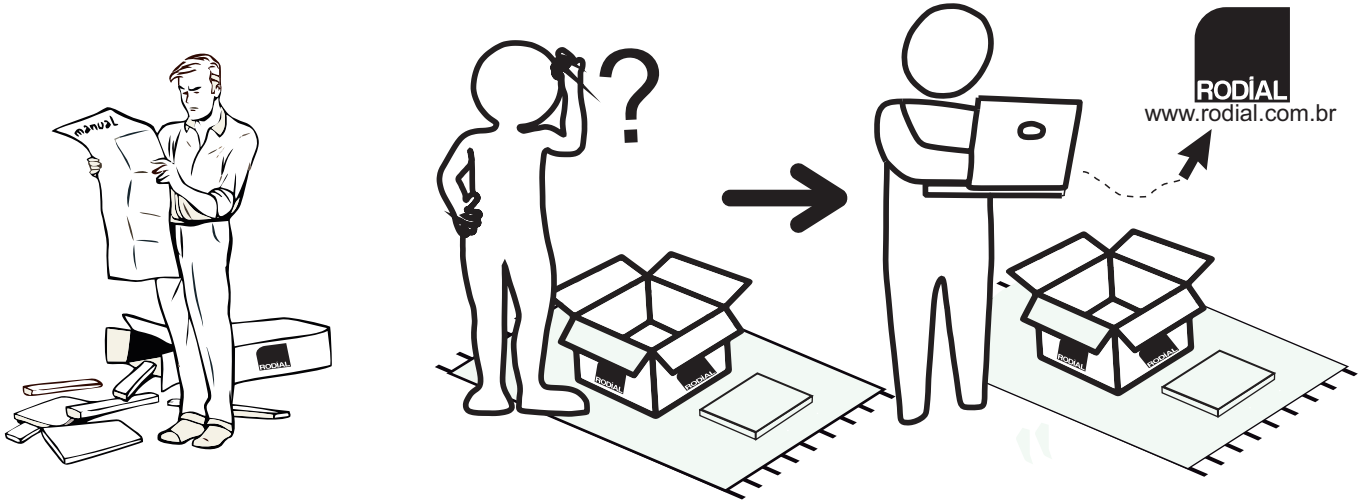
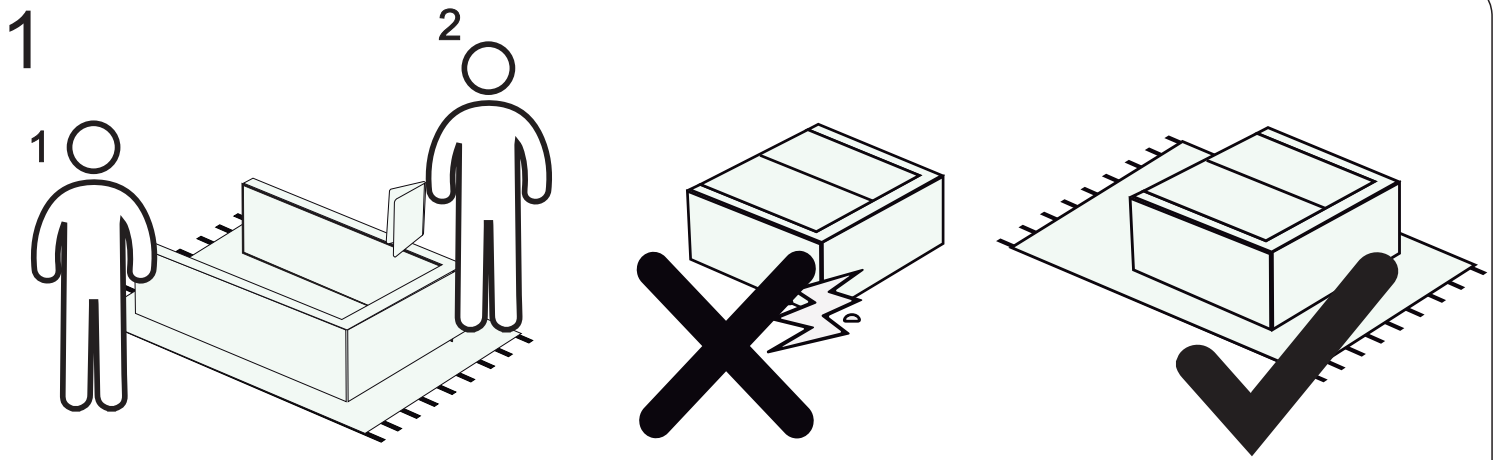

3

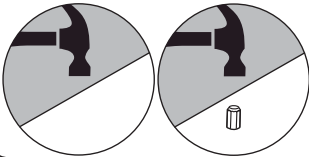
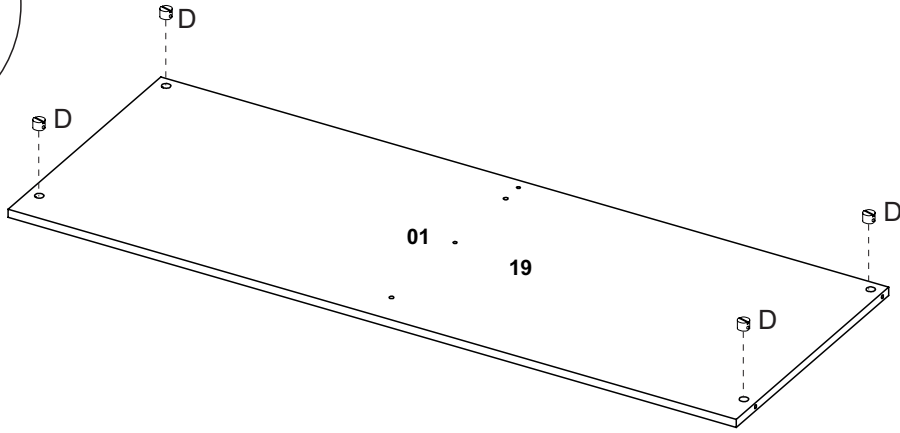
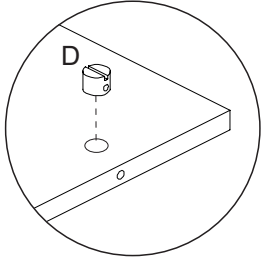
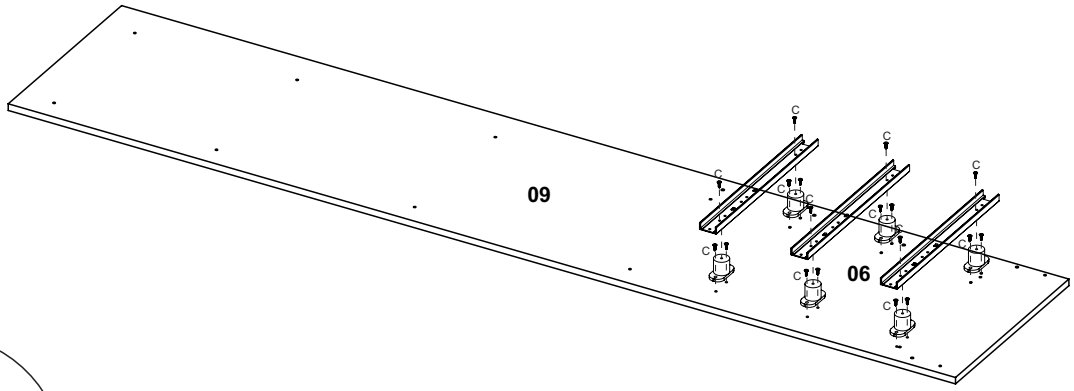

4

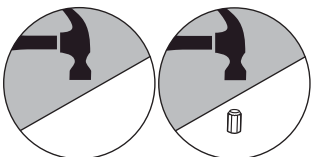
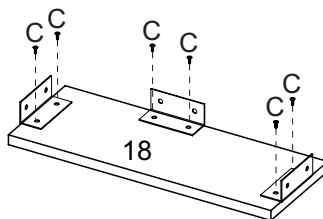
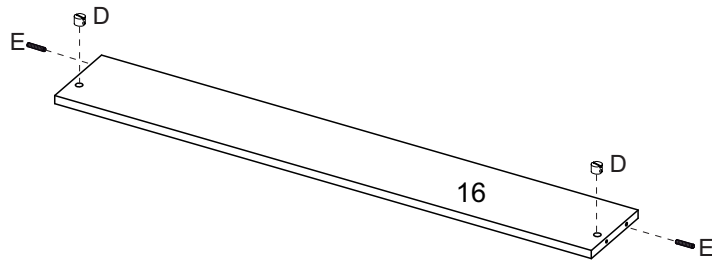
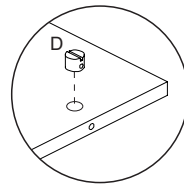
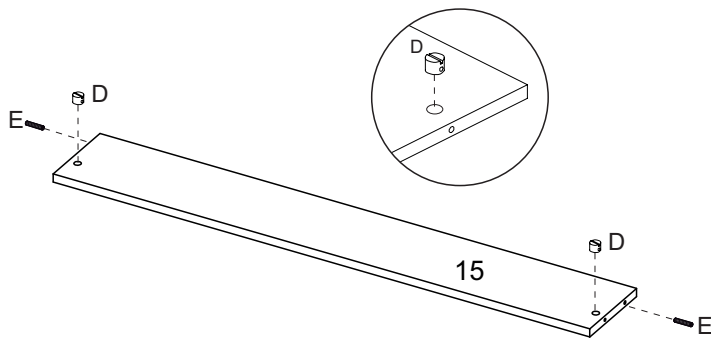

5

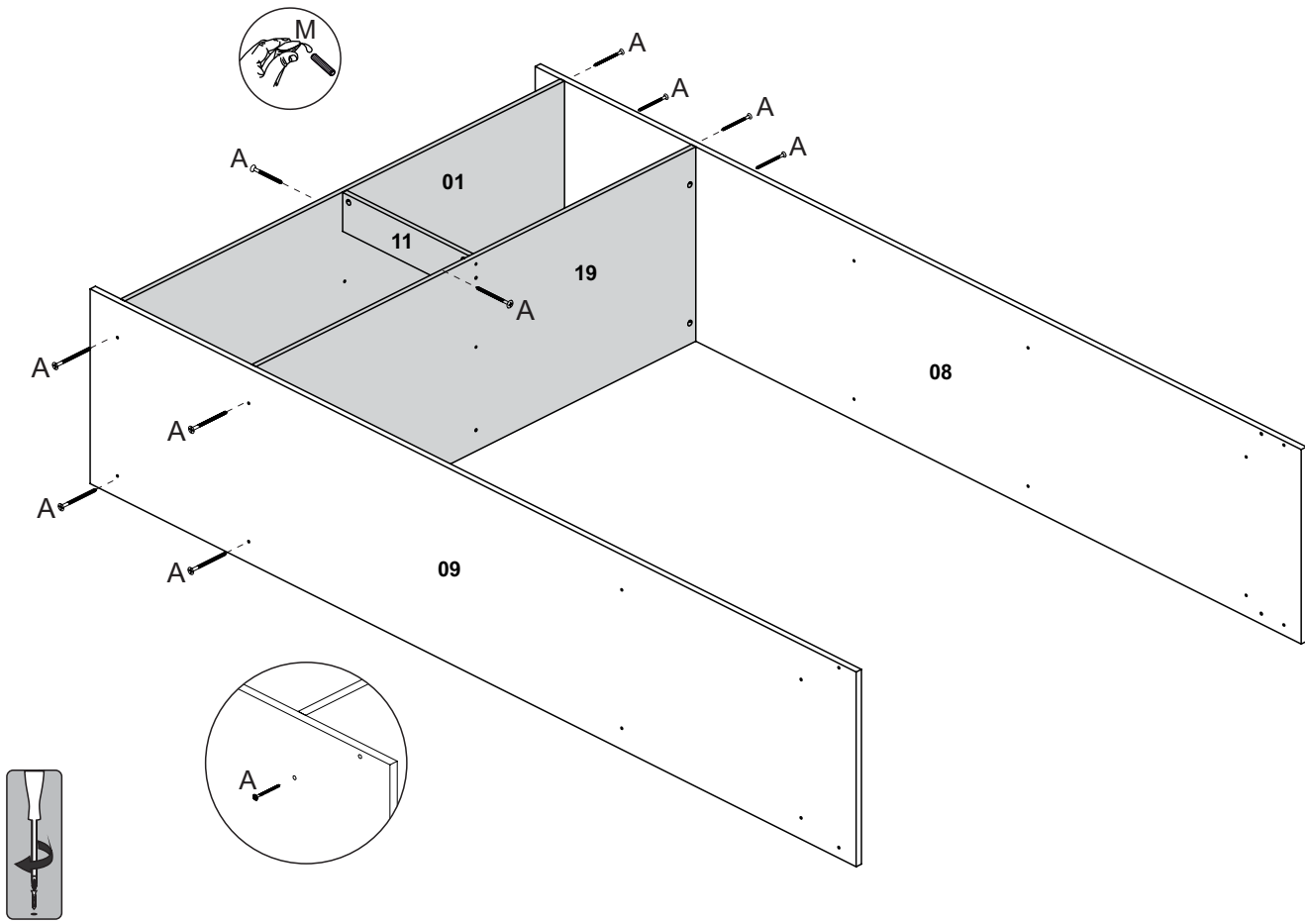

6

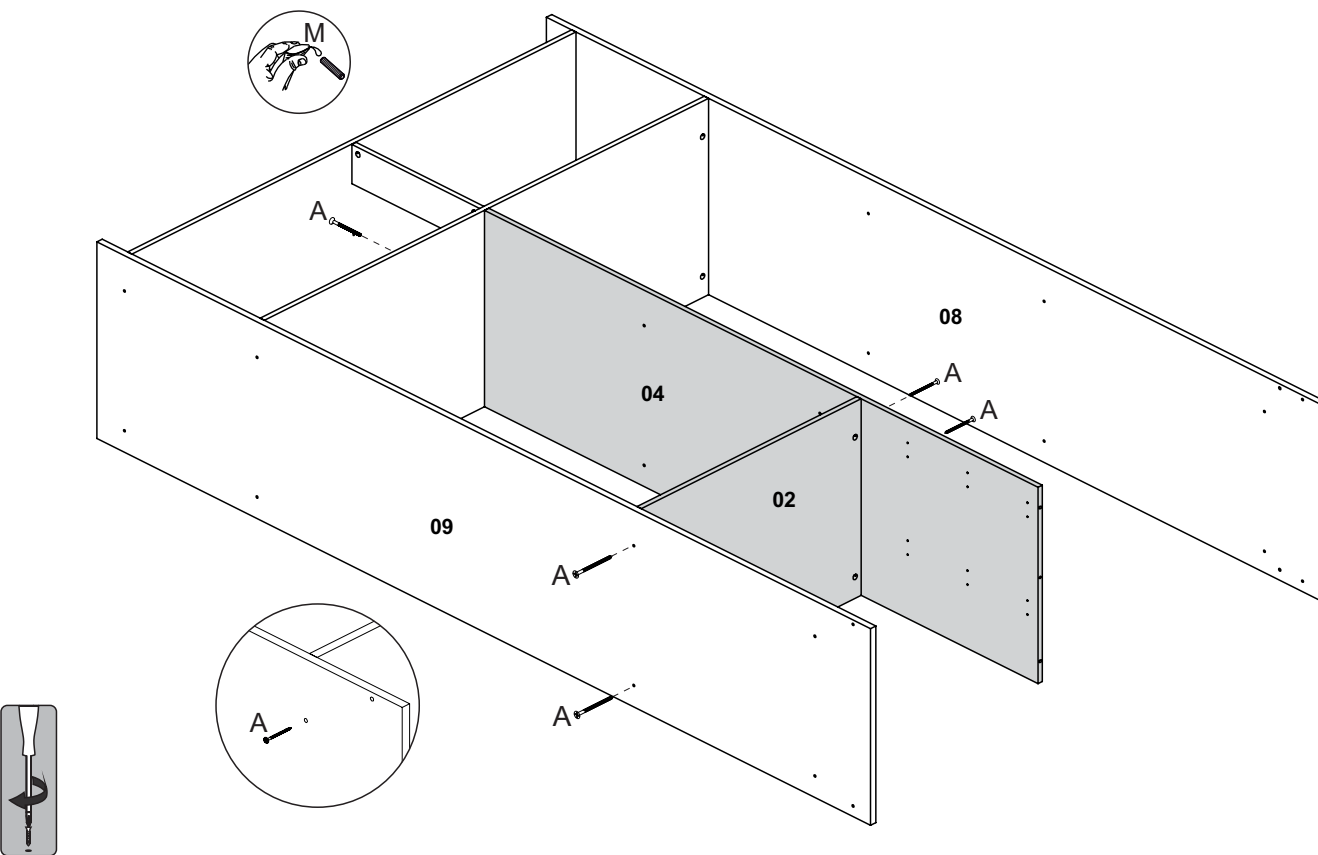

7

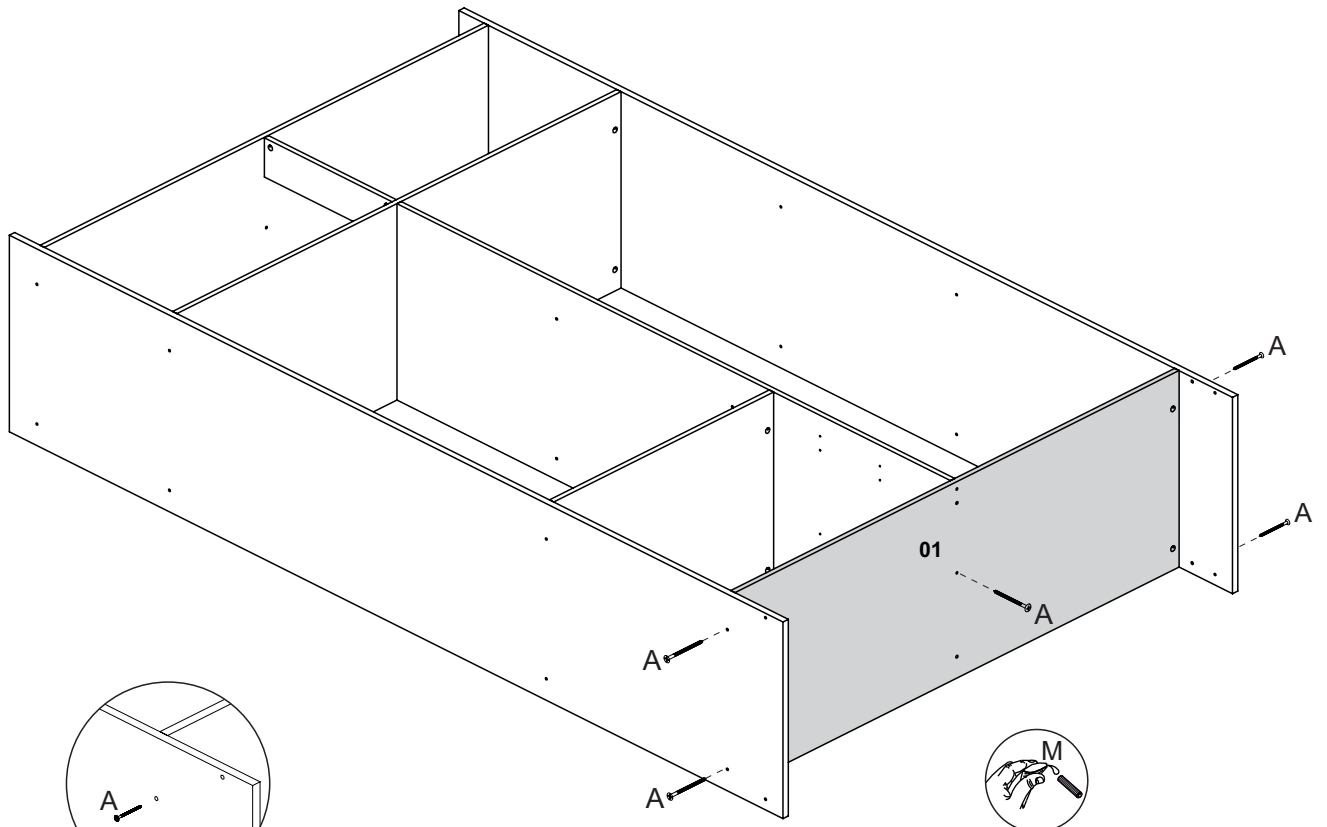

8

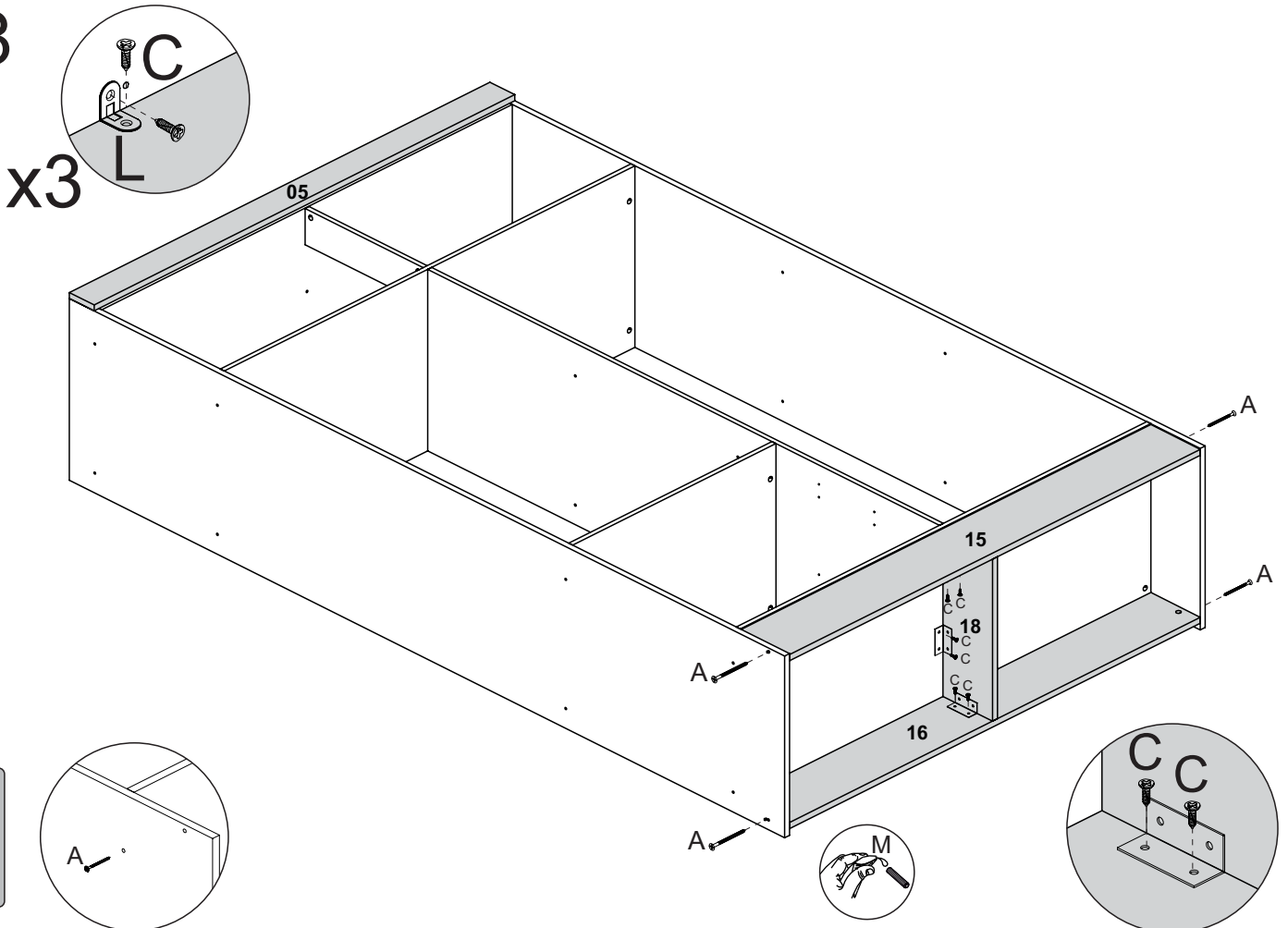

11

N

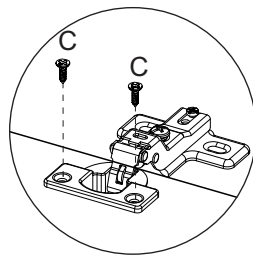
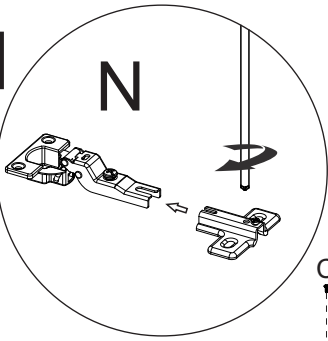

Atenção
*Observar a
 posição correta
 do puxador*

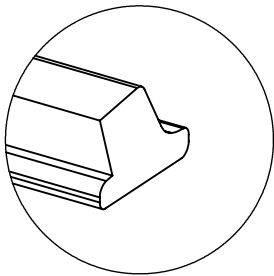
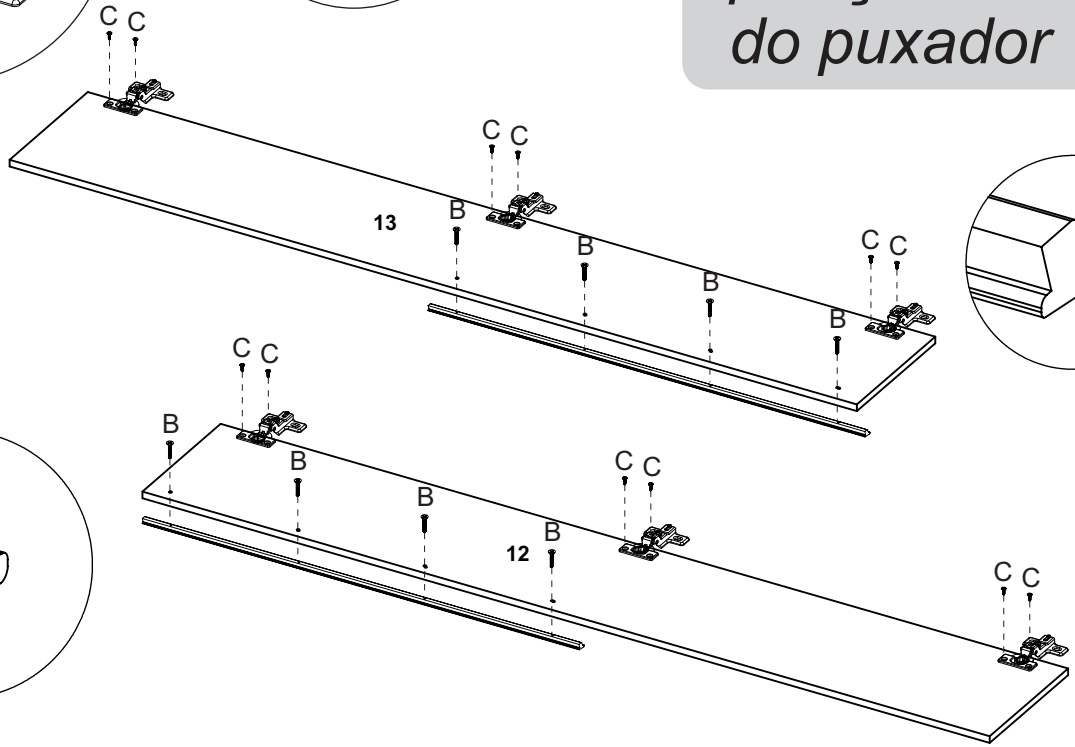

12

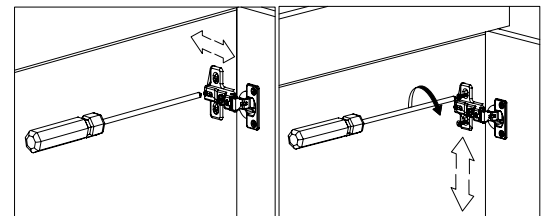
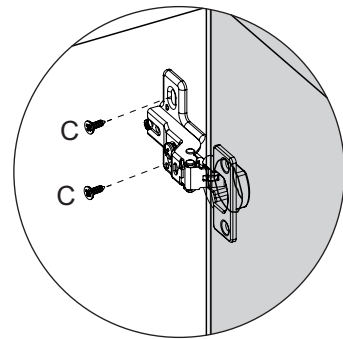
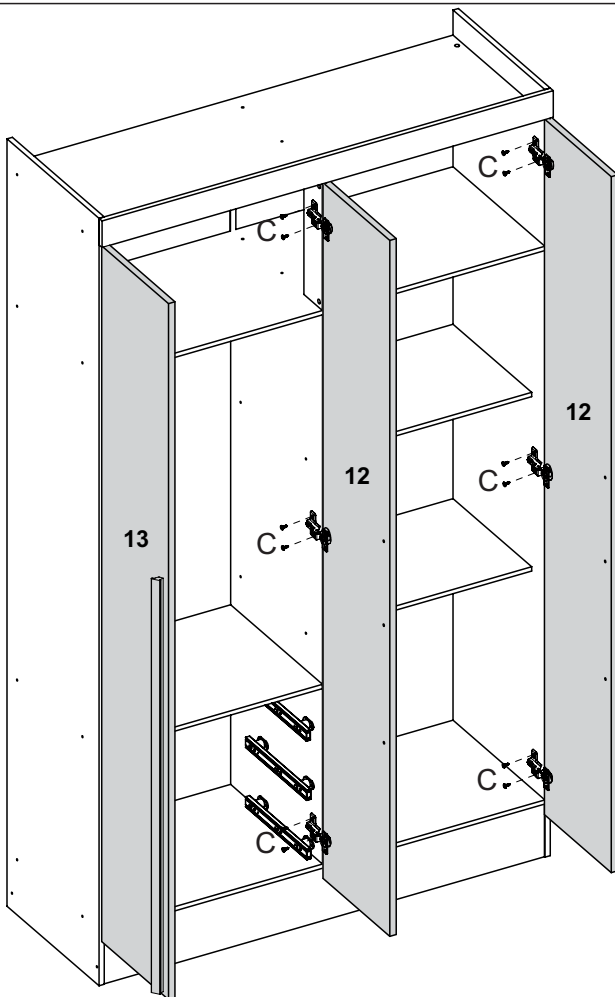

Regulagem da Dobradiça

FIXAÇÃO DO ESPELHO(se adquirido)

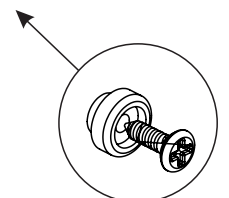
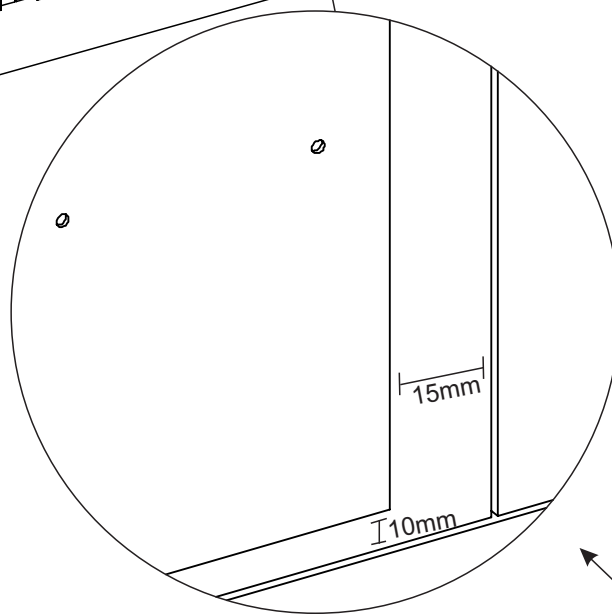
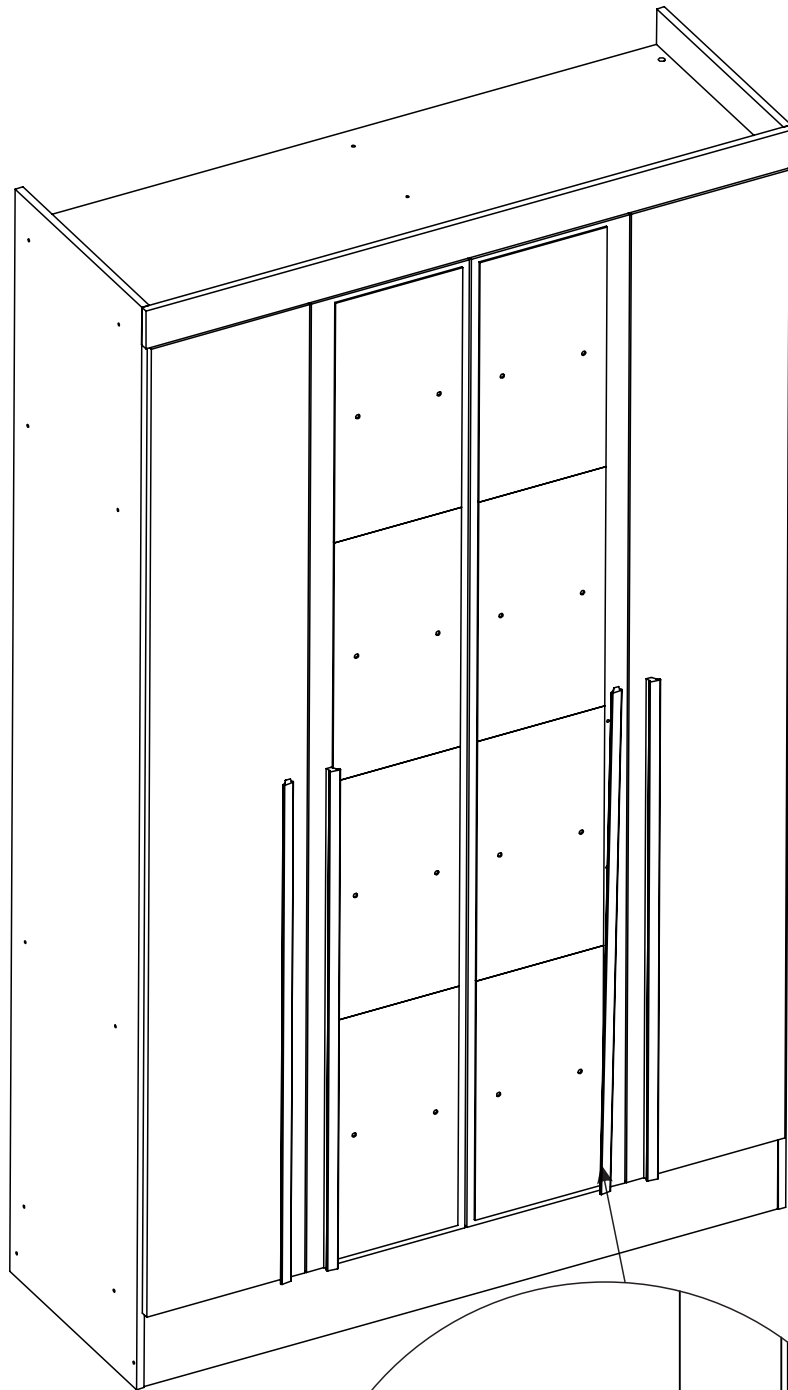

13

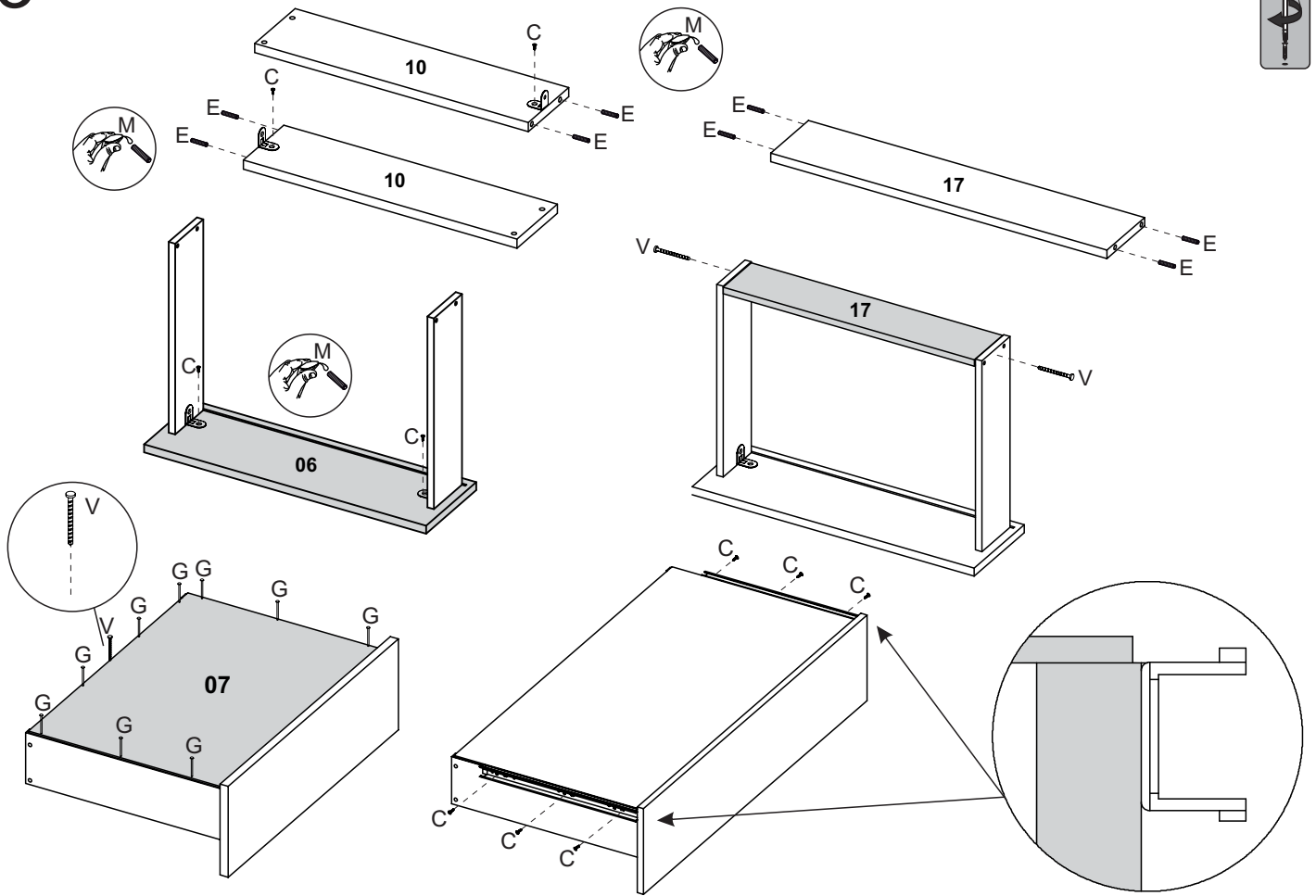

14

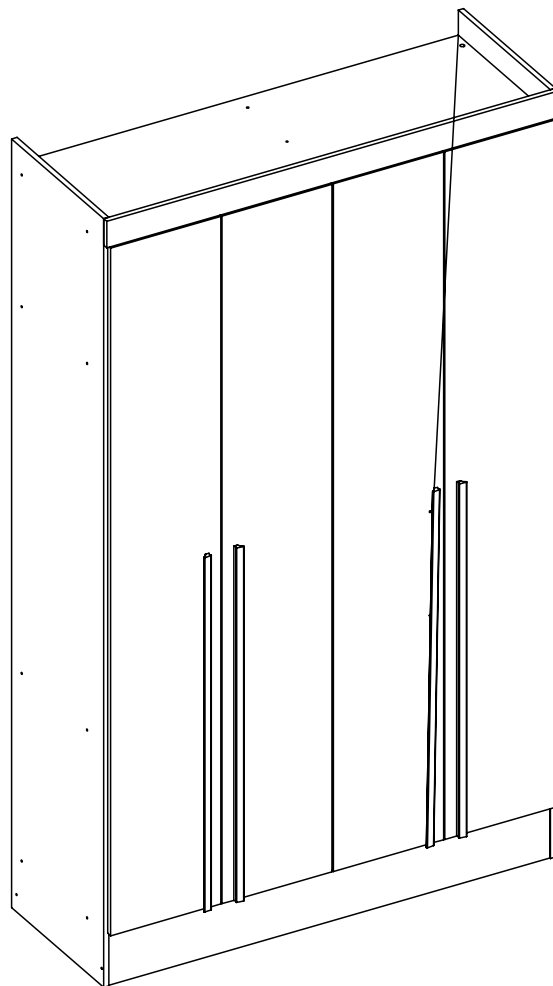

MODULO ESCRIVANINHA ES1500

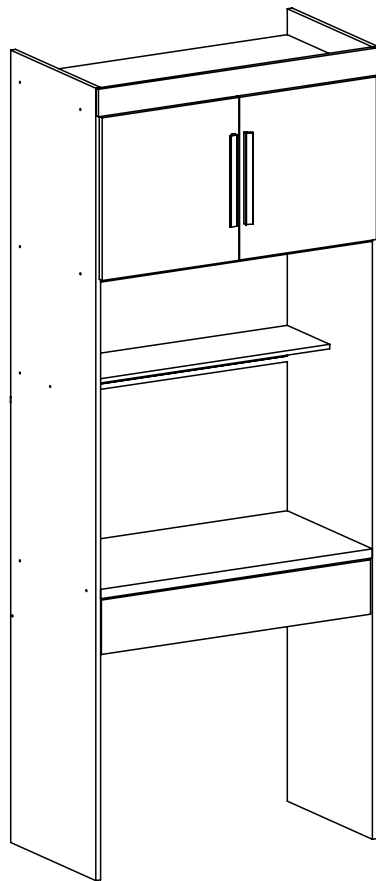

Informações Úteis

É recomendada a prévia leitura de toda a instrução de montagem e conferência das peças e componentes antes de iniciar a montagem do produto.

A montagem do produto deverá ser feita em superfície limpa e plana. Aconselhamos utilizar a embalagem do produto para forrar o chão a fim de não danificar o produto.

Durante a montagem evite batidas e contato com objetos cortantes. Observar as cargas máximas suportado pelo produto.

Limpeza

Retire o pó com uma flanela seca e depois utilize um pano macio umedecido com água.

Não utilizar produtos químicos e abrasivos

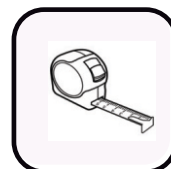
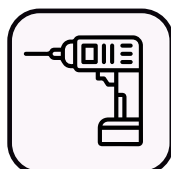

Nº DA PEÇA	DESCRIÇÃO	QTD	CÓD. BRANCO	CÓD. CINAMOMO	CÓD. CINAMOMO OFF WHITE	CÓD. CINAMOMO CAPPUCCINO
1	CHAPÉU 830X450X12	2	30041	30375	30375	30375
2	CHAPÉU 830X225X12	2	35074	34687	34687	34687
3	COSTA 856X431X3	2	35140	34681	34681	34681
4	COSTA 856X454X3	1	35141	34682	34682	34682
5	ENCABEÇAMENTO 860X75X15	1	32989	32768	32768	32768
6	FRENTE GAVETA 822X149X15	1	35098	34683	34683	34683
7	FUNDO DE GAVETA 804X363X3	1	34865	34866	34866	30866
8	LATERAL 2170X450X15 DIR	1	35106	34684	34684	34684
9	LATERAL 2170X450X15 ESQ	1	35107	34685	34685	34685
10	LATERAL DE GAVETA 360X90X12	2	28405	30352	30352	30352
11	PORTA 446X418X15	2	35117	34797	34686	34795
12	TAMPO 830X450X25	1	35130	34688	34688	34688
13	TRASEIRO DE GAVETA 782X90X12	1	30049	30382	30382	30382
14	TRAVESSA 830X150X15	1	35134	34689	34689	34689

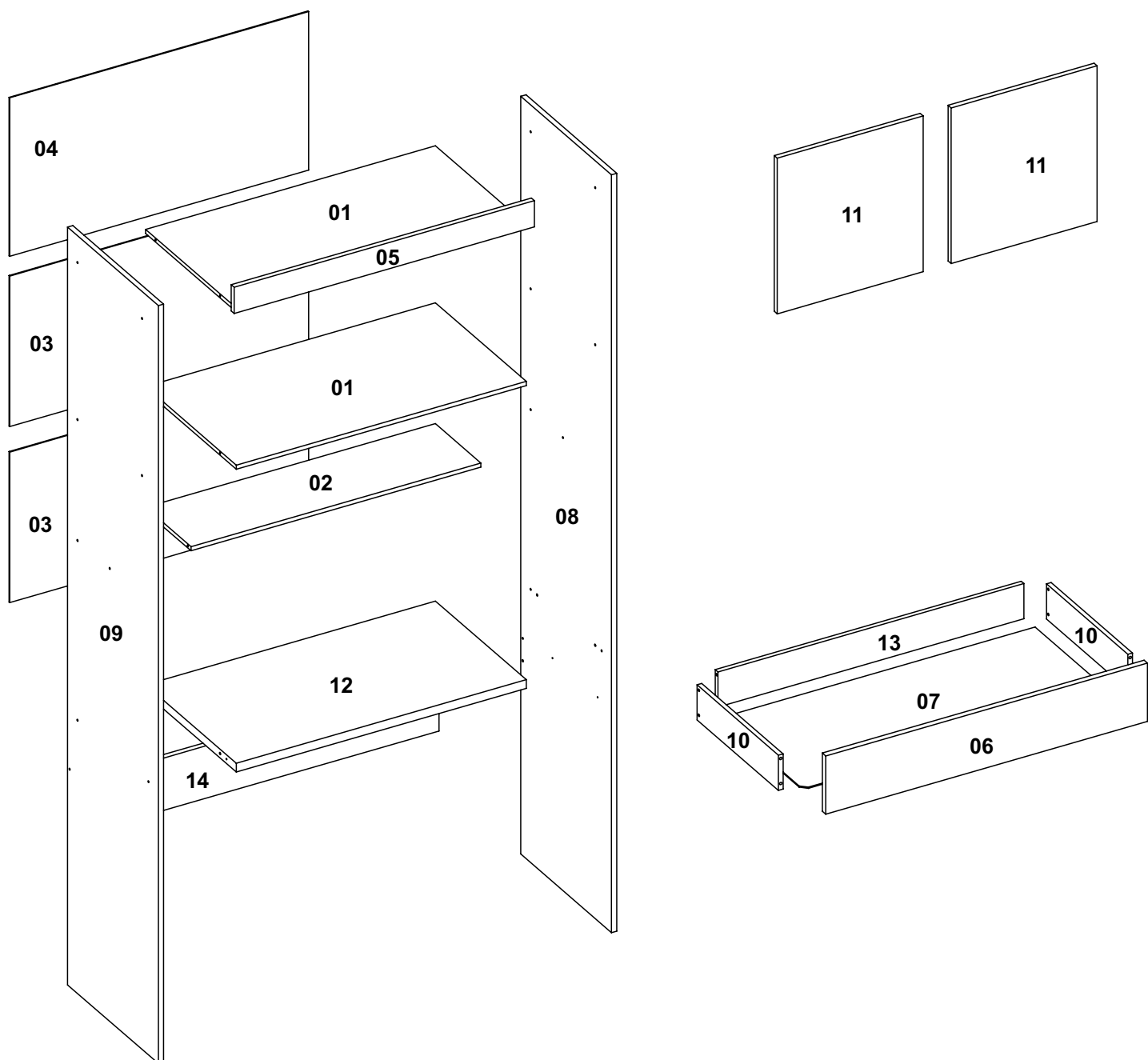

Lista de Ferragens

Parafuso 4,0x40 - Cod.3983

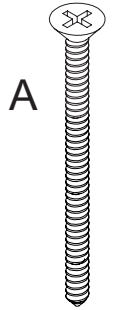

A

x18

Parafuso 3,5x12 Cód.3385



B

x40

Porca plástica Cód.3991



C

x14

Cavilha 6x30 Cód.3881



D

x14

Prego 10x10 Cód.33412



E

x90

12x12-Cod 3876



F

x15

856mm

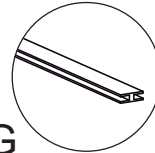

G

x1

Sapata simples Cód.31330

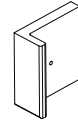

H

x4

Cod 3882

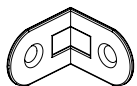

I

x5

3,5x25-cod 7182

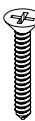

J

x6

192MM

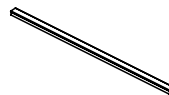

K

x2

3,5x25-Cod 3870

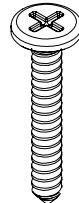

L

x4

Cod 3384

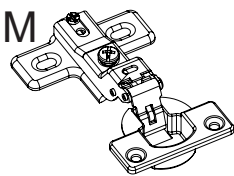

M

x4

Cod 3872

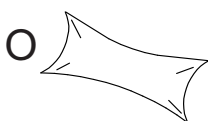

O

x1

Cod 3877

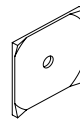

P

x10

300MM-Cod 29265

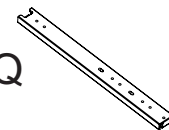

Q

x1

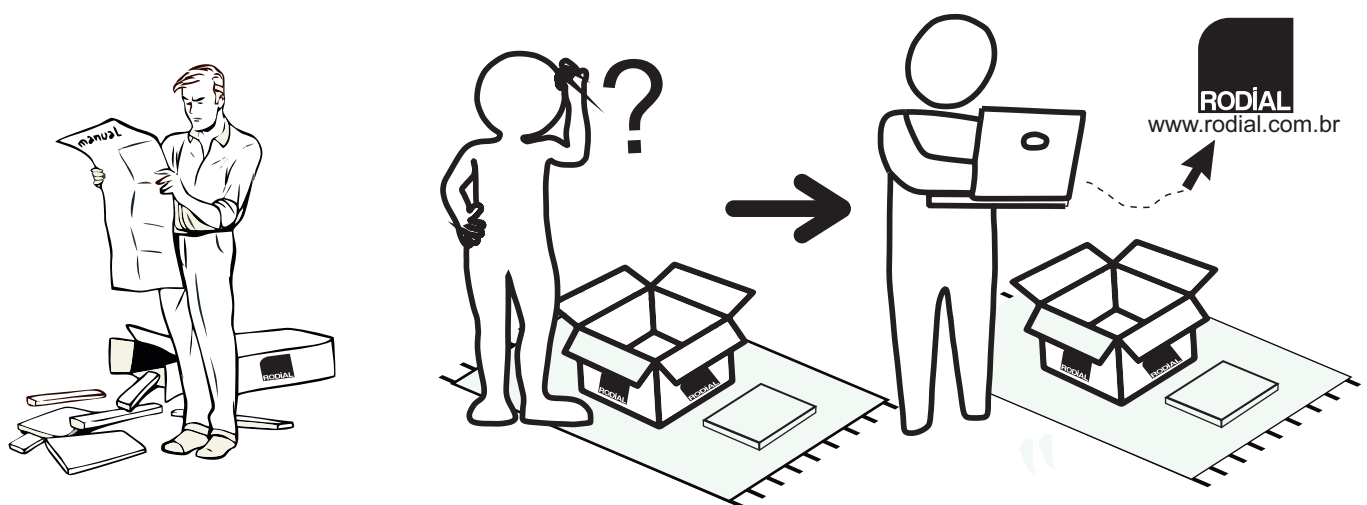
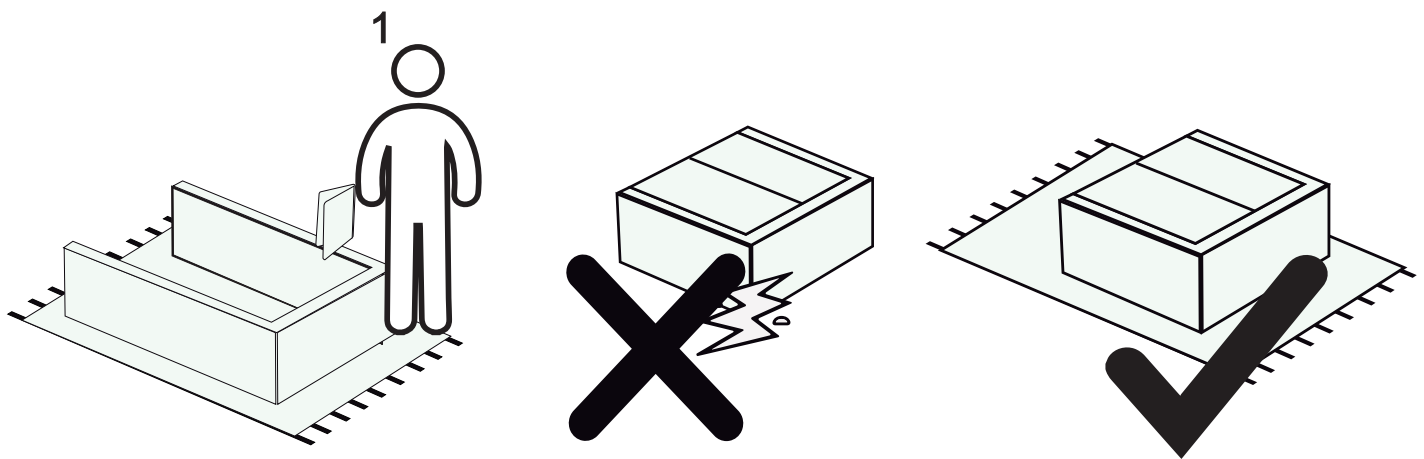

Pressione a trava para
desmontar a corredeira
para ser usada na montagem
da gaveta.

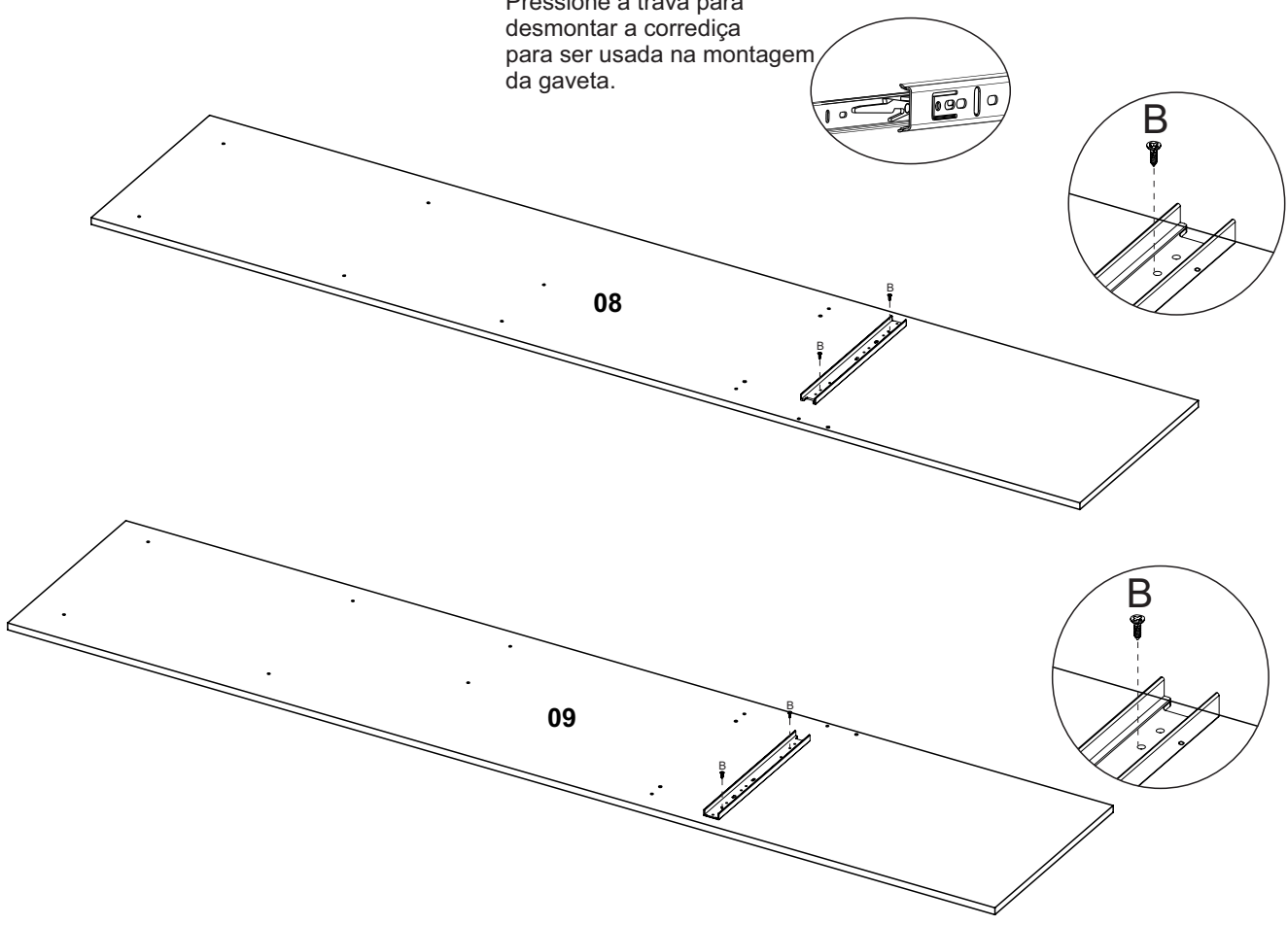

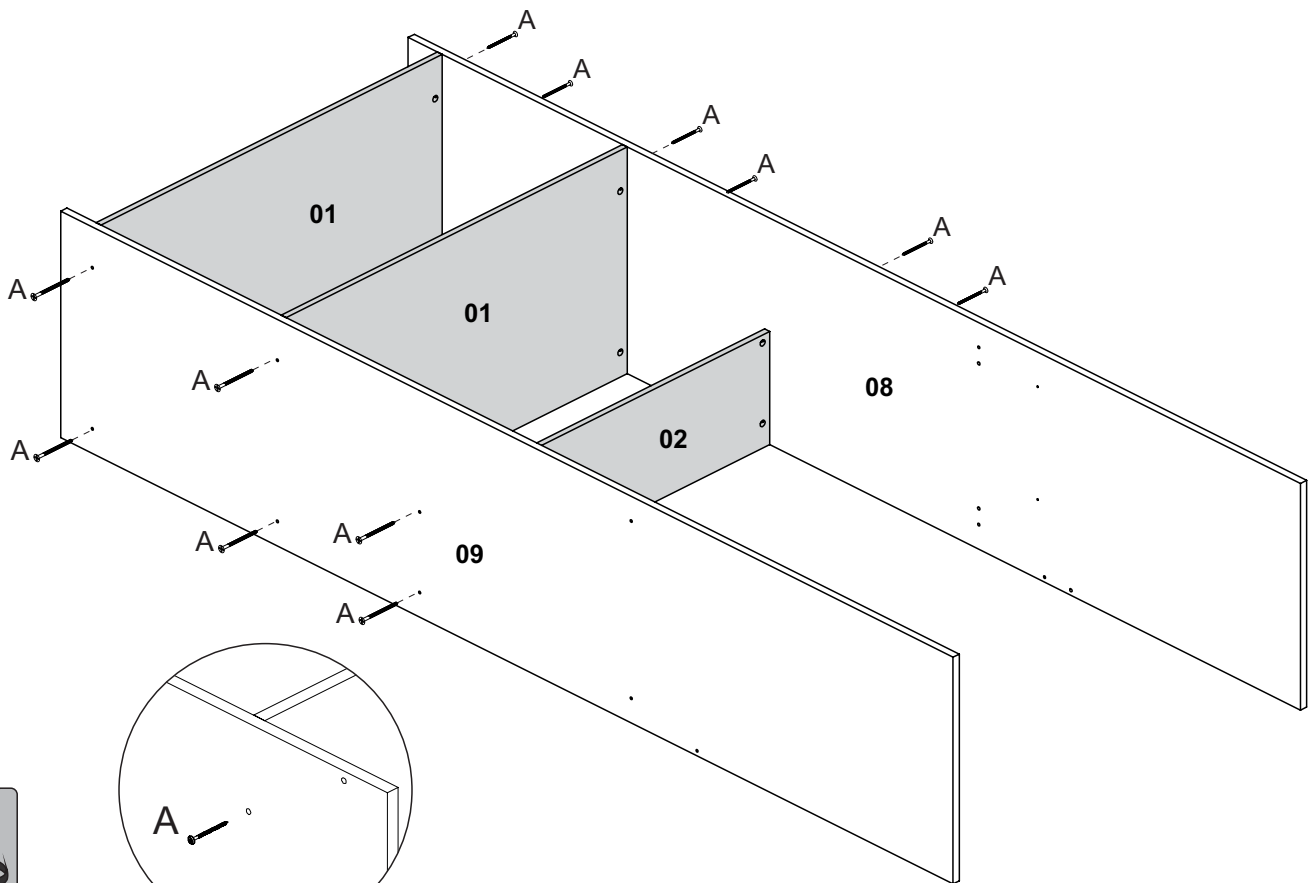
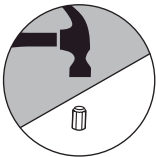
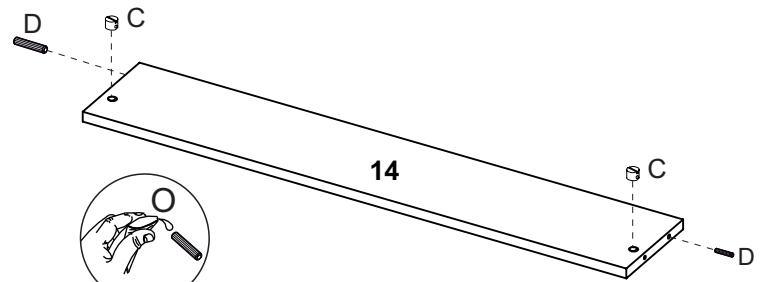
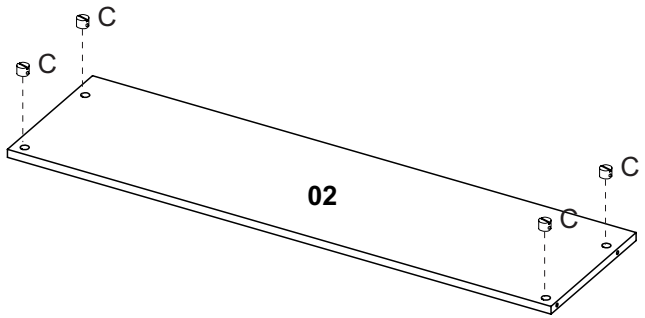
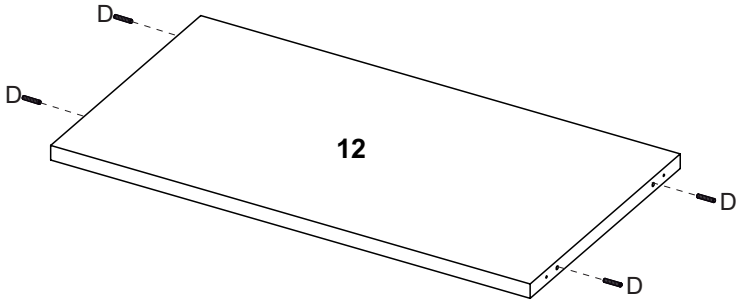
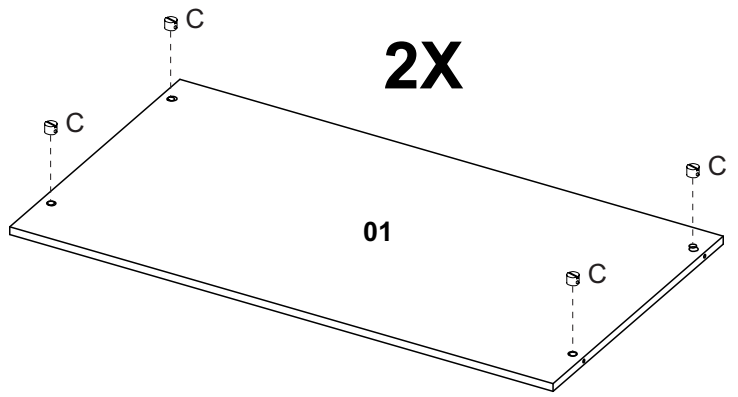
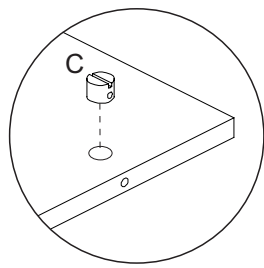

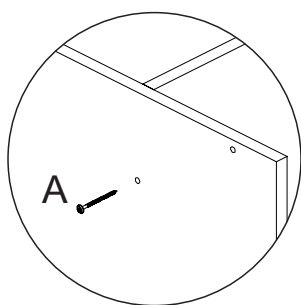
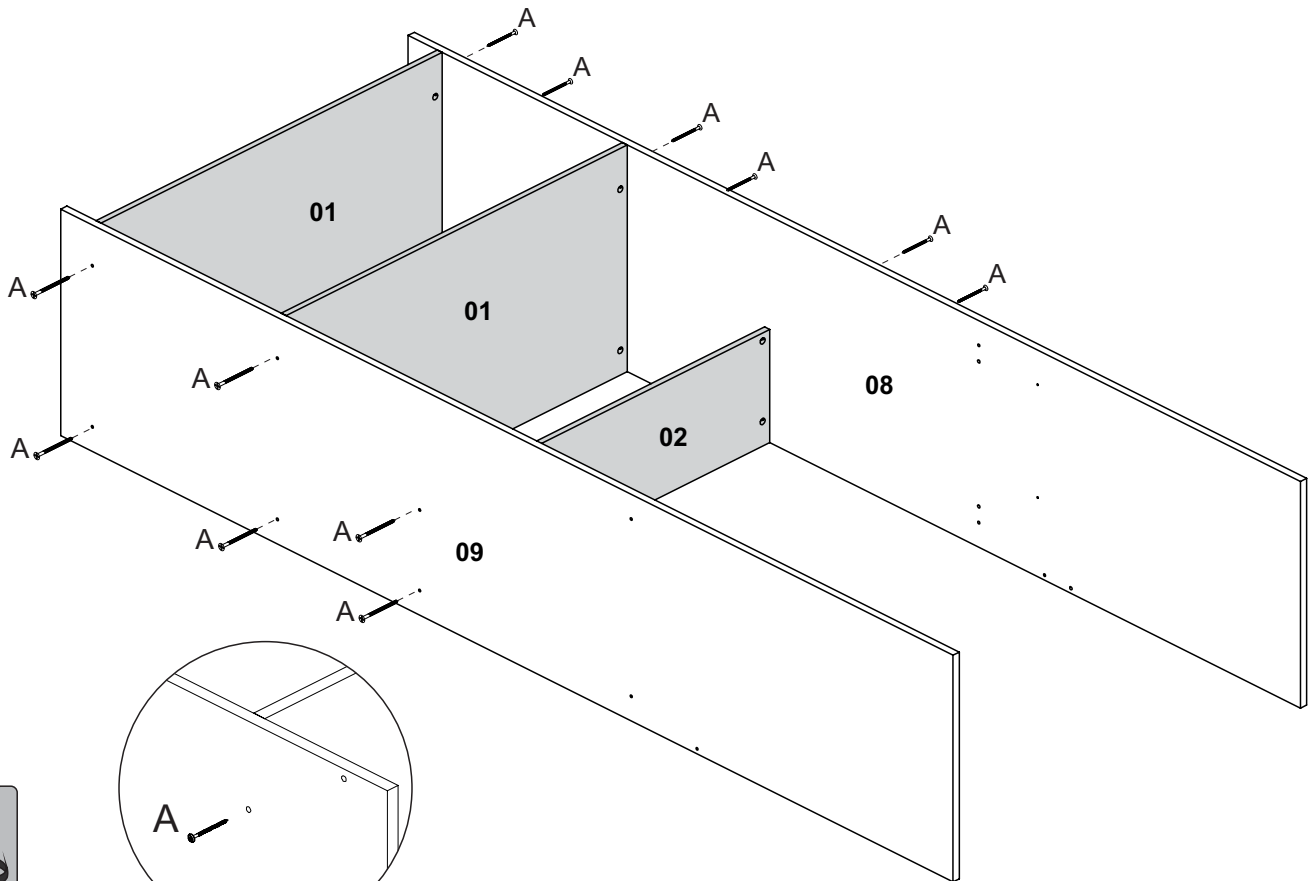
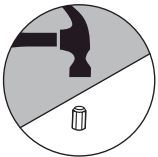
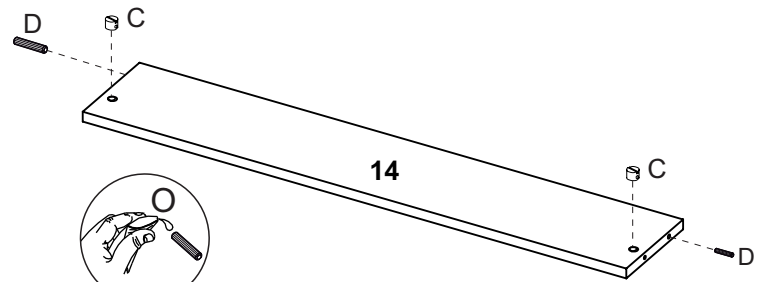
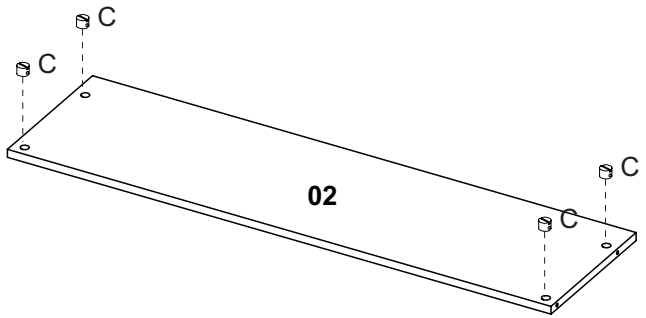
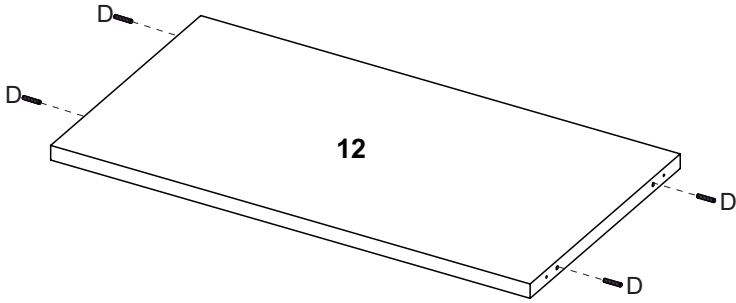
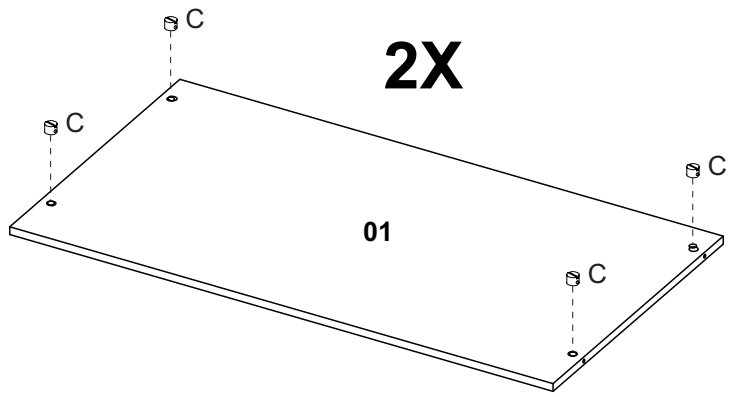
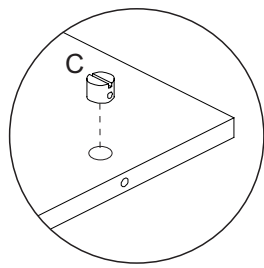

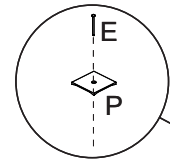
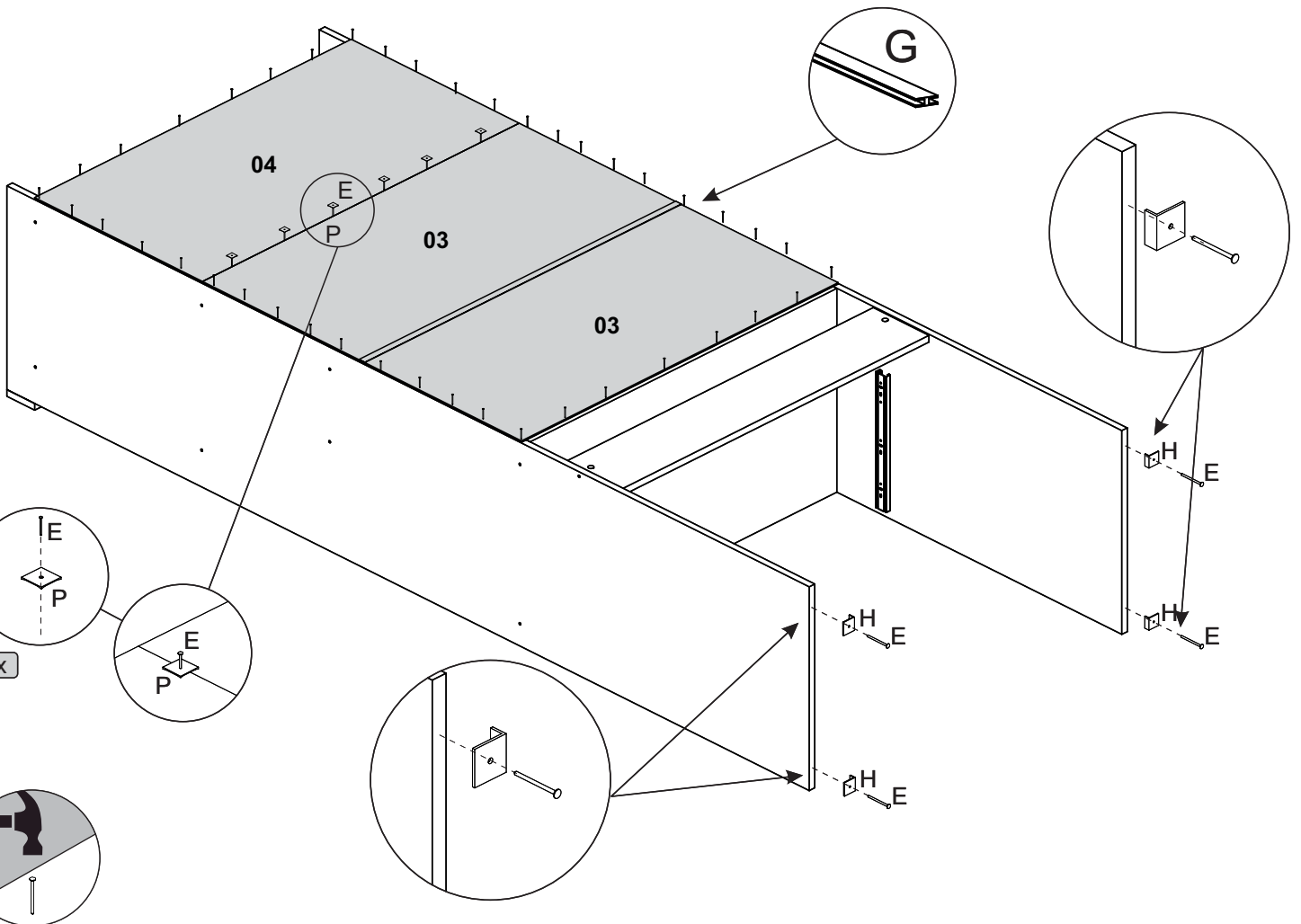
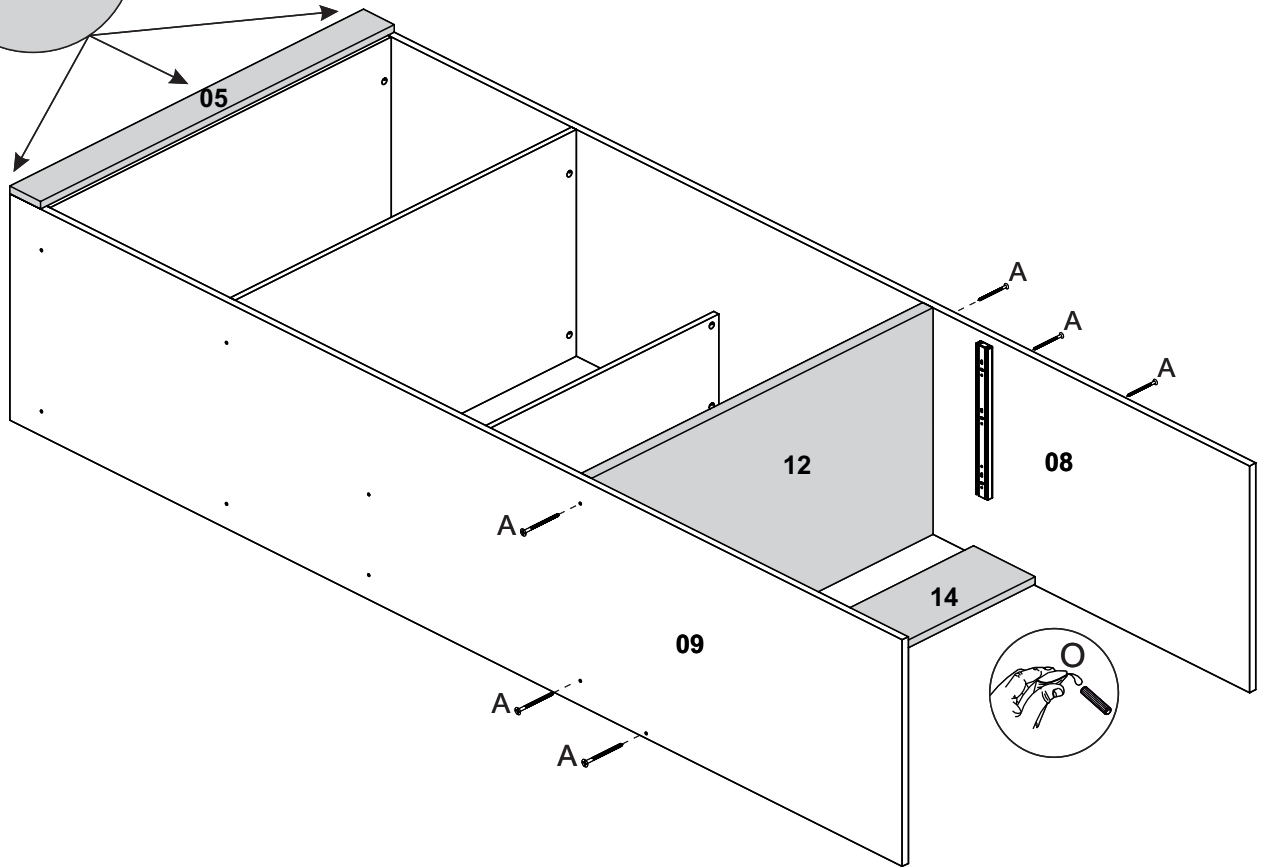
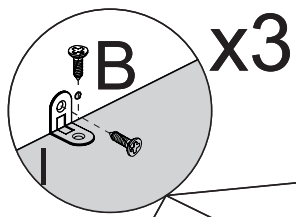

10x

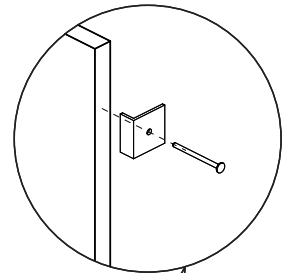
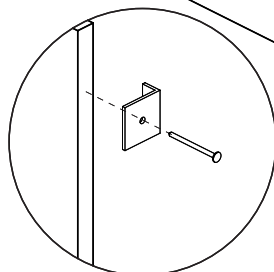
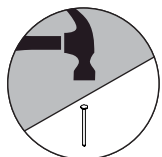
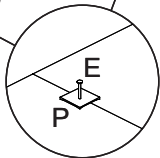

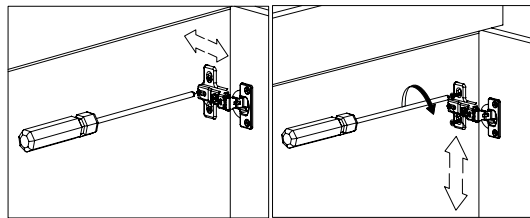
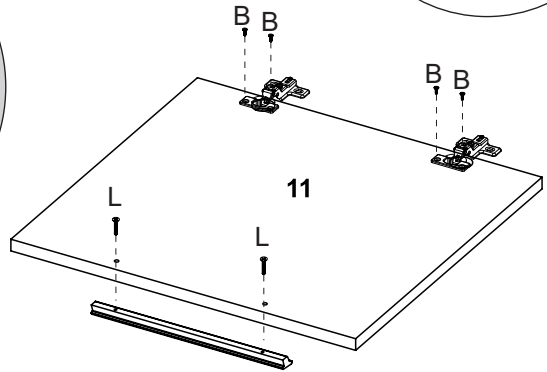
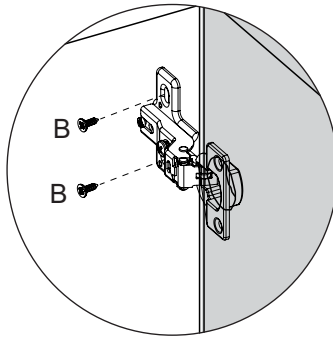
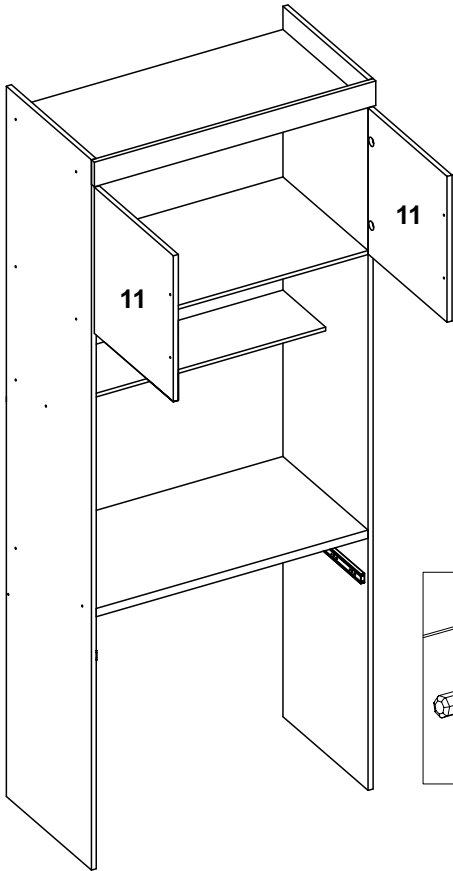
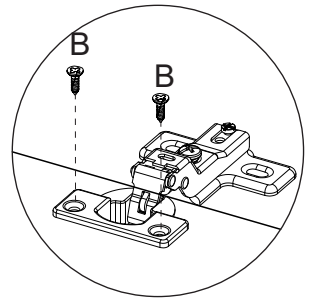
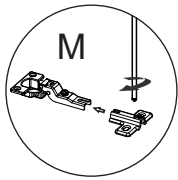

Regulagem da Dobradiça

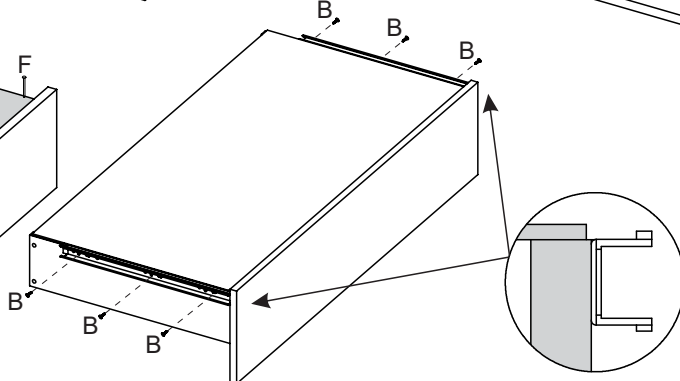
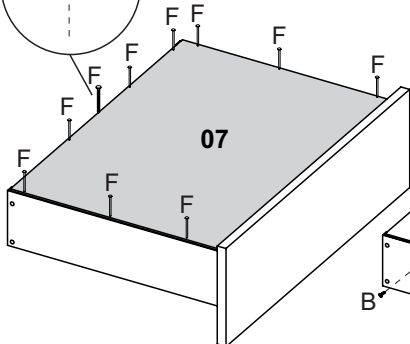
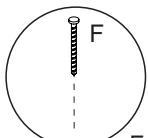
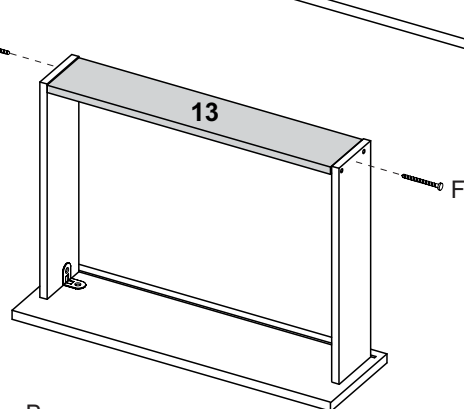
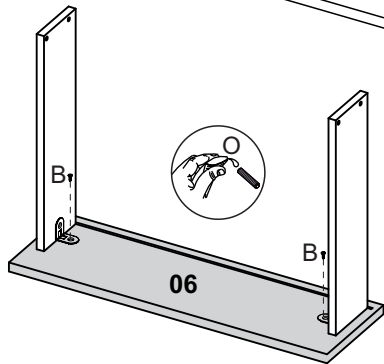
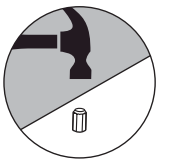
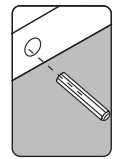
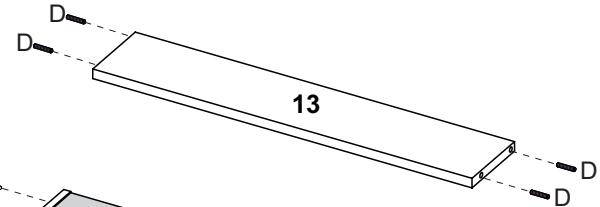
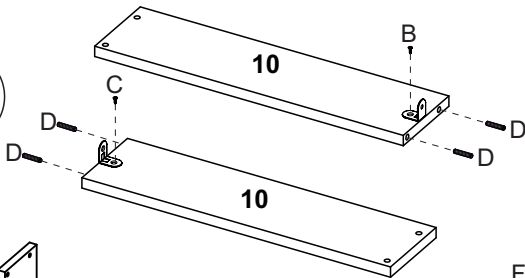

União com Outros Modulos(Opcional)

