

madesa

1018 / 1028 / 1118

1018

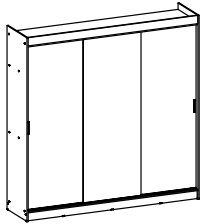

1018-1E

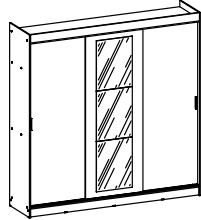

1018-2E

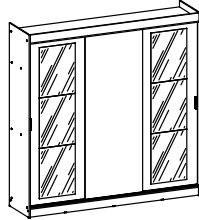

1018-3E

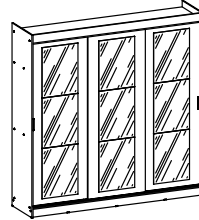

1118-1E

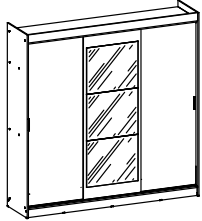

1118-2E

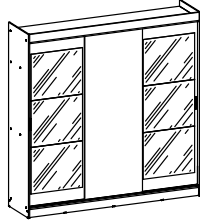

1118-3E

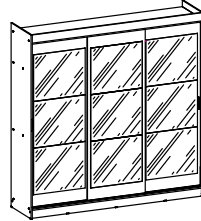

1028

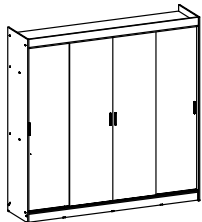

1028-2E

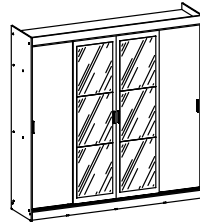

1028-4E

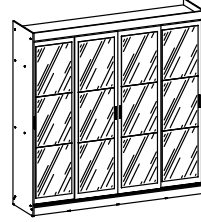

Comprimento / Longitud / Width: 215cm - Altura / Altura / Height: 218cm - Profundidade / Profundidad / Depth: 54cm

O móvel deve ser montado por duas pessoas, em uma superfície limpa e plana.

El mueble debe ser ensamblado por dos personas sobre una superficie limpia y plana.

The furniture should be assembled by two people on a clean, flat surface.

Ferramentas necessárias / Herramientas necesarias / Required tools:

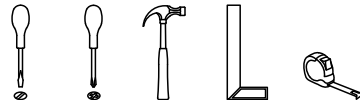

1018 / 1118

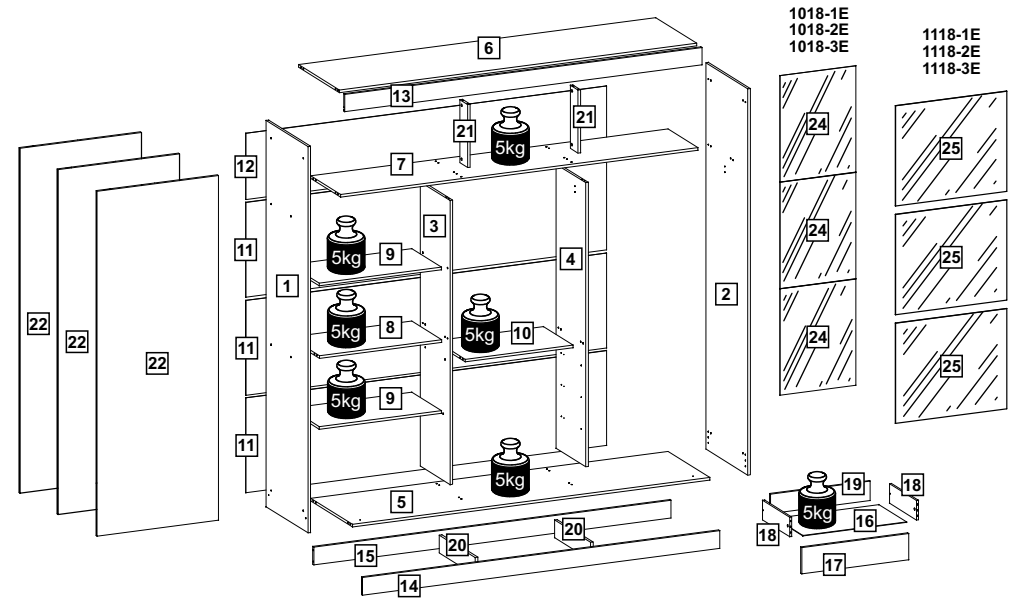

1028

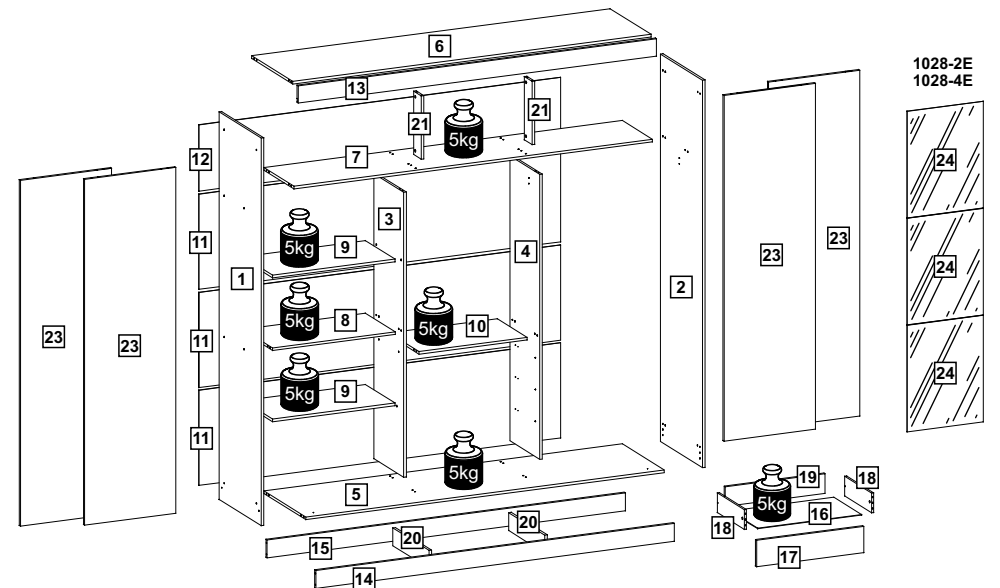

TAMANHO REAL
TAMAÑO VERDADERO
REAL SIZE

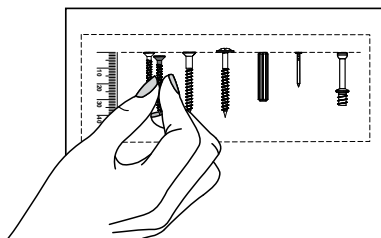

MM

A	B	C	D	E	F	G	H	I	J
61x	40x	40x	8x	6x	16x	32x	52x	185x	10x

X	Y	Z
8x	8x	1x

AA	AB	AC
1x	1x	1x

AD	AE
4x	1x

AF
3x

A24

K	L	M	N	O	P	Q	R
6x	4x	16x	8x	3x	21x	28x	10x

S	T	U	V	W
2x	4x	6x	4x	8x

2120mm

PEÇAS / PARTES / PARTS

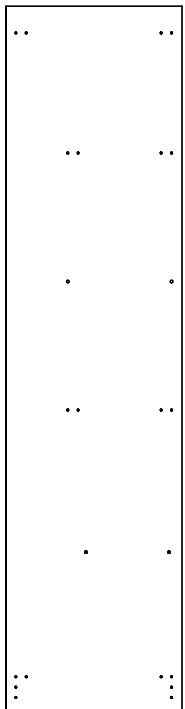

1 (15 x 542 x 2175 mm)

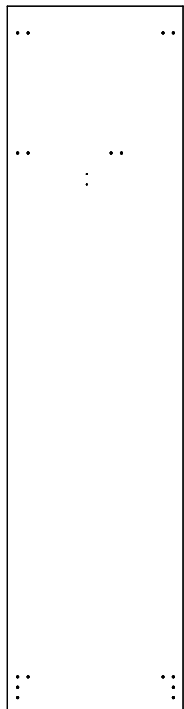

2 (15 x 542 x 2175 mm)



3 (15 x 385 x 1600 mm)

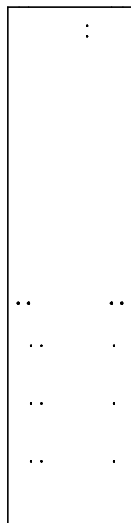

4 (15 x 385 x 1600 mm)

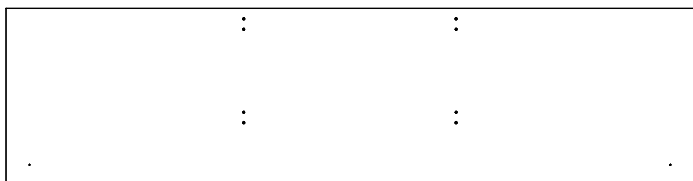

5 (15 x 540 x 2120 mm)



8 (15 x 384 x 725 mm)

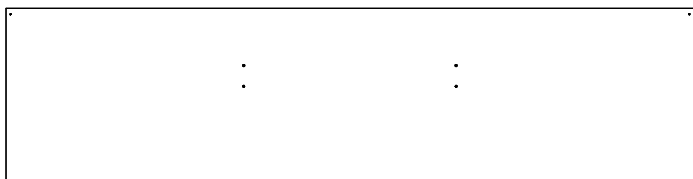

6 (15 x 529 x 2120 mm)



9 (15 x 383 x 725 mm) - 2x



7 (15 x 387 x 2120 mm)



10 (15 x 384 x 640 mm)



11 (3 x 534 x 2140 mm) - 3x

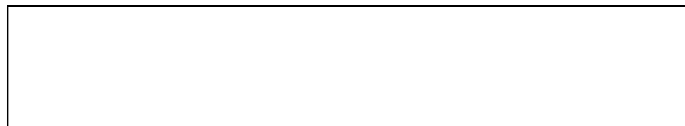

12 (3 x 372 x 2140 mm)

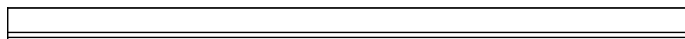

13 (15 x 100 x 2120 mm)

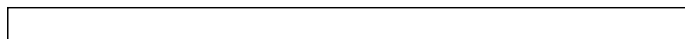

14 (15 x 100 x 2120 mm)

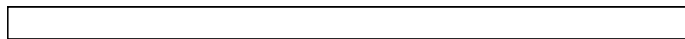

15 (15 x 100 x 2120 mm)



16 (3 x 614 x 357 mm) - 3x

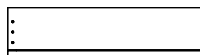

17 (15 x 146 x 633mm) - 3x

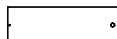

18 (12 x 110 x 350 mm) - 6x

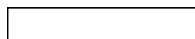

19 (12 x 110 x 591 mm) - 3x

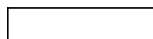

20 (15 x 100 x 465 mm) - 2x

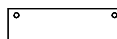

21 (15 x 100 x 355 mm) - 2x

▲ 1018 / 1118

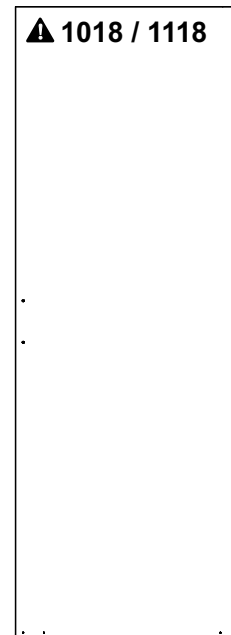

22 (15 x 720 x 1941 mm)

1018: 3x
1118: 3x
1028: 0x

▲ 1028

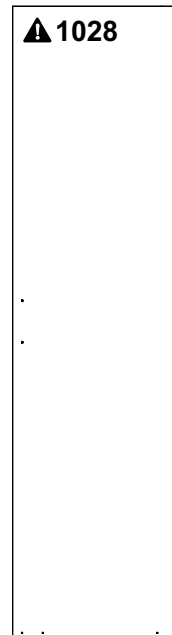

23 (15 x 539 x 1941 mm)

1018: 0x
1118: 0x
1028: 4x

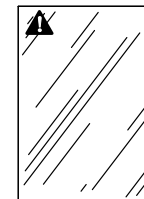

24 (3 x 595 x 450 mm)

1018: 0x
1018-1E: 3x
1018-2E: 6x
1018-3E: 9x

1118-1E: 0x
1118-2E: 0x
1118-3E: 0x

1028: 0x
1028-2E: 6x
1028-4E: 12x

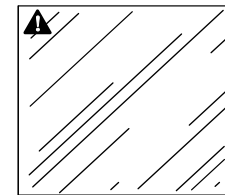

25 (3 x 550 x 644 mm)

1018: 0x
1018-1E: 0x
1018-2E: 0x
1018-3E: 0x

1118-1E: 3x
1118-2E: 6x
1118-3E: 9x

1028: 0x
1028-2E: 0x
1028-4E: 0x

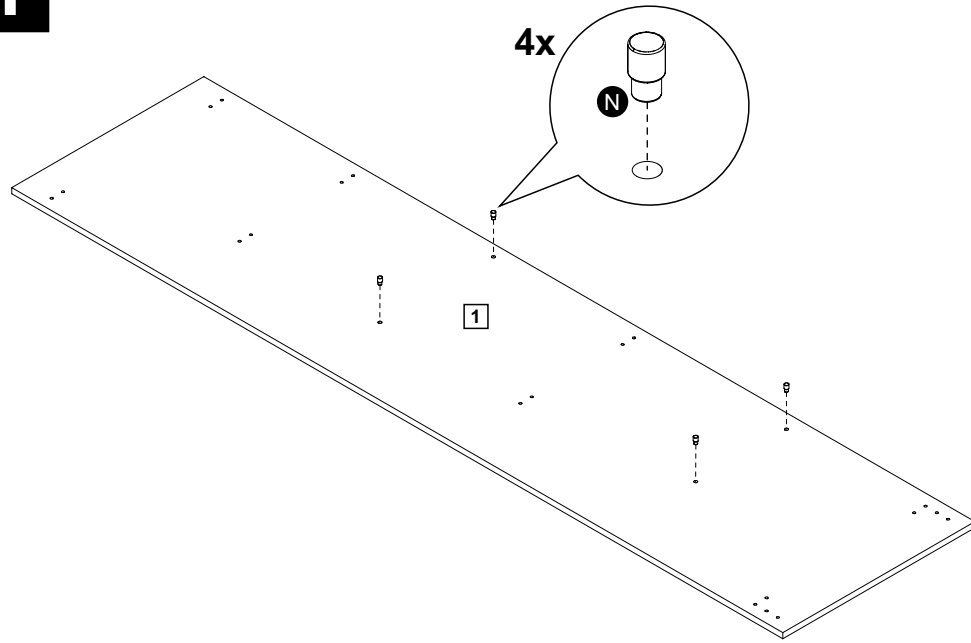
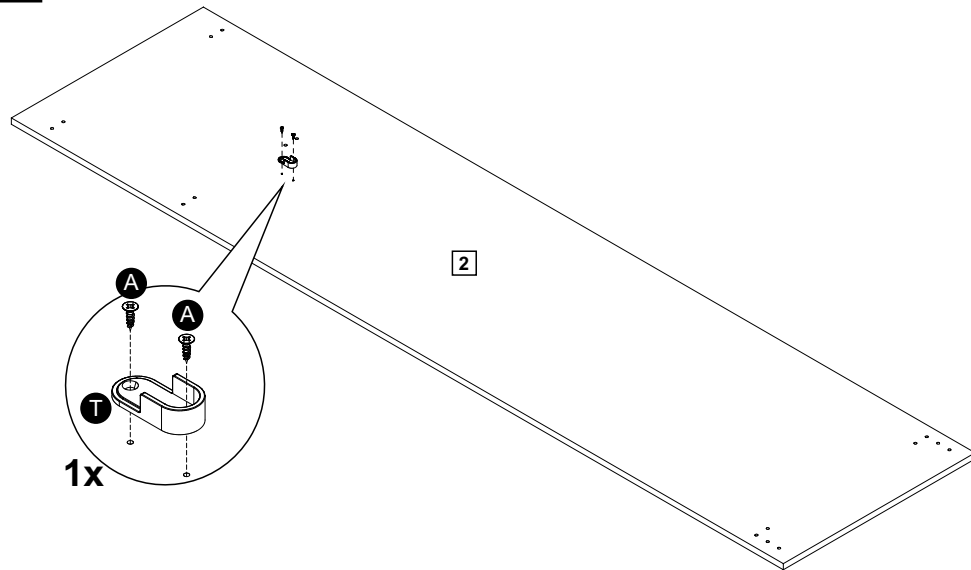
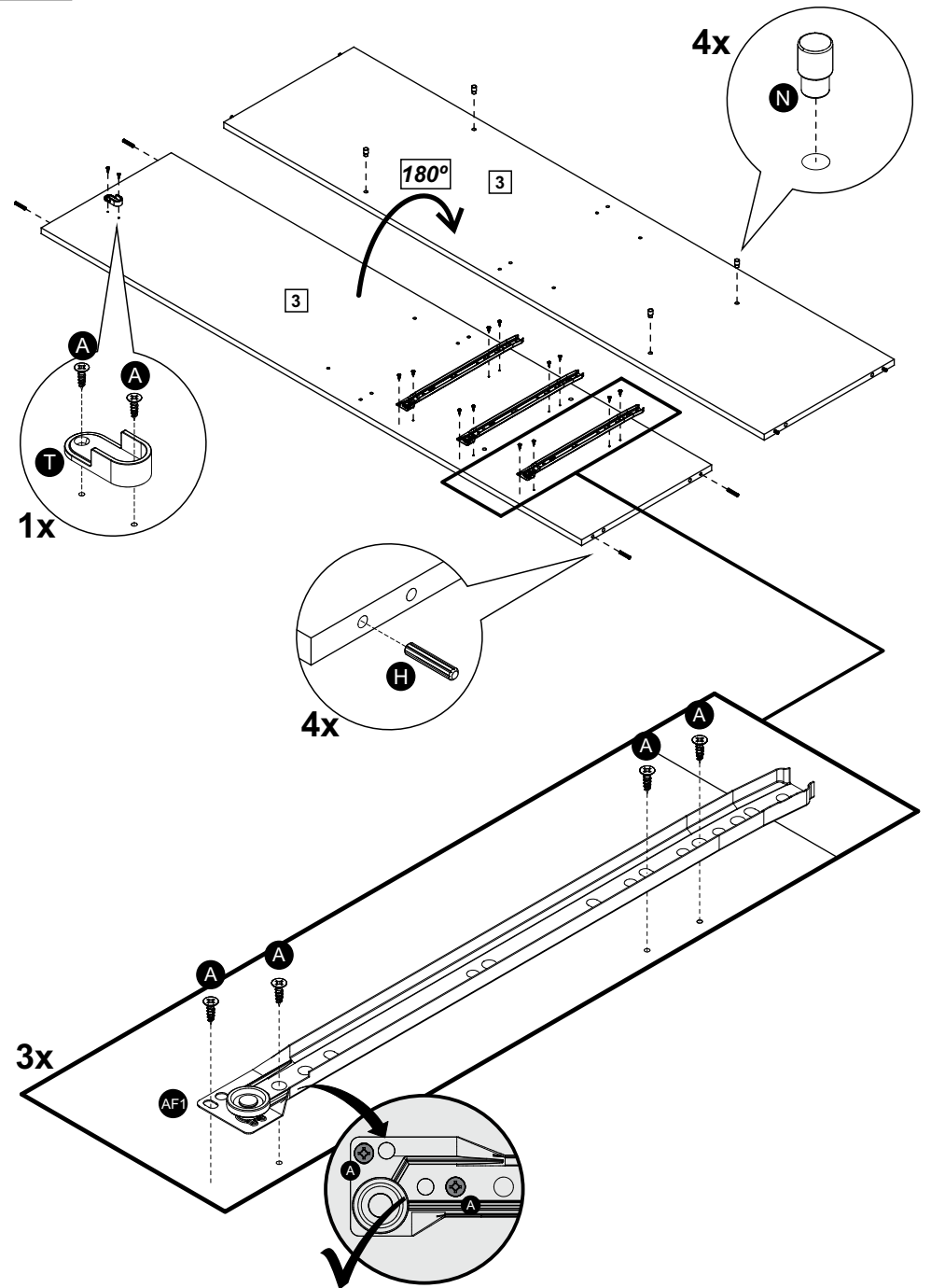
1**2****3**

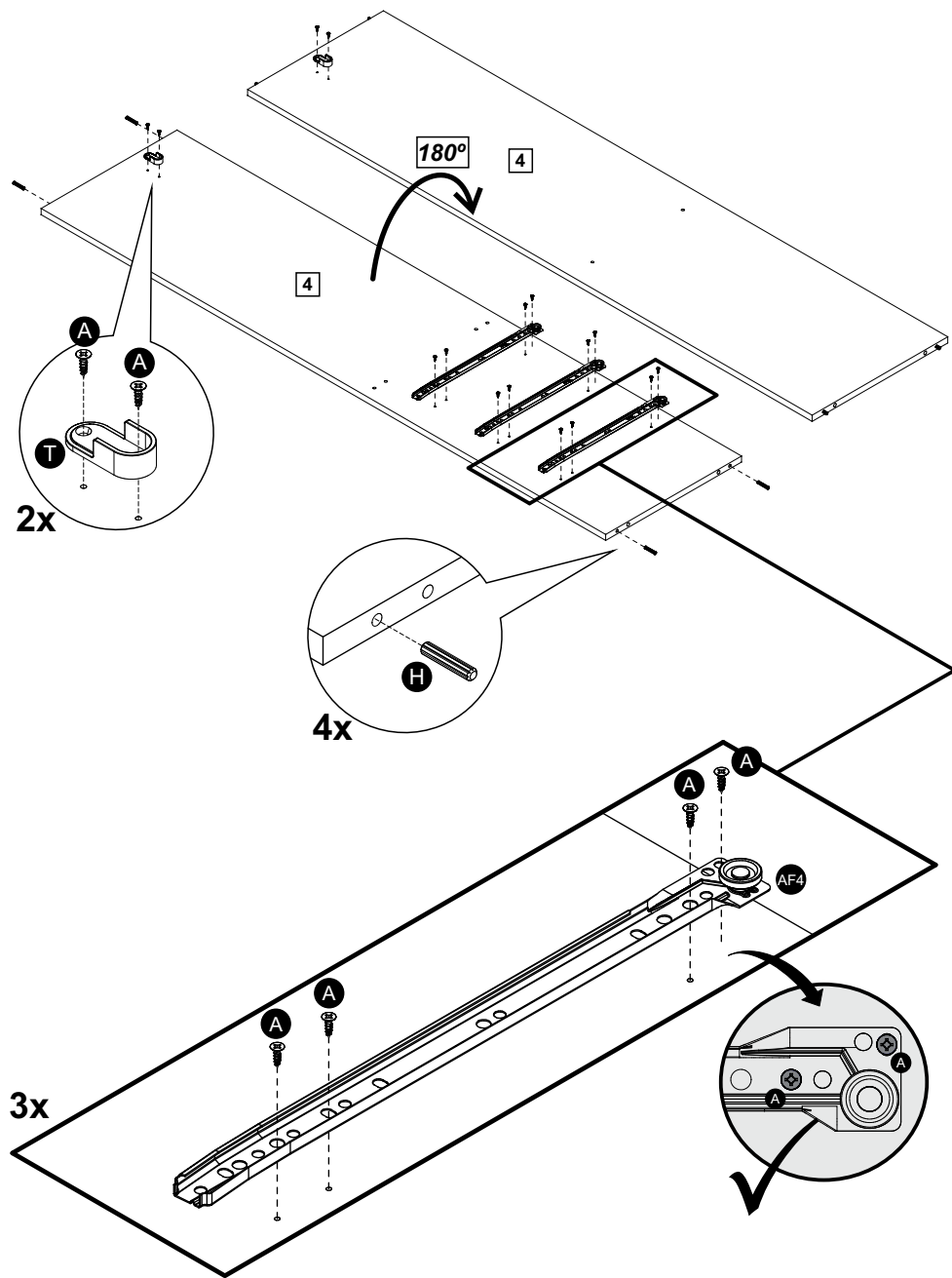
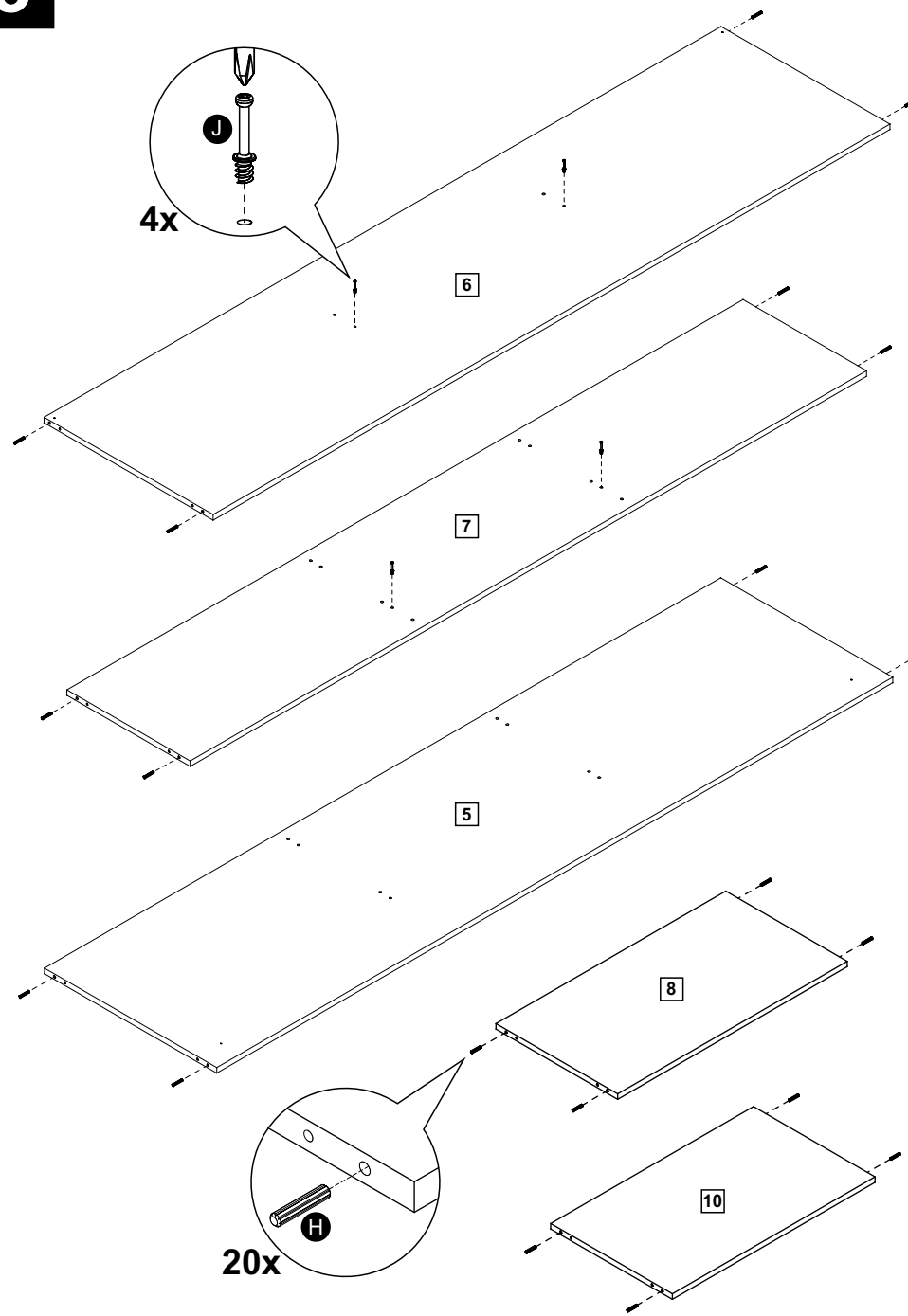
4**5**

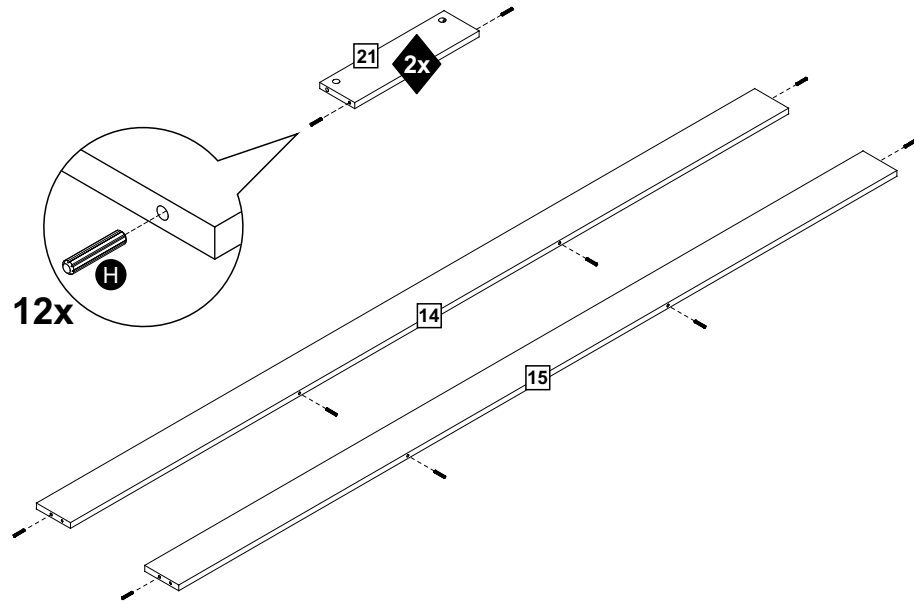
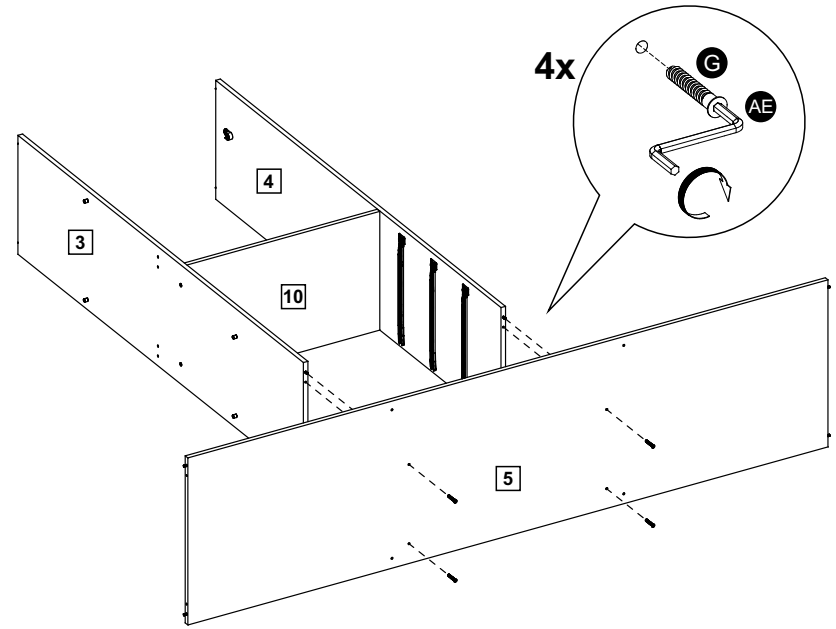
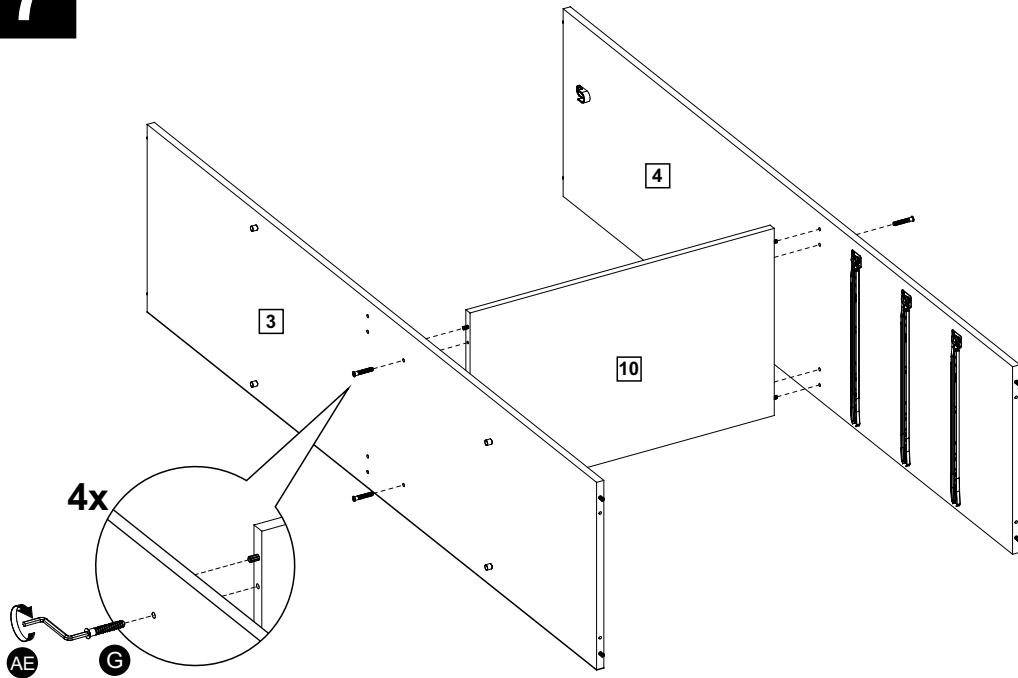
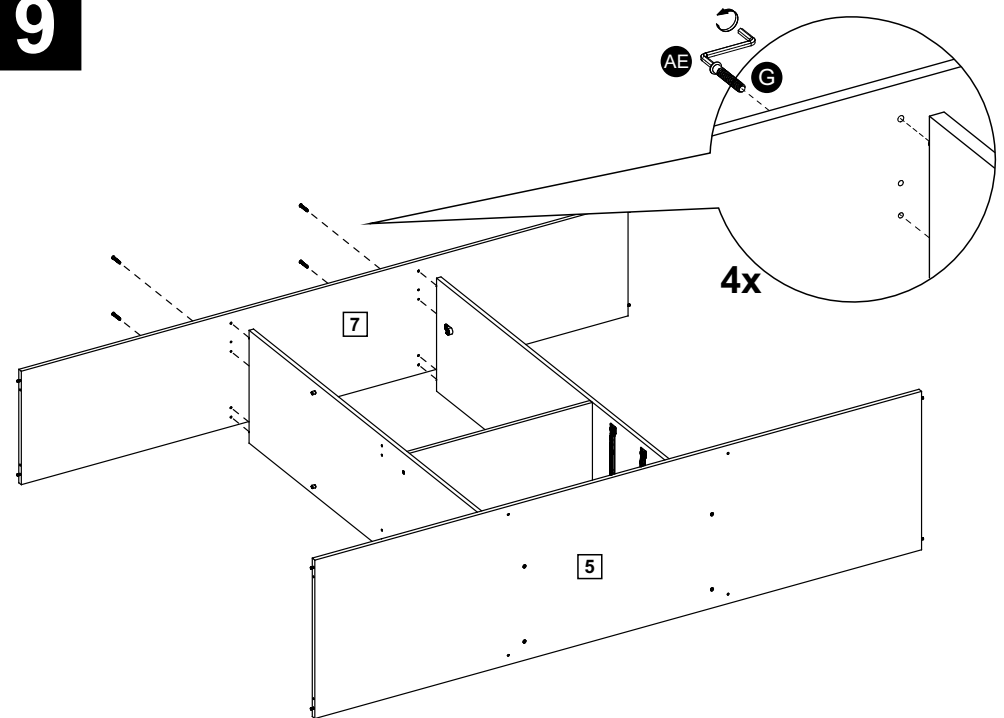
6**8****7****9**

10

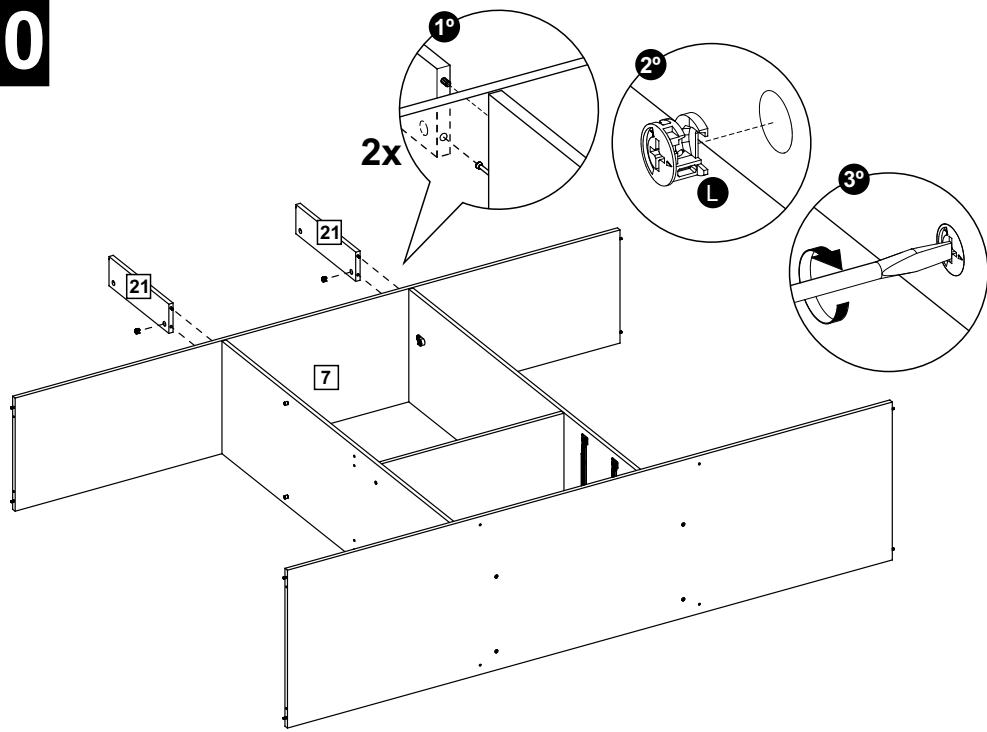

12

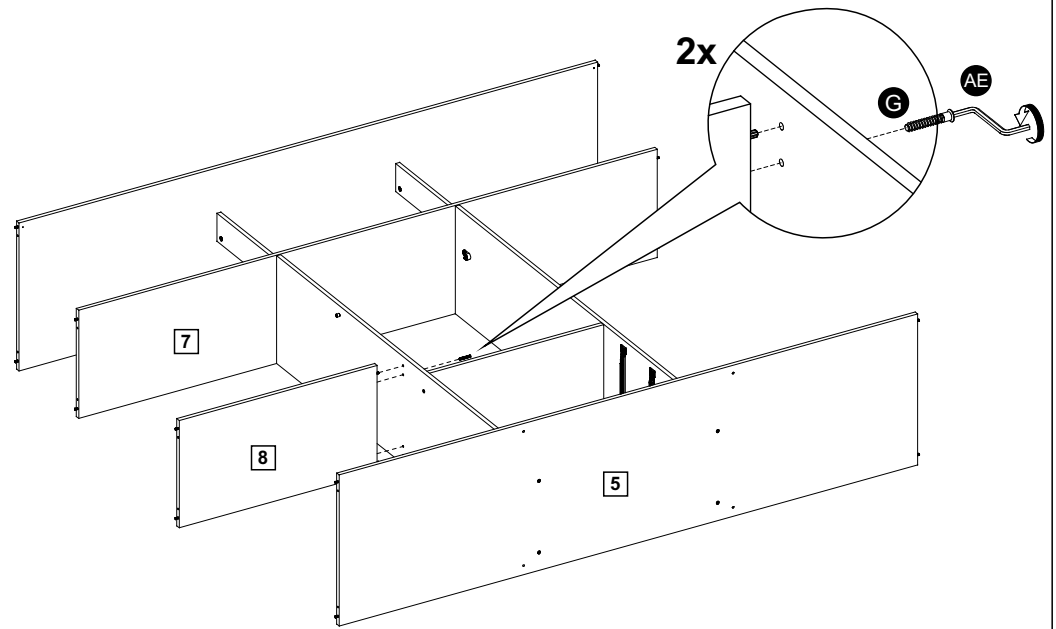

11

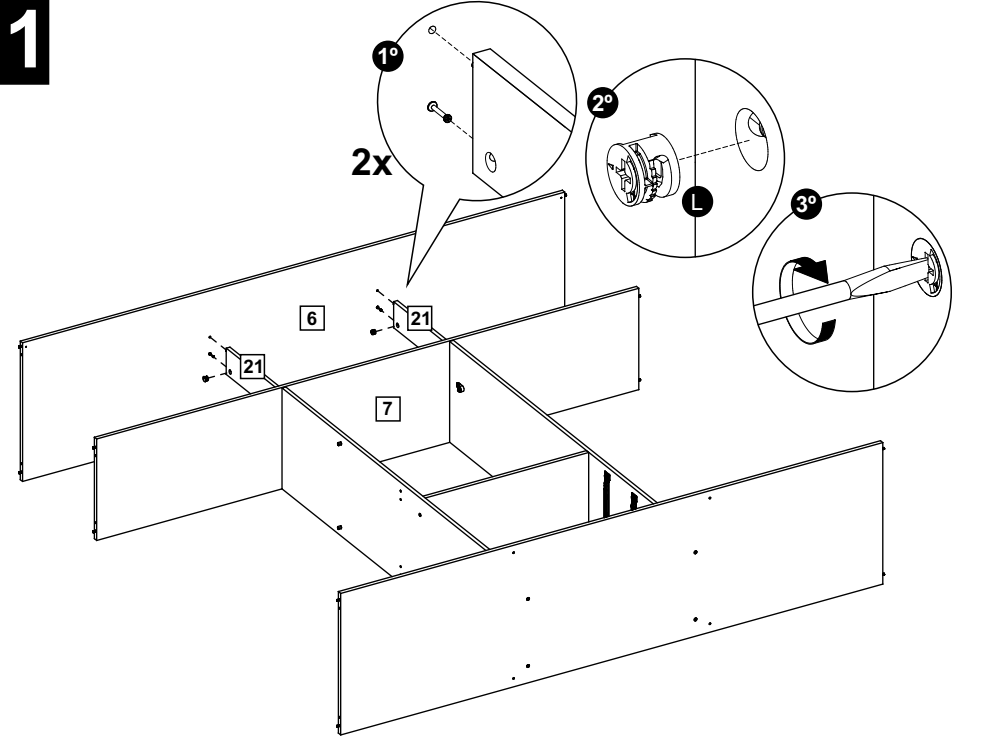

13

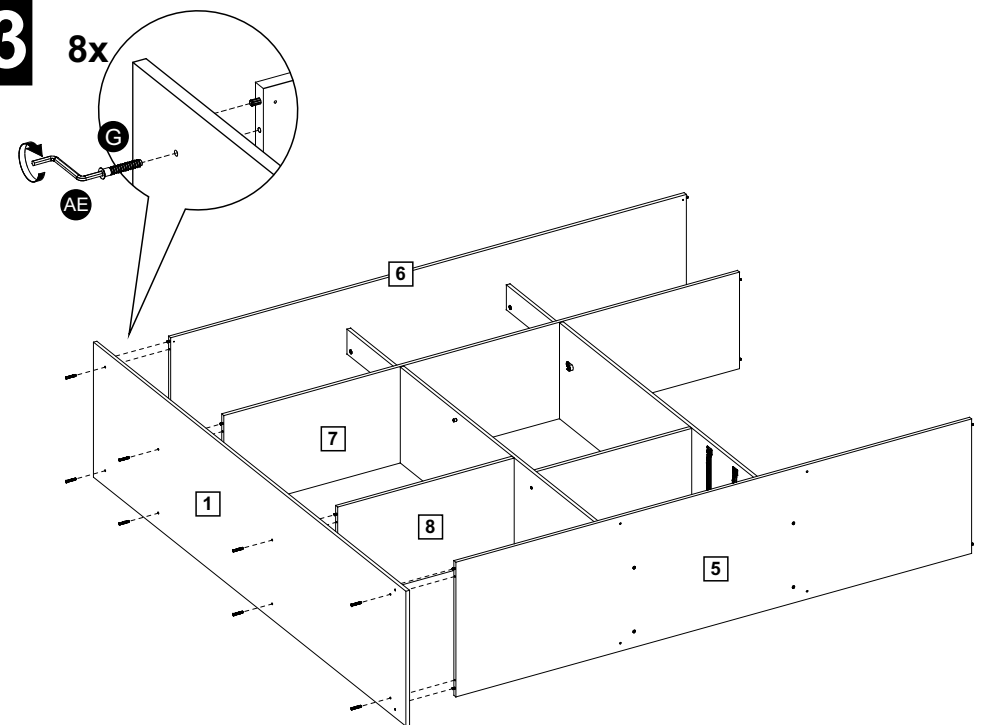

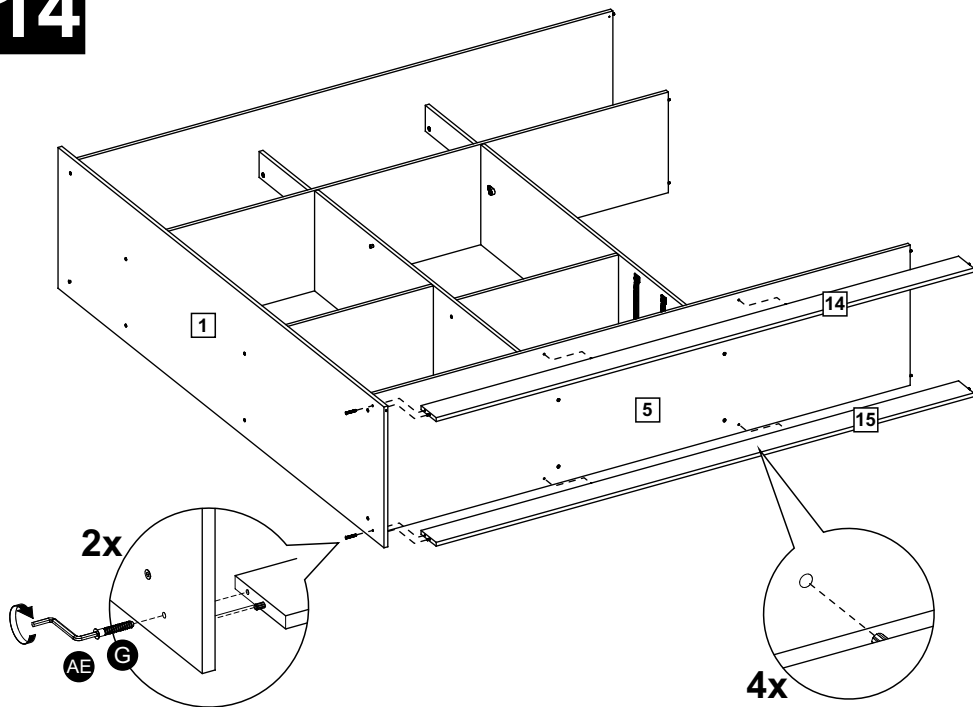
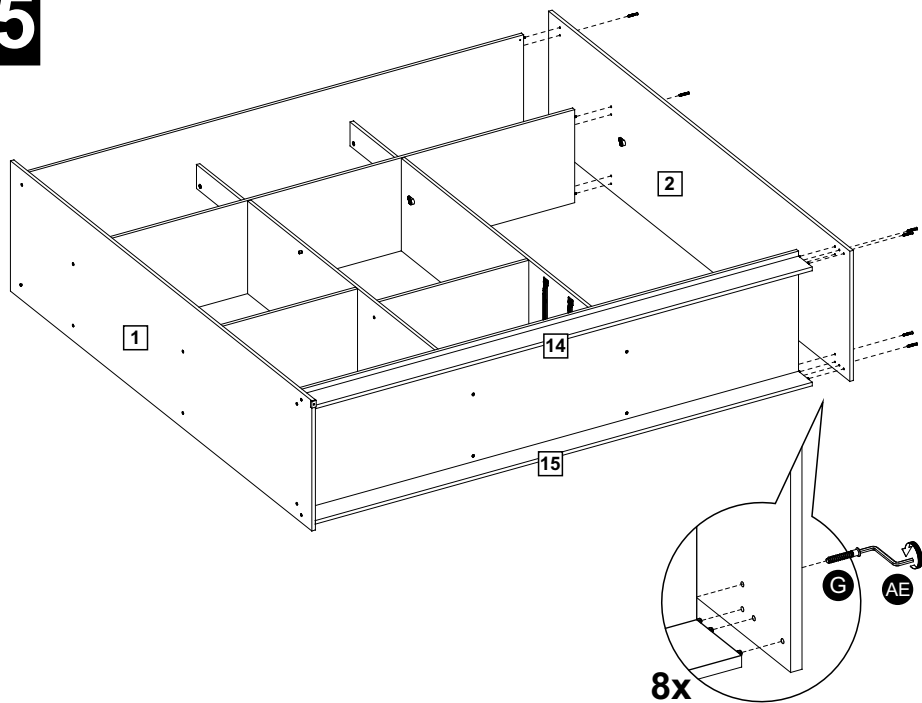
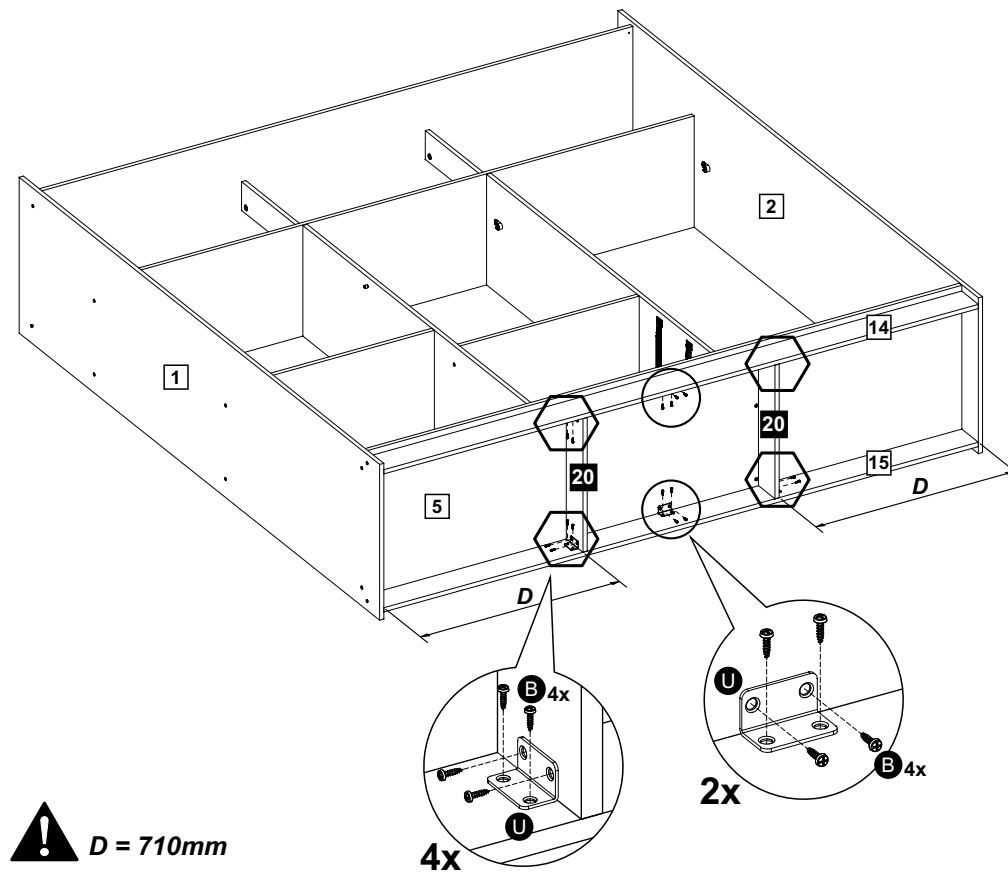
14**15****16**

! $D = 710\text{mm}$

ATENÇÃO - ATENCIÓN - ATTENTION

Para modelo com pés, verificar esquema que acompanha o Kit Pés antes de dar sequência na montagem.

Para modelo con pies, comprobar el esquema que acompaña el Kit Pies antes de dar secuencia en el montaje.

For model with feet, check the assembly instructions accompanying the feet kit before proceeding with the assembly.

17

ATENÇÃO - ATENCIÓN - ATTENTION

Se adquirido a opção com Kit Pés, desconsiderar o passo 17.
Se has comprado la opción con patas, no considerar lo paso 17.
If you bought the product with feet, skip step 17.

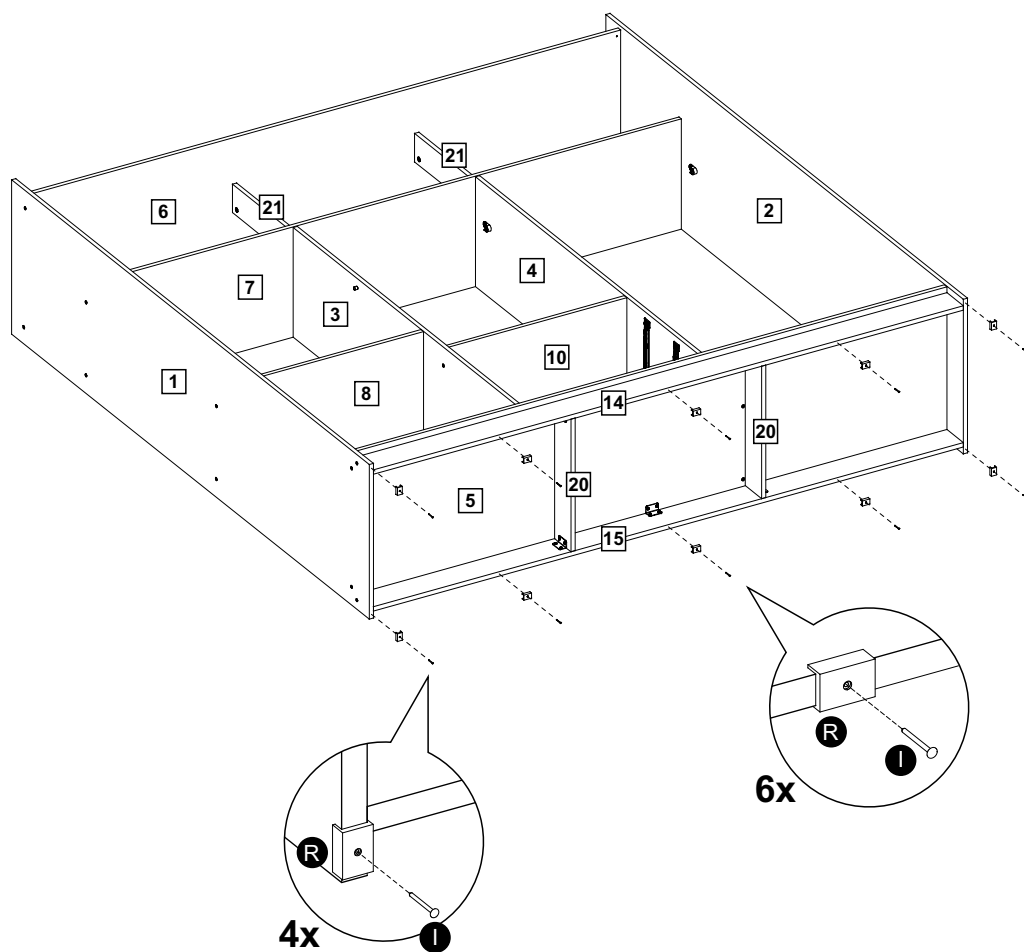

18

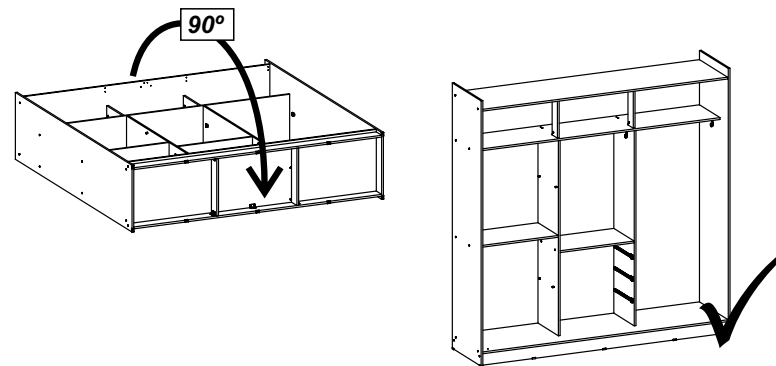

19

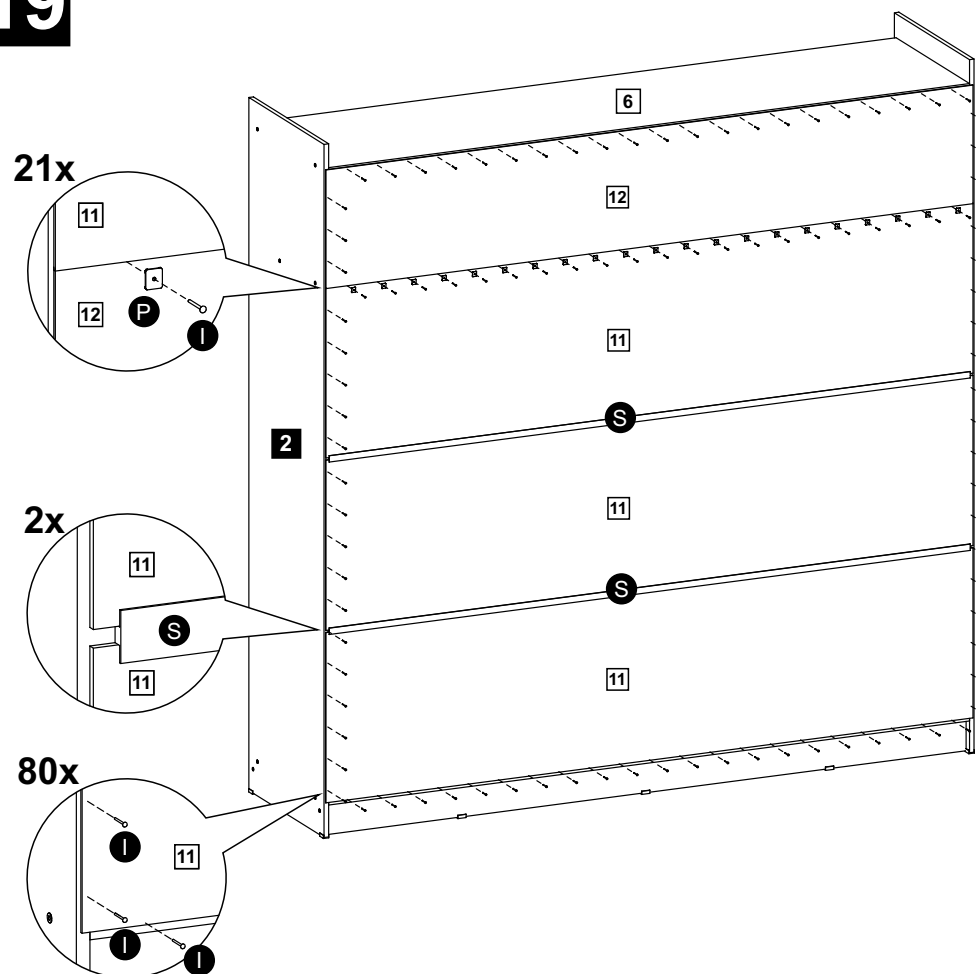

20

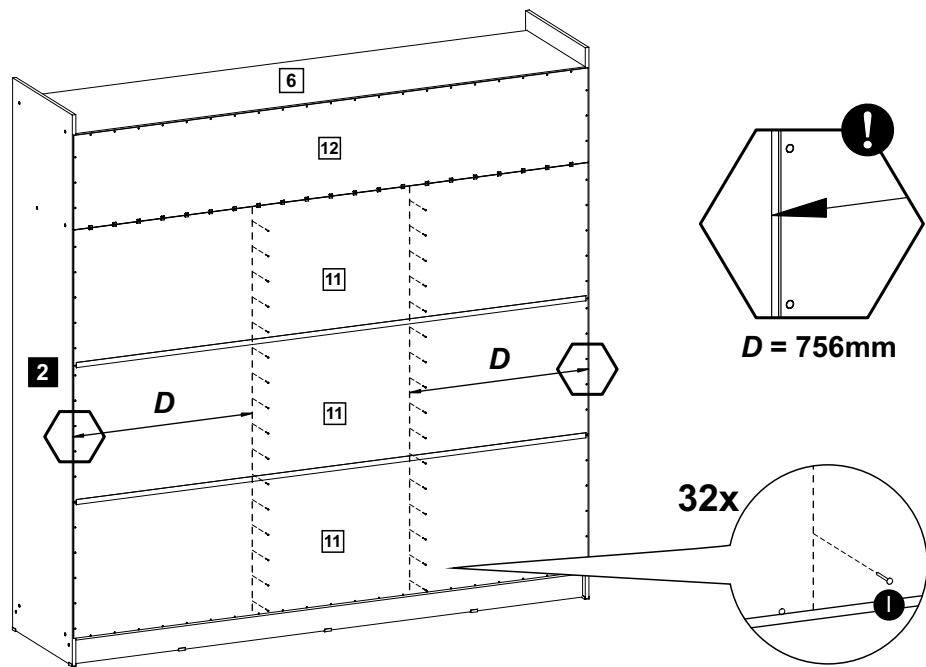

21

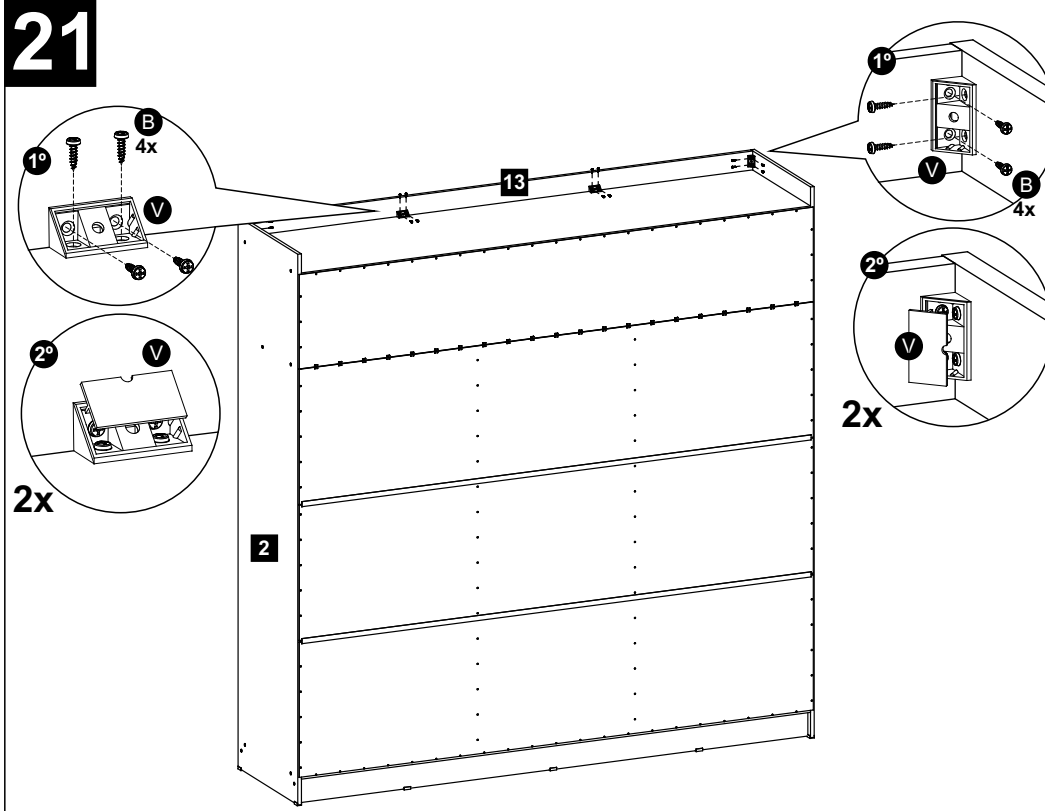

22- 3x

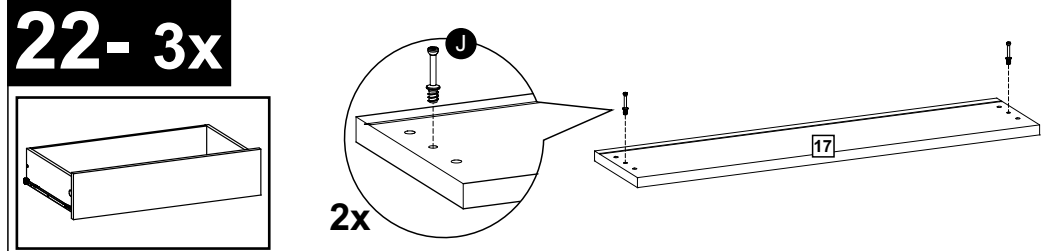

23- 6x

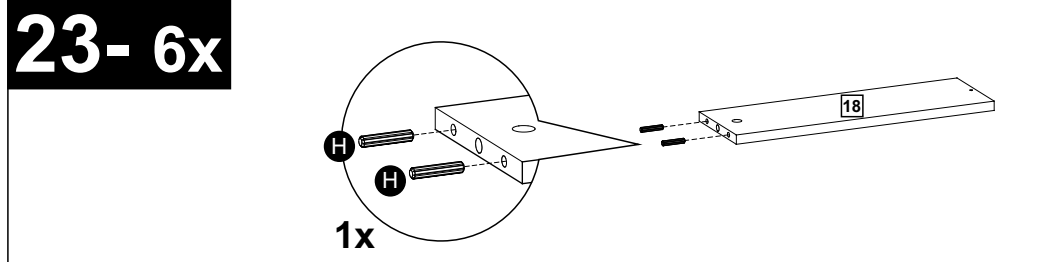

24- 3x

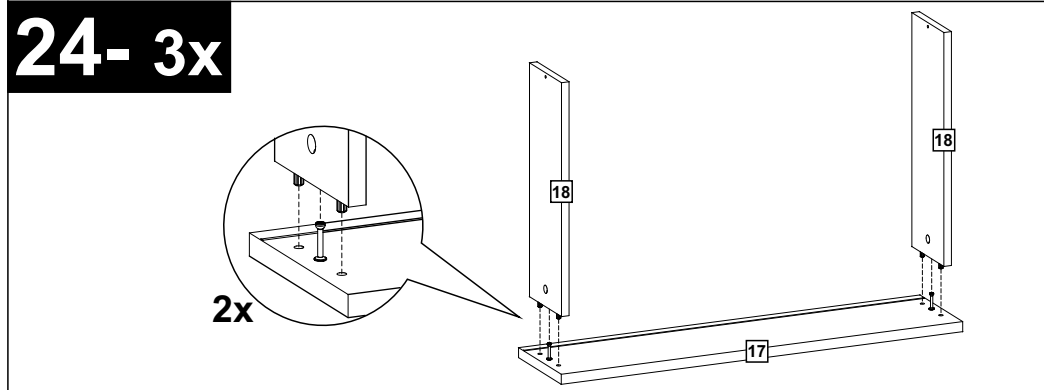

25- 3x

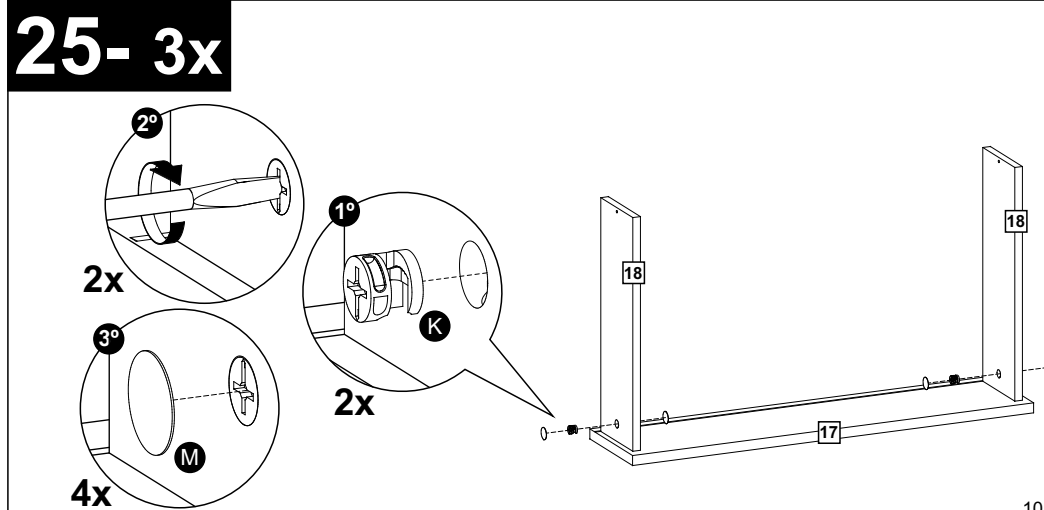

26- 3x

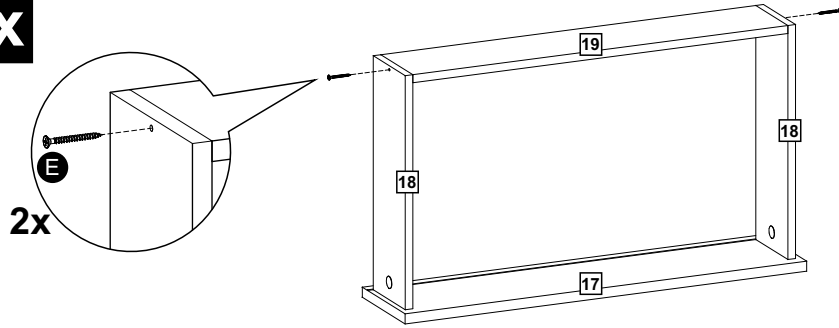

27- 3x

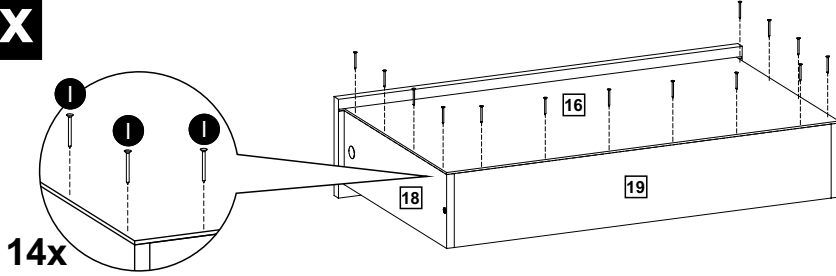

28- 3x

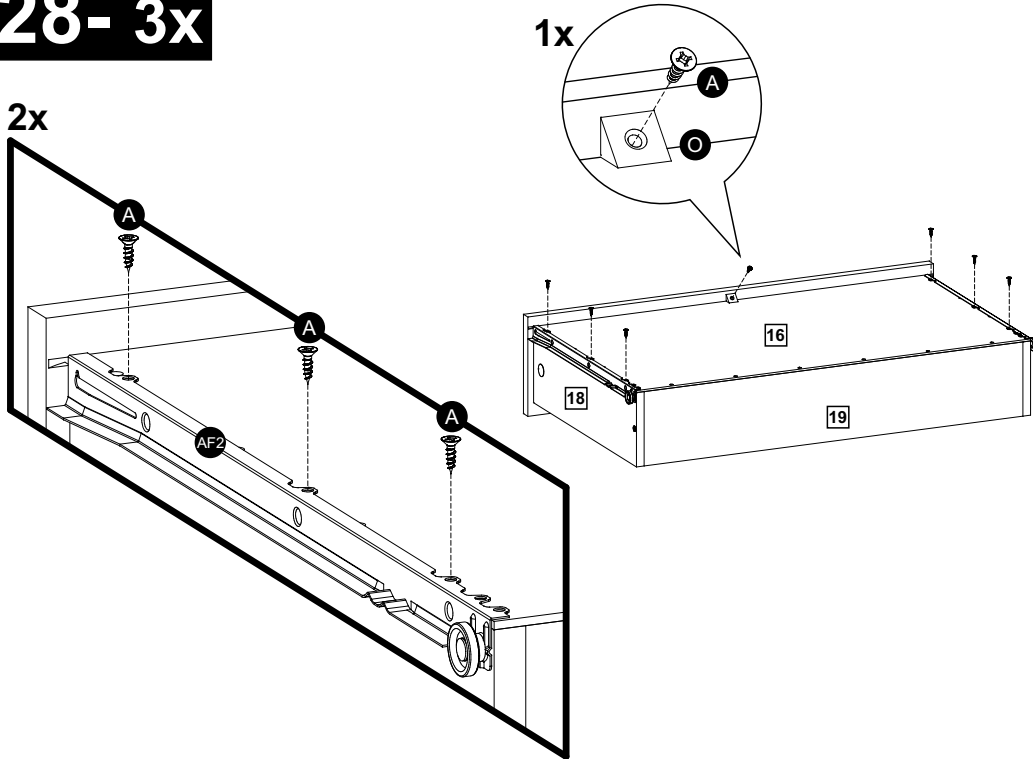

29

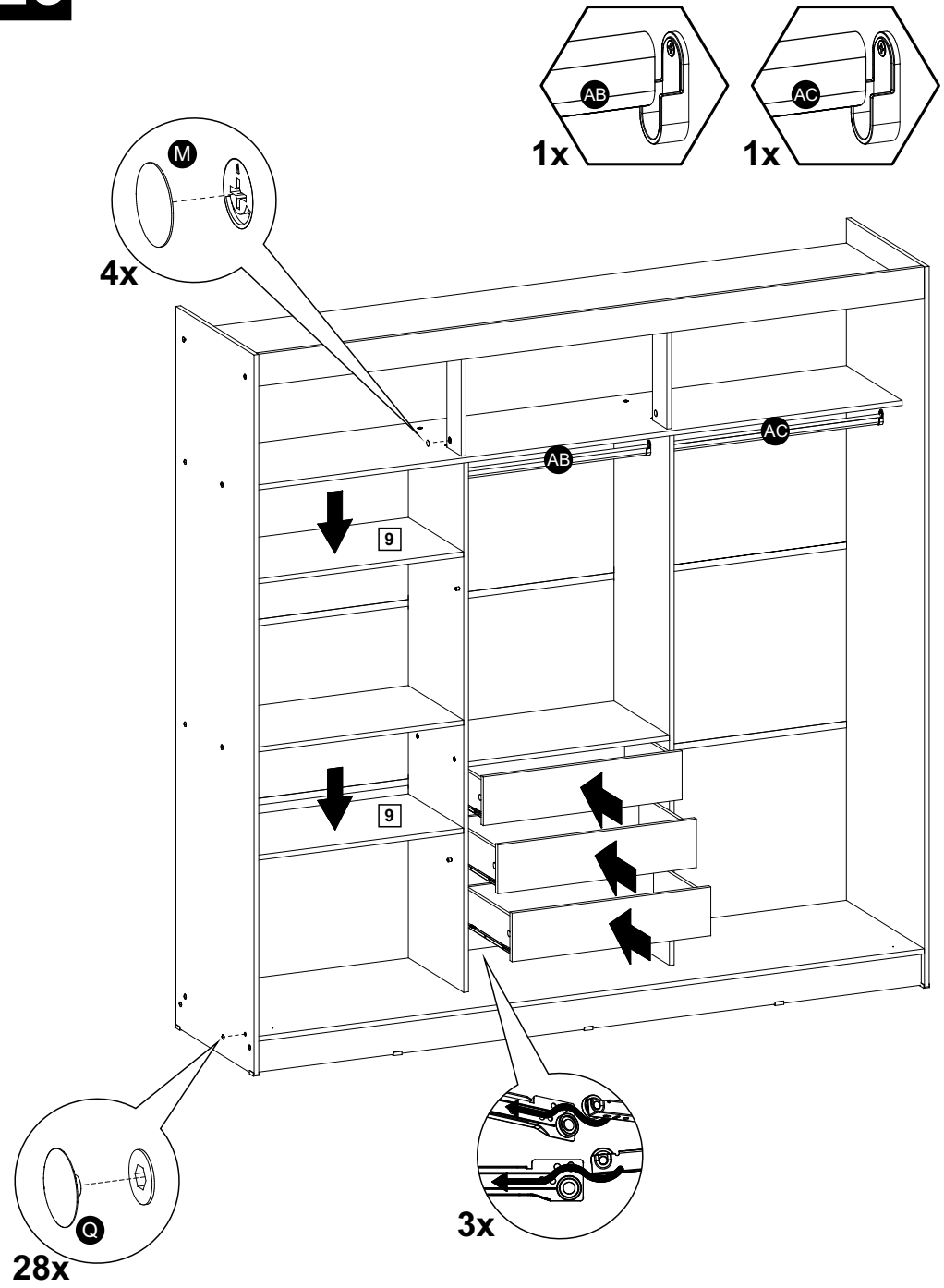

ATENÇÃO - ATENCIÓN - ATTENTION

Se você adquiriu o Roupeiro 1018 ou 1118 - 3 PORTAS, vá para a página 12 e siga os passos 30 à 37.

Si ha comprado el Armario 1018 o 1118 - 3 PUERTAS, vaya a la página 12 y siga los pasos 30 a 37.

If you purchased the Wardrobe 1018 or 1118 - 3 DOORS, go to page 12 and follow steps 30 to 37.

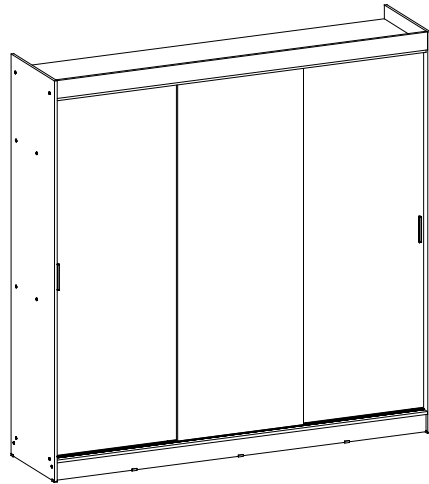

ATENÇÃO - ATENCIÓN - ATTENTION

Se você adquiriu o Roupeiro 1028 - 4 PORTAS, vá para a página 15 e siga os passos 38 à 44.

Si ha comprado el Armario 1028 - 4 PUERTAS, vaya a la página 15 y siga los pasos 38 a 44.

If you purchased the Wardrobe 1028 - 4 DOORS, go to page 15 and follow steps 38 to 44.

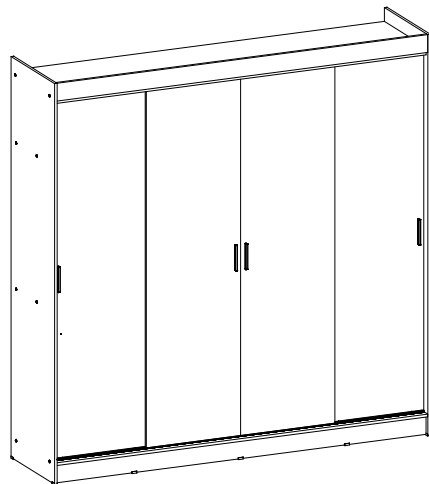

30

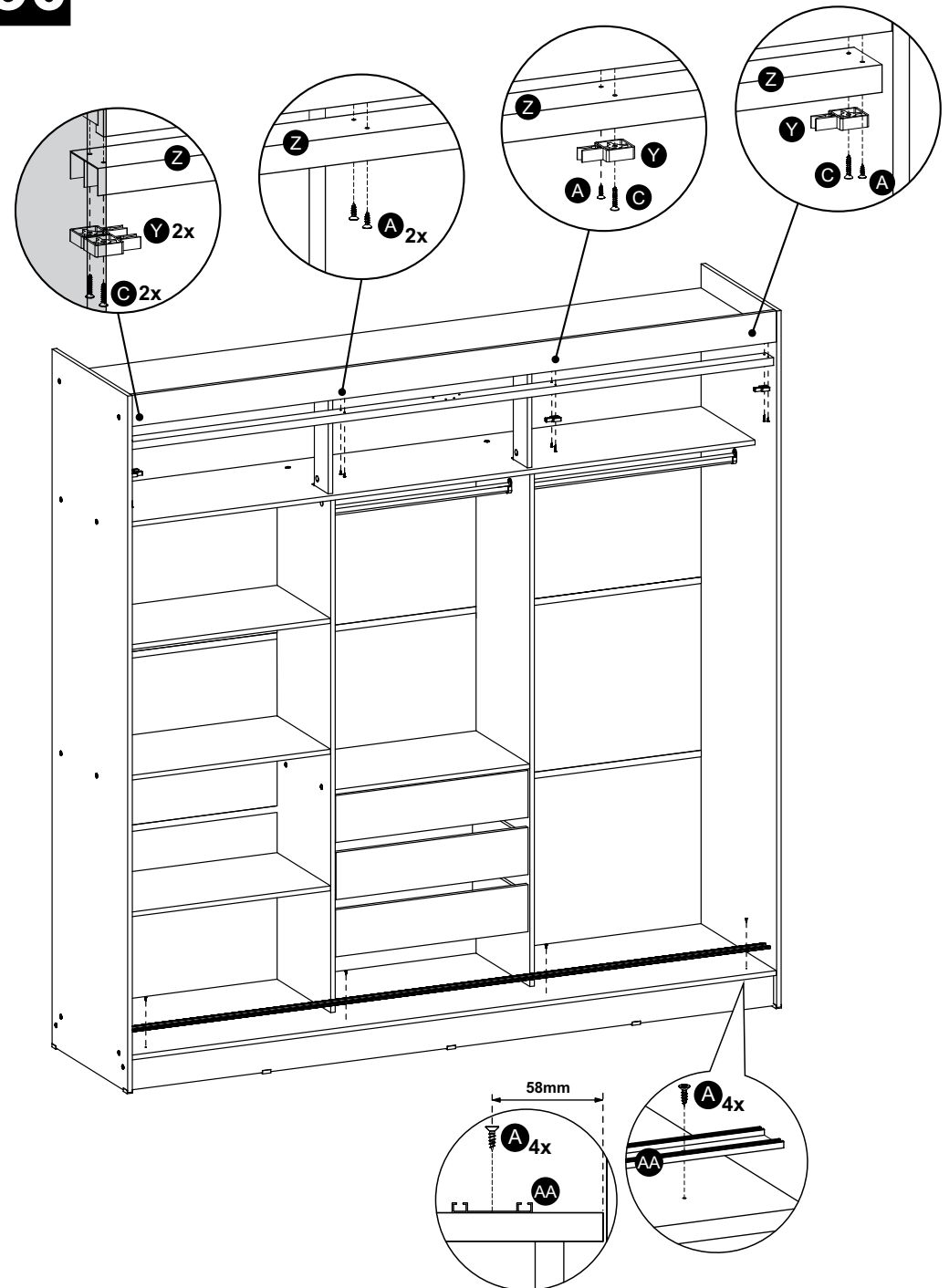

31- 3x

ATENÇÃO - ATENCIÓN - ATTENTION

Trave as roldanas dos carrinhos antes de fixa-los nas portas.
 Bloquee las poleas del carro antes de asegurarlas a las puertas
 Lock the cart pulleys before securing them to the doors

Gire o parafuso para cima
 Gire el tornillo hacia arriba
 Turn up the screw

Pressione a roldana para cima até ela travar
 Presione las poleas del carro hasta que se bloquee
 Press the cart pulleys until it locks

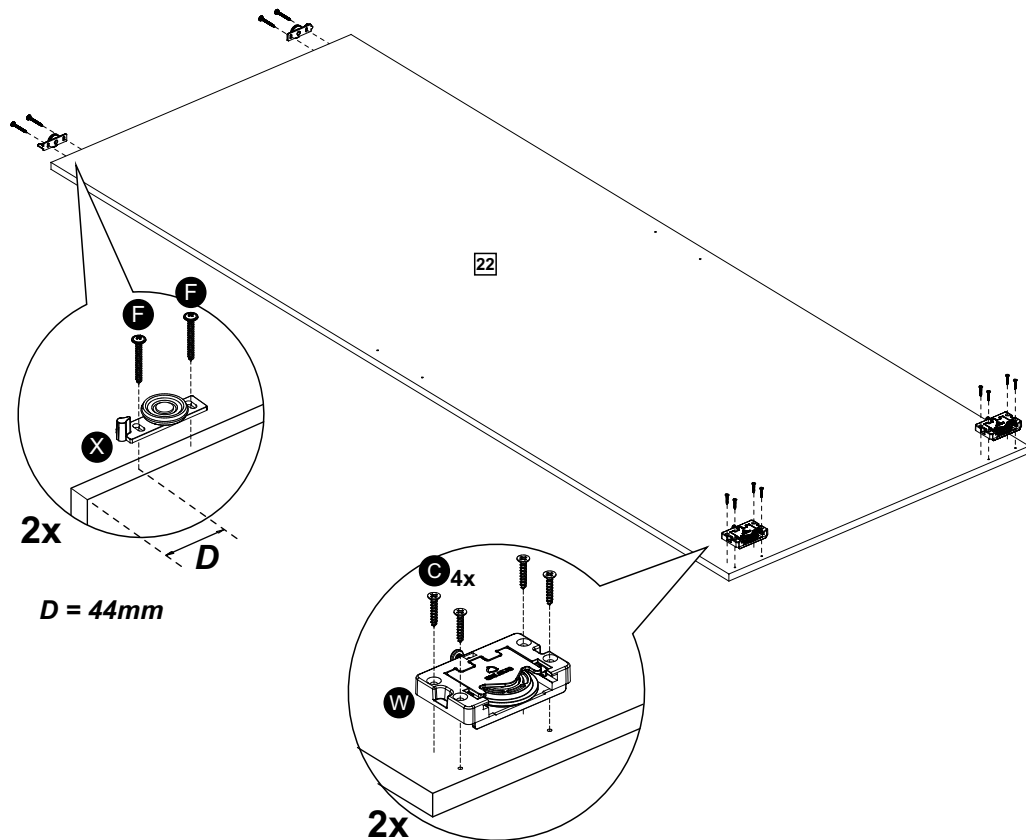
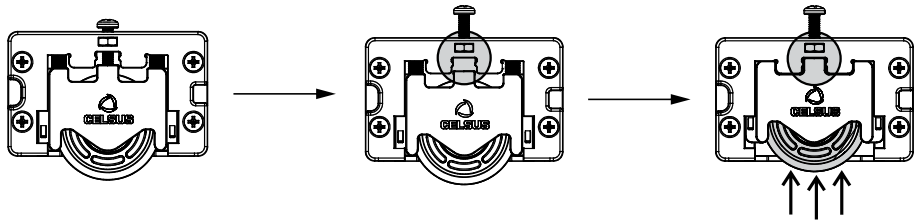

32

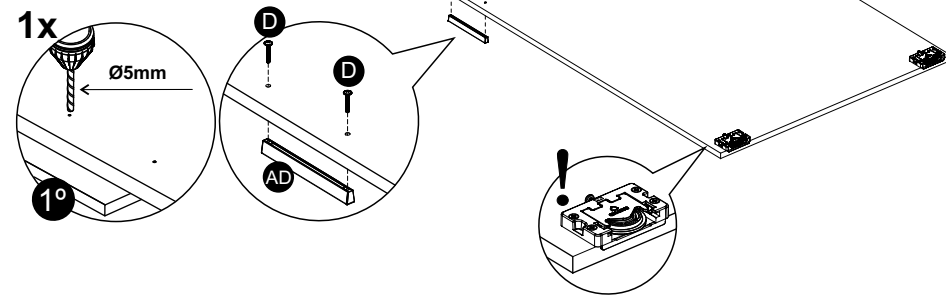

33

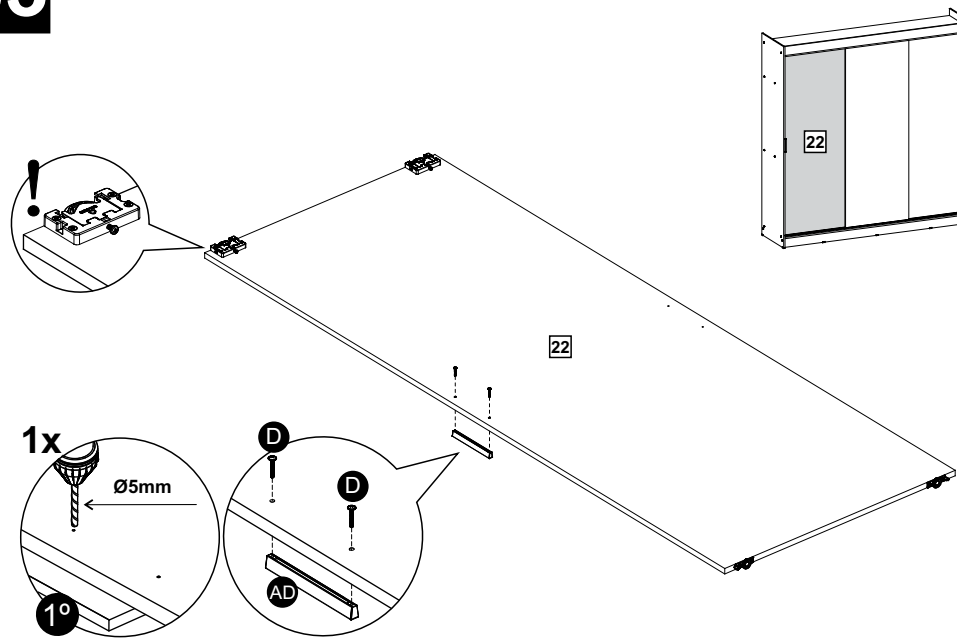

34

1018-1E

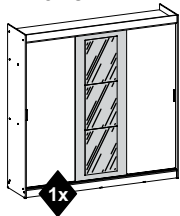

1018-2E

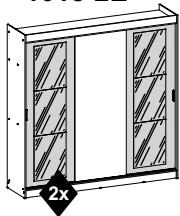

1018-3E

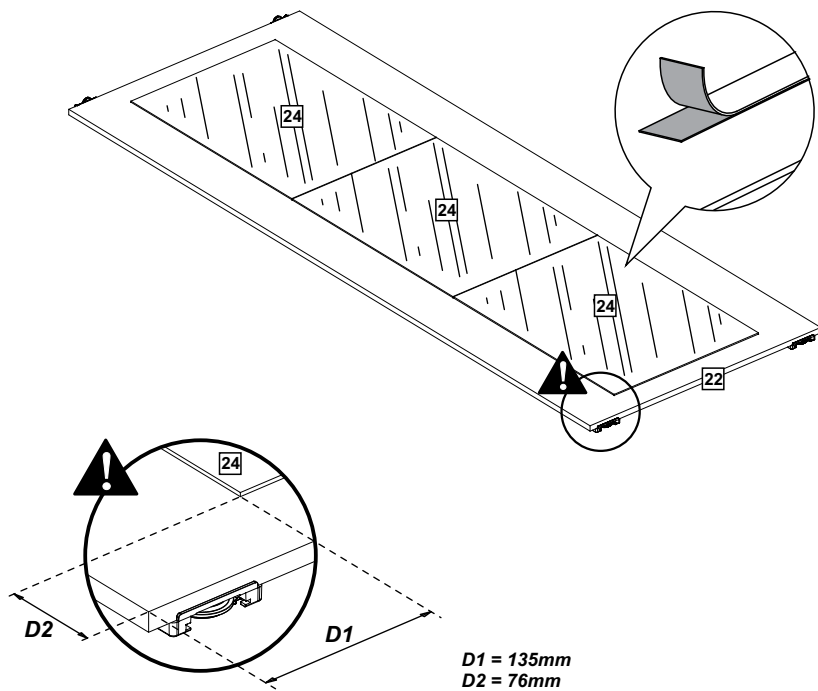
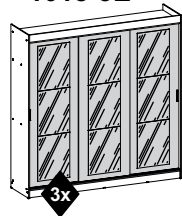

35

1118-1E

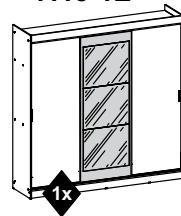

1118-2E

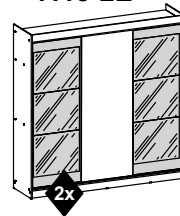

1118-3E

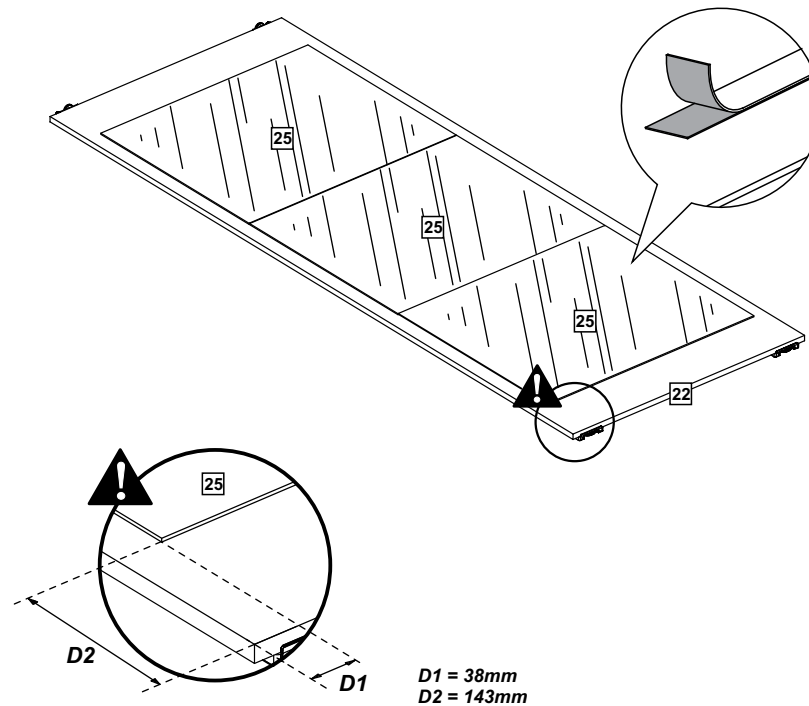
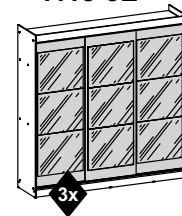

Utilize o QR code para acessar o vídeo explicativo da preparação e fixação dos espelhos.

Utilice el código QR para acceder al vídeo que explica la preparación y fijación de los espejos.

Use the QR Code to access the explanatory video on preparing and fixing the mirrors.



cdn.madesa.com/mont/ESPELHOS



Utilize o QR code para acessar o vídeo explicativo da preparação e fixação dos espelhos.

Utilice el código QR para acceder al vídeo que explica la preparación y fijación de los espejos.

Use the QR Code to access the explanatory video on preparing and fixing the mirrors.



cdn.madesa.com/mont/ESPELHOS

37

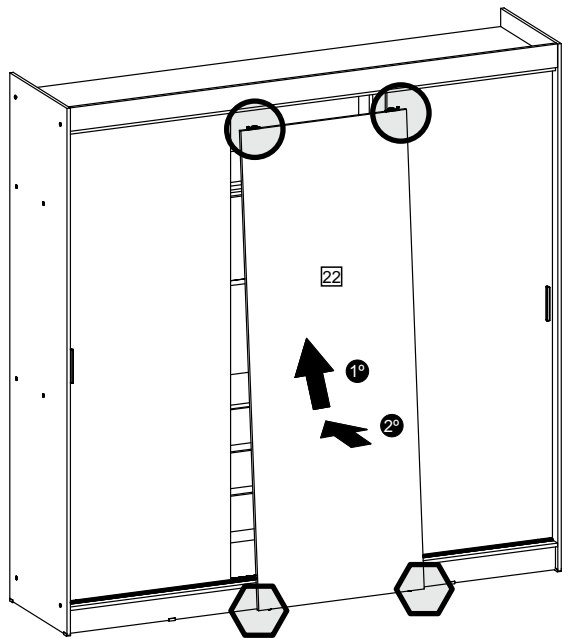
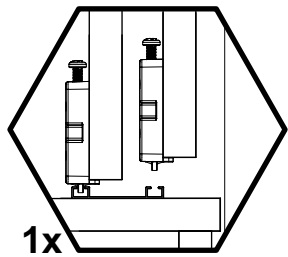
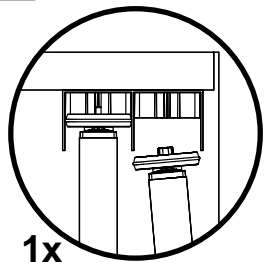

36

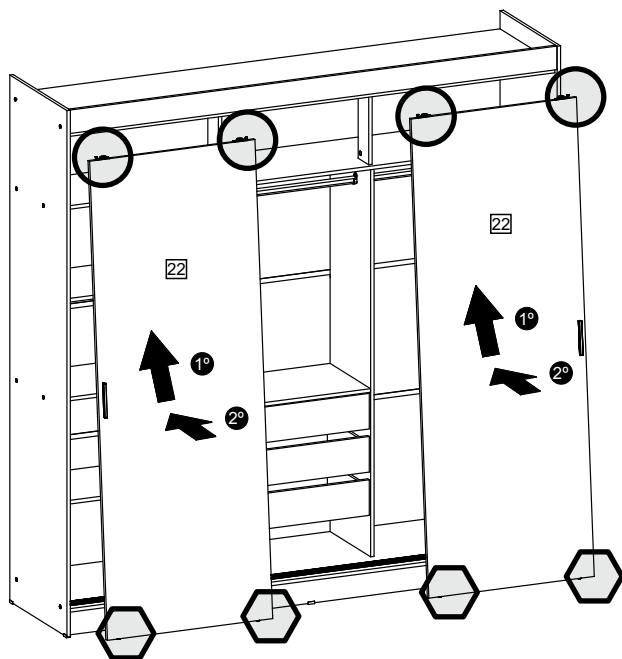
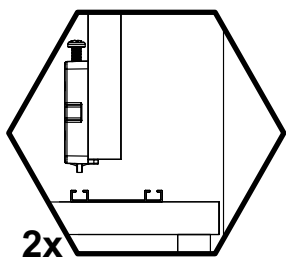
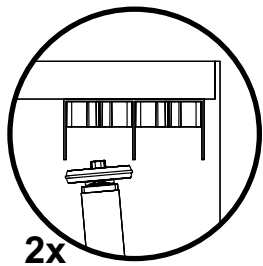

38

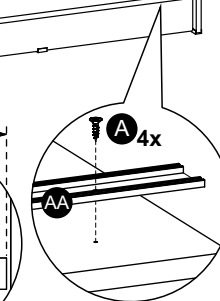
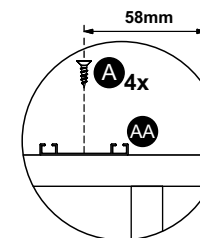
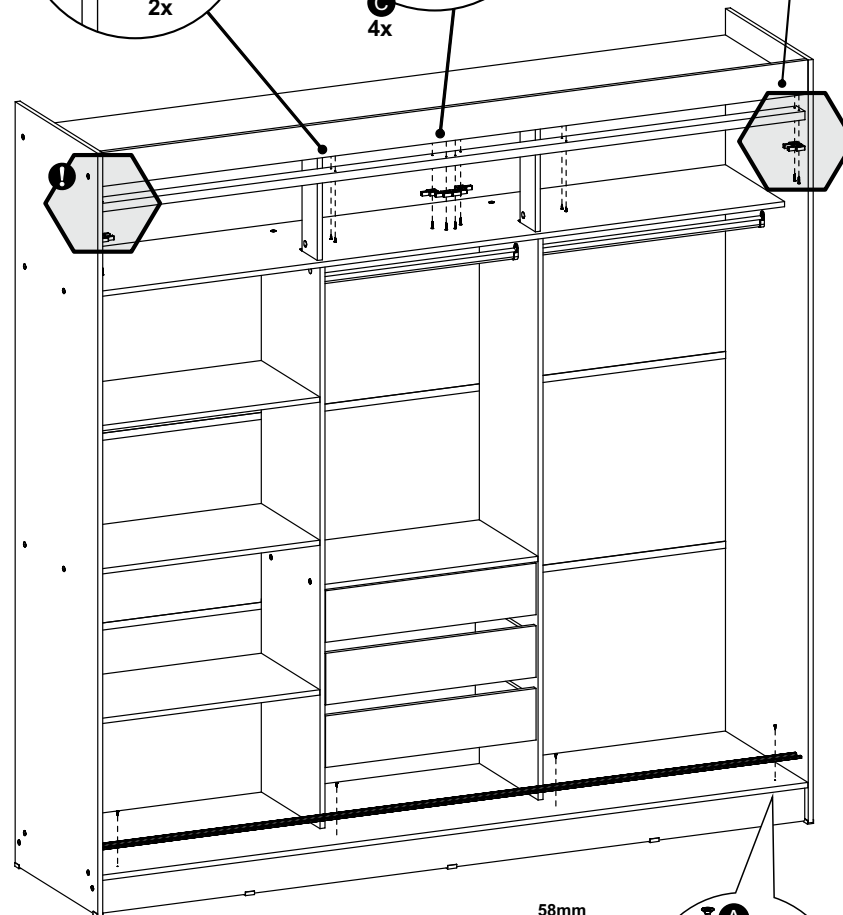
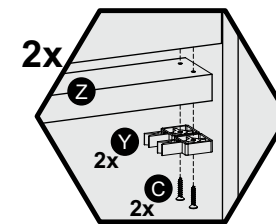
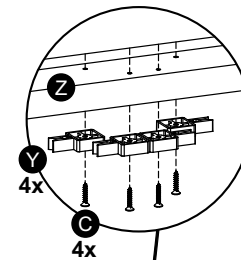
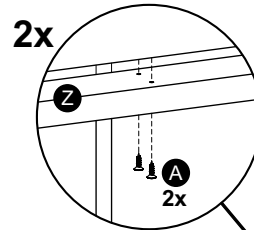

39- 4x

ATENÇÃO - ATENCIÓN - ATTENTION

Trave as roldanas dos carrinhos antes de fixa-los nas portas.
 Bloquee las poleas del carro antes de asegurarlas a las puertas
 Lock the cart pulleys before securing them to the doors

Gire o parafuso para cima
 Gire el tornillo hacia arriba
 Turn up the screw

Pressione a roldana para cima até ela travar
 Presione las poleas del carro hasta que se bloquee
 Press the cart pulleys until it locks

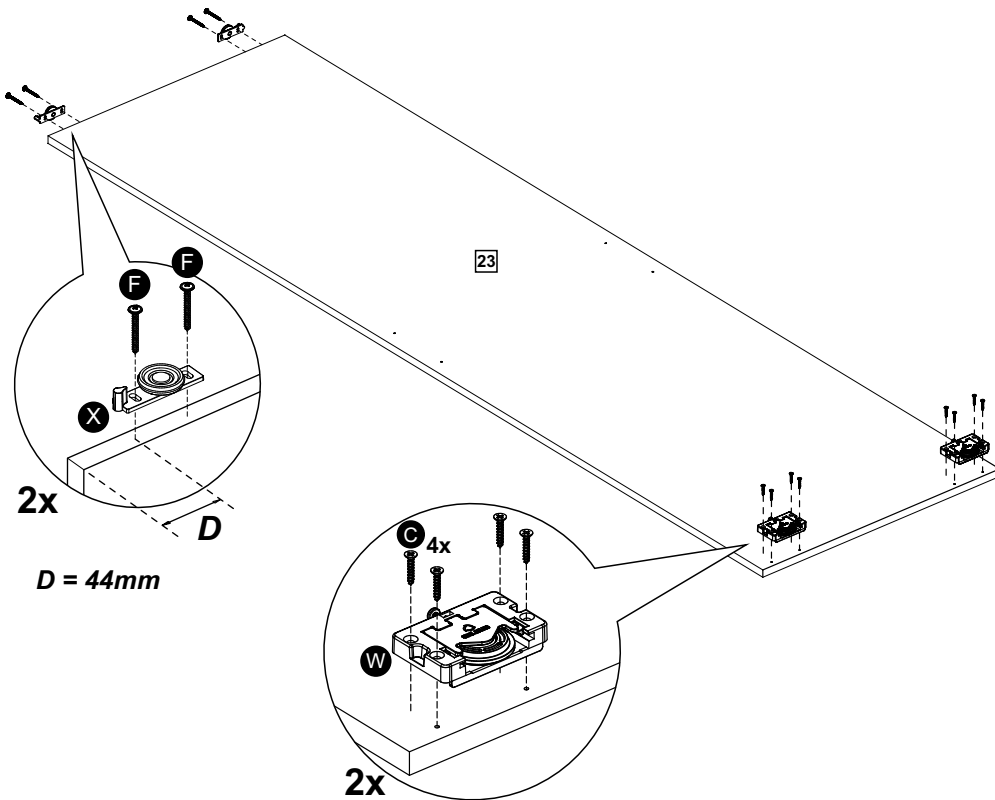
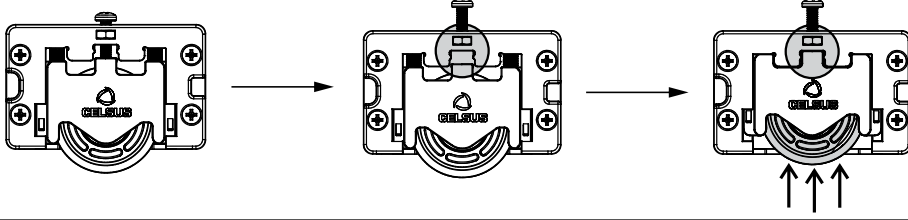

42

1028-2E

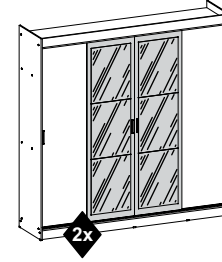

1028-4E

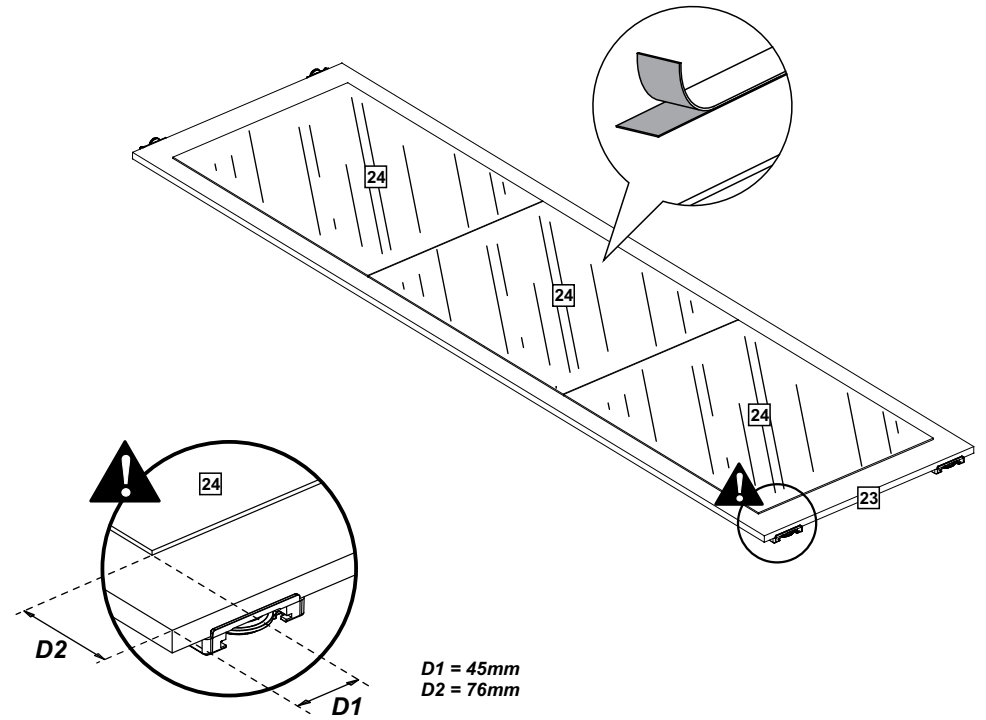
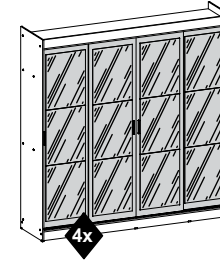

Utilize o QR code para acessar o vídeo explicativo da preparação e fixação dos espelhos.

Utilice el código QR para acceder al vídeo que explica la preparación y fijación de los espejos.

Use the QR Code to access the explanatory video on preparing and fixing the mirrors.



cdn.madesa.com/mont/ESPELHOS

40-2x

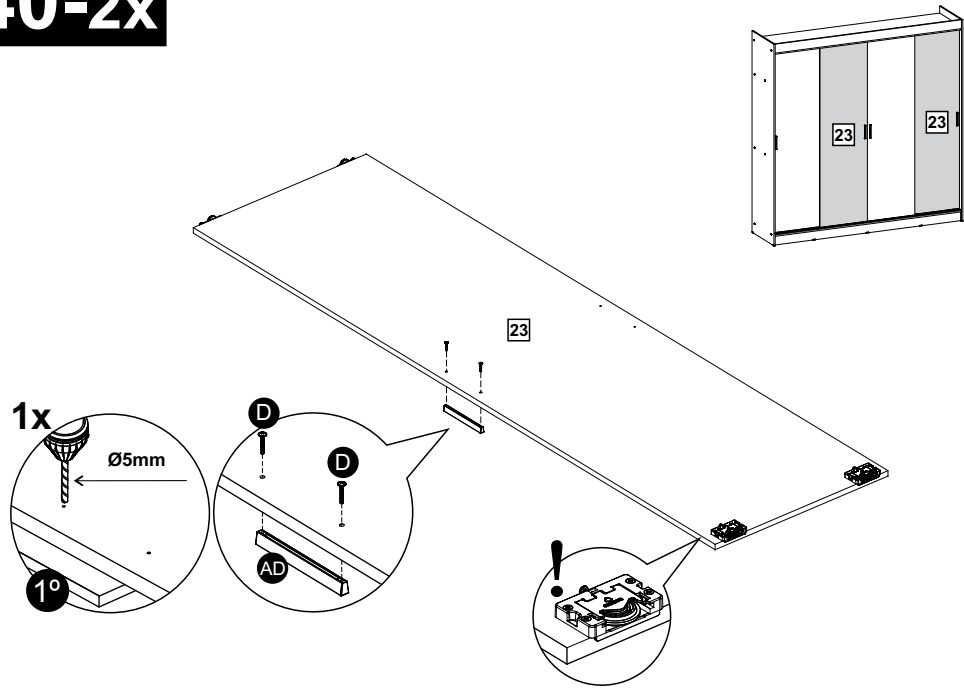

43

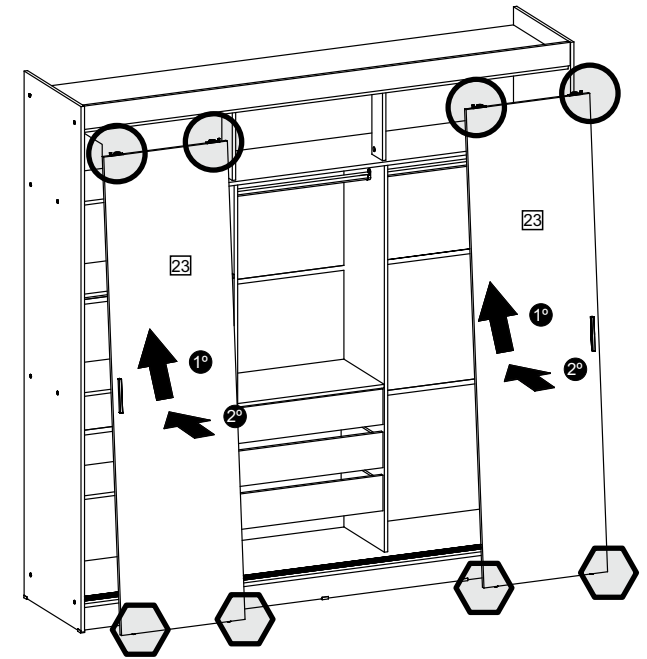
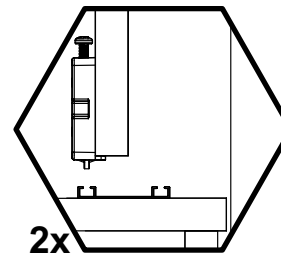
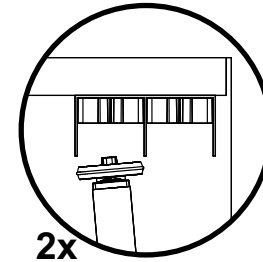

41-2x

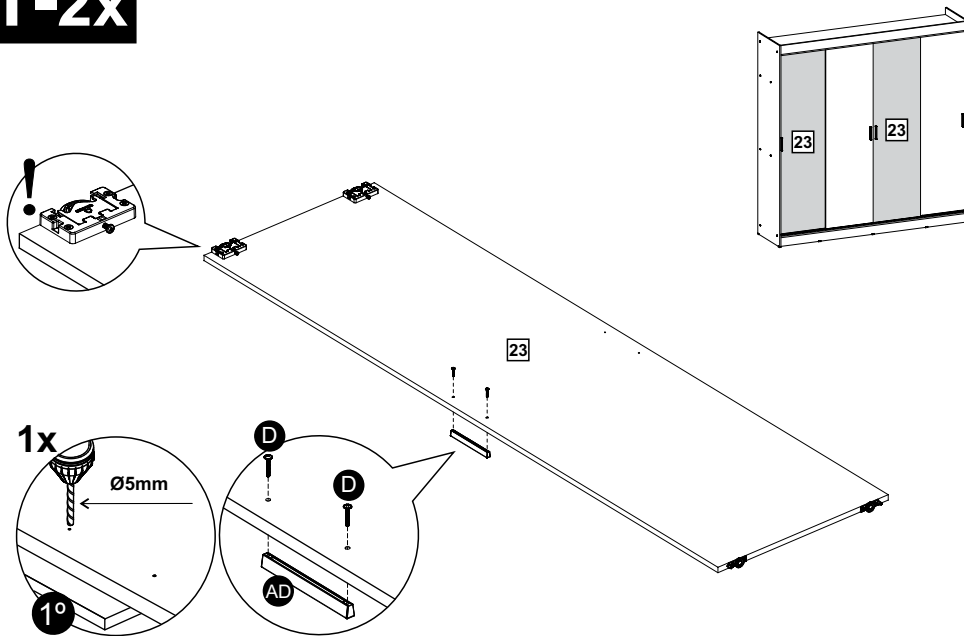

44

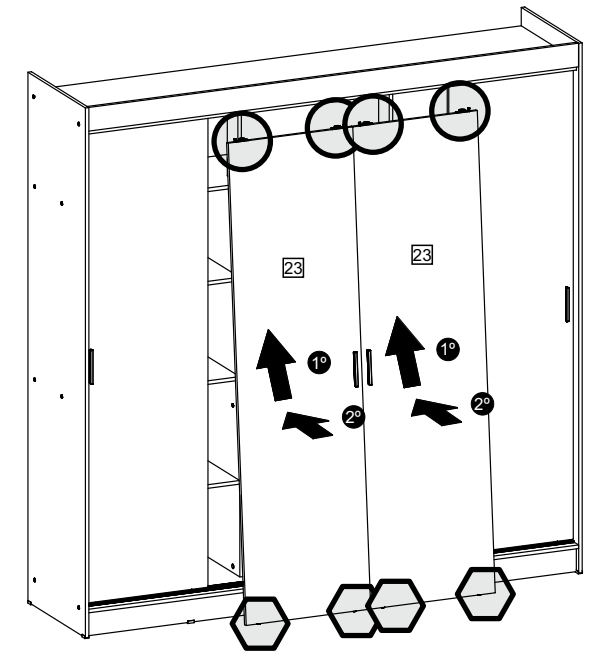
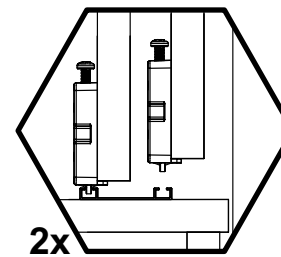
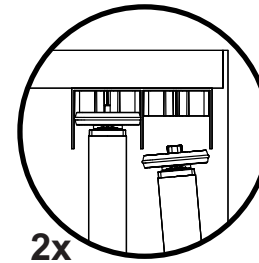

ATENÇÃO - ATENCIÓN - ATTENTION

Destrave as roldanas dos carrinhos depois de instalar as portas.

Desbloquee las poleas del carro después de instalar las puertas

Unlock the cart pulleys after installing the doors

Gire o parafuso para baixo até a roldana destravar
Baje el tornillo hasta que las poleas del carro se desbloqueen
Turn down the screw until the cart pulleys unlocks

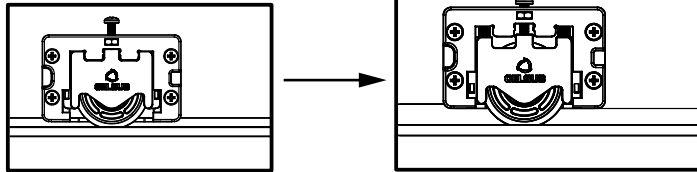

ATENÇÃO - ATENCIÓN - ATTENTION

Ajuste das Portas - Ajuste de las Puertas - Doors Adjustment

