

Capacidade de Carga - Load Capacity - Capacidad de carga

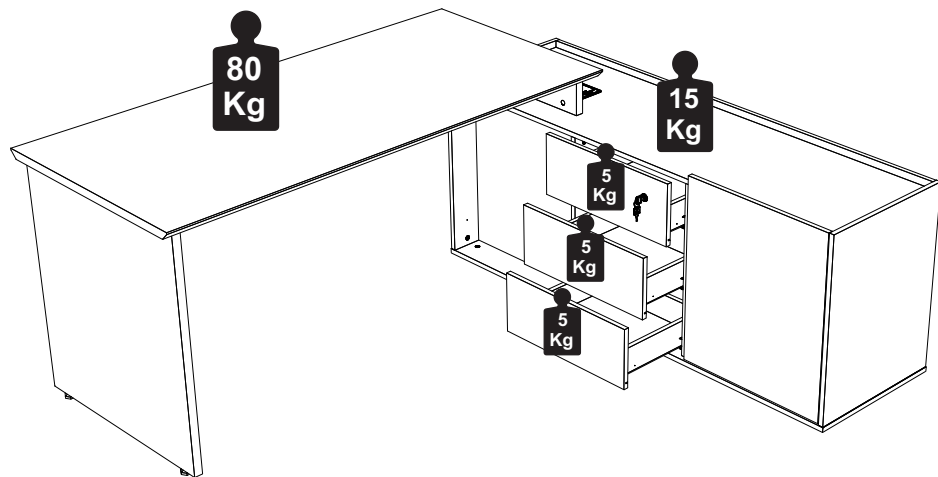

Manutenção e Limpeza

Vidros: pano levemente umedecido com álcool, seguido de pano seco.
Madeiras: pano levemente umedecido com água, seguido de pano seco.
*Nunca utilizar produtos químicos ou abrasivos.

Maintenance and Cleaning

Glasses: cloth lightly moistened with alcohol, followed by dry cloth.
Woods: cloth slightly moistened with water, followed by cloth seo.
*Never use chemicals or abrasives.

Mantenimiento y Limpieza

Vidrios: legeramente humedecido con alcohol, seguido de un paño seco.
Madera: ligeramente humedecido con agua, seguido de un paño seco.
*No utilice nunca productos quimicos o abrasivos.

INSTRUÇÕES DE MONTAGEM ASSEMBLY INSTRUCTIONS INSTRUCCIONES DE MONTAJE

Mesa com Armário Direito

Mesa con gabinete derecho
Table with Right Cabinet

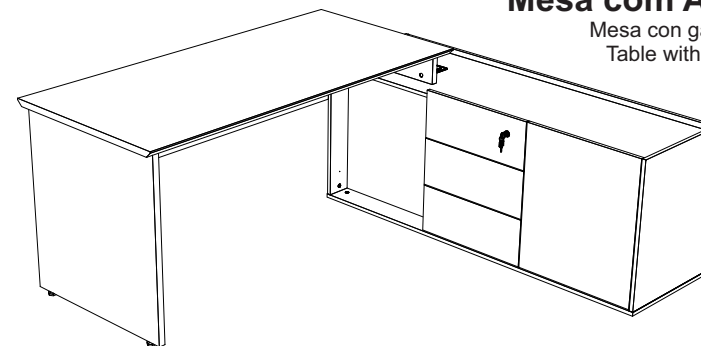

Mesa com Armário Esquerdo

Mesa con gabinete izquierdo
Table with Left Cabinet

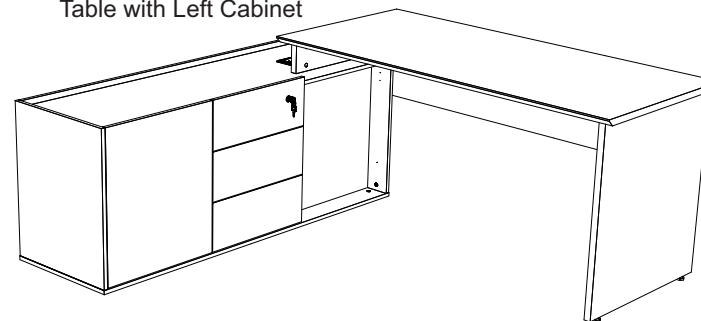

REF. # VRA1818/VRA2018

São necessários:
Son necesarios:
Are necessary:



*Parafusadeira
Atornillador
Screwdriver



*Martelo
Martillo
Hammer



Chave Cruzada
Llave cruzada
Cross wrench

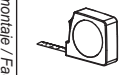

**Trena
Cinta métrica
Measuring tape



90min



2 Pessoas
Persona
Person

*Facilita a montagem / Facilita un montaje / Facilitates mounting.
** Para identificar as peças / Para identificar las partes / To identify the parts.

F5 Office
MÓVEIS CORPORATIVOS

LISTA DE PEÇAS

Parts Identification

Lista de Piezas

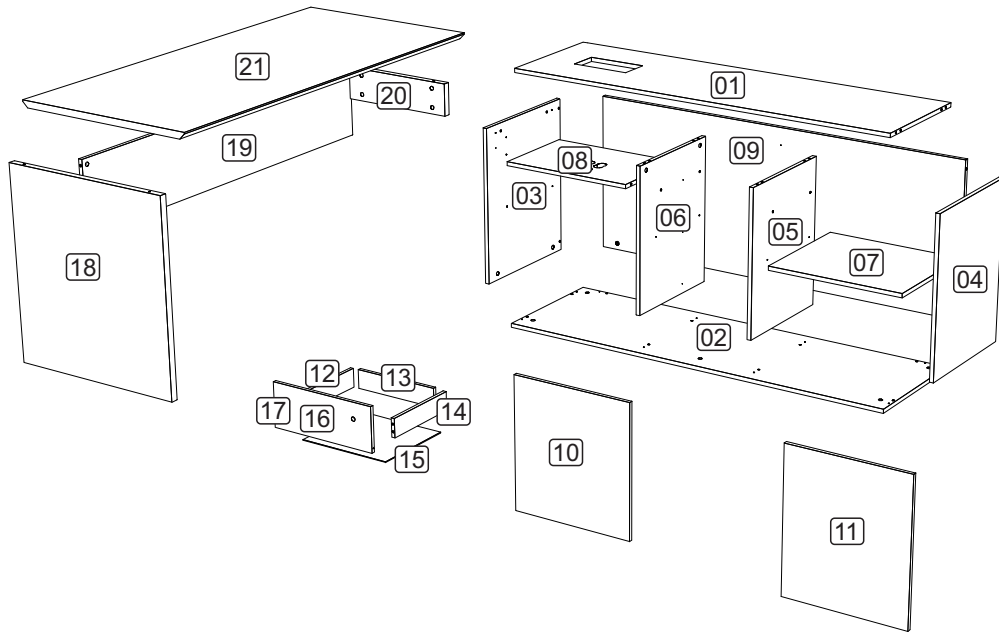

LISTA DE PEÇAS

01 - TAMPO
02 - BASE
03 - LATERAL ESQUERDA
04 - LATERAL DIREITA
05 - DIVISÃO DIREITA
06 - DIVISÃO ESQUERDA
07 - PRATELEIRA
08 - SUPORTE PARA TOMADAS
09 - COSTA
10 - TAMPA
11 - PORTA
12 - LATERAL GAVETA ESQ.
13 - COSTA GAVETA
14 - LATERAL GAVETA DIR.
15 - FUNDO GAVETA
16 - FRENTE GAVETA C/ FECH.
17 - FRENTE GAVETA
18 - PAINEL LATERAL
19 - PAINEL FRONTAL
20 - TRAVESSA
21 - TAMPO MESA

LISTA DE PIEZAS

01 - TABLERO DE MESA
02 - BASE
03 - LATERAL IZQUIERDO
04 - LADO DERECHO
05 - DIVISIÓN DERECHA
06 - DIVISIÓN IZQUIERDA
07 - ESTANTE
08 - SOPORTE DE ENCHUFE
09 - COSTA
10 - TAPA DESMONTABLE
11 - PUERTA
12 - LADO CAJÓN IZQUIERDO.
13 - PARTE TRASERA DEL CAJÓN
14 - LADO DERECHO DEL CAJÓN.
15 - FONDO DE CAJÓN
16 - FRENTE CAJÓN CON CERRADURA
17 - FRENTE CAJÓN
18 - PANEL LATERAL
19 - PANEL FRONTAL
20 - PLACA DE CRUCE
21 - TABLERO DE MESA

PARTS IDENTIFICATION

01 - TOP
02 - BASE
03 - LEFT SIDE
04 - RIGHT SIDE
05 - RIGHT DIVISION
06 - LEFT DIVISION
07 - SHELF
08 - SOCKET SUPPORT
09 - BACK
10 - REMOVABLE LID
11 - DOOR
12 - LEFT DRAWER SIDE
13 - DRAWER BACK
14 - RIGHT DRAWER SIDE
15 - DRAWER BOTTOM
16 - DRAWER FRONT WITH LOCK
17 - DRAWER FRONT
18 - SIDE PANEL
19 - FRONT PANEL
20 - CROSSBOARD
21 - TABLE TOP

Acessórios

Accessories

Accesorios

D1 - CAVILHA 8x30
34x

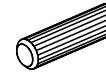

B1 - SUPORTE PRAT.
METÁLICO **6x**



F1 - TAPA FURO Ø18
30x



M6 - CANTONEIRA L
4 FUROS 34x34MM **1x**



A2 - PARAF. 3,5x14 CC
30x



L2 - SAPATA PLAST.
SEXT. **2x**



G7 - DOBRADIÇA 35 C/PISTÃO
SUPER ALTA + CALÇO **2x**



J3 - TRILHO TELESCÓPICO 350MM
3x



A32 - PARAF. MINIFIX
25x

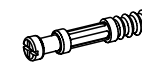

A6 - PARAF. 3,5x40 CC
4x



L4 - DESLIZADOR
P/ARMÁRIO **6x**



I1 - FECHADURA P/GAV.
1x



A3 - PARAF. 3,5x20 CP
24x



L5 - BUCHA PLÁSTICA
P/SAPATA 5/16 **2x**



M1 - CHAPA L 2 FUROS
OBL 42x17x0,9mm ZB **1x**

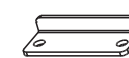

A35 - TAMBOR MINIFIX
31x



A4 - PARAF. 3,5x25 CC
2x



A8 - PARAF. 4,0x14 CP
20x



A36 - BUCHA M6x13
6x



A29 - PARAF. MINIFIX
M6x31m **6x**

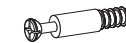

H6 - CANTONEIRA P/GAV
QUICK INSTALL **6x**



T30 - CAIXA DE TOMADA
PLÁSTICA **1x**

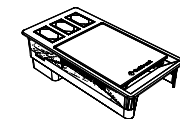

PRÉ-MONTAGEM

Preasamblea

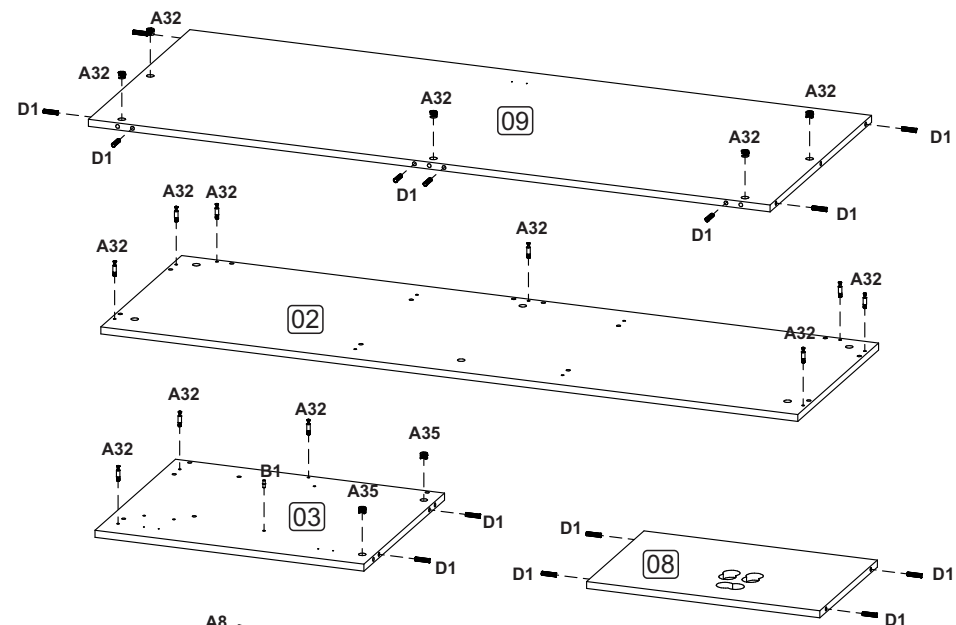
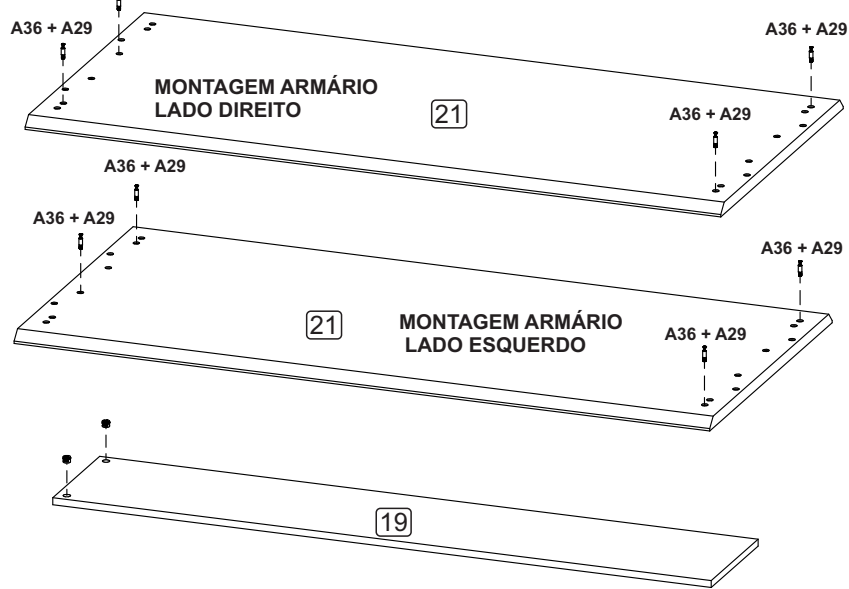



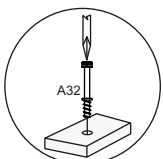
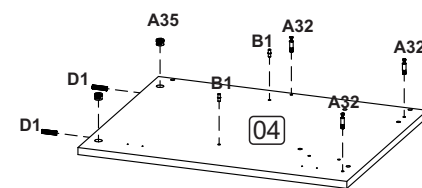
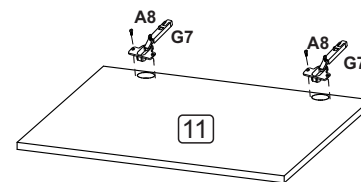
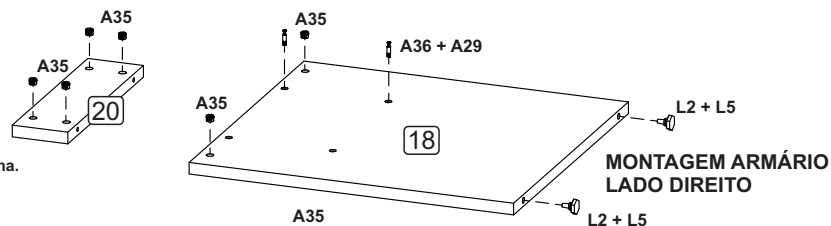



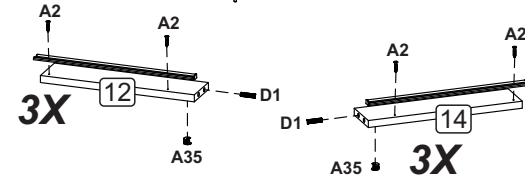
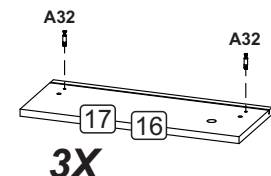
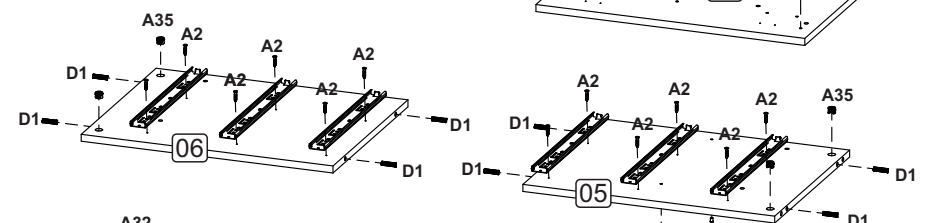
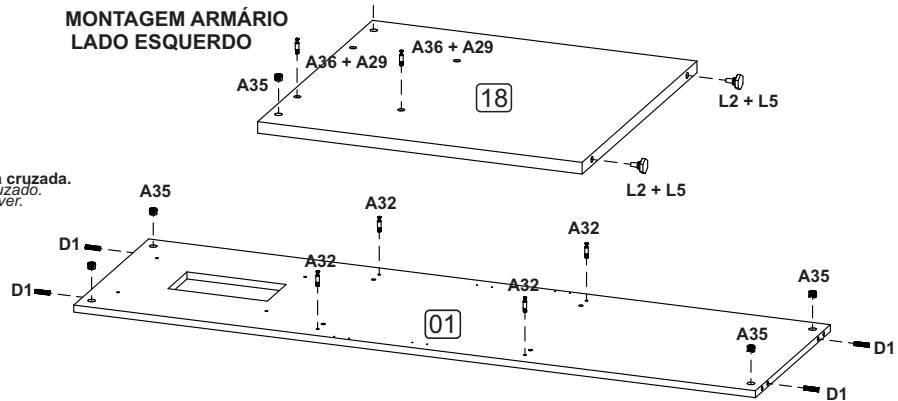

Pressione até o fundo do furo.
 Se necessário utilize um martelo de borracha.
*Presione hasta el fondo del agujero.
 Si es necesario, utilice un mazo de goma.
 Press to the bottom of the hole.
 If necessary use a rubber mallet.*



Parafuse com uma chave de fenda cruzada.
 Atornille con un destornillador cruzado.
Screw with a crossed screwdriver.



- 
L2 - 2x
- 
L5 - 2x
- 
B1 - 06x
- 
A35 - 31x
- 
A32 - 23x
- 
D1 - 34x
- 
A36 - 6x
- 
A29 - 6x
- 
J3 - 3x
- 
A2 - 30x
- 
G7 - 2x
- 
A8 - 20x

1 MONTAGEM
Armado
Assembly

MONTAGEM ARMÁRIO LADO DIREITO

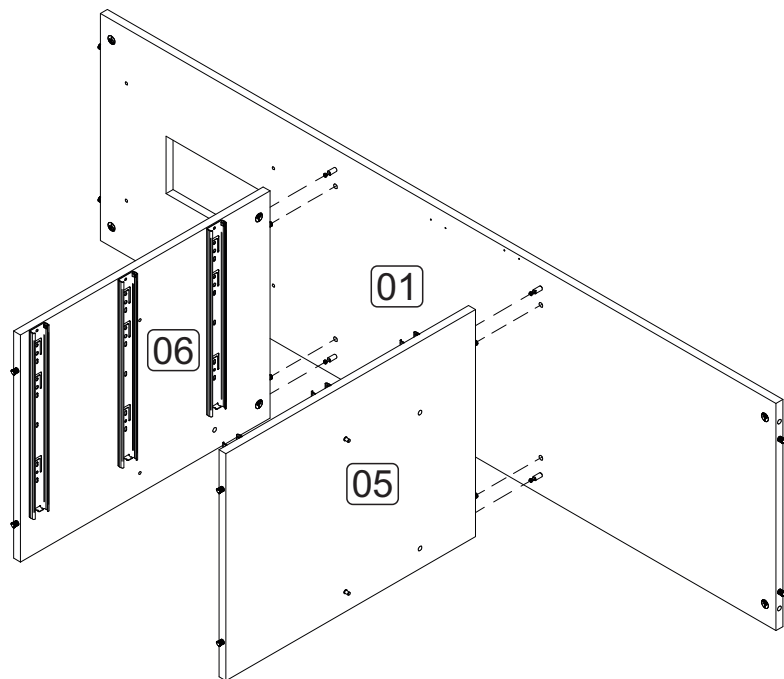

Detalle / Detail
DETALHE 1

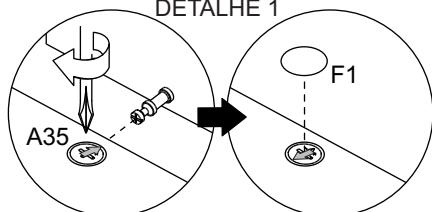

Depois de encaixar as peças coloque o tambor com a sua seta voltada para o parafuso. Para apertar Gire no sentido horário.
Después de colocar las piezas, coloque el tambor con su flecha hacia el tornillo. Para apretar, gire en sentido horario.
After fitting the parts, place the drum with its arrow facing the screw. To tighten, turn clockwise.

1 MONTAGEM
Armado
Assembly

MONTAGEM ARMÁRIO LADO ESQUERDO

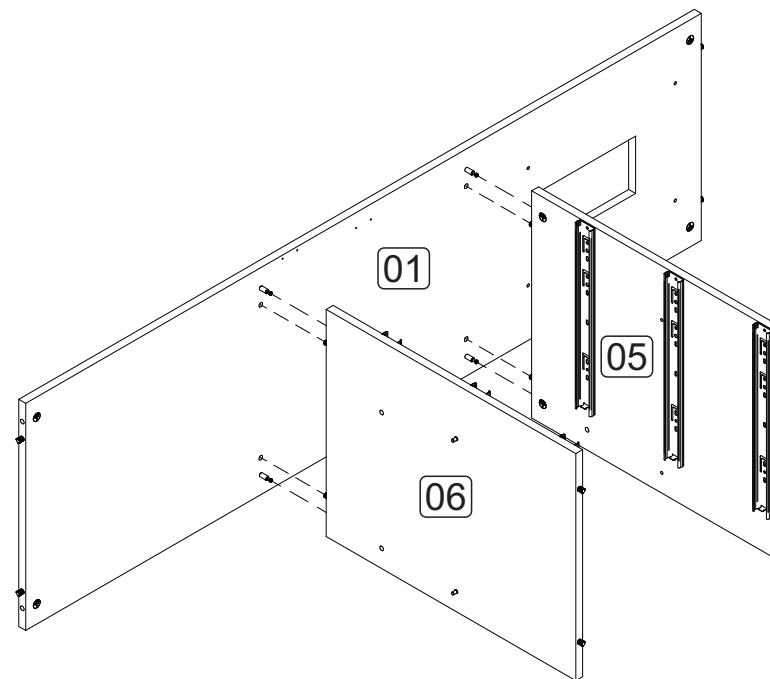

Detalle / Detail
DETALHE 1

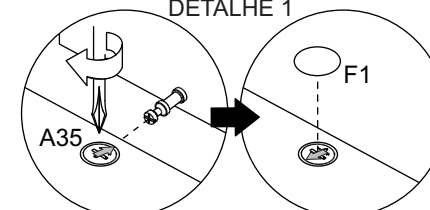

Depois de encaixar as peças coloque o tambor com a sua seta voltada para o parafuso. Para apertar Gire no sentido horário.
Después de colocar las piezas, coloque el tambor con su flecha hacia el tornillo. Para apretar, gire en sentido horario.
After fitting the parts, place the drum with its arrow facing the screw. To tighten, turn clockwise.

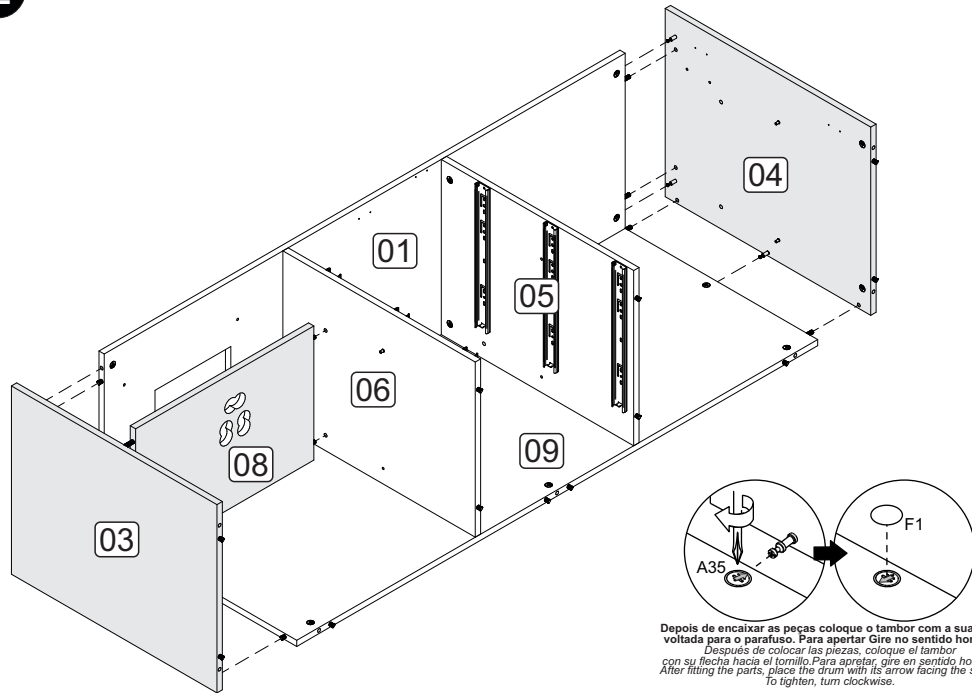
2**MONTAGEM ARMÁRIO LADO DIREITO**

Depois de encaixar as peças coloque o tambor com a sua seta voltada para o parafuso. Para apertar Gire no sentido horário.
 Después de colocar las piezas, coloque el tambor con su flecha hacia el tornillo. Para apretar, gire en sentido horario.
 After fitting the parts, place the drum with its arrow facing the screw. To tighten, turn clockwise.

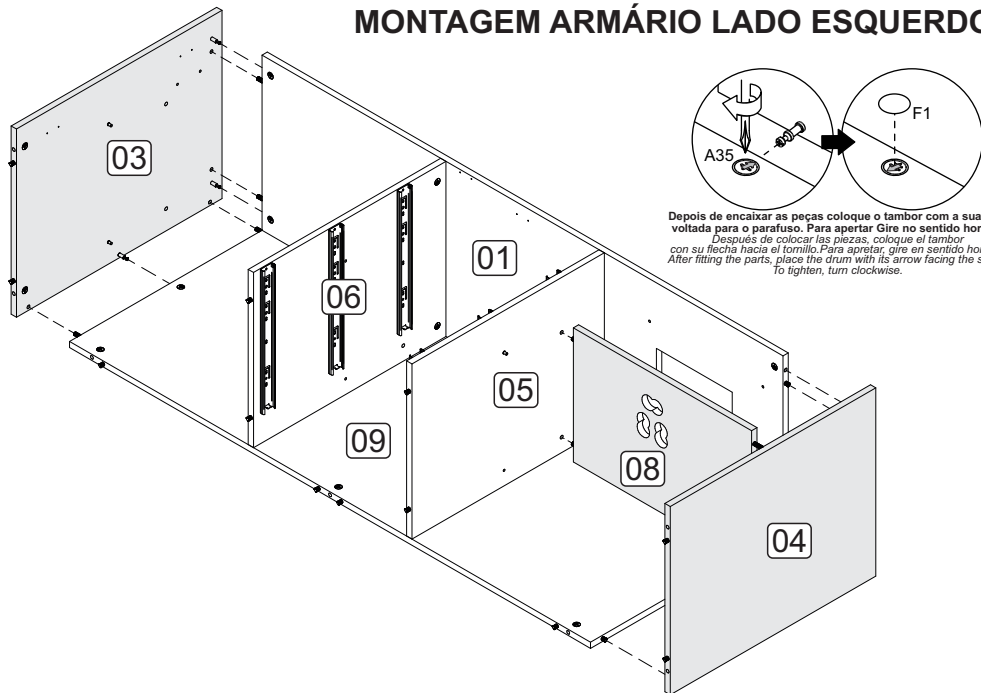
MONTAGEM ARMÁRIO LADO ESQUERDO

Depois de encaixar as peças coloque o tambor com a sua seta voltada para o parafuso. Para apertar Gire no sentido horário.
 Después de colocar las piezas, coloque el tambor con su flecha hacia el tornillo. Para apretar, gire en sentido horario.
 After fitting the parts, place the drum with its arrow facing the screw. To tighten, turn clockwise.

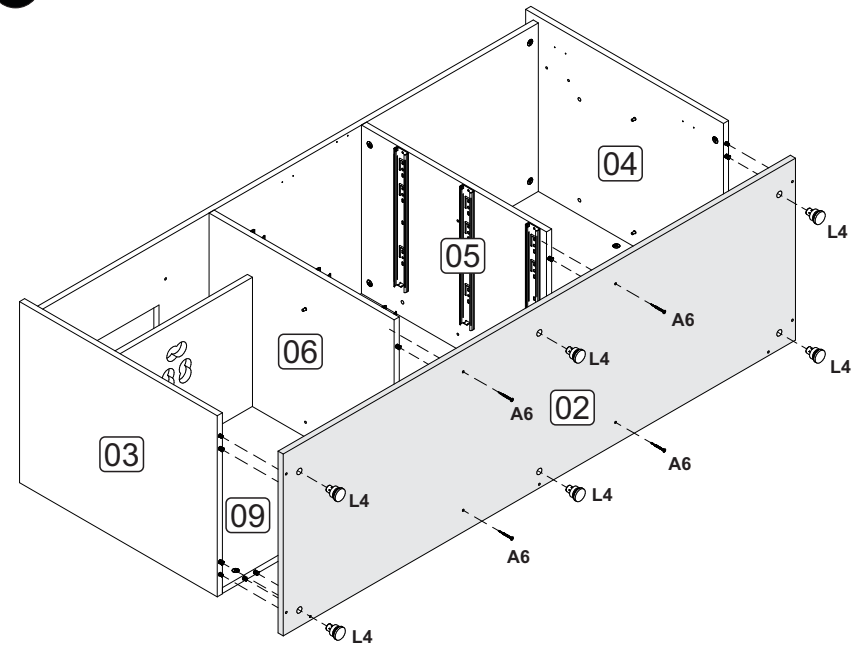
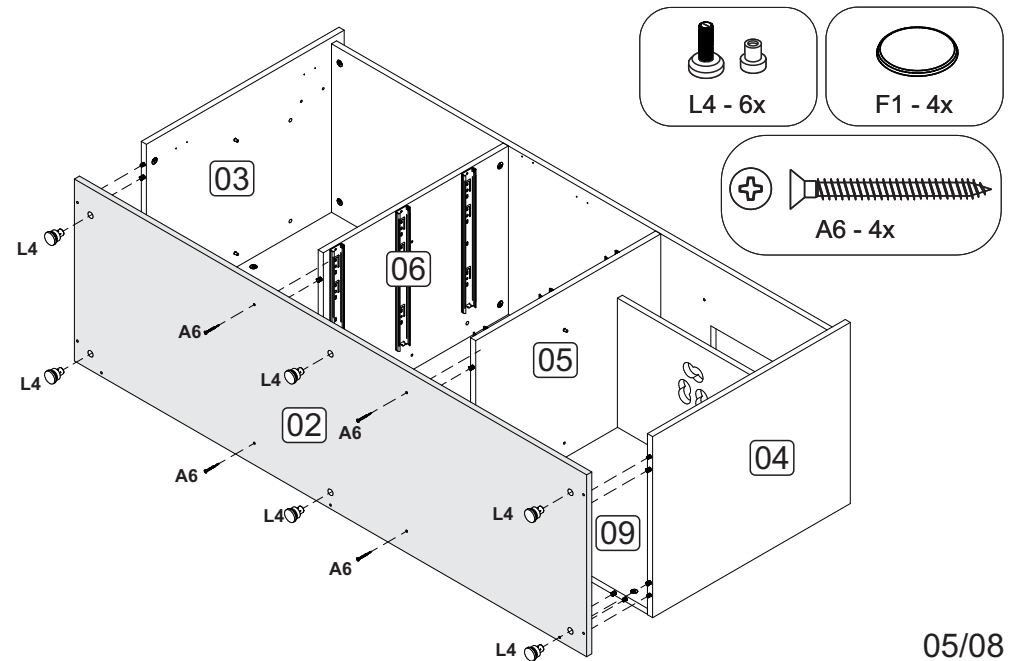
3**MONTAGEM ARMÁRIO LADO DIREITO****MONTAGEM ARMÁRIO LADO ESQUERDO**

4

MONTAGEM ARMÁRIO LADO DIREITO

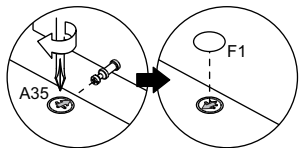

Depois de encaixar as peças coloque o tambor com a sua seta voltada para o parafuso. Para apertar Gire no sentido horário.
 Después de colocar las piezas, coloque el tambor con su flecha hacia el tornillo. Para apretar, gire en sentido horario.
 After fitting the parts, place the drum with its arrow facing the screw. To tighten, turn clockwise.

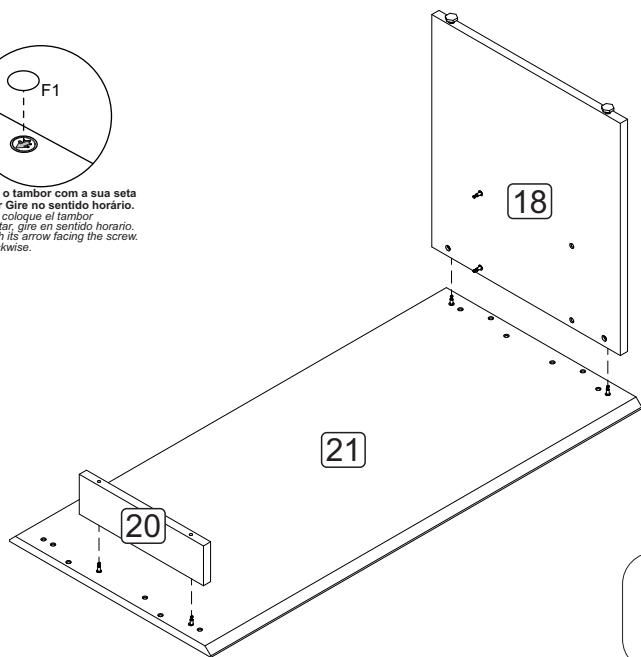

F1 - 4x

MONTAGEM ARMÁRIO LADO ESQUERDO

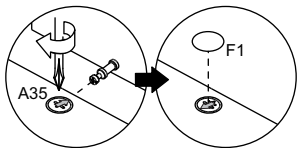

Depois de encaixar as peças coloque o tambor com a sua seta voltada para o parafuso. Para apertar Gire no sentido horário.
 Después de colocar las piezas, coloque el tambor con su flecha hacia el tornillo. Para apretar, gire en sentido horario.
 After fitting the parts, place the drum with its arrow facing the screw. To tighten, turn clockwise.

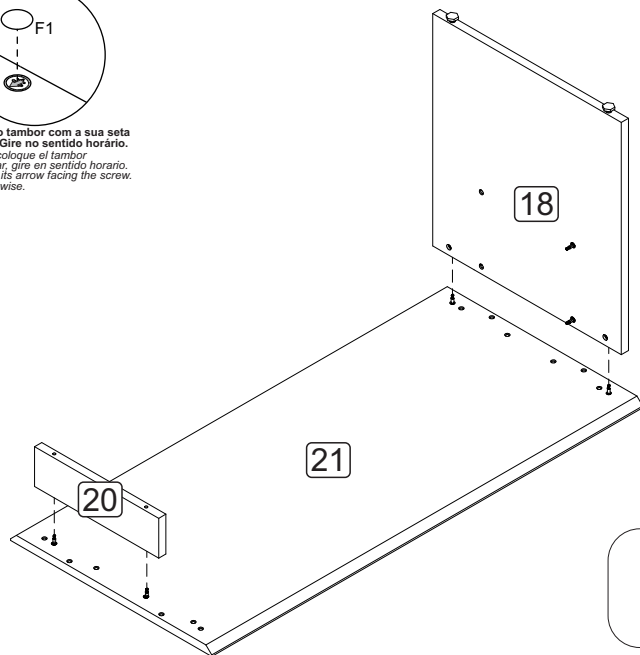

F1 - 4x

5

MONTAGEM ARMÁRIO LADO DIREITO

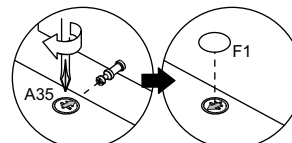

Depois de encaixar as peças coloque o tambor com a sua seta voltada para o parafuso. Para apertar Gire no sentido horário.
 Después de colocar las piezas, coloque el tambor con su flecha hacia el tornillo. Para apretar, gire en sentido horario.
 After fitting the parts, place the drum with its arrow facing the screw. To tighten, turn clockwise.



F1 - 2x

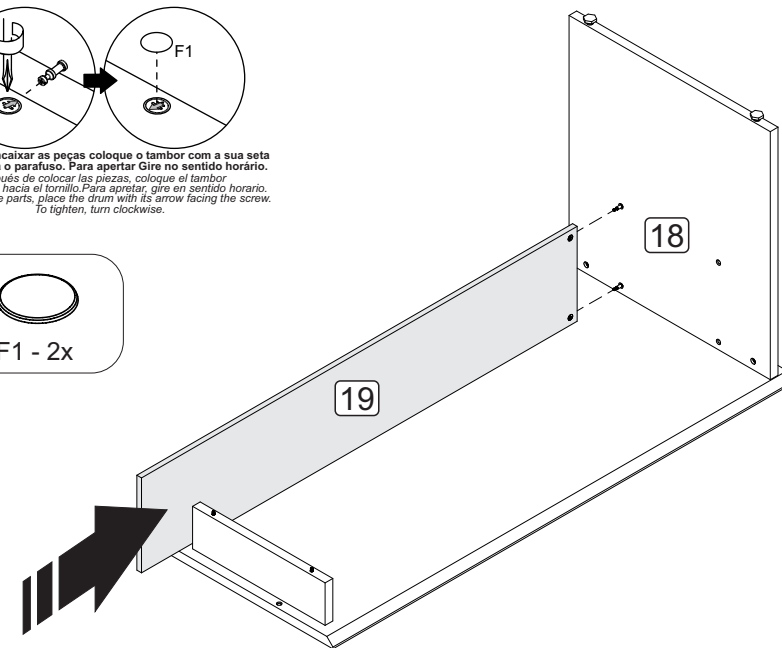

MONTAGEM ARMÁRIO LADO ESQUERDO

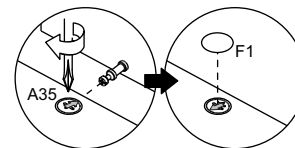

Depois de encaixar as peças coloque o tambor com a sua seta voltada para o parafuso. Para apertar Gire no sentido horário.
 Después de colocar las piezas, coloque el tambor con su flecha hacia el tornillo. Para apretar, gire en sentido horario.
 After fitting the parts, place the drum with its arrow facing the screw. To tighten, turn clockwise.



F1 - 2x

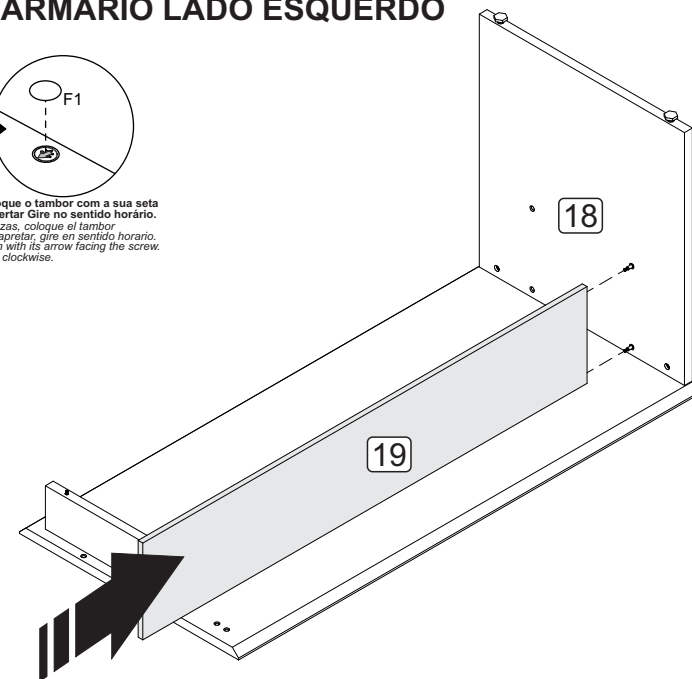

6

MONTAGEM ARMÁRIO LADO DIREITO

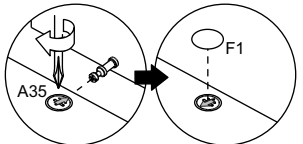

Depois de encaixar as peças coloque o tambor com a sua seta voltada para o parafuso. Para apertar Gire no sentido horário.
Después de colocar las piezas, coloque el tambor con su flecha hacia el tornillo. Para apretar, gire en sentido horario. After fitting the parts, place the drum with its arrow facing the screw. To tighten, turn clockwise.

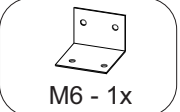
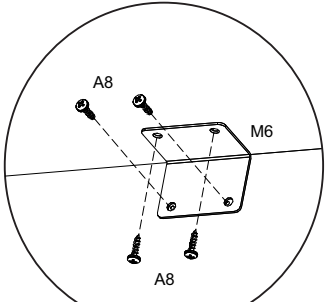

M6 - 1x

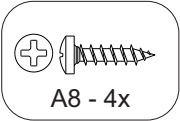

A8 - 4x

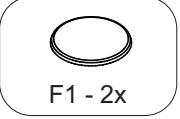

F1 - 2x

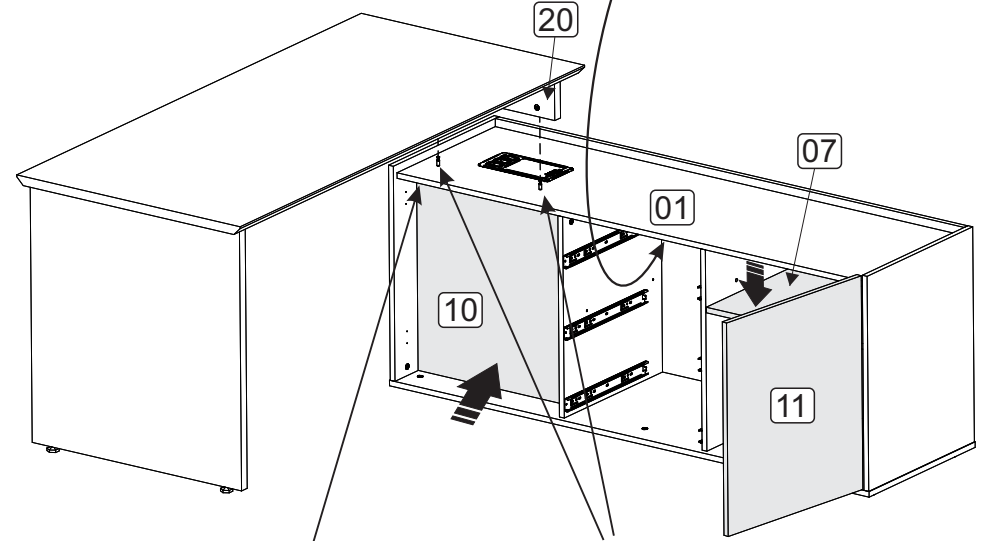

Furar o tampo do armário com uma broca de 5mm

MONTAGEM ARMÁRIO LADO ESQUERDO

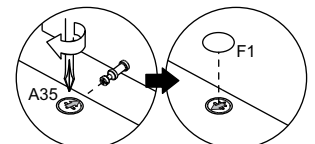

Depois de encaixar as peças coloque o tambor com a sua seta voltada para o parafuso. Para apertar Gire no sentido horário.
Después de colocar las piezas, coloque el tambor con su flecha hacia el tornillo. Para apretar, gire en sentido horario. After fitting the parts, place the drum with its arrow facing the screw. To tighten, turn clockwise.

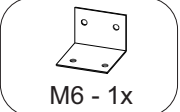
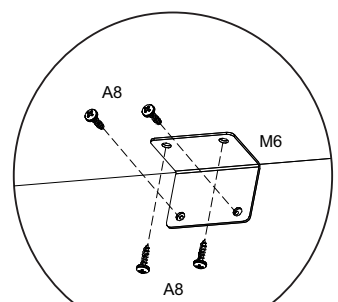

M6 - 1x

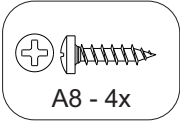

A8 - 4x

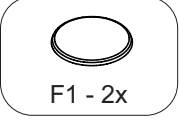

F1 - 2x

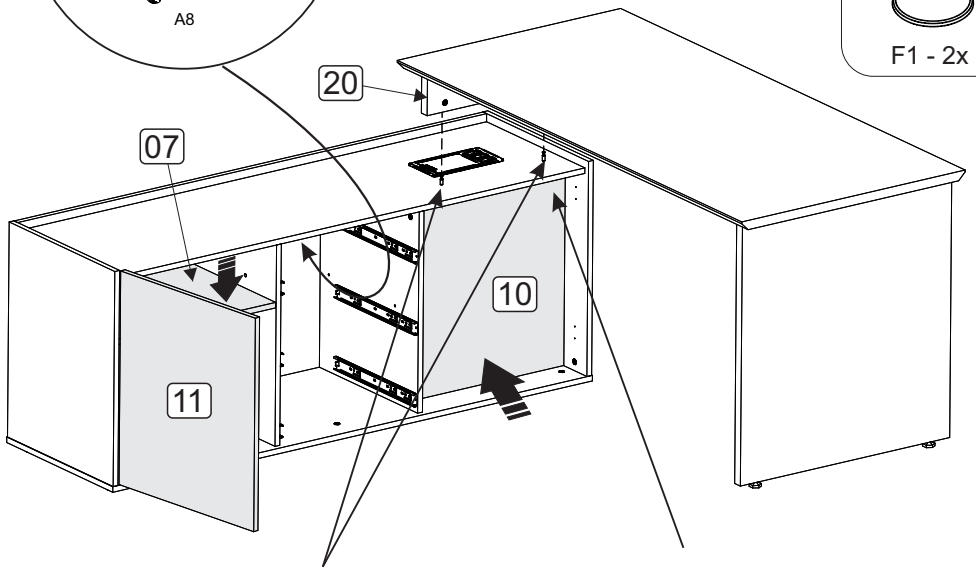

Furar o tampo do armário com uma broca de 5mm

Fixação do painel frontal

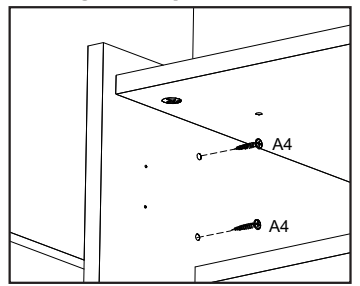

Fixação do painel frontal

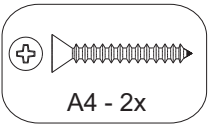
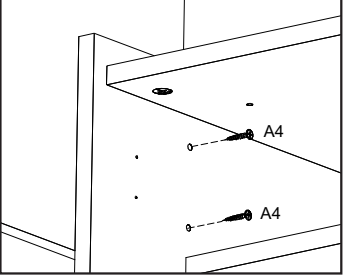

A4 - 2x

REGULAGEM DA PORTA

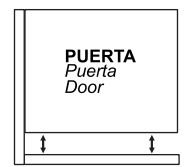

AJUSTE DE ALTURA
Ajuste de altura
Height adjustment

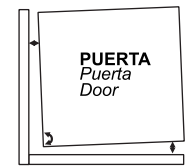
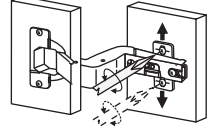

AJUSTE INTERNO
Ajuste interno
Internal adjustment

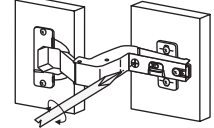

AJUSTE DE PROFUNDIDADE
Ajuste de profundidade
Depth adjustment

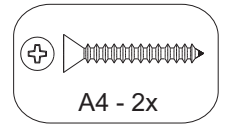
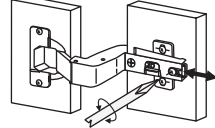

A4 - 2x

7

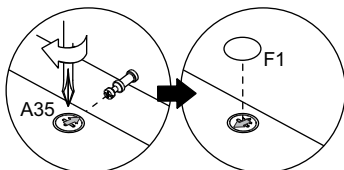
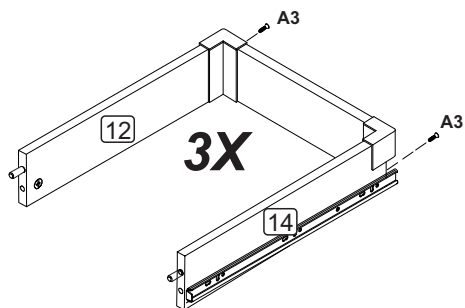
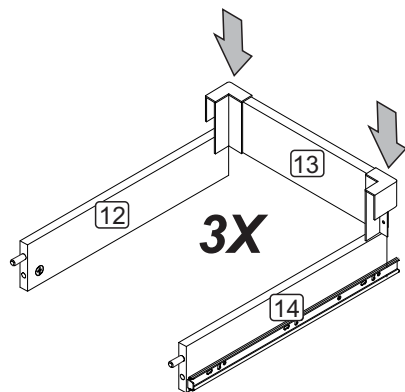
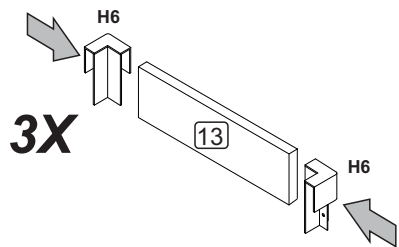

Depois de encaixar as peças coloque o tambor com a sua seta voltada para o parafuso. Para apertar Gire no sentido horário.
 Después de colocar las piezas, coloque el tambor con su flecha hacia el tornillo. Para apretar, gire en sentido horario.
 After fitting the parts, place the drum with its arrow facing the screw. To tighten, turn clockwise.

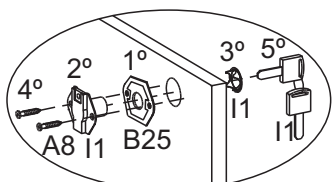
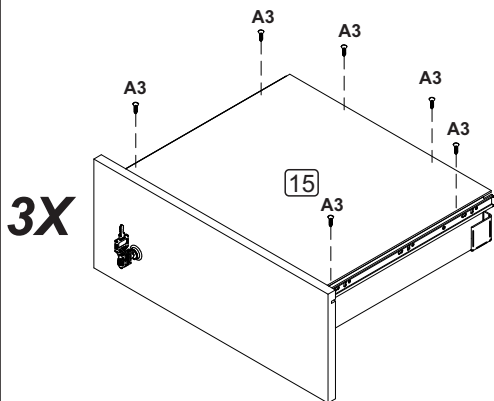
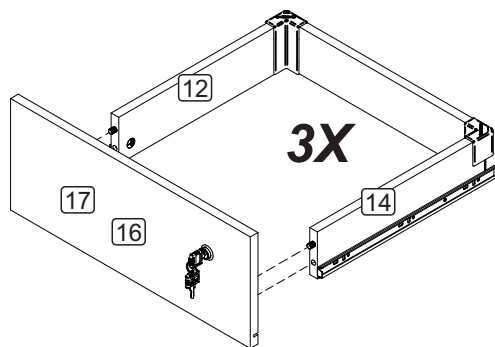

Siga a ordem crescente de instalação.
 Siga el orden ascendente de instalación
 Follow the ascending order of installation



B25 - 1x



I1 - 1x



F1 - 2x



F1 - 6x



H6 - 6x



A3 - 24x

8

MONTAGEM ARMÁRIO LADO DIREITO

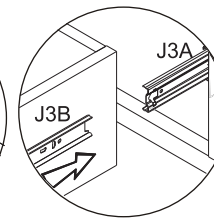
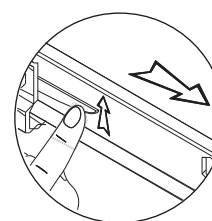
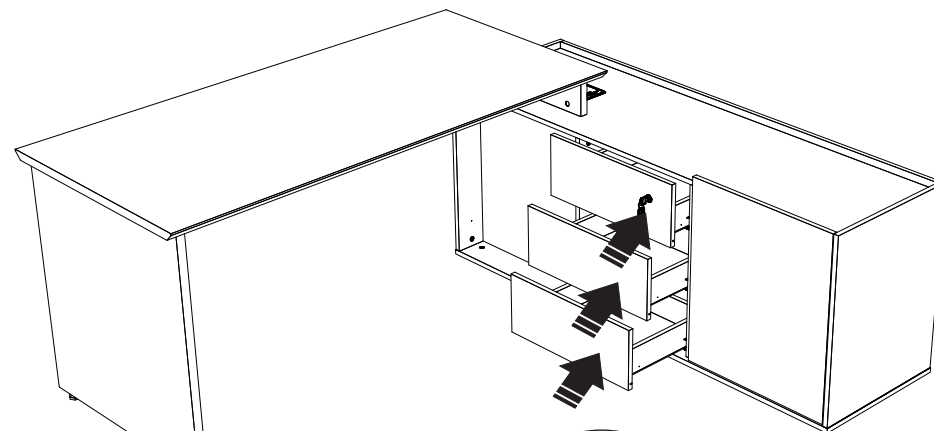

MONTAGEM ARMÁRIO LADO ESQUERDO

