

RP2630 ROUPEIRO

Manual de Montagem
 Assembly Instructions
 Instrucción de Montaje

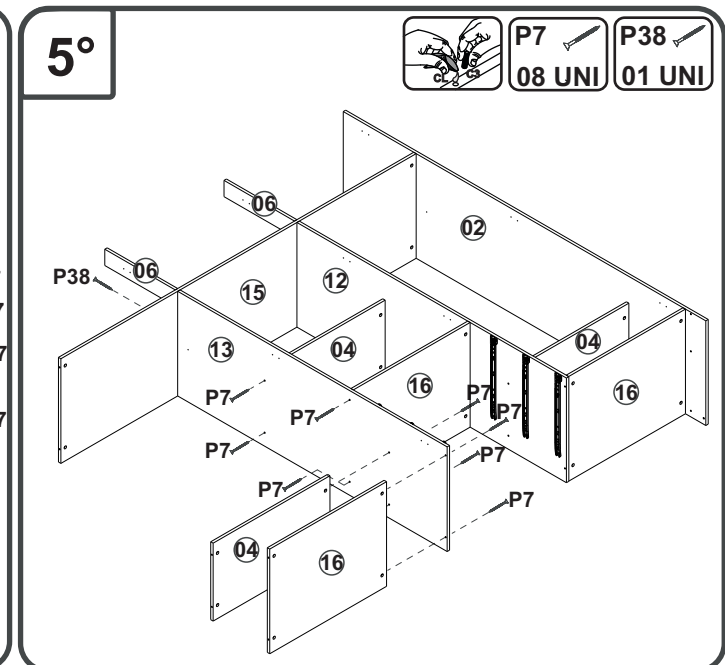
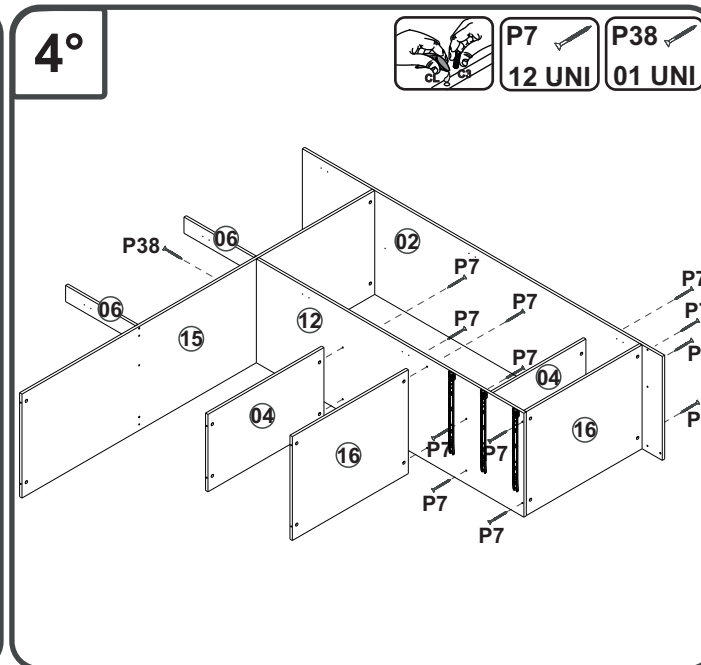
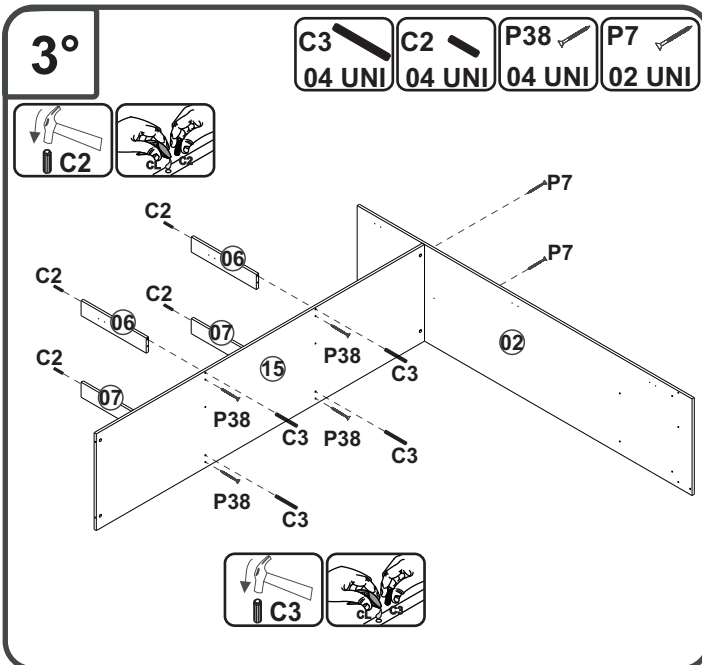
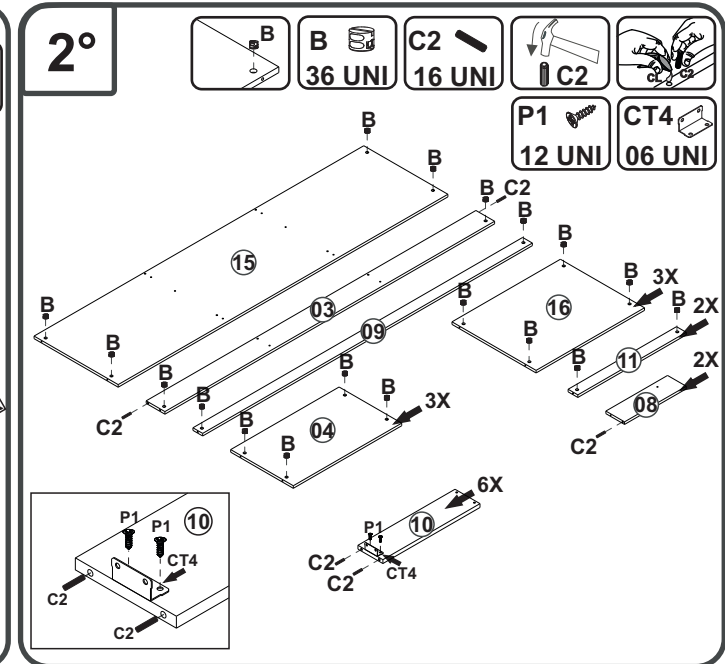
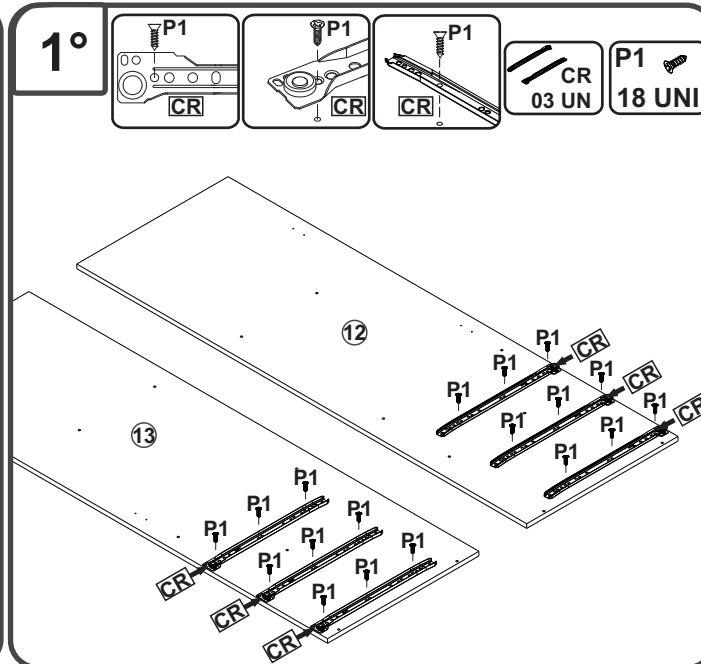
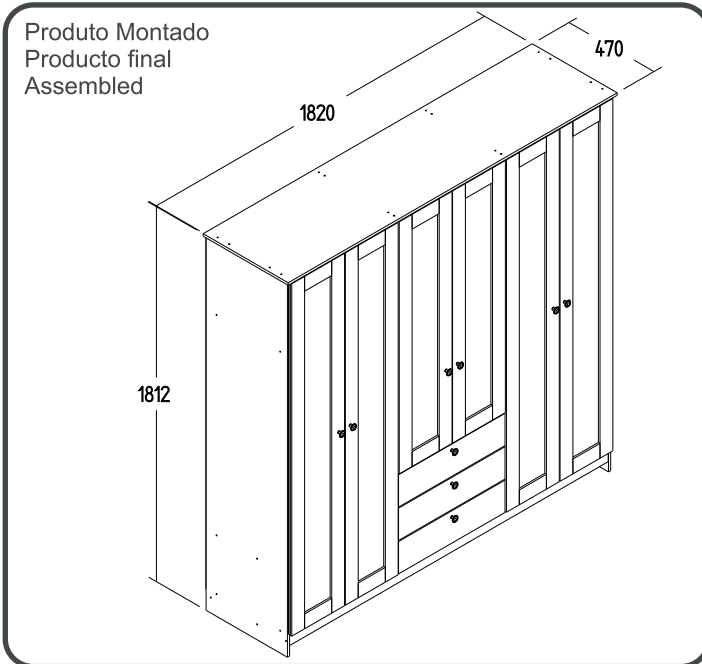

11°

- Pr1
- Pr1
132 UNI
- FX
28 UNI

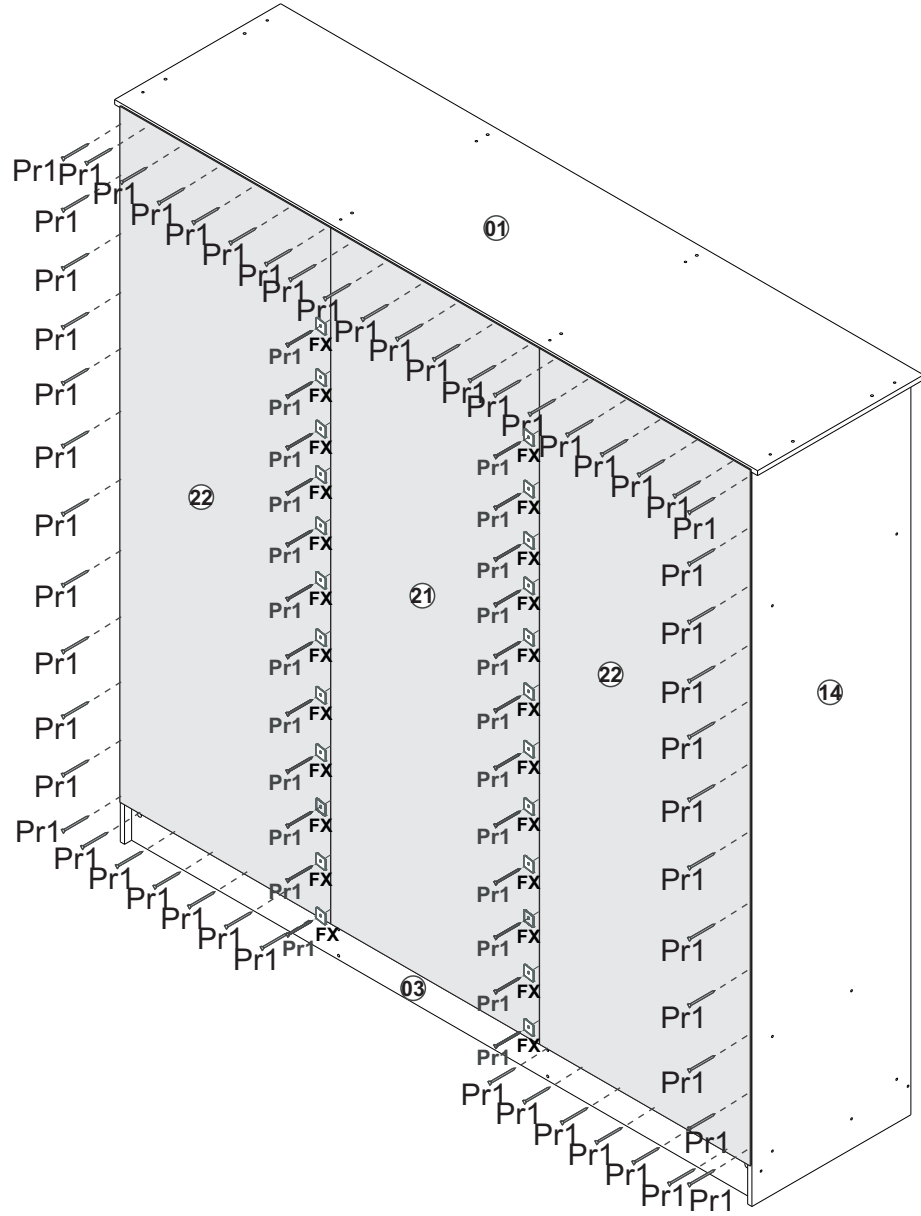

12°

3X

- PX
01 UNI
- P16
01 UNI
- P38
04 UNI
- PR1
10 UNI
- P1
10 UNI

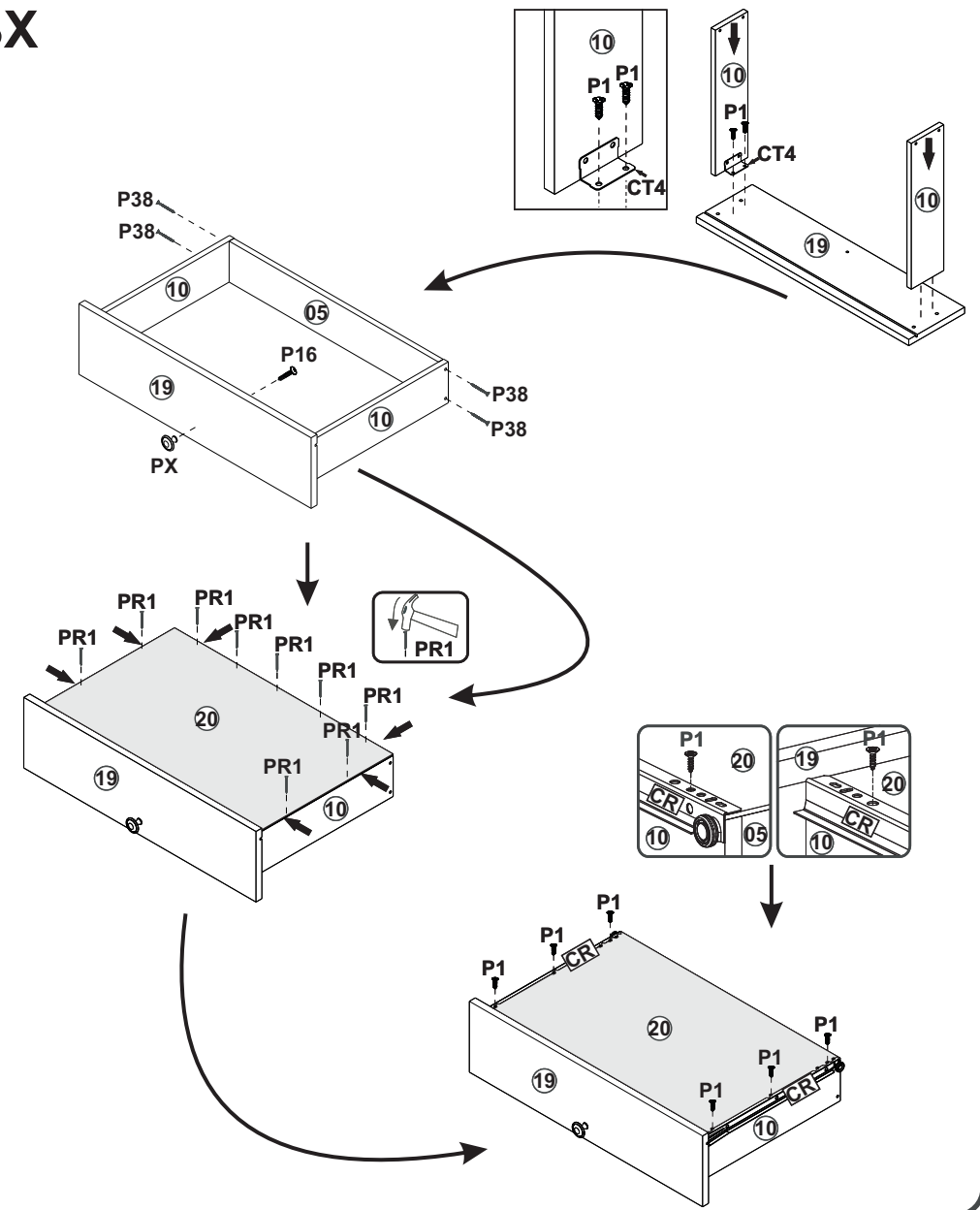

RP2630 ROUPEIRO

Manual de Montagem
 Assembly Instructions
 Instrucción de Montaje

decibal[®] móveis

13°



PESO SUPORTADO DISTRIBUÍDO.
 PESO SOPORTADO DISTRIBUIDO.
 DISTRIBUTED SUPPORTED WEIGHT.

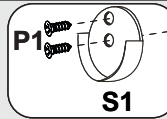
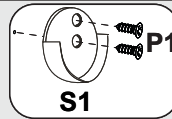

S1
 04 UNI

P1
 08 UNI

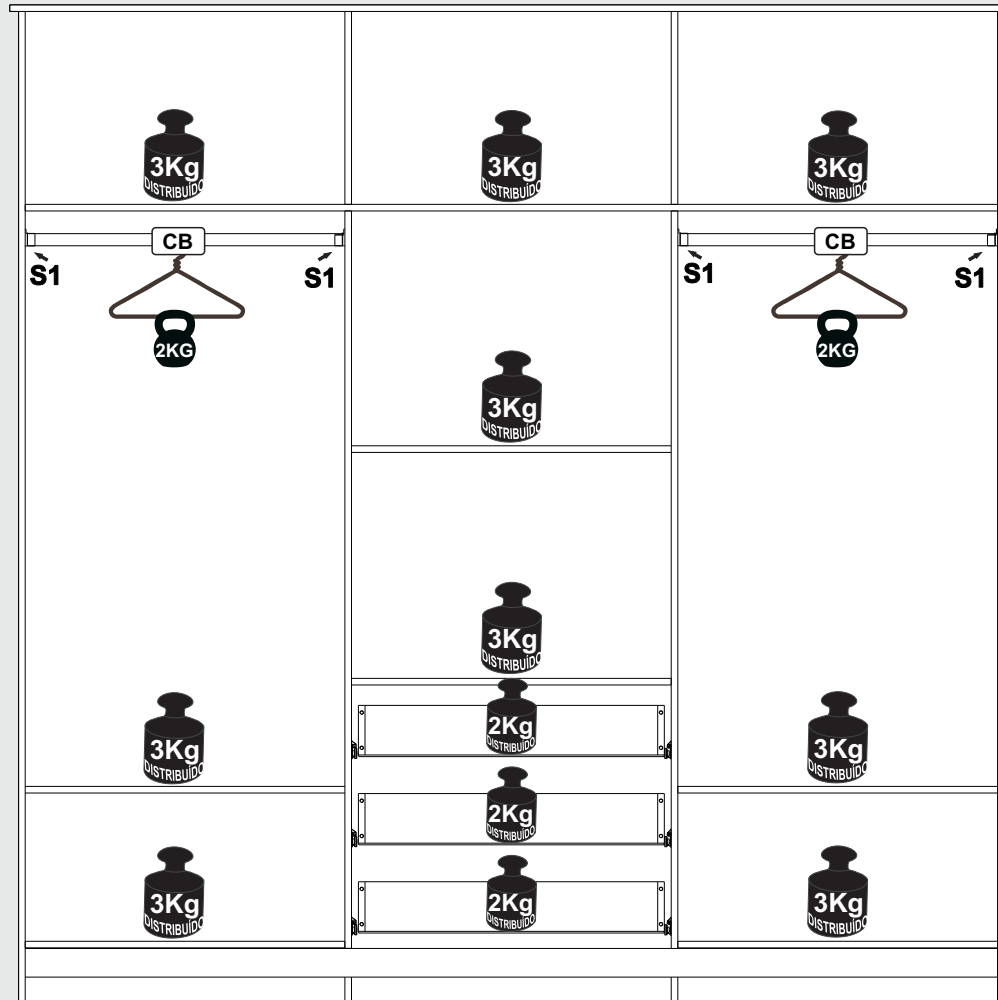

14°

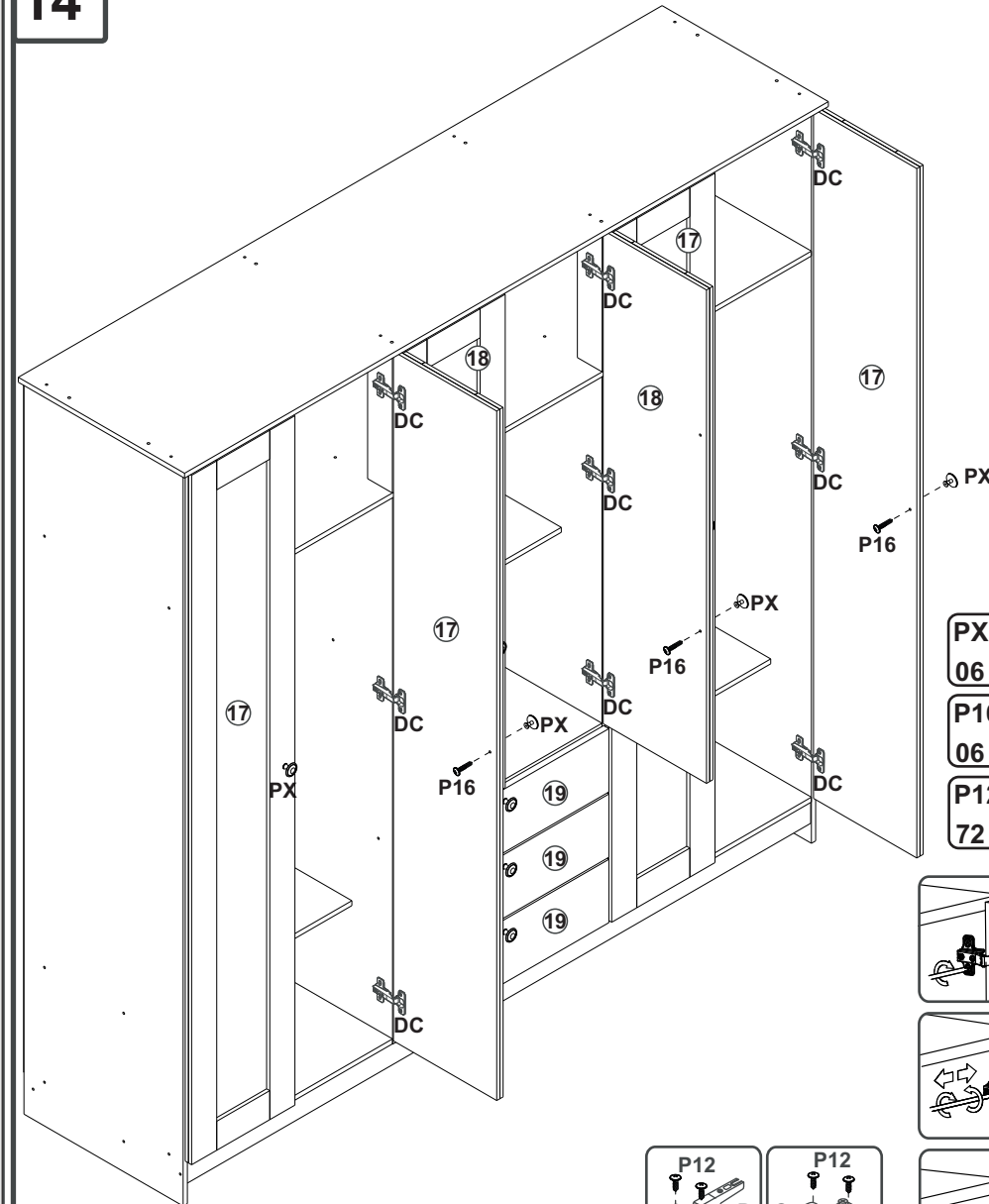

PX
 06 UNI

P16
 06 UNI

P12
 72 UNI

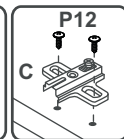
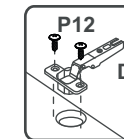
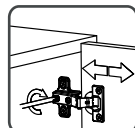
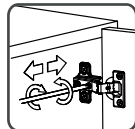
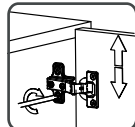

RP2630 ROUPEIRO

Manual de Montagem
Assembly Instructions
Instrucción de Montaje



decibal[®]
móveis

Instrucción de Montaje

Relação de Peças/ Relación de Piezas/Parts List

Nº	CÓDIGO/CODE	DESCRIÇÃO/DESCRIPCIÓN/DESCRIPTION	QTD/CANT	VOL.
1	0570494	TAMPO/TAPA/TOP	1820X470X12MM	1 1
2	0570486	LATERAL DIR/LATERAL/SIDE	1800X450X12MM	1 1
3	0570493	RODAPE TRS/ZÓCALO/BASEBOARD	1764X100X12MM	1 1
4	0570892	PRATELEIRA/ESTANTE/SHELF	580X335X12MM	3 1/2
5	0570481	BATENTE/REVÊS CAJÓN/DRAWER BACK	531x90X12MM	3 1
6	0570896	PILASTRA SUP/PILASTRE/PILASTER	350X70X12MM	2 1
7	0570897	PILASTRA SUP T/PILASTRE/PILASTER	350X70X12MM	2 1
8	0570492	RODAPE INT/ZÓCALO/BASEBOARD	330X100X12 MM	2 1
9	0570491	RODAPE FRT/ZÓCALO/BASEBOARD	1764X52X12MM	1 1
10	0570524	LAT GAV/LATERAL CAJÓN/DRAWER SIDE	531X90X12MM	6 1
11	0570898	TRAVESSA RP/TRAVIESSA/TRVERSE	350X90X12 MM	2 1
12	0570890	DIVISORIA DIR/DIVISOR DERECHO/RIGTH DIVIDER	1338X450X12MM	1 1
13	0570531	DIVISORIA ESQ/DIVISOR ESQUIERDO/LEFT DIVIDER	1338X450X12MM	1 1
14	0570487	LATERAL ESQ/LATERAL/SIDE	1800X450X12MM	1 1
15	0570893	BASE MALEIRO/BASE MALETA/SUITCASO BASE	1764X450X12MM	1 1
16	0570889	BASE	580X450X12MM	3 2
17	0571170	PORTA MAIOR/PUERTA/DOOR	1688X292X18MM	4 2
18	0571163	PORTA MENOR/PUERTA/DOOR	1208X292X18MM	2 2
19	0570484	FRENTE GAV/FRENTE CAJÓN/	589X155X15MM	3 2
20	0570504	FUNDO GAV/FONDO CAJÓN/DRAWER BOTTOM	554X355X2,8MM	3 2
21	0570501	COSTA CENTRAL/REVÊS/BACK	1706X590X2,8MM	1 2
22	0570500	COSTA/REVÊS/BACK	1706X596X2,8MM	2 2

Escala (N/A)

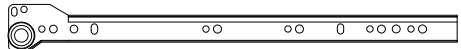
LEGENDA	DESCRIÇÃO/DESCRIPCIÓN/DESCRIPTION	CÓDIGO	QUANT.
CB	 CABIDEIRO/ROLIZO PERCHA/ROD FOR HANGERS 570 MM	13490	02
PX	 PUXADOR/PEGADOR/HANDLE	13039	09
CR	 CORREDICA/CORREDERA/METTALIC SLIDE 350MM	01225	03

www.decibal.com.br



120 min.



2 montador
2 ajustador
2 fitter

Ferramentas necessárias
Necessary tools
Herramientas necesarias

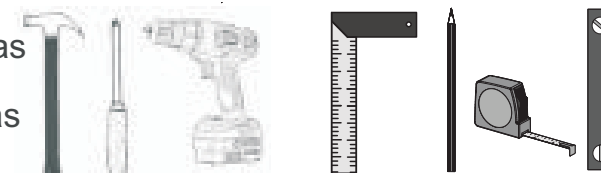

ATENÇÃO!!!! montadores e consumidores

* Para limpar o móvel utilize somente um pano úmido (umedecido em água pura ou água com sabão neutro). Depois, passe um pano seco. Evite a umidade excessiva.

* Evite usar álcool, água sanitária, detergente e outros produtos químicos, mesmo diluídos em água.

* Não utilize produtos abrasivos de nenhuma espécie

ATENCIÓN!!!! montadores e consumidores

* Para limpiar el mueble utilice solamente un paño húmedo (humedecido con agua limpia o con un jabón suave). A continuación, utilice un paño seco. Evite el exceso de humedad.

* Evite uso de alcohol, hipoclorido solución basada, detergente y otros productos químicos, mismo diluídos en agua. No utilice productos abrasivos de ningún tipo.

ATTENTION!!!! assemblers and consumers

* To clean the furniture, use only a damp cloth (humidify it only in pure water ou water and neutral soap). After, use a dry cloth. Avoid excessive humidity.

* Avoid using alcohol, bleach, detergent and other chemical products, even diluted in water. Do not use any kind of abrasive cleaning agents to clean the furniture.

The use of such products may jeopardize the ?nal characteristics of the furniture.

ATENÇÃO!!!! montadores e consumidores

* Ajustar o torque da parafusadeira para não danificar as peças escareando o parafuso *

ATENCIÓN!!!! montadores e consumidores

* Ajuste el torque del destornillador para no dañar las piezas avallanando el tornillo *















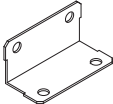

ATTENTION!!!! assemblers and consumers

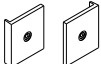
* Adjust the torque of the screwdriver so as not to damage the parts by countersinking the screw *

RP2630 ROUPEIRO

Manual de Montagem
Assembly Instructions
Instrucción de Montaje

decibal[®]
móveis

Escala (1:1)				Escala (N/A)			
LEGENDA	DESCRIÇÃO/DESCRIPCIÓN/DESCRIPTION	CÓDIGO	QUANT.	LEGENDA	DESCRIÇÃO/DESCRIPCIÓN/DESCRIPTION	CÓDIGO	QUANT.
P1	 PARAFUSO/TORNILLO/SCREW 3X12	01328	68	CL	 COLA/PEGAMENTO/GLUE	01213	01
P7	 PARAFUSO/TORNILLO/SCREW 4X45	01318	36	ET	 ETIQUETA LOGO DECIBAL/LABEL DECIBAL	01312	01
P12	 PARAFUSO/TORNILLO/SCREW 3,5X13	09927	108	Ct4	 CANTONEIRA/PIEZA L/SHEET	03110	06
P16	 PARAFUSO/TORNILLO/SCREW 3,5X30	13502	09	Ct1	 CANTONEIRA/PIEZA L/SHEET	03077	18
P38	 PARAFUSO/TORNILLO/SCREW 3,5X40	12425	28	PE	PE/PATA/FOOT 15X15MM 	01367	08
PR1	 PREGO/CLAVO/NAIL 10X10	01330	170	S1	 SUPORTE CABIDEIRO/SOPORTE PERCHERO SUPPORT TO HANGER SUPPORT	02033	04
B	BUCJA/BUJE/BUCHING 	02734	36	FX	 FIXADOR COSTA/FIJADOR FONDO/FIXER COAST	01331	28
C2	 CAVILHA/TARUGO/DOWEL 6X30 MM	01211	26	AD	 ADESIVO/ADHESIVO/ADHESIVE	15mm	18
C3	 CAVILHA/TARUGO/DOWEL 6X50 MM	01212	04	DC	 DOBRADIÇA/BISAGRA/HINGE D=26mm C=5mm	12656	18



CM4300 - CÔMODA

Manual de Montagem
 Assembly Instructions
 Instrucción de Montaje

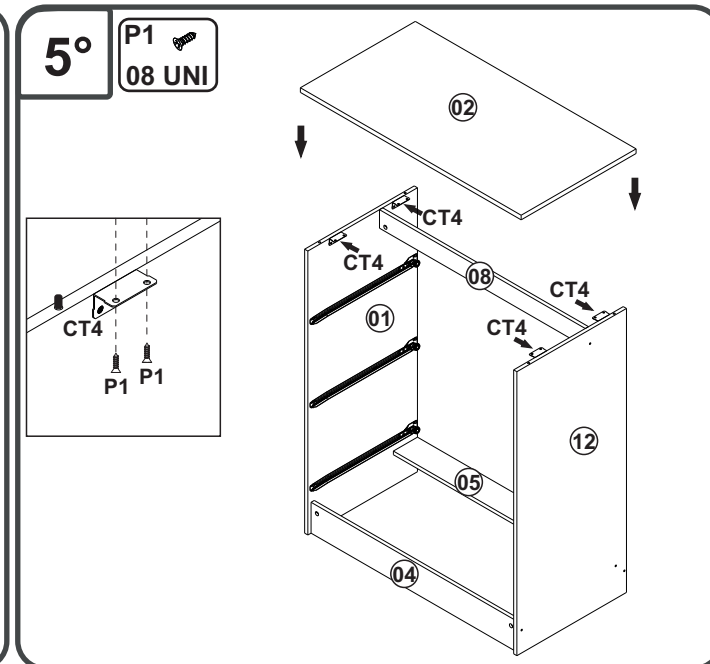
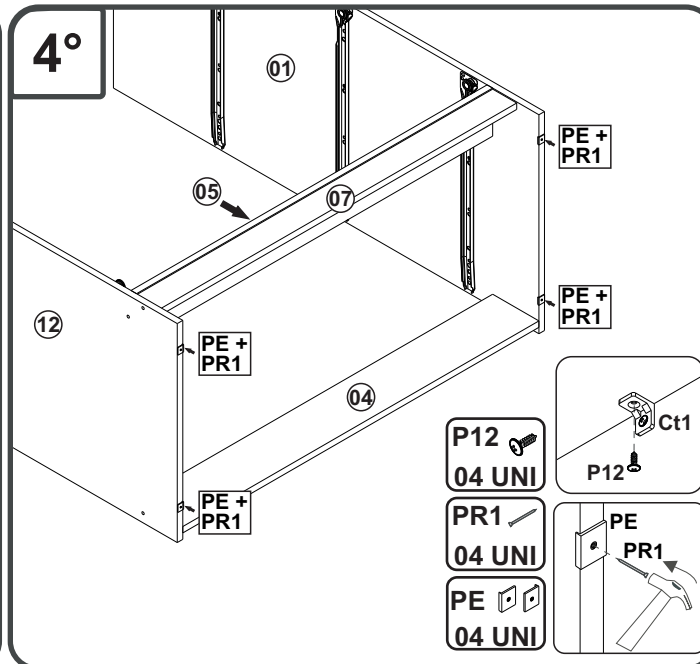
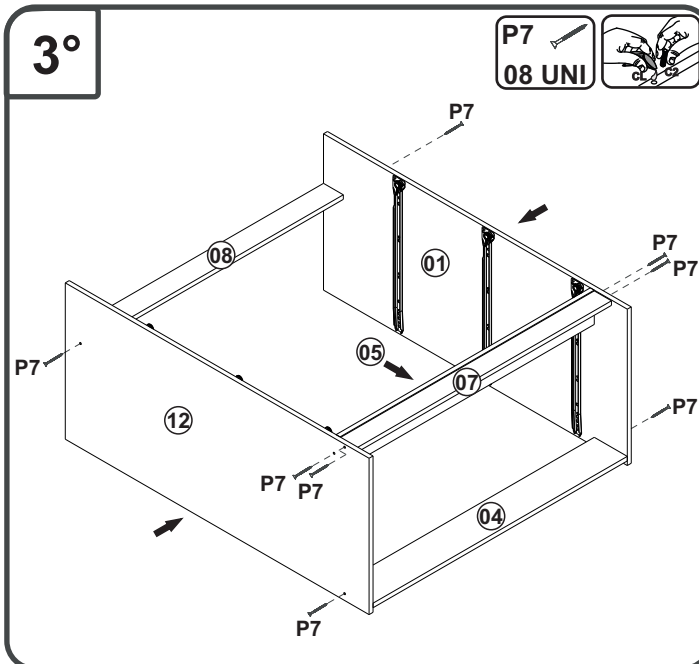
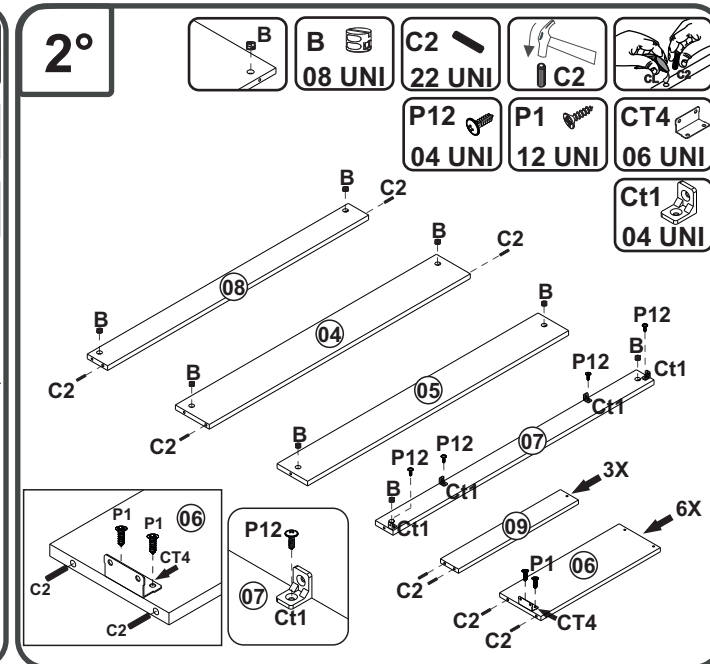
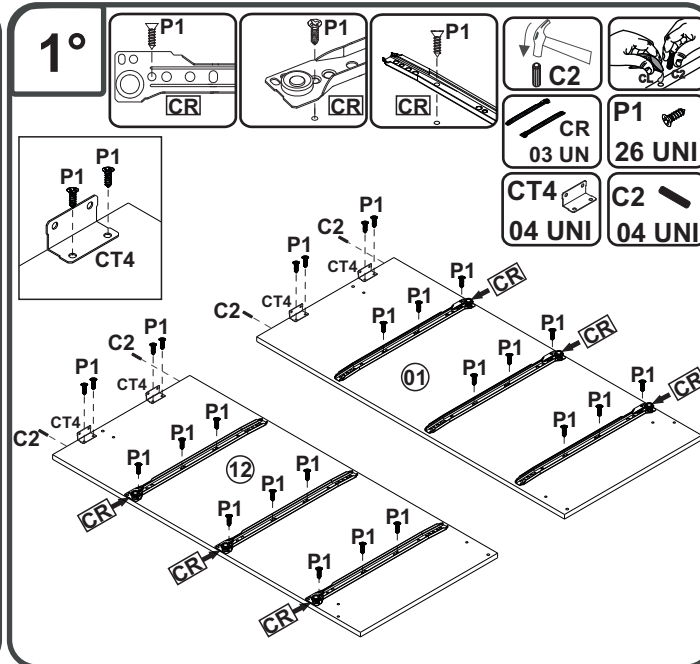
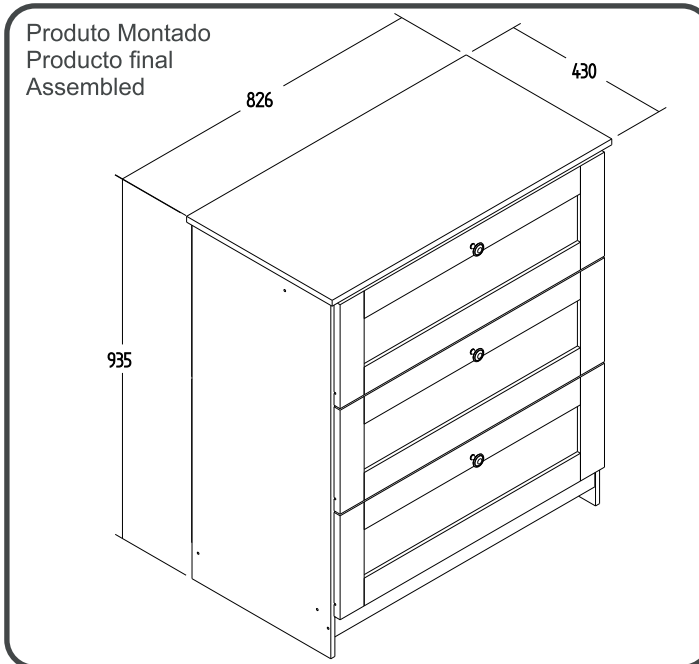

CM4300 - CÔMODA

Manual de Montagem
 Assembly Instructions
 Instrucción de Montaje

decibal[®]
 móveis

6°

Pr1
 30 UNI

7°

3X

P1
 04 UNI

8°

3X

PX
 01 UNI

P16
 01 UNI

P38
 04 UNI

9°

3X

PR1
 12 UNI

P38
 01 UNI

10°

3X

P1
 06 UNI

! PESO SUPORTADO DISTRIBUÍDO. PESO SOPORTADO DISTRIBUIDO. DISTRIBUTED SUPPORTED WEIGHT.

8Kg
 DISTRIBUÍDO

Instrucción de Montaje

Relação de Peças/ Relación de Piezas/Parts List

N°	CÓDIGO/CODE	DESCRIÇÃO/DESCRIPCIÓN/DESCRIPTION	QTD/CANT	VOL.	
1	0570553	LATERAL DIR/LATERAL/SIDE	920X410X12MM	1	1
2	0570552	TAMPO/TAPA/TOP	826X430X15MM	1	1
3	0571156	FRENTE GAV/FRENTE CAJÓN/DRAWER FRONT	781X266X18MM	3	1
4	0570550	RODAPE TRS/ZÓCALO/BASEBOARD	770X100X12MM	1	1
5	0570551	TRAVESSA RPE/TRAVIESSA/TRVERSE	770X100X12MM	1	1
6	0570554	LAT GAV/LATERAL CAJÓN/DRAWER SIDE	400X138X12MM	6	1
7	0570549	RODAPE FRT/ZÓCALO/BASEBOARD	770X52X12MM	1	1
8	0570909	TRAVESSA TP/TRAVIESSA/TRVERSE	770X60X12MM	1	1
9	0570557	TRAVESSA GV/TRAVIESSA/TRVERSE	400X60X12MM	3	1
10	0570556	FUNDO GAV/FONDO CAJÓN/DRAWER BOTTOM	744X405X2, 8MM	3	1
11	0570555	BATENTE/REVÉS CAJÓN/DRAWER BACK	721X138X12MM	3	1
12	0570548	LATERAL ESQ/LATERAL/SIDE	920X410X12MM	1	1
13	0570558	COSTA/REVÉS/BACK	790X418X2, 8MM	2	1

Ferramentas necessárias
Necessary tools
Herramientas necesarias

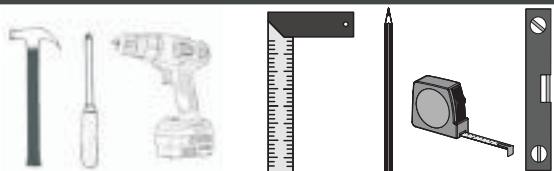

ATENÇÃO!!!! montadores e consumidores
* Ajustar o torque da parafusadeira para não danificar as peças escareando o parafuso *

ATENCIÓN!!!! montadores e consumidores
* Ajuste el torque del destornillador para no dañar las piezas avallanando el tornillo *

ATTENTION!!!! assemblers and consumers
* Adjust the torque of the screwdriver so as not to damage the parts by countersinking the screw *

ATENÇÃO!!!! montadores e consumidores

* Para limpar o móveis utilize somente um pano úmido (umedecido em água pura ou água com sabão neutro).

Depois, passe um pano seco. Evite a umidade excessiva.

* Evite usar álcool, água sanitária, detergente e outros produtos químicos, mesmo diluídos em água.

* Não utilize produtos abrasivos de nenhuma espécie

ATENCIÓN!!!! montadores e consumidores

* Para limpiar el mueble utilice solamente un paño húmedo (humedecido con agua limpia o con un jabón suave).

A continuación, utilice un paño seco. Evite el exceso de humedad.

* Evite uso de alcohol, hipoclorídoro solución basada, detergente y otros productos químicos, mismo diluídos en agua.

No utilice productos abrasivos de ningún tipo.

ATTENTION!!!! assemblers and consumers

* To clean the furniture, use only a damp cloth (humidify it only in pure water ou water and neutral soap).

After, use a dry cloth. Avoid excessive humidity.

* Avoid using alcohol, bleach, detergent and other chemical products, even diluted in water. Do not use any kind of abrasive cleaning agents to clean the furniture.

The use of such products may jeopardize the ?nal characteristics of the furniture.

www.decibal.com.br



120 min.



2 montador
2 ajustador
2 fitter

CM4300 - CÔMODA









Manual de Montagem
Assembly Instructions
Instrucción de Montaje

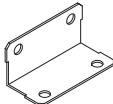

Escala (1:1)

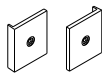
LEGENDA	DESCRIÇÃO/DESCRIPCIÓN/DESCRIPTION	CÓDIGO	QUANT.
P1	 PARAFUSO/TORNILLO/SCREW 3X12	01328	76
P7	 PARAFUSO/TORNILHO/SCREW 4X45	01318	08
P12	 PARAFUSO/TORNILLO/SCREW 3,5X13	09927	08
P16	 PARAFUSO/TORNILLO/SCREW 3,5X30	13502	03
P38	 PARAFUSO/TORNILLO/SCREW 3,5X40	12425	15
PR1	 PREGO/CLAVO/NAIL 10X10	01330	70
B	BUCJA/BUJE/BUCHING 	02734	08
C2	 CAVILHA/TARUGO/DOWEL 6X30 MM	01211	28

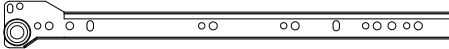
Escala (N/A)

LEGENDA	DESCRIÇÃO/DESCRIPCIÓN/DESCRIPTION	CÓDIGO	QUANT.
CL	 COLA/PEGAMENTO/GLUE	01213	01
ET	 ETIQUETA LOGO DECIBAL/LABEL DECIBAL	01312	01
Ct4	 CANTONEIRA/PIEZA L/SHEET	03110	10
Ct1	 CANTONEIRA/PIEZA L/SHEET	03077	04
PE	PE/PATA/FOOT 15X15MM 	01367	04
AD	 ADESIVO/ADHESIVO/ADHESIVE	15mm	08
CR	 CORREDICA/CORREDERA/METTALIC SLIDE 350MM	01225	03
PX	PUXADOR/PEGADOR/HANDLE 	13039	03
PF	 PERFIL/PROFILE/PERFIL 765 MM	12881	01



MN1010 - MESA NOITE

Manual de Montagem
 Assembly Instructions
 Instrucción de Montaje



Produto Montado
 Producto final
 Assembled

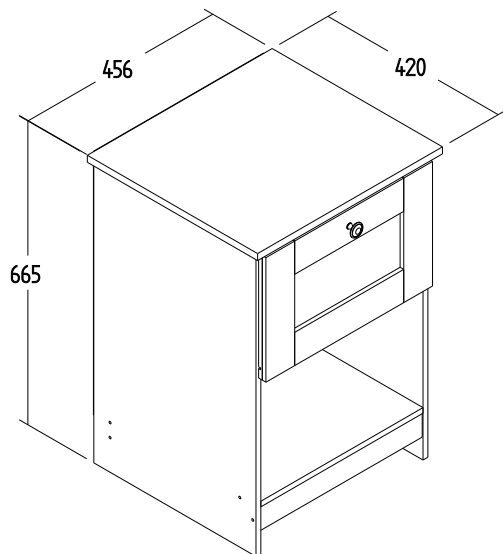

1°

P1	CR	C2	CR	P1	CT4
P1	CR	C2	CR	P1	CT4
P1	CR	C2	CR	P1	CT4

CR 01 UN
 P1 10 UNI
 CT4 02 UNI
 C2 04 UNI

2°

B	B	C2	C2	P12	P1	CT4
B	B	C2	C2	P12	P1	CT4
B	B	C2	C2	P12	P1	CT4

B 08 UNI
 C2 06 UNI
 P12 03 UNI
 P1 04 UNI
 CT4 02 UNI
 Ct1 03 UNI

3°

PR1	PE	P12	P7	Ct1
PR1	PE	P12	P7	Ct1
PR1	PE	P12	P7	Ct1

PR1 04 UNI
 PE 04 UNI
 P12 03 UNI
 P7 08 UNI

4°

P1	Ct4
----	-----

P1 04 UNI

5°

Pr1

Pr1 27 UNI

MN1010 - MESA NOITE

Manual de Montagem
Assembly Instructions
Instrucción de Montaje

decibal[®]
móveis

6°

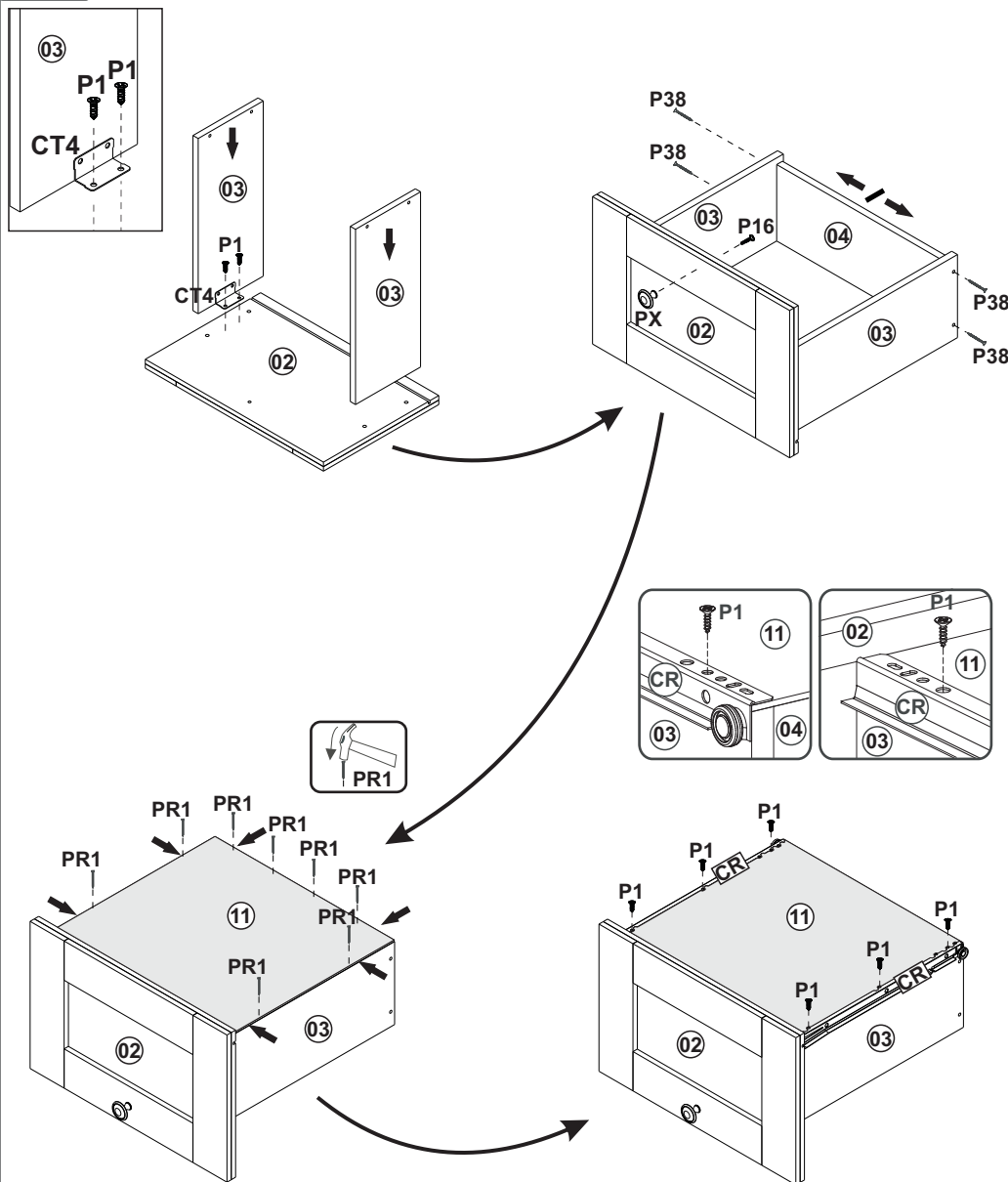

Instrucción de Montaje

Relação de Peças/ Relación de Piezas/Parts List

N°	CÓDIGO/CODE	DESCRIÇÃO/DESCRIPCIÓN/DESCRIPTION	QTD/CANT	VOL.
1	0570510	LATERAL DIR/LATERAL/SIDE	650X400X12MM	1
2	0571160	FRENTE GAV/FRENTE CAJÓN/DRAWER FRONT	411X266X18MM	1
3	0570520	LAT GAV/LATERAL CAJÓN/DRAWER SIDE	350X150X12MM	2
4	0570521	BATENTE/REVÉS CAJÓN/DRAWER BACK	351X138X12MM	1
5	0570507	RODAPE TRS/ZÓCALO/BASEBOARD	400X100X12MM	1
6	0570506	RODAPE FRT/ZÓCALO/BASEBOARD	400X52X12MM	1
7	0570508	BASE	400X400X12MM	1
8	0570509	TAMPO/TAPA/TOP	456X420X15MM	1
9	0570505	LATERAL ESQ/LATERAL/SIDE	650X400X12MM	1
10	0570511	COSTA/REVÉS/BACK	563X420X2, 8MM	1
11	0570522	FUNDO GAV/FONDO CAJÓN/DRAWER BOTTOM	374X355X2, 8MM	1

ATENÇÃO!!!! montadores e consumidores
 * Para limpar o móveis utilize somente um pano úmido (umedecido em água pura ou água com sabão neutro). Depois, passe um pano seco. Evite a umidade excessiva.
 * Evite usar álcool, água sanitária, detergente e outros produtos químicos, mesmo diluídos em água.
 * Não utilize produtos abrasivos de nenhuma espécie

ATENCIÓN!!!! montadores e consumidores
 * Para limpiar el mueble utilice solamente un paño húmedo (humedecido con agua limpia o con un jabón suave). A continuación, utilice un paño seco. Evite el exceso de humedad.
 * Evite uso de alcohol, hipocloridro solución basada, detergente y otros productos químicos, mismo diluídos en agua. No utilice productos abrasivos de ningún tipo.

ATTENTION!!!! assemblers and consumers
 * To clean the furniture, use only a damp cloth (humidify it only in pure water ou water and neutral soap). After, use a dry cloth. Avoid excessive humidity.
 * Avoid using alcohol, bleach, detergent and other chemical products, even diluted in water. Do not use any kind of abrasive cleaning agents to clean the furniture.
 The use of such products may jeopardize the ?nal characteristics of the furniture.

! PESO SOPORTADO DISTRIBUÍDO. PESO SOPORTADO DISTRIBUÍDO. DISTRIBUTED SUPPORTED WEIGHT.

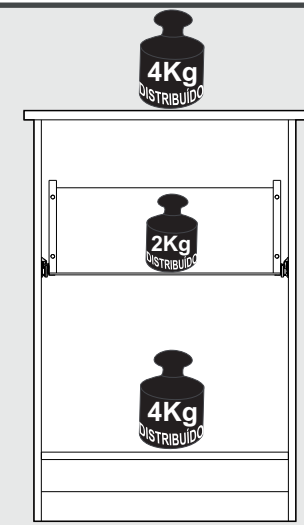









MN1010 - MESA NOITE









Manual de Montagem
Assembly Instructions
Instrucción de Montaje

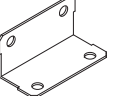

Escala (1:1)

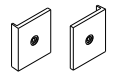
LEGENDA	DESCRIÇÃO/DESCRIPCIÓN/DESCRIPTION	CÓDIGO	QUANT.
P1	 PARAFUSO/TORNILLO/SCREW 3X12	01328	28
P7	 PARAFUSO/TORNILLO/SCREW 4X45	01318	08
P12	 PARAFUSO/TORNILLO/SCREW 3,5X13	09927	06
P16	 PARAFUSO/TORNILLO/SCREW 3,5X30	13502	01
P38	 PARAFUSO/TORNILLO/SCREW 3,5X40	12425	04
PR1	 PREGO/CLAVO/NAIL 10X10	01330	35
B	 BUCJA/BUJE/BUCHING	02734	08
C2	 CAVILHA/TARUGO/DOWEL 6X30 MM	01211	11

Escala (N/A)

LEGENDA	DESCRIÇÃO/DESCRIPCIÓN/DESCRIPTION	CÓDIGO	QUANT.
CL	 COLA/PEGAMENTO/GLUE	01213	01
ET	 ETIQUETA LOGO DECIBAL/LABEL DECIBAL	01312	01
Ct4	 CANTONEIRA/PIEZA L/SHEET	03110	04
Ct1	 CANTONEIRA/PIEZA L/SHEET	03077	03
PE	 PE/PATA/FOOT 15X15MM	01367	04
AD	 ADESIVO/ADHESIVO/ADHESIVE	15mm	08
CR	 CORREDICA/CORREDERA/METTALIC SLIDE 350MM	01225	01
PX	 PUXADOR/PEGADOR/HANDLE	13039	01

Ferramentas necessárias
Necessary tools
Herramientas necesarias



www.decibal.com.br

ATENÇÃO!!!! montadores e consumidores
* Ajustar o torque da parafusadeira para não danificar as peças escareando o parafuso *

ATENCIÓN!!!! montadores e consumidores
* Ajuste el torque del destornillador para no dañar las piezas avallanando el tornillo *

ATTENTION!!!! assemblers and consumers
* Adjust the torque of the screwdriver so as not to damage the parts by countersinking the screw *

Medida em mm

