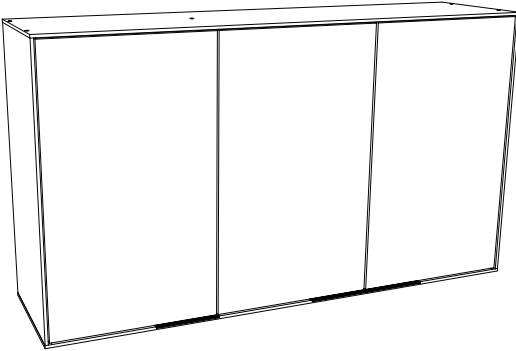
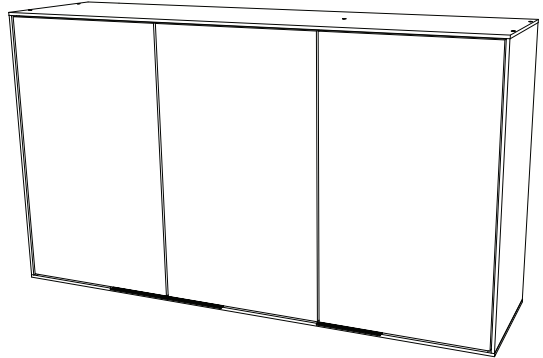

HENNInd. e Com. de Móveis Henn
Mondai - SC - Brasil

☎ +55 49 3674.3500

📷 📱 @moveishenn
www.henn.com.br**INSTRUÇÕES DE
MONTAGEM**INSTRUCCIONES DE MONTAJE
ASSEMBLY INSTRUCTIONS**AÉREO 03 PORTAS 1200MM FINEZE | FINEZE AERIAL DE 3 PUERTAS Y 1200MM |
3-DOOR 1200MM FINEZE AERIAL****C654-133 Areia HP****OPÇÃO 1 | OPCIÓN 1 | OPTION 1****OPÇÃO 2 | OPCIÓN 2 | OPTION 2****AVISO**

Para limpeza de seu móvel, use uma flanela seca ou umedecida, e não utilize produtos químicos que possam danificar seu produto.

SISTEMA DE MONTAGEM

O sistema de montagem dos produtos, funciona de acordo com a ordem crescente dos números indicados no desenho. Ex: 01, 02, 03, 04... até a conclusão da montagem.

ASSISTÊNCIA TÉCNICA

Para solicitação de Assistência Técnica você consumidor deverá entrar em contato com o Lojista o qual você realizou a compra deste produto e solicitar a assistência técnica das peças avariadas. A garantia abrange todas as peças, partes e componentes que eventualmente venham apresentar defeito de fabricação no prazo de 03 (três) meses, contando a partir da entrega do produto ao consumidor, mediante nota fiscal de compra. Se houver qualquer alteração na estrutura do produto ou ocorrer defeito por negligência do montador/consumidor em relação a instrução de montagem e manuseio, não será fornecido assistência técnica gratuita.

ADVERTENCIA

Para limpieza de su móvil, use una franela seca o húmeda, y no utilice productos químicos que puedan dañar su producto.

SISTEMA DE MONTAJE

El sistema de montaje de los productos funciona de acuerdo con el orden creciente de los números indicados en el dibujo. Ej.: 01, 02, 03, 04... hasta la conclusión del montaje.

ASISTENCIA TÉCNICA

Para solicitar Asistencia Técnica, el consumidor debe comunicarse con el Comercio que usted realizó la compra de este producto y solicita asistencia técnica para las partes dañadas. La garantía cubre todas las partes, piezas y componentes que eventualmente puedan presentar defecto de fabricación en el plazo de 03 (tres) meses, contados a partir de la entrega del producto al consumidor, mediante factura de compra. Si se produce algún cambio en la estructura del producto o se produce un defecto por negligencia del montador/consumidor en relación con las instrucciones de montaje y manipulación, no se prestará asistencia técnica gratuita.

NOTICE

To clean your furniture, use a dry or wet cloth, and do not use chemicals that may damage your product.











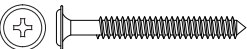

ASSEMBLY SYSTEM

The products' assembly system works according to the increasing order of the indicated numbers. For example: 01, 02, 03, 04 ... to the end of the assembly.

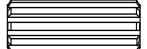
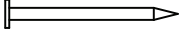
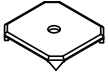
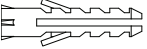
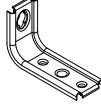
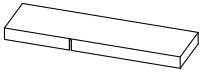
TECHNICAL ASSISTANCE

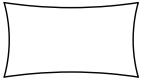
To request Technical Assistance, the consumer must contact the retailer from whom you purchased this product and request technical assistance for the damaged parts. The warranty covers all parts, parts and components that may eventually present a manufacturing defect within a period of 03 (three) months, counting from the delivery of the product to the consumer, by means of a purchase invoice. If there is any change in the structure of the product or defect occurs due to negligence of the assembler/consumer in relation to the assembly and handling instruction, free technical assistance will not be provided.

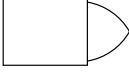
ACESSÓRIOS | ACCESORIOS | ACCESSORIES

<p>A x3</p>  <p>Parafuso 5,0x50mm FLA.</p>	<p>B x13</p>  <p>Parafuso 3,5x40mm CHT.</p>	<p>C x42</p>  <p>Parafuso 4,0x14mm CHT.</p>	<p>D x6</p>  <p>Parafuso 3,5x12mm CHT.</p>
<p>E x4</p>  <p>Parafuso União Fêmea 27mm CHT</p>	<p>F x4</p>  <p>Parafuso União Macho 12mm CHT</p>	<p>G x12</p>  <p>Cavilha Plástica 8x25mm</p>	<p>H x54</p>  <p>Prego 10x10mm</p>
<p>I x14</p>  <p>Fixador de Fundo</p>	<p>J x3</p>  <p>Bucha Plástica 8mm</p>	<p>K x3</p>  <p>Suporte de Fixação</p>	<p>L x3</p>  <p>Proteção Cantoneira</p>
<p>M x3</p>  <p>Perfil Puxador RX014 150mm</p>	<p>N x6</p>  <p>Dob 35mm POP Alta C/Amortecedor + Calço Fixo</p>	<p>O x1</p>  <p>Sachê de Cola</p>	<p>P x12</p>  <p>Adesivo Tapa Parafuso 10mm</p>
<p>Q x2</p>  <p>Giz de Correção</p>	<p>R x1</p>  <p>Etiqueta Resinada Henn</p>		

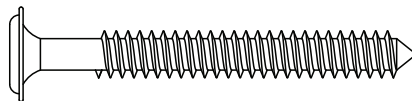
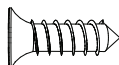
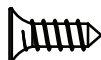
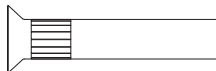
PARAFUSOS EM ESCALA 1:1 | TORNILLOS A ESCALA 1:1 | 1:1 SCALE SCREWS**A****B****C****D****E****F**

LISTA DE PEÇAS | LISTA DE PIEZAS | LIST OF PIECES

Item	Caixa Caja Box	Qty Ctd Qty	Descrição Descripción Description	Dimensões (mm) Dimensiones (mm) Dimensions (mm)		
				Comprimento Largo Length	Largura Ancho Width	Espessura Grosor Thickness
1	1/1	1	BASE BASE BASE	1200	312	15
2	1/1	1	DIVISÃO DIVISIÓN DIVISION	645	295	15
3	1/1	1	PRATELEIRA ESTANTE SHELF	772	295	15
4	1/1	1	PRATELEIRA MENOR ESTANTE MÁS PEQUEÑO SMALLER SHELF	382	295	15
5	1/1	2	LATERAL DIREITA ESQUERDA LATERAL DERECHA IZQUIERDA RIGHT LEFT SIDE	661	312	15
6	1/1	1	TAMPO TAPA TOP	1200	312	15
7	1/1	1	FUNDO LATERAL FONDO LATERAL SIDE BACKGROUND	669	400	3
8	1/1	2	FUNDO FONDO BOTTOM	791	334	3
9	1/1	3	PORTA PUERTA DOOR	655	390	15

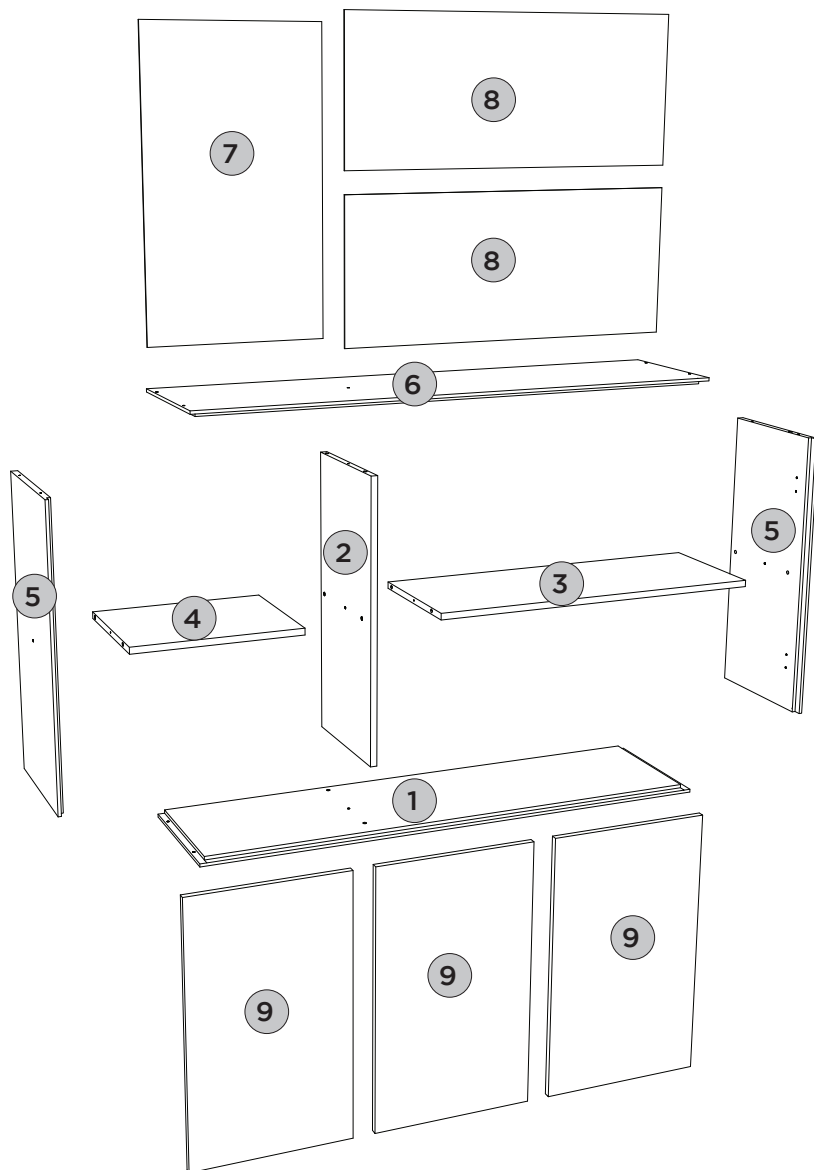

REQUISITOS PARA MONTAGEM

REQUISITOS PARA LA MONTAJE | ASSEMBLY REQUIREMENTS.

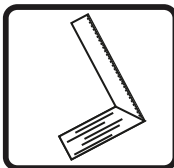
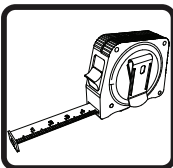
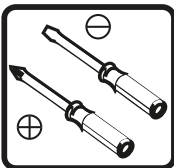
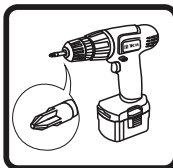

Imagens meramente ilustrativas, não acompanha o produto.





Imágenes ilustrativas, no incluidas con el producto.

Illustrative images, not included with the product.

PEÇAS REQUERIDAS

2	DIVISÃO	x1
3	PRATELEIRA	x1
4	PRATELEIRA MENOR	x1
9	PORTA	x3

ACESSÓRIOS REQUERIDOS

C		12
G		12
N		06
O		

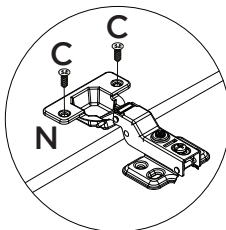
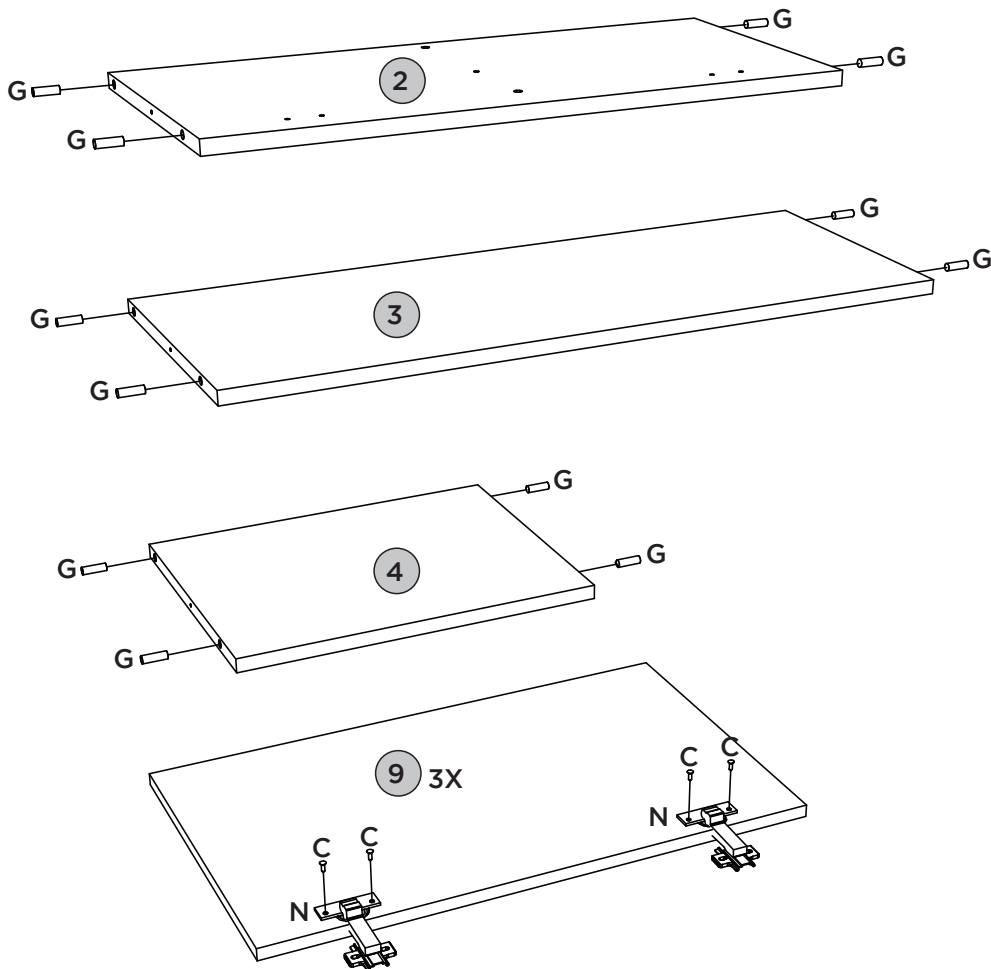
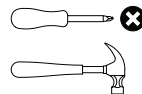
FERRAMENTAS NECESSÁRIAS

PEÇAS REQUERIDAS

1	BASE	x1
2	DIVISÃO	x1
3	PRATELEIRA	x1
5	LATERAL DIREITA ESQUERDA	x1

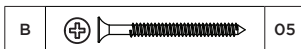
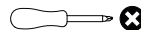
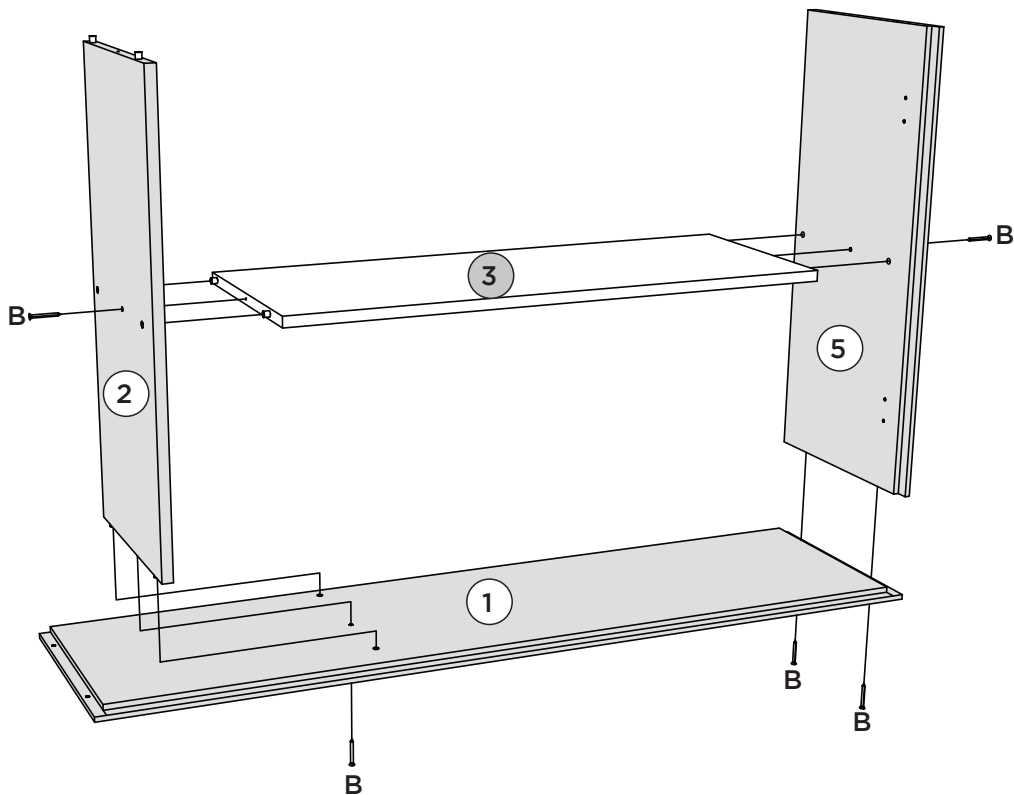
ACESSÓRIOS REQUERIDOS

FERRAMENTAS NECESSÁRIAS

OPÇÃO 1 | OPCIÓN 1 | OPTION 1

MONTAGEM 2 | MONTAJE 2 | ASSEMBLY 2

ITM/C654-

PEÇAS REQUERIDAS

4	PRATELEIRA MENOR	x1
5	LATERAL DIREITA ESQUERDA	x1

ACESSÓRIOS REQUERIDOS

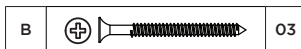

FERRAMENTAS NECESSÁRIAS

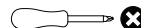

OPÇÃO 1 | OPCIÓN 1 | OPTION 1

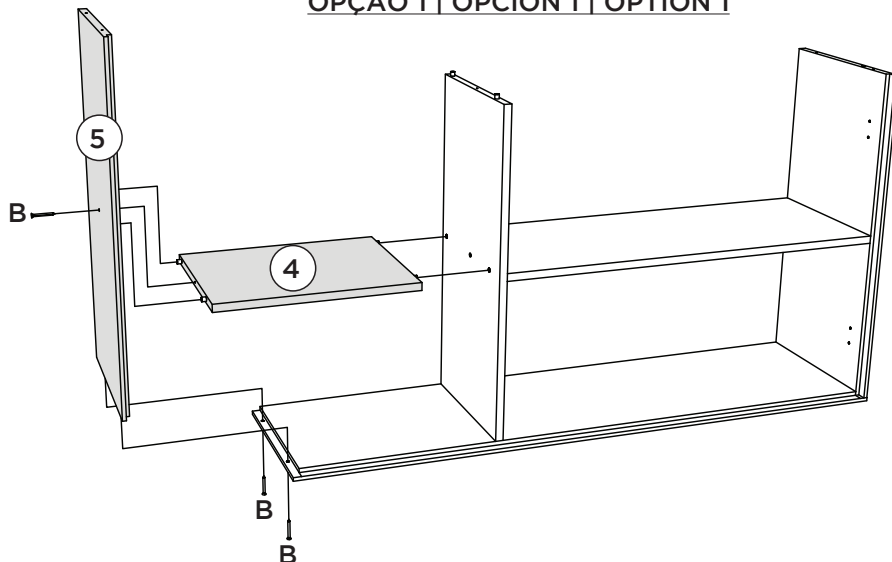

MONTAGEM 3 | MONTAJE 3 | ASSEMBLY 3

PEÇAS REQUERIDAS

6	TAMPO	x1
---	-------	----

ACESSÓRIOS REQUERIDOS

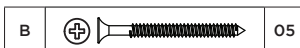

FERRAMENTAS NECESSÁRIAS

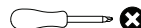

OPÇÃO 1 | OPCIÓN 1 | OPTION 1

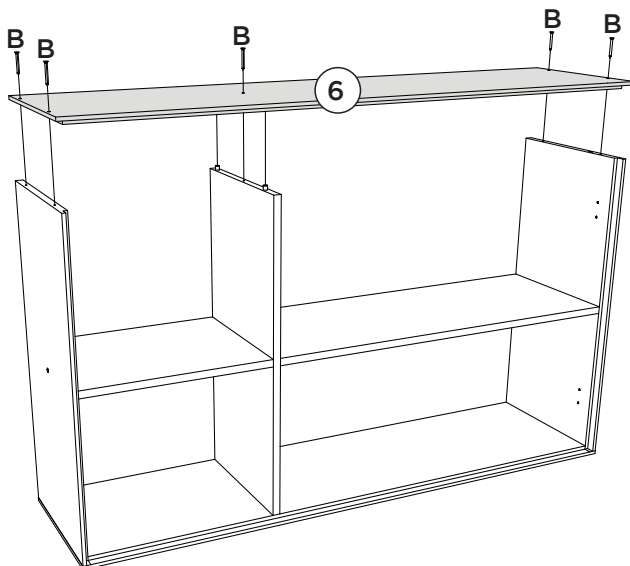



MONTAGEM 4 | MONTAJE 4 | ASSEMBLY 4

ITM/C654-

PEÇAS REQUERIDAS

7	FUNDO LATERAL	x1
8	FUNDO	x2

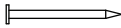
ACESSÓRIOS REQUERIDOS

H		54
I		14

FERRAMENTAS NECESSÁRIAS



OPÇÃO 1 | OPCIÓN 1 | OPTION 1

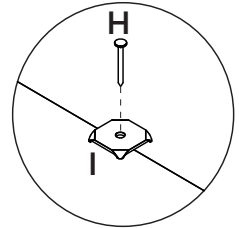
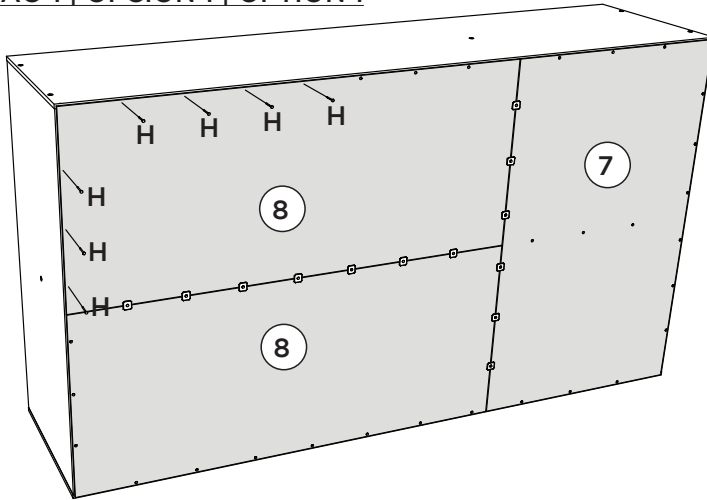



MONTAGEM 5 | MONTAJE 5 | ASSEMBLY 5

PEÇAS REQUERIDAS

9	PORTA	x3
---	-------	----

ACESSÓRIOS REQUERIDOS

C		24
D		06
M		03

FERRAMENTAS NECESSÁRIAS

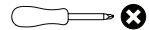

OPÇÃO 1 | OPCIÓN 1 | OPTION 1

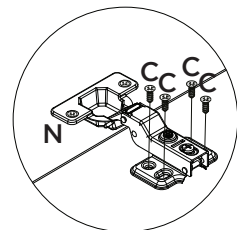
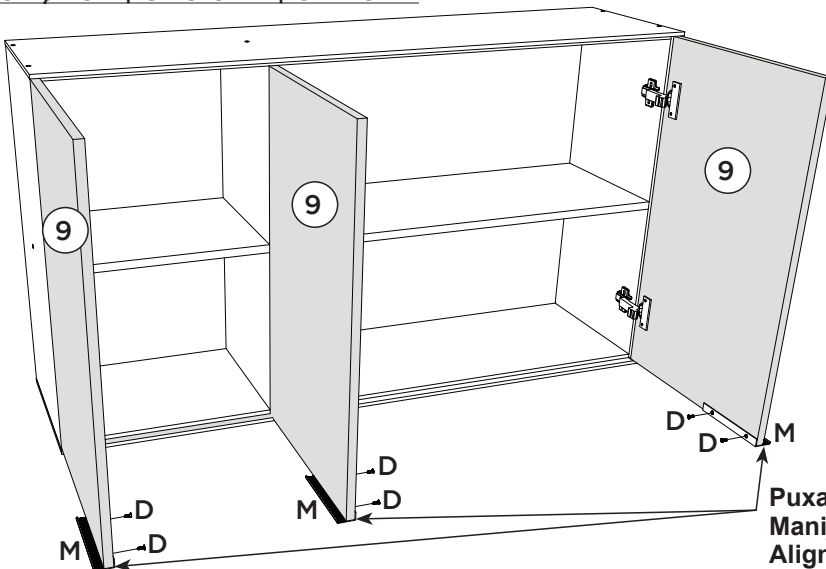

Puxadores alinhados
Manijas alineadas
Aligned handles

ACESSÓRIOS REQUERIDOS

A		03	J		03
C		06	K		03
			L		03

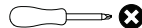
FERRAMENTAS NECESSÁRIAS

OPÇÃO 1 | OPCIÓN 1 | OPTION 1

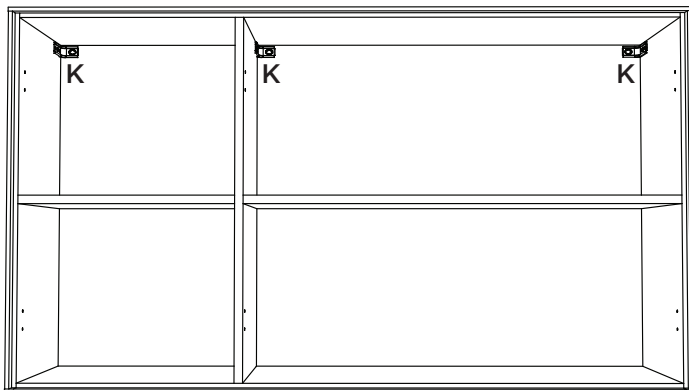
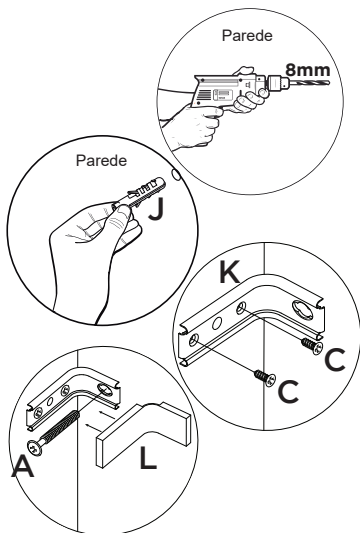

Fixar móvel na Parede
Fijar el mueble a la pared
Secure the furniture to the wall



MONTAGEM 7 | MONTAJE 7 | ASSEMBLY 7

ACESSÓRIOS REQUERIDOS

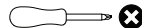
E		04	F		04
---	--	----	---	--	----

FERRAMENTAS NECESSÁRIAS

OPÇÃO 1 | OPCIÓN 1 | OPTION 1

! OBSERVAÇÃO:
 Os parafusos (E e F) devem ser usados somente quando esse módulo for acoplado em outro módulo componível.

Observación:
 Los tornillos (E y F) deben utilizarse únicamente cuando este módulo se acople a otro módulo componible.

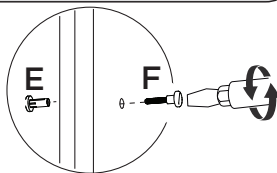
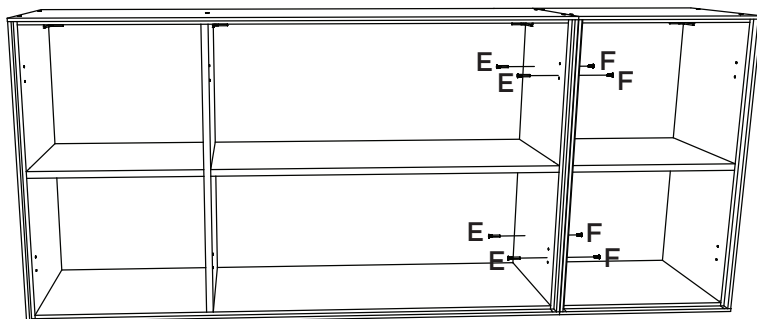
Note:
 Screws (E and F) should only be used when this module is attached to another modular unit.



Fazer furação passante assim que os módulos estiverem alinhados.

Realizar la perforación pasante una vez que los módulos estén alineados.

Drill a through hole once the modules are aligned.

PEÇAS REQUERIDAS

1	BASE	x1
2	DIVISÃO	x1
3	PRATELEIRA	x1
5	LATERAL DIREITA ESQUERDA	x1

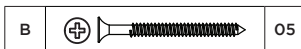
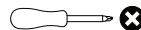
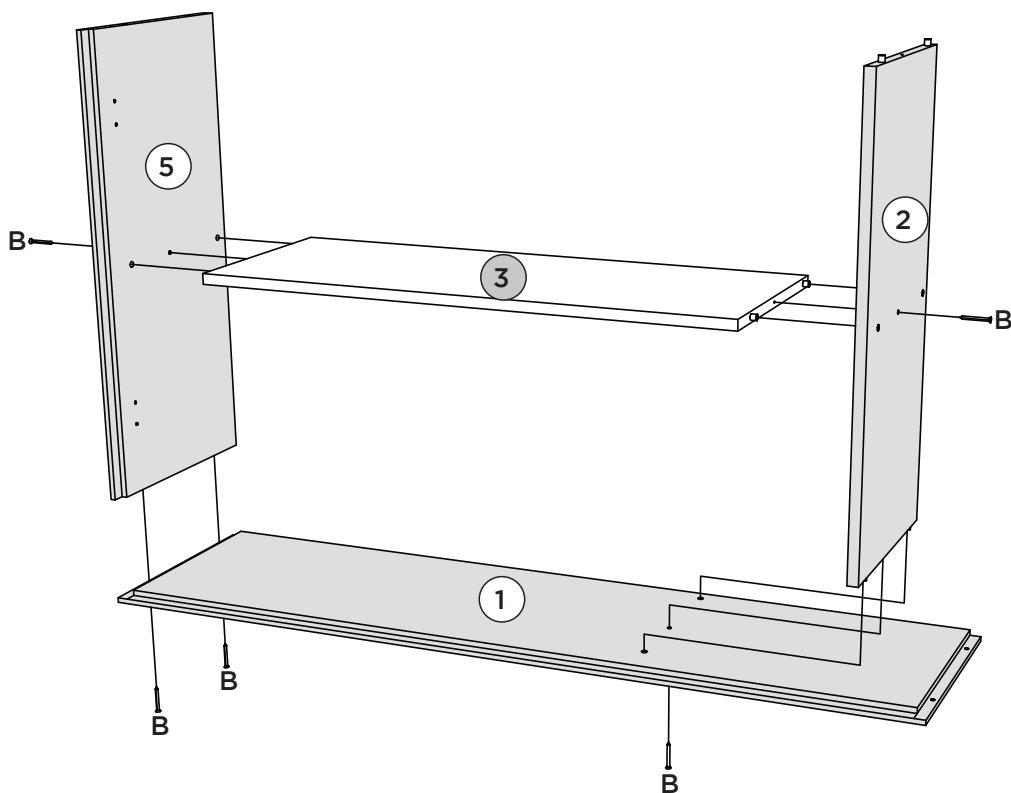
ACESSÓRIOS REQUERIDOS

FERRAMENTAS NECESSÁRIAS

OPÇÃO 2 | OPCIÓN 2 | OPTION 2

MONTAGEM 2 | MONTAJE 2 | ASSEMBLY 2

ITM/C654-

PEÇAS REQUERIDAS

4	PRATELEIRA MENOR	x1
5	LATERAL DIREITA ESQUERDA	x1

ACESSÓRIOS REQUERIDOS

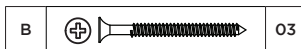

FERRAMENTAS NECESSÁRIAS

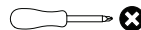

OPÇÃO 2 | OPCIÓN 2 | OPTION 2

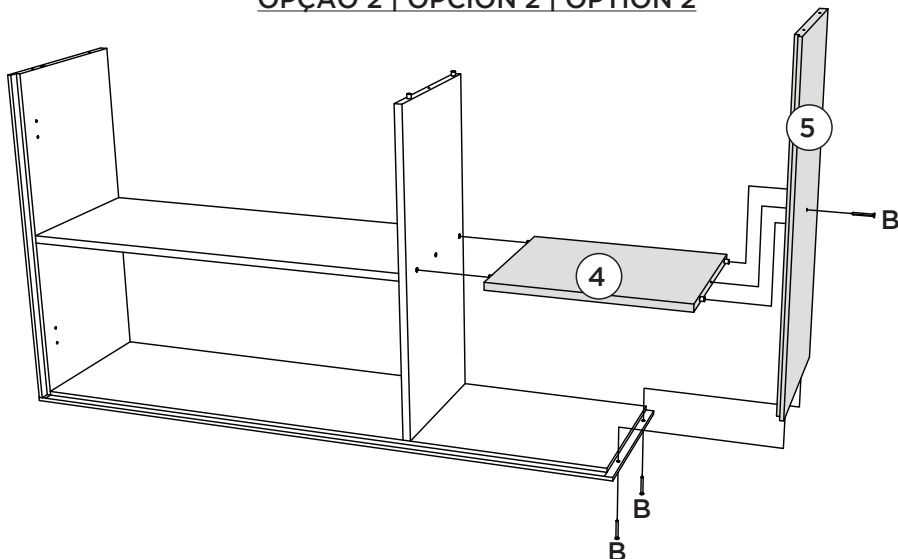

MONTAGEM 3 | MONTAJE 3 | ASSEMBLY 3

PEÇAS REQUERIDAS

6	TAMPO	x1
---	-------	----

ACESSÓRIOS REQUERIDOS

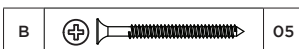

FERRAMENTAS NECESSÁRIAS

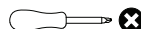

OPÇÃO 2 | OPCIÓN 2 | OPTION 2

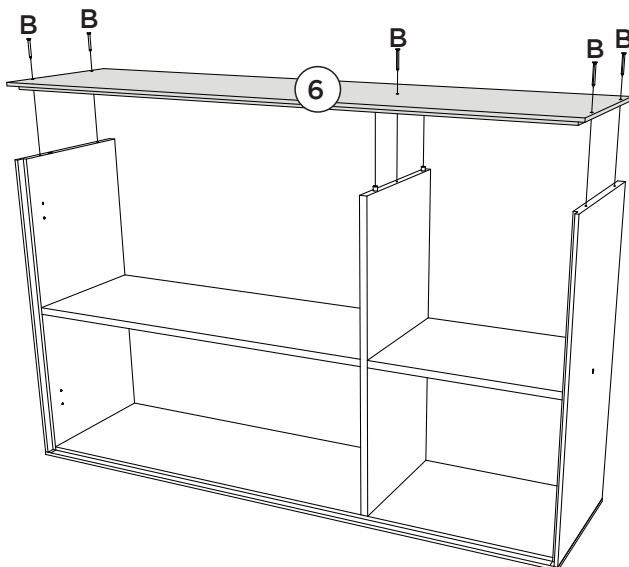



MONTAGEM 4 | MONTAJE 4 | ASSEMBLY 4

ITM/C654-

PEÇAS REQUERIDAS

7	FUNDO LATERAL	x1
8	FUNDO	x2

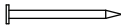
ACESSÓRIOS REQUERIDOS

H		54
I		14

FERRAMENTAS NECESSÁRIAS



OPÇÃO 2 | OPCIÓN 2 | OPTION 2

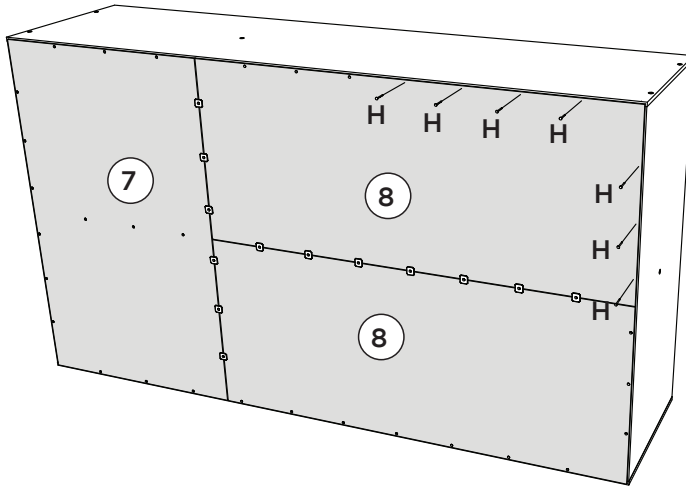



MONTAGEM 5 | MONTAJE 5 | ASSEMBLY 5

PEÇAS REQUERIDAS

9	PORTA	x3
---	-------	----

ACESSÓRIOS REQUERIDOS

C		24
D		06
M		03

FERRAMENTAS NECESSÁRIAS

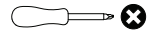

OPÇÃO 2 | OPCIÓN 2 | OPTION 2

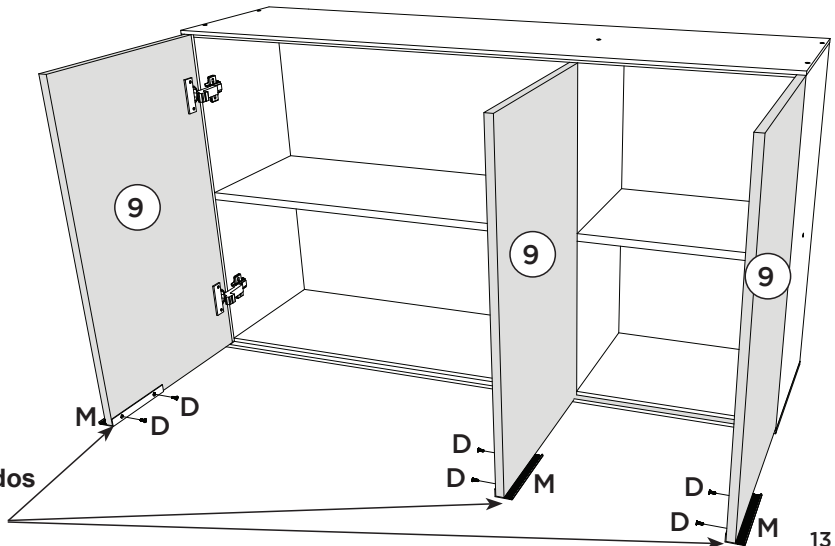
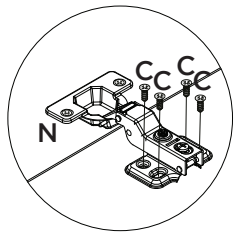

Puxadores alinhados
Manijas alineadas
Aligned handles

ACESSÓRIOS REQUERIDOS

A		03	J		03
C		06	K		03
			L		03

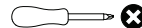
FERRAMENTAS NECESSÁRIAS

OPÇÃO 2 | OPCIÓN 2 | OPTION 2

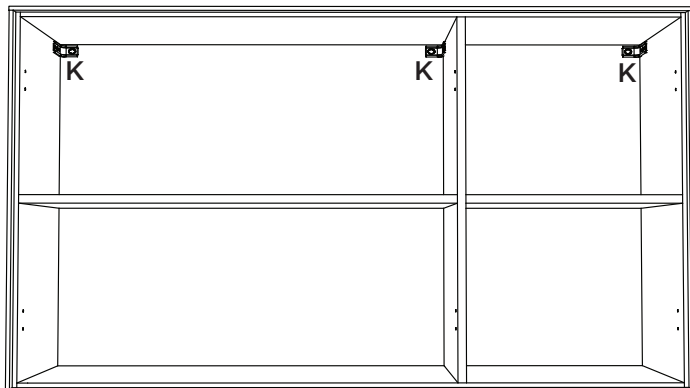
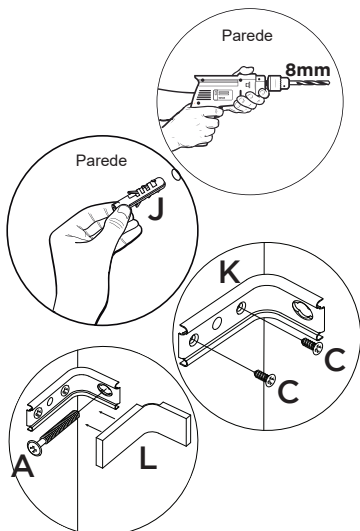

Fixar móvel na Parede
Fijar el mueble a la pared
Secure the furniture to the wall



MONTAGEM 7 | MONTAJE 7 | ASSEMBLY 7

ACESSÓRIOS REQUERIDOS

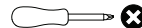
E		04	F		04
---	--	----	---	--	----

FERRAMENTAS NECESSÁRIAS

OPÇÃO 2 | OPCIÓN 2 | OPTION 2
OBSERVAÇÃO:

Os parafusos (E e F) devem ser usados somente quando esse módulo for acoplado em outro módulo componível.

Observación:

Los tornillos (E y F) deben utilizarse únicamente cuando este módulo se acople a otro módulo componible.

Note:

Screws (E and F) should only be used when this module is attached to another modular unit.

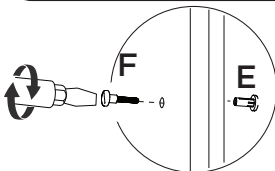



Fazer furação passante assim que os módulos estiverem alinhados.

Realizar la perforación pasante una vez que los módulos estén alineados.

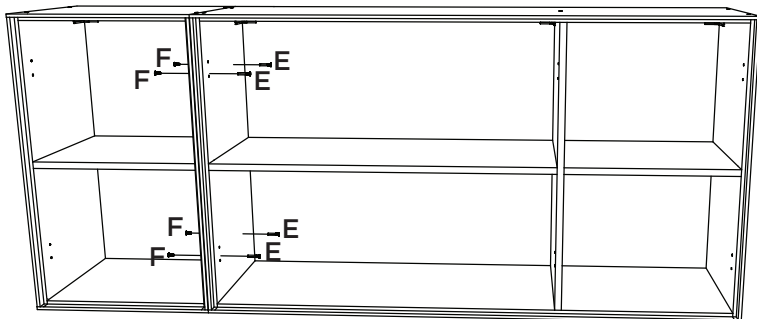
Drill a through hole once the modules are aligned.



ACESSÓRIOS REQUERIDOS

P		12
Q		02
R	HENN	01

Pesos máximos recomendados com carga distribuída.
Peso máximo recomendado con la carga distribuída.
Recommended maximum weight with distributed load.

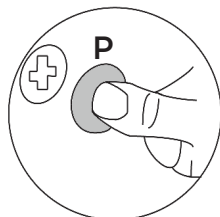
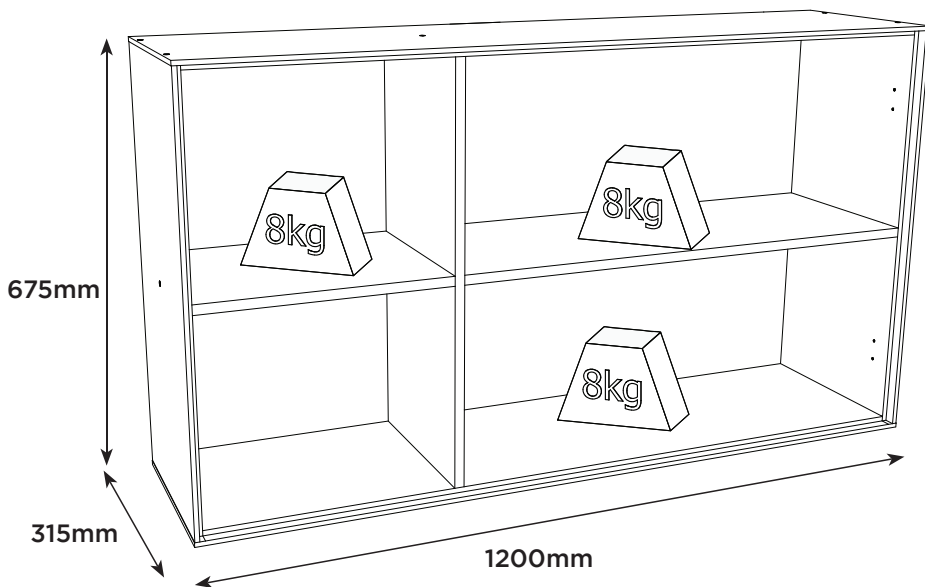

PERFECT CORRECTION
CORRECCIÓN PERFECTA

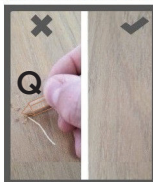



PRODUTO CONCLUÍDO
PRODUCTO TERMINADO
FINISHED PRODUCT

OPÇÃO 1 | OPCIÓN 1 | OPTION 1

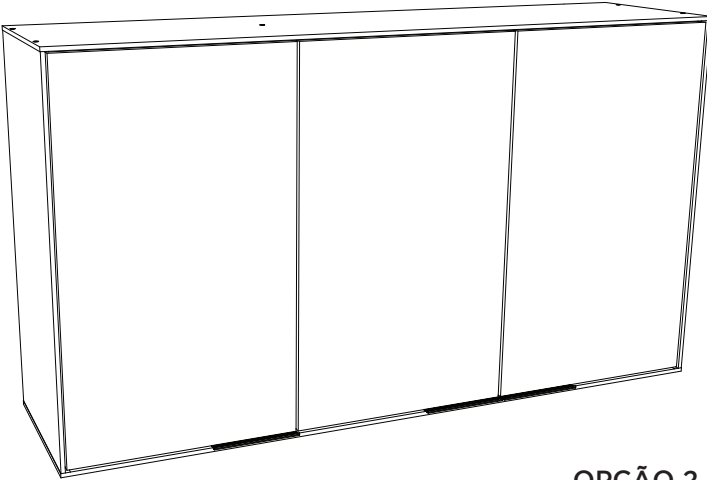

OPÇÃO 2 | OPCIÓN 2 | OPTION 2

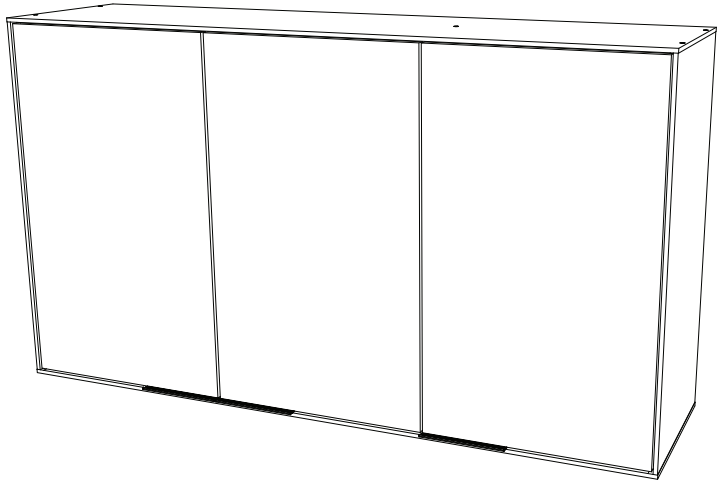

HENNInd. e Com. de Móveis Henn
Mondaí - SC - Brasil

☎ +55 49 3674.3500

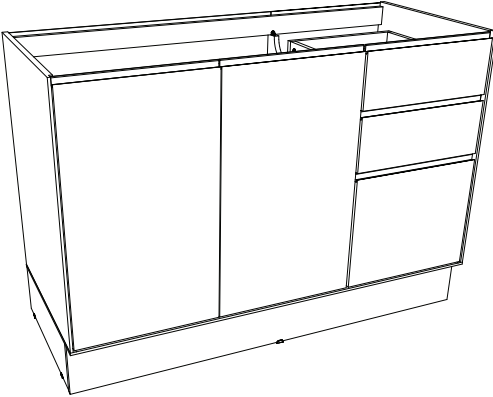
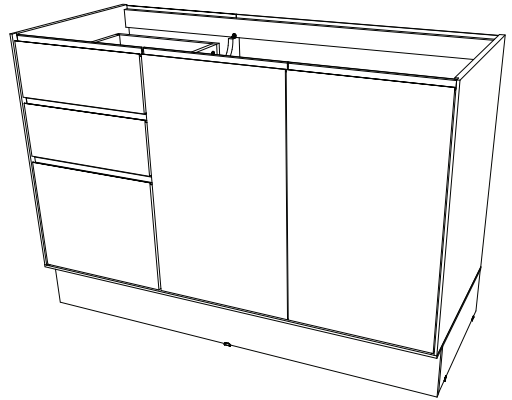
📷 @moveishenn
www.henn.com.br**INSTRUÇÕES DE
MONTAGEM****INSTRUCCIONES DE MONTAJE
ASSEMBLY INSTRUCTIONS****BALCÃO PIA 3 PORTAS 2 GAVETAS FINEZE |
FREGADERO DE ENCIMERA CON 3 PUERTAS Y 2 CAJONES - FINEZE |
COUNTERTOP SINK WITH 3 DOORS AND 2 DRAWERS - FINEZE****C656-133 Areia HP****OPÇÃO 1 | OPCIÓN 1 | OPTION 1****OPÇÃO 2 | OPCIÓN 2 | OPTION 2****AVISO**

Para limpeza de seu móvel, use uma flanela seca ou umedecida, e não utilize produtos químicos que possam danificar seu produto.

SISTEMA DE MONTAGEM

O sistema de montagem dos produtos, funciona de acordo com a ordem crescente dos números indicados no desenho. Ex: 01, 02, 03, 04... até a conclusão da montagem.

ASSISTÊNCIA TÉCNICA

Para solicitação de Assistência Técnica você consumidor deverá entrar em contato com o Lojista o qual você realizou a compra deste produto e solicitar a assistência técnica das peças avariadas. A garantia abrange todas as peças, partes e componentes que eventualmente venham apresentar defeito de fabricação no prazo de 03 (três) meses, contando a partir da entrega do produto ao consumidor, mediante nota fiscal de compra. Se houver qualquer alteração na estrutura do produto ou ocorrer defeito por negligência do montador/consumidor em relação a instrução de montagem e manuseio, não será fornecido assistência técnica gratuita.

ADVERTENCIA

Para limpieza de su móbil, use una franela seca o húmeda, y no utilice productos químicos que puedan dañar su producto.

SISTEMA DE MONTAJE

El sistema de montaje de los productos funciona de acuerdo con el orden creciente de los números indicados en el dibujo. Ej.: 01, 02, 03, 04... hasta la conclusión del montaje.

ASISTENCIA TÉCNICA

Para solicitar Asistencia Técnica, el consumidor debe comunicarse con el Comercio que usted realizó la compra de este producto y solicita asistencia técnica para las partes dañadas. La garantía cubre todas las partes, piezas y componentes que eventualmente puedan presentar defecto de fabricación en el plazo de 03 (tres) meses, contados a partir de la entrega del producto al consumidor, mediante factura de compra. Si se produce algún cambio en la estructura del producto o se produce un defecto por negligencia del montador/consumidor en relación con las instrucciones de montaje y manipulación, no se prestará asistencia técnica gratuita.

NOTICE

To clean your furniture, use a dry or wet cloth, and do not use chemicals that may damage your product.











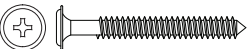





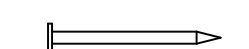
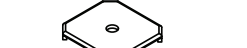





ASSEMBLY SYSTEM

The products' assembly system works according to the increasing order of the indicated numbers. For example: 01, 02, 03, 04 ... to the end of the assembly.

TECHNICAL ASSISTANCE

To request Technical Assistance, the consumer must contact the retailer from whom you purchased this product and request technical assistance for the damaged parts. The warranty covers all parts, parts and components that may eventually present a manufacturing defect within a period of 03 (three) months, counting from the delivery of the product to the consumer, by means of a purchase invoice. If there is any change in the structure of the product or defect occurs due to negligence of the assembler/consumer in relation to the assembly and handling instruction, free technical assistance will not be provided.

ACESSÓRIOS | ACCESORIOS | ACCESSORIES

<p>A x4</p>  <p>Parafuso 5,0x50mm FLA.</p>	<p>B x24</p>  <p>Parafuso 3,5x40mm CHT.</p>	<p>C x100</p>  <p>Parafuso 4,0x14mm CHT.</p>	<p>D x4</p>  <p>Parafuso União Fêmea 27mm CHT</p>
<p>E x4</p>  <p>Parafuso União Macho 12mm CHT</p>	<p>F x32</p>  <p>Cavilha Plástica 8x25mm</p>	<p>G x6</p>  <p>Prego 12x12mm Anelado</p>	<p>H x38</p>  <p>Prego 10x10mm</p>
<p>I x13</p>  <p>Fixador de Fundo</p>	<p>J x8</p>  <p>Parafuso Minifix</p>	<p>K x8</p>  <p>Tambor Minifix</p>	<p>L x12</p>  <p>Cantoneira de Fixação Metal</p>
<p>M x2</p>  <p>Correção Telescópica 350x30mm</p>	<p>N x6</p>  <p>Dob 35mm POP Alta C/Amortecedor + Calço Fixo</p>	<p>O x4</p>  <p>Bucha Plástica 8mm</p>	<p>P x2</p>  <p>Suporte de Fixação</p>
<p>Q x2</p>  <p>Proteção Cantoneira</p>	<p>R x6</p>  <p>Sapata "L" 16x20mm</p>	<p>S x1</p>  <p>Divisor Talheres 398x313mm</p>	<p>T x1</p>  <p>Sachê de Cola</p>
<p>U x4</p>  <p>Adesivo Tapa Parafuso 17mm</p>	<p>V x22</p>  <p>Adesivo Tapa Parafuso 10mm</p>	<p>W x2</p>  <p>Giz de Correção</p>	<p>X x1</p>  <p>Etiqueta Resinada Henn</p>

PARAFUSOS EM ESCALA 1:1 | TORNILLOS A ESCALA 1:1 | 1:1 SCALE SCREWS

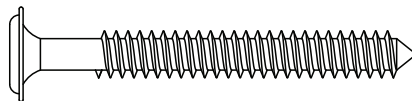
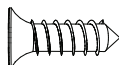
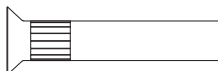
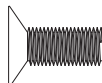
A**B****C****D****E**

ANTES DE INICIAR A MONTAGEM ESCOLHA ENTRE A OPÇÃO 1 OU 2
ANTES DE INICIAR EL MONTAJE, ELIJA ENTRE LA OPCIÓN 1 O 2.
BEFORE STARTING THE ASSEMBLY, CHOOSE BETWEEN OPTION 1 OR 2.

LISTA DE PEÇAS | LISTA DE PIEZAS | LIST OF PIECES

Item	Caixa Caja Box	Qtd Ctd Qty	Descrição Descripción Description	Dimensões (mm) Dimensiones (mm) Dimensions (mm)		
				Comprimento Largo Length	Largura Ancho Width	Espessura Grosor Thickness
1	1/1	1	RODAPÉ FRONTAL ZÓCALO DELANTERO FRONT BASEBOARD	1200	145	15
2	1/1	2	RODAPÉ LATERAL ZÓCALO LATERAL SIDE BASEBOARD	450	145	15
3	1/1	1	RODAPÉ TRASEIRO ZÓCALO TRASERO REAR BASEBOARD	1168	145	15
4	1/1	1	BASE BASE BASE	1200	507	15
5	1/1	1	LATERAL ESQUERDA LATERAL IZQUIERDO LEFT BACK	686	507	15
6	1/1	1	PRATELEIRA ESTANTE SHELF	772	400	15
7	1/1	1	DIVISÃO DIVISIÓN DIVISION	610	490	15
8	1/1	1	TRAVESSA TRASEIRA TRAVESAÑO TRASERO REAR CROSSMEMBER	1169	55	15
9	1/1	1	TRAVESSA FRONTAL BARRA TRANSVERSAL DELANTERA FRONT CROSSBAR	1169	55	15
10	1/1	1	LATERAL DIREITA DE VUELTA A LA DERECHA RIGHT BACK	686	507	15
11	1/1	2	FUNDO FONDO BOTTOM	791	343	3
12	1/1	1	FUNDO LATERAL FONDO LATERAL SIDE BACKGROUND	686	400	3
13	1/1	2	FRENTE DE GAVETA FRENTE DE CAJÓN FRONT OF DRAWER	390	167	15
14	1/1	4	LADO DE GAVETA LADO DEL CAJÓN DRAWER SIDE	400	90	15
15	1/1	2	FUNDO DE GAVETA FONDO DE CAJÓN BOTTOM OF DRAWER	338	411	3
16	1/1	2	RIPA DE TRÁS MALLA DETRÁS REAR LATH	357	90	15
17	1/1	1	PORTA ESQUERDA PUERTA IZQUIERDA LEFT DOOR	680	390	15
18	1/1	1	PORTA DIREITA PUERTA DERECHA RIGHT DOOR	680	390	15
19	1/1	1	PORTA MENOR PUERTA MÁS PEQUEÑA SMALLER DOOR	390	338	15

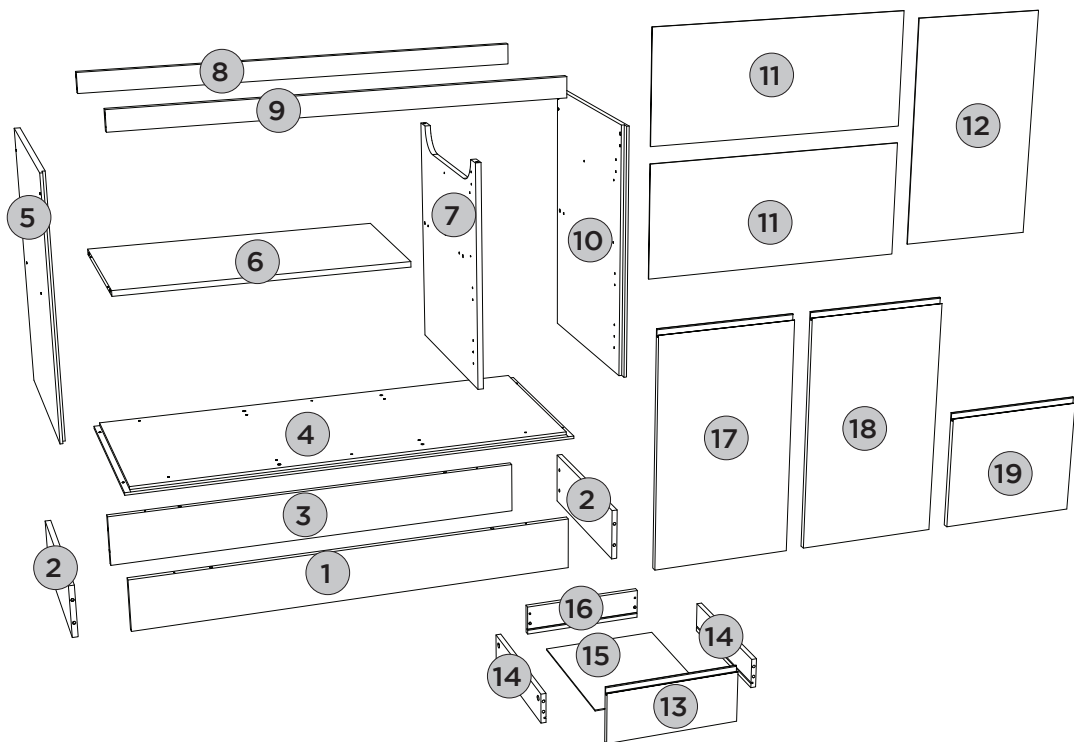

2X

REQUISITOS PARA MONTAGEM

REQUISITOS PARA LA MONTAJE | ASSEMBLY REQUIREMENTS.

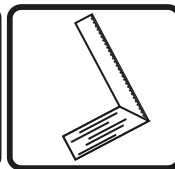
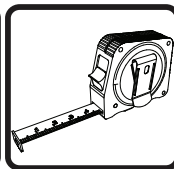
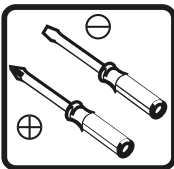
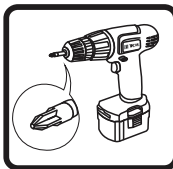

Imagens meramente ilustrativas, não acompanha o produto.





Imágenes ilustrativas, no incluidas con el producto.

Illustrative images, not included with the product.

PEÇAS REQUERIDAS

6	PRATELEIRA	x1
7	DIVISÃO	x1
10	LATERAL DIREITA	x1

ACESSÓRIOS REQUERIDOS

C	 	09
F		08
M		03
T		

FERRAMENTAS NECESSÁRIAS

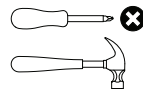



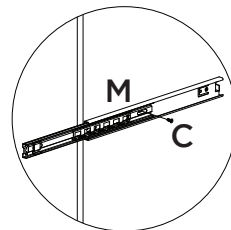
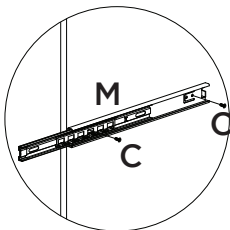
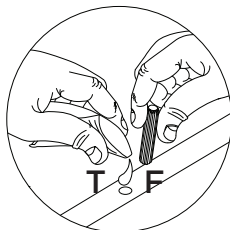
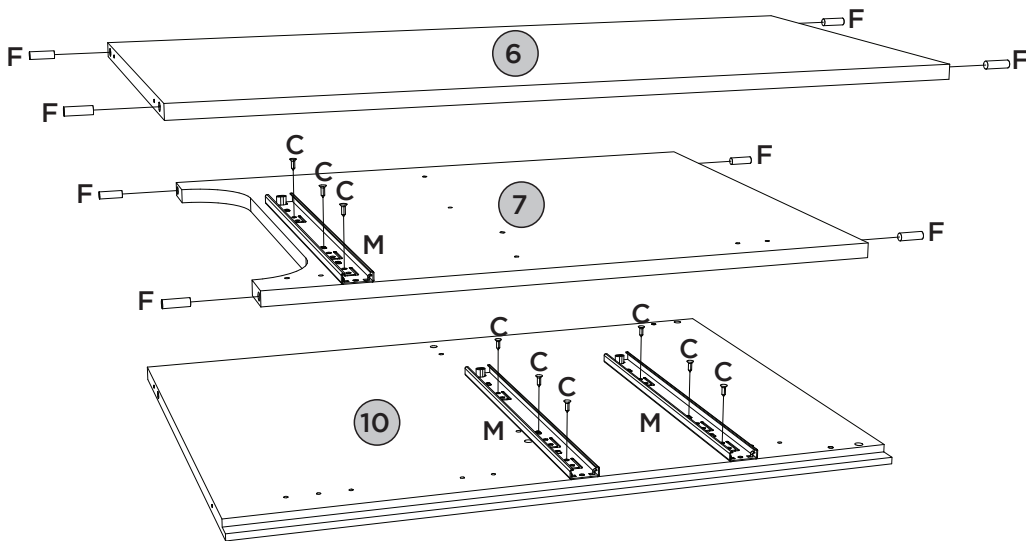

OPÇÃO 1 | OPCIÓN 1 | OPTION 1



PEÇAS REQUERIDAS

5	LATERAL ESQUERDA	x1
6	PRATELEIRA	x1
7	DIVISÃO	x1

ACESSÓRIOS REQUERIDOS

C		09
F		08
M		03
T		

FERRAMENTAS NECESSÁRIAS

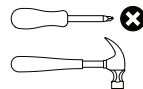



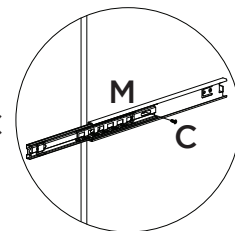
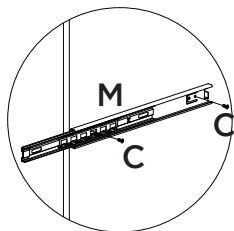
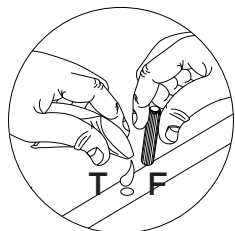
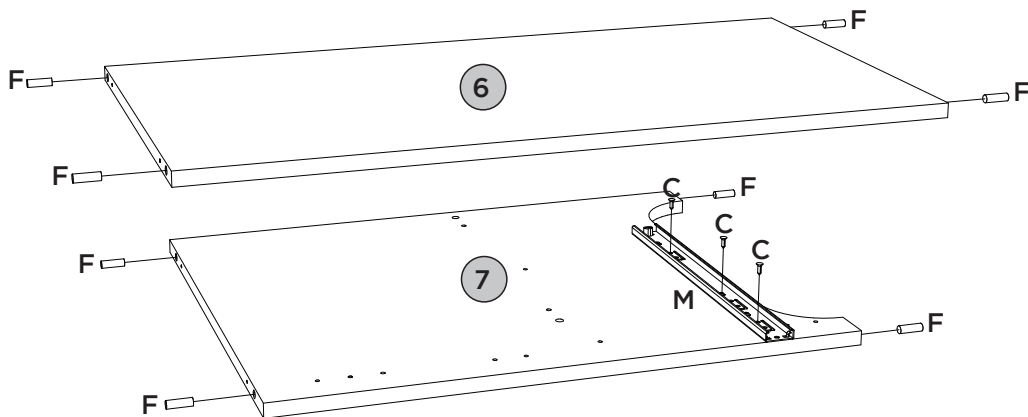
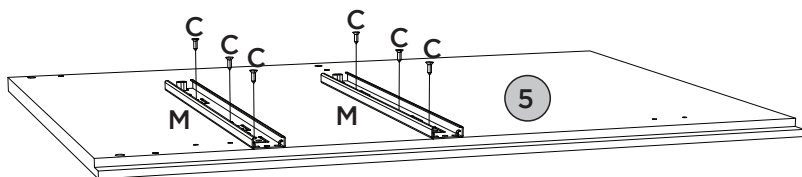

OPÇÃO 2 | OPCIÓN 2 | OPTION 2



PEÇAS REQUERIDAS

1	RODAPÉ FRONTAL	x1
2	RODAPÉ LATERAL	x2
3	RODAPÉ TRASEIRO	x1
8	TRAVESSA TRASEIRA	x1
9	TRAVESSA FRONTAL	x1
13	FRENTE DE GAVETA	x2
14	LADO DE GAVETA	x4
16	RIPA DE TRÁS	x2

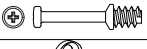
ACESSÓRIOS REQUERIDOS

C		04
F		24
J		08
L		04
T		

FERRAMENTAS NECESSÁRIAS

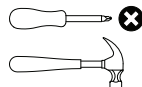

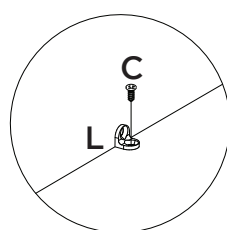
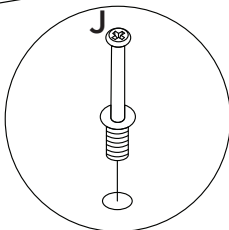
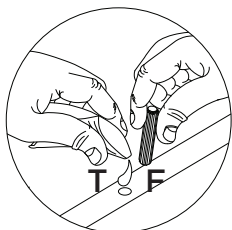
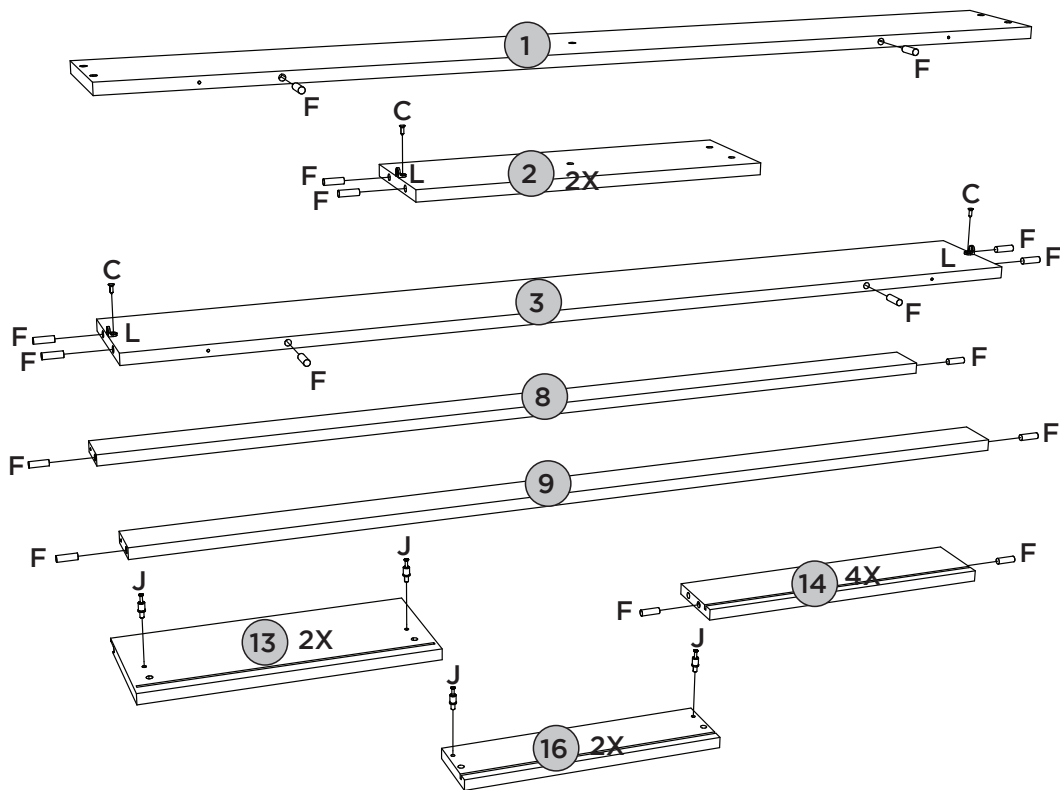

OPÇÃO 1 | OPCIÓN 1 | OPTION 1
OPÇÃO 2 | OPCIÓN 2 | OPTION 2



PEÇAS REQUERIDAS

17	PORTA ESQUERDA	x1
18	PORTA DIREITA	x1
19	PORTA MENOR	x1

ACESSÓRIOS REQUERIDOS

C		12
N		06

FERRAMENTAS NECESSÁRIAS

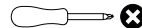

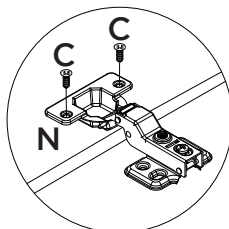
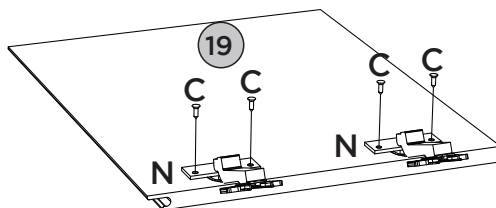
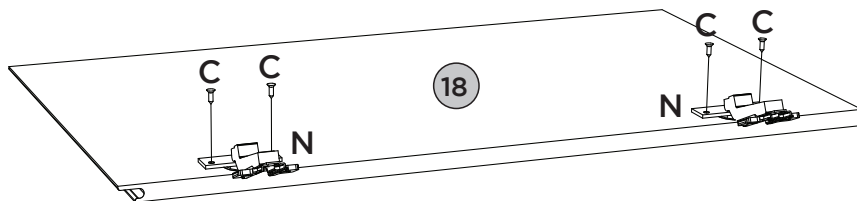
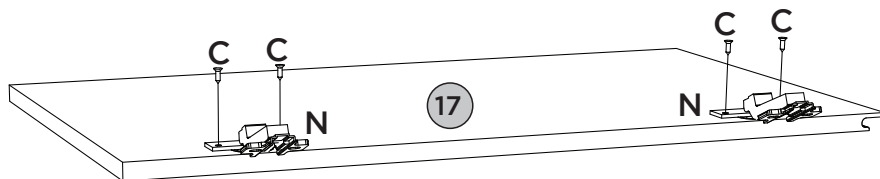

OPÇÃO 1 | OPCIÓN 1 | OPTION 1
OPÇÃO 2 | OPCIÓN 2 | OPTION 2



PEÇAS REQUERIDAS

1	RODAPÉ FRONTAL	x1
2	RODAPÉ LATERAL	x2
3	RODAPÉ TRASEIRO	x1

ACESSÓRIOS REQUERIDOS

C		04
G		06
R		06

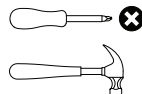
FERRAMENTAS NECESSÁRIAS

OPÇÃO 1 | OPCIÓN 1 | OPTION 1
 OPÇÃO 2 | OPCIÓN 2 | OPTION 2

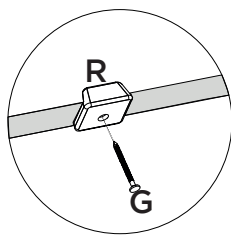
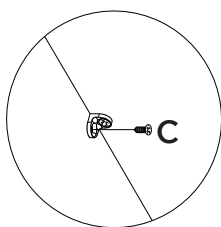
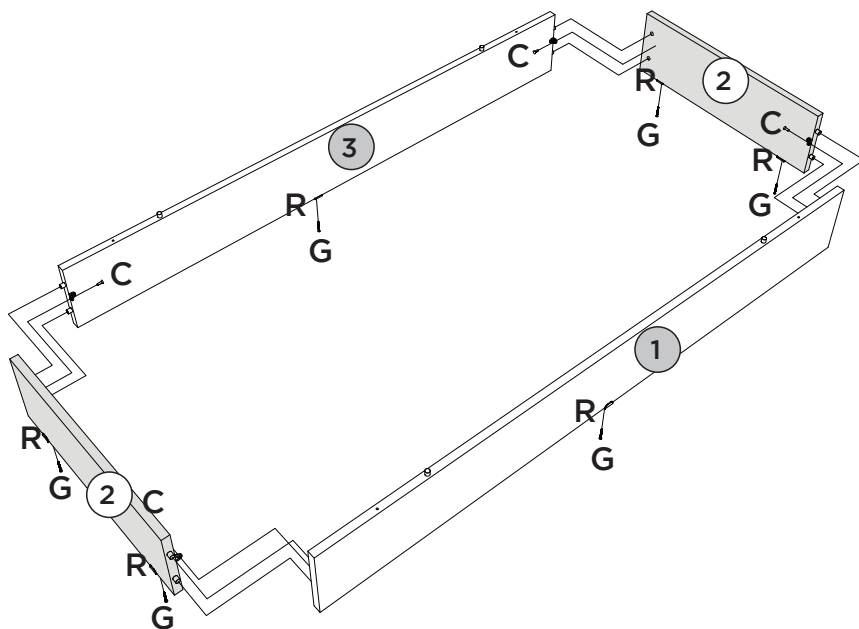

MONTAGEM 2 | MONTAJE 2 | ASSEMBLY 2

ITM/C656-

PEÇAS REQUERIDAS

4	BASE	x1
5	LATERAL ESQUERDA	x1
6	PRATELEIRA	x1
7	DIVISÃO	x1

ACESSÓRIOS REQUERIDOS

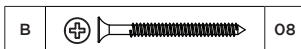

FERRAMENTAS NECESSÁRIAS

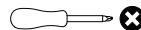

OPÇÃO 1 | OPCIÓN 1 | OPTION 1

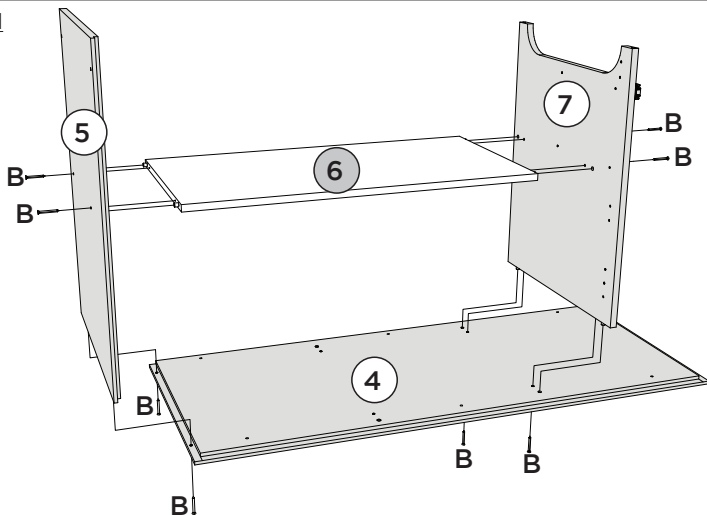

MONTAGEM 2 | MONTAJE 2 | ASSEMBLY 2

PEÇAS REQUERIDAS

4	BASE	x1
6	PRATELEIRA	x1
7	DIVISÃO	x1
10	LATERAL DIREITA	x1

ACESSÓRIOS REQUERIDOS

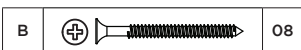

FERRAMENTAS NECESSÁRIAS

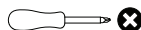

OPÇÃO 2 | OPCIÓN 2 | OPTION 2

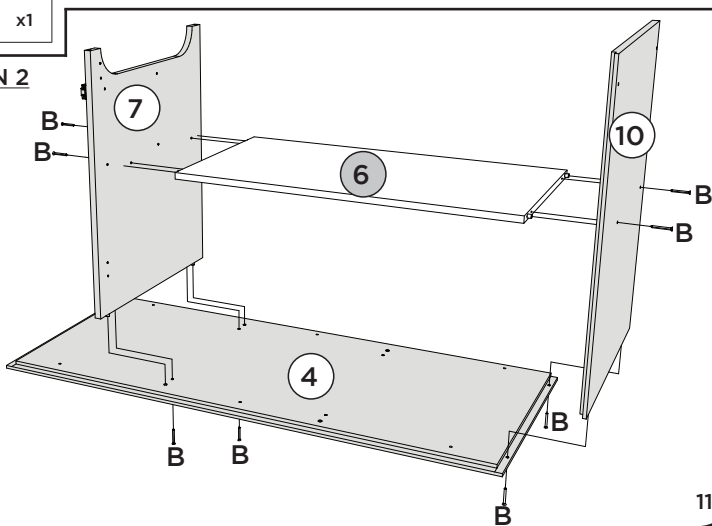



MONTAGEM 3 | MONTAJE 3 | ASSEMBLY 3

ITM/C656-

PEÇAS REQUERIDAS

8	TRAVESSA TRASEIRA	x1
9	TRAVESSA FRONTAL	x1
10	LATERAL DIREITA	x1

ACESSÓRIOS REQUERIDOS

B		06
C		03
M		01

FERRAMENTAS NECESSÁRIAS

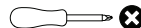

OPÇÃO 1 | OPCIÓN 1 | OPTION 1

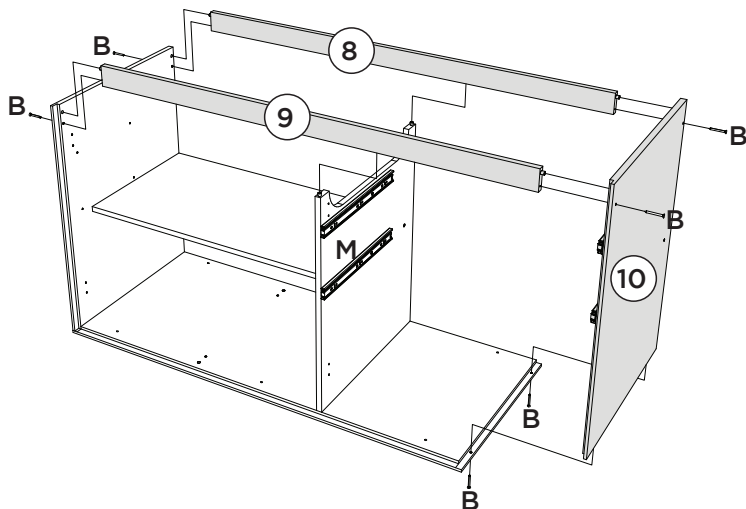
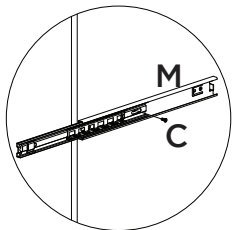
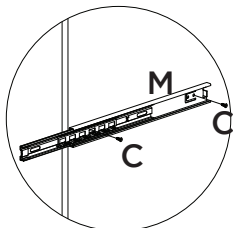



MONTAGEM 3 | MONTAJE 3 | ASSEMBLY 3

PEÇAS REQUERIDAS

5	LATERAL ESQUERDA	x1
8	TRAVESSA TRASEIRA	x1
9	TRAVESSA FRONTAL	x1

ACESSÓRIOS REQUERIDOS

B		06
C		03
M		01



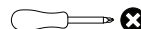

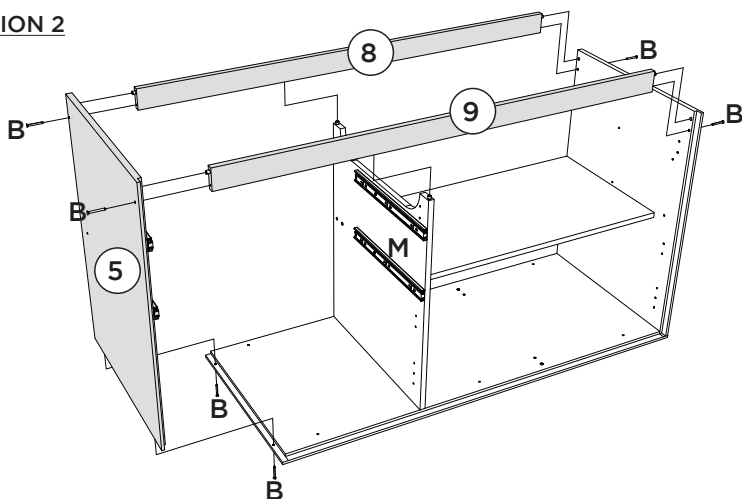
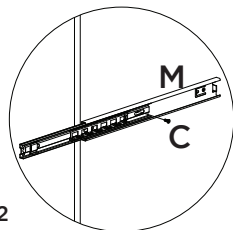
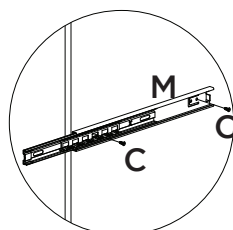

FERRAMENTAS NECESSÁRIAS



OPÇÃO 2 | OPCIÓN 2 | OPTION 2



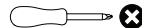
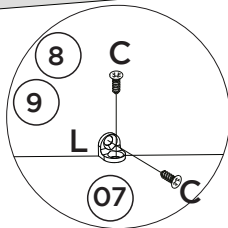
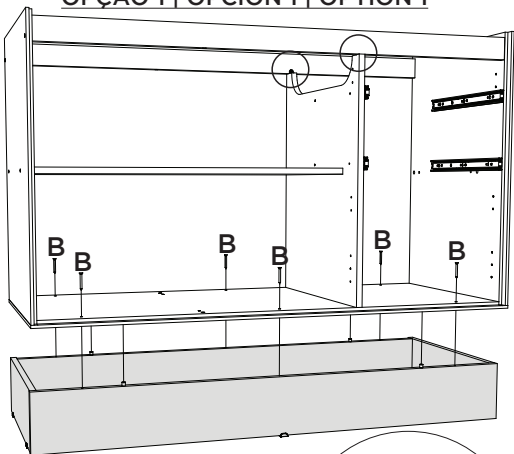
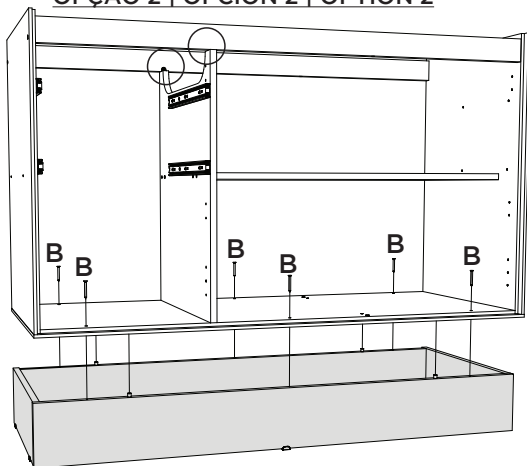

ACESSÓRIOS REQUERIDOS

B			06
C			04
L			02

FERRAMENTAS NECESSÁRIAS

OPÇÃO 1 | OPCIÓN 1 | OPTION 1

OPÇÃO 2 | OPCIÓN 2 | OPTION 2

MONTAGEM 5 | MONTAJE 5 | ASSEMBLY 5

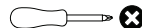
ACESSÓRIOS REQUERIDOS

B			04
---	---	---	----

FERRAMENTAS NECESSÁRIAS

Opção com Tampo (C922-133/214).

O Tampo é vendido separadamente.
As ferragens para fixação do Tampo constam no produto.

Opción con Tapa (C922-133/214).

La Tapa se vende por separado.
Los herrajes para la fijación de la tapa están incluidos en el producto.

Option with Top (C922-133/214)

The Top is sold separately.
The hardware for fixing the top is included with the product.

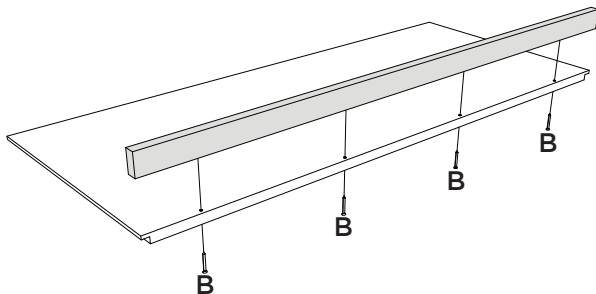

ACESSÓRIOS REQUERIDOS

C		12
L		06

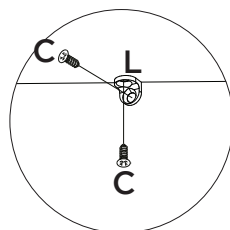
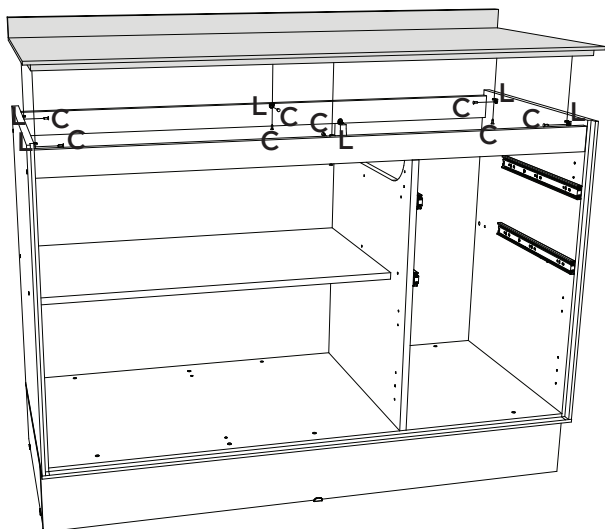
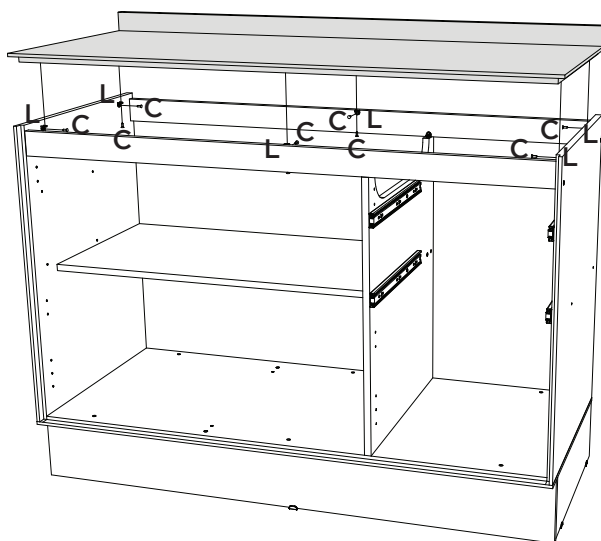

FERRAMENTAS NECESSÁRIAS

OPÇÃO 1 | OPCIÓN 1 | OPTION 1

OPÇÃO 2 | OPCIÓN 2 | OPTION 2

PEÇAS REQUERIDAS

11	FUNDO	x2
12	FUNDO LATERAL	x1

ACESSÓRIOS REQUERIDOS

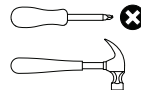
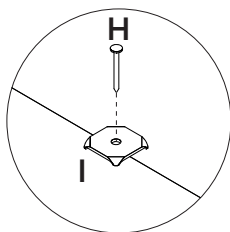
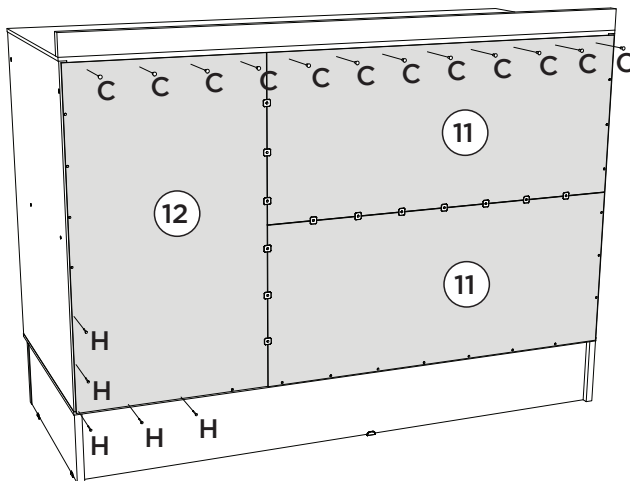
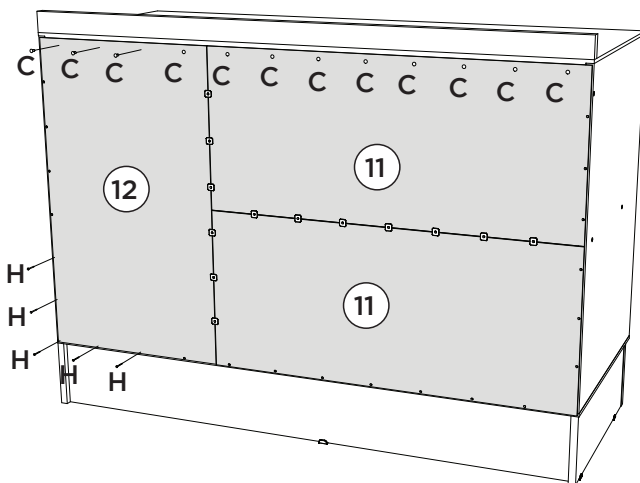
C		12
H		38
I		13

FERRAMENTAS NECESSÁRIAS

OPÇÃO 1 | OPCIÓN 1 | OPTION 1

OPÇÃO 2 | OPCIÓN 2 | OPTION 2





MONTAGEM 8 | MONTAJE 8 | ASSEMBLY 8

ITM/C656-

PEÇAS REQUERIDAS

13	FRENTE DE GAVETA	x2
14	LADO DE GAVETA	x4
15	FUNDO DE GAVETA	x2
16	RIPA DE TRÁS	x2

ACESSÓRIOS REQUERIDOS

C		12
K		08
M		04
T		

FERRAMENTAS NECESSÁRIAS



1º OPÇÃO 1 | OPCIÓN 1 | OPTION 1 OPÇÃO 2 | OPCIÓN 2 | OPTION 2

2X

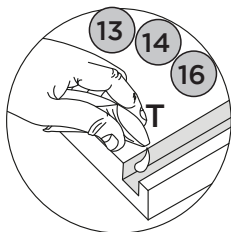
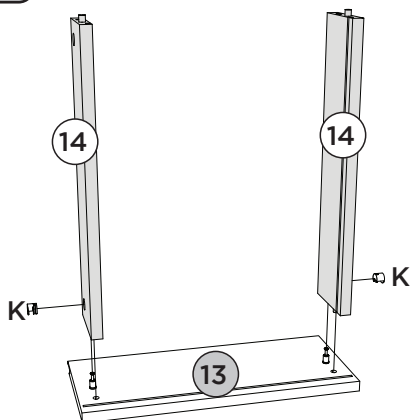

2º

2X

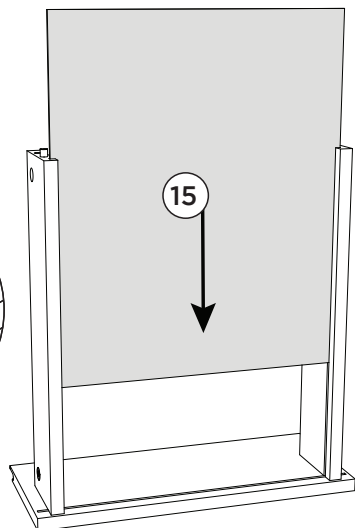
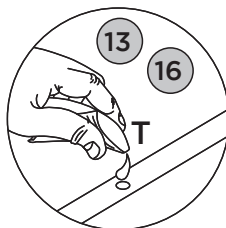

3º

2X

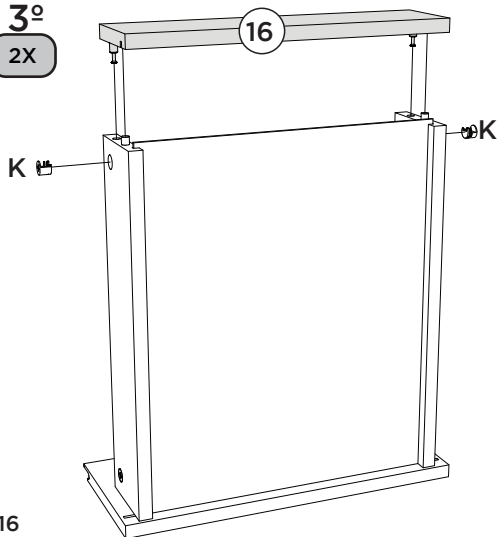

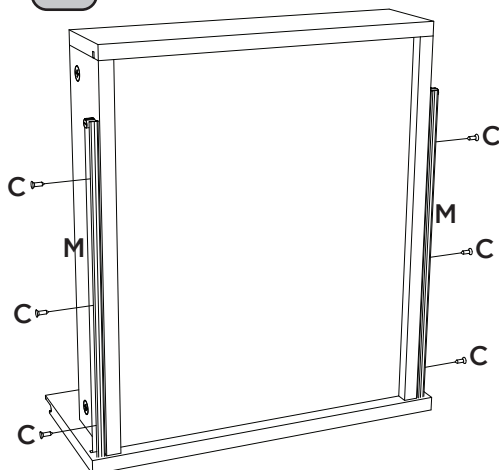

4º

2X



ACESSÓRIOS REQUERIDOS

S		01
U		04

OPÇÃO 1 | OPCIÓN 1 | OPTION 1

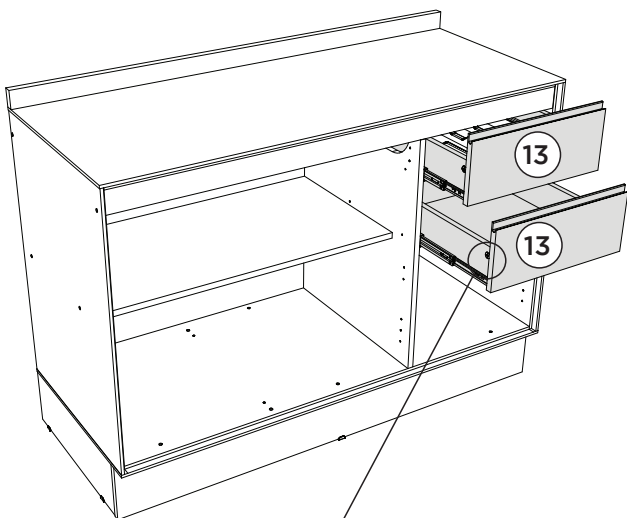

OPÇÃO 2 | OPCIÓN 2 | OPTION 2

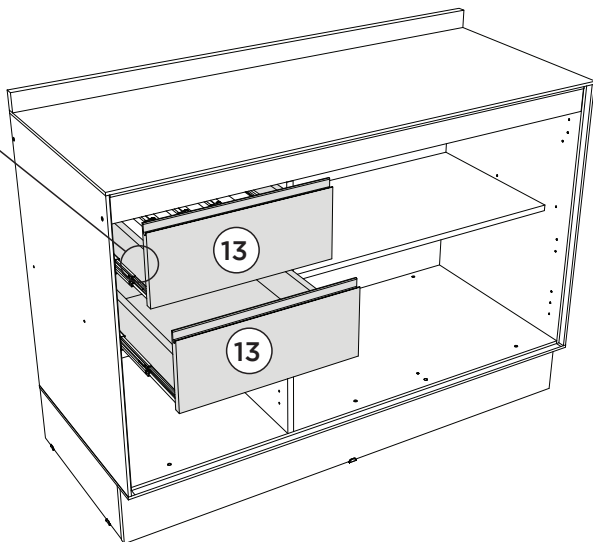

PEÇAS REQUERIDAS



17	PORTA ESQUERDA	x1
18	PORTA DIREITA	x1
19	PORTA MENOR	x1

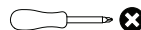
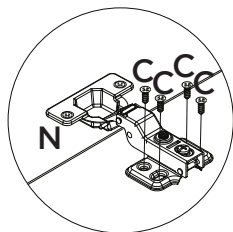
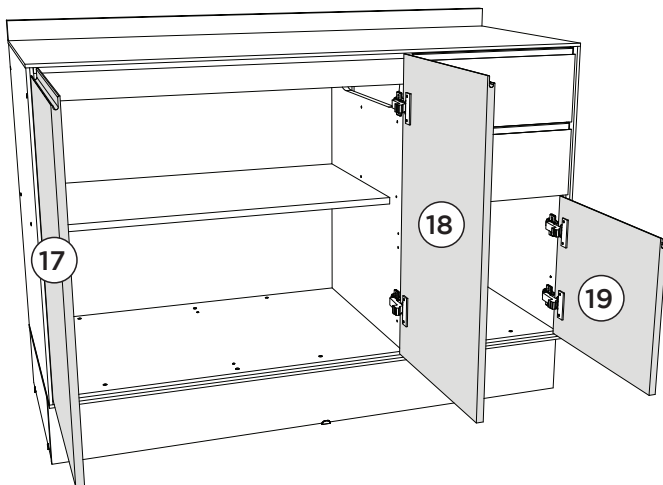
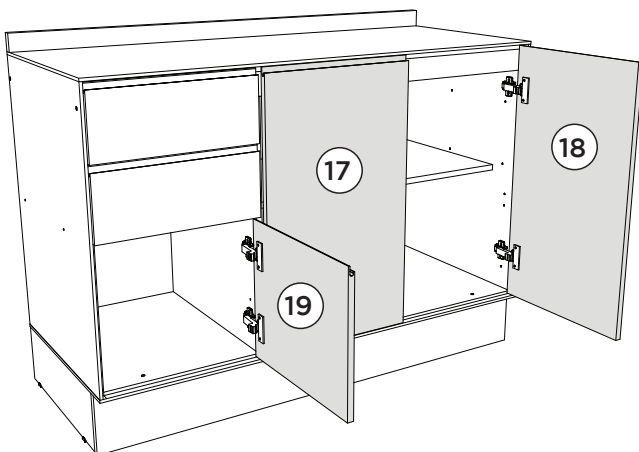

ACESSÓRIOS REQUERIDOS

C			24
---	--	--	----

FERRAMENTAS NECESSÁRIAS

OPÇÃO 1 | OPCIÓN 1 | OPTION 1

OPÇÃO 2 | OPCIÓN 2 | OPTION 2

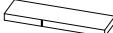
ACESSÓRIOS REQUERIDOS

A		02
C		04

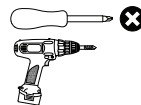
O		02
P		02
Q		02

FERRAMENTAS NECESSÁRIAS



Fixar móvel na Parede
Fijar el mueble a la pared
Secure the furniture to the wall



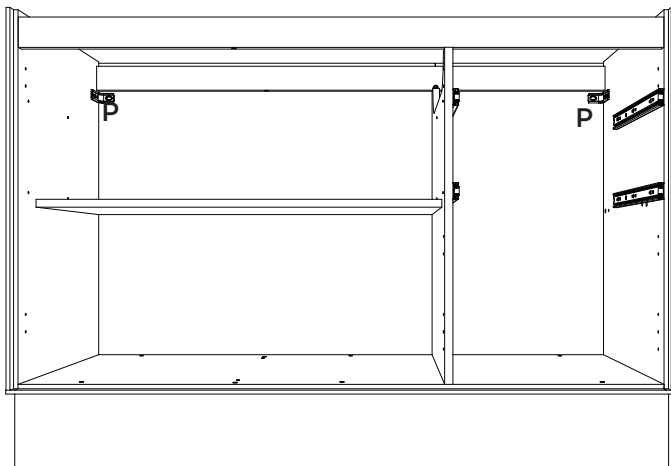
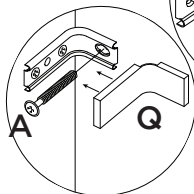
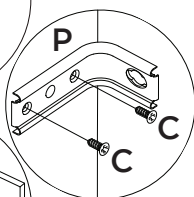
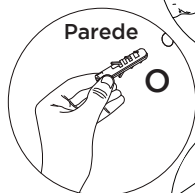
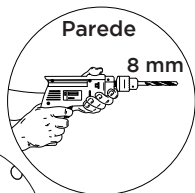

OPÇÃO 1 | OPCIÓN 1 | OPTION 1

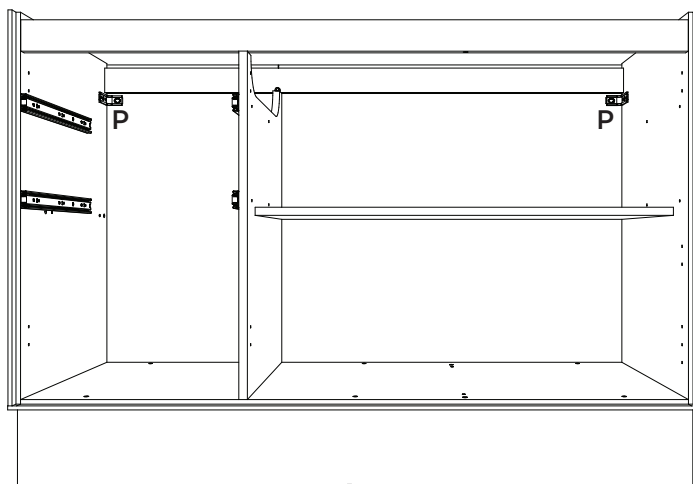

OPÇÃO 2 | OPCIÓN 2 | OPTION 2



ACESSÓRIOS REQUERIDOS

A			02
O			02

FERRAMENTAS NECESSÁRIAS

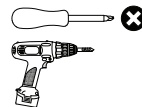

Opção Suspensa
Opción Suspendida
Suspended Option

OPÇÃO 1 | OPCIÓN 1 | OPTION 1

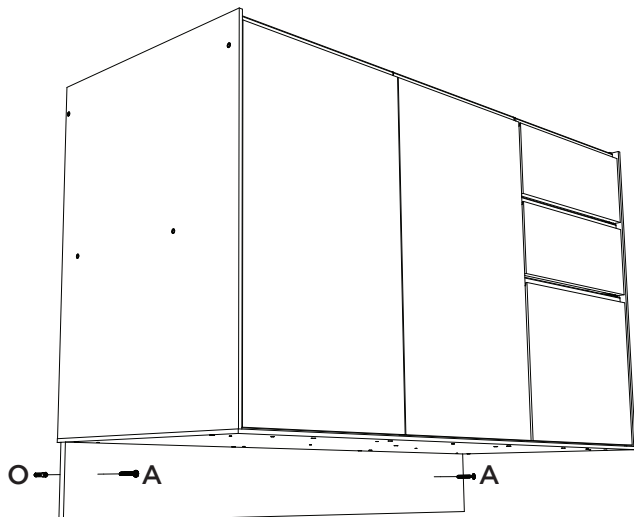

OPÇÃO 2 | OPCIÓN 2 | OPTION 2

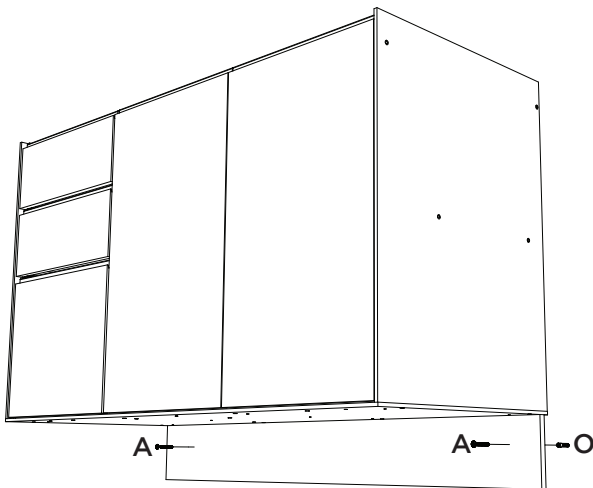
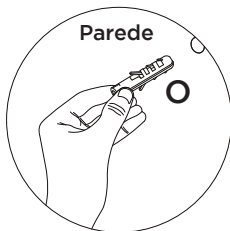
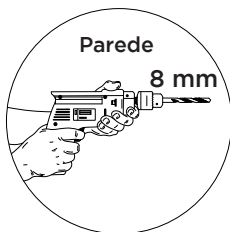



OBSERVAÇÃO:

Os parafusos (D e E) devem ser usados somente quando esse módulo for acoplado em outro módulo componível.

ACESSÓRIOS REQUERIDOS

D		04
E		04

FERRAMENTAS NECESSÁRIAS

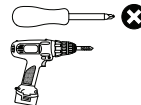

Observación:

Los tornillos (D y E) deben utilizarse únicamente cuando este módulo se acople a otro módulo componible.

Note:

Screws (D and E) should only be used when this module is attached to another modular unit.

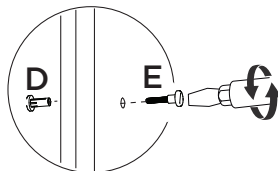

OPÇÃO 1 | OPCIÓN 1 | OPTION 1

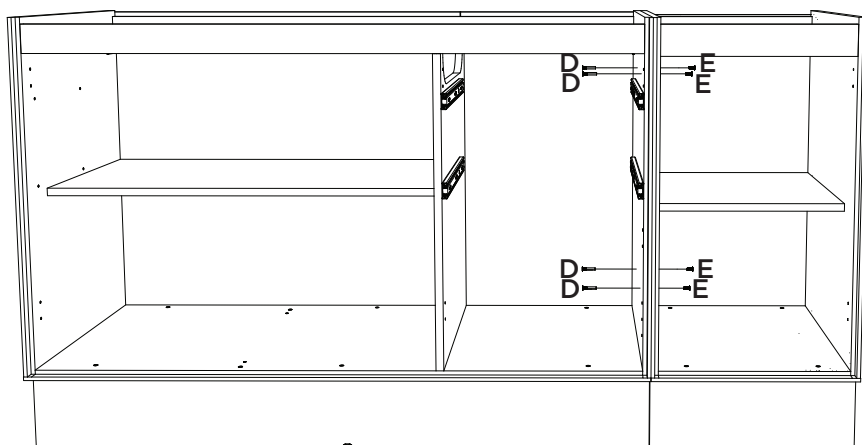

Balcão Pia 3 Portas 2 Gavetas

Módulo Componível

Fazer furação pas-sante assim que os módulos estiverem alinhados.

Realizar la perforación pasante una vez que los módulos estén alineados.

Drill a through hole once the modules are aligned.

OPÇÃO 2 | OPCIÓN 2 | OPTION 2

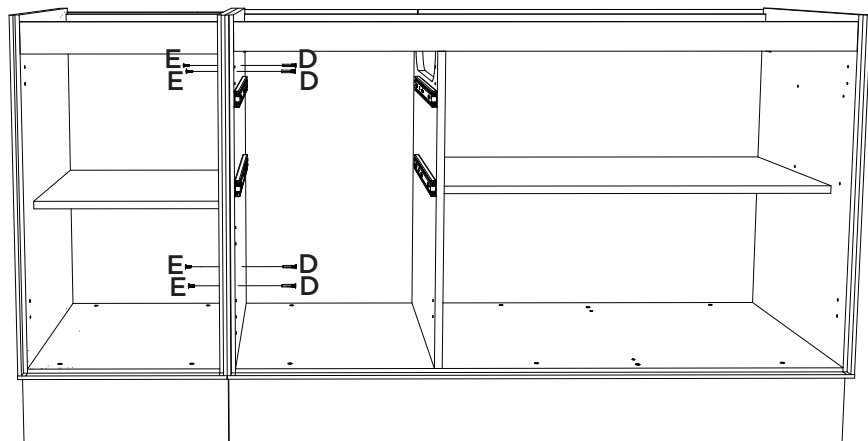

Módulo Componível

Balcão Pia 3 Portas 2 Gavetas

Opção com Pés
Opción con Patas
Option with Legs

FERRAMENTAS NECESSÁRIAS

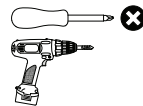

- O Kit Pés é vendido separadamente (O899-121).
As ferragens para fixação do Pés constam no Kit.**
- El kit de patas se vende por separado (O899-121).
Los herrajes para la fijación de las patas están incluidos en el kit.**
- The leg kit is sold separately (O899-121).
The hardware for attaching the legs is included in the kit.**

OPÇÃO 1 | OPCIÓN 1 | OPTION 1

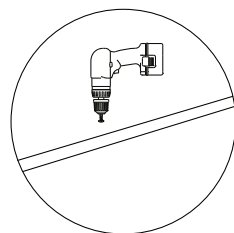
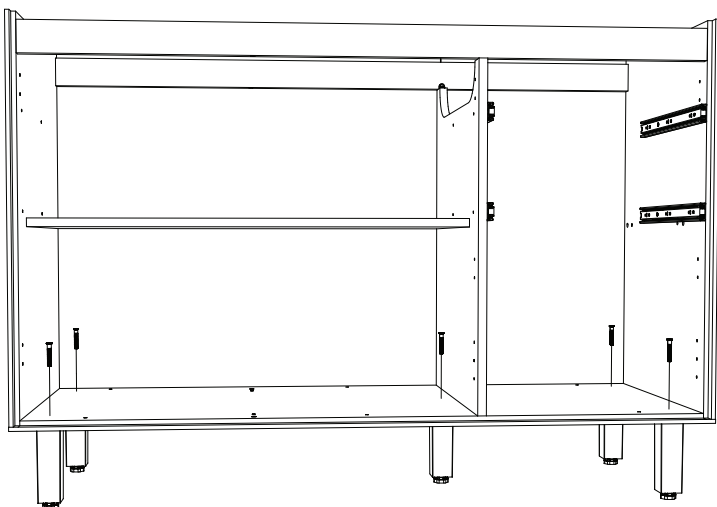

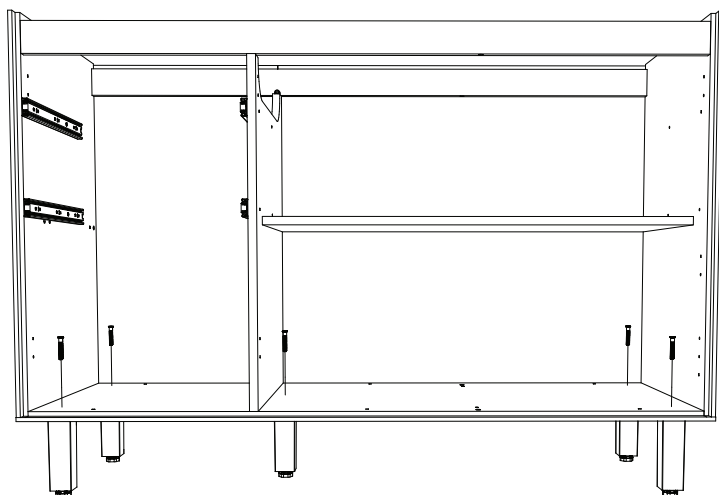

- Para fixar os pés, é necessário fazer a furação passante da Base.**
- Para fijar los pies, es necesario realizar la perforación pasante de la base.**
- To secure the feet, it is necessary to drill a through hole in the base.**

OPÇÃO 2 | OPCIÓN 2 | OPTION 2



ACESSÓRIOS REQUERIDOS

V		22
W		02
X	HENN	01

Pesos máximos recomendados com carga distribuída.
Peso máximo recomendado con la carga distribuída.
Recommended maximum weight with distributed load.

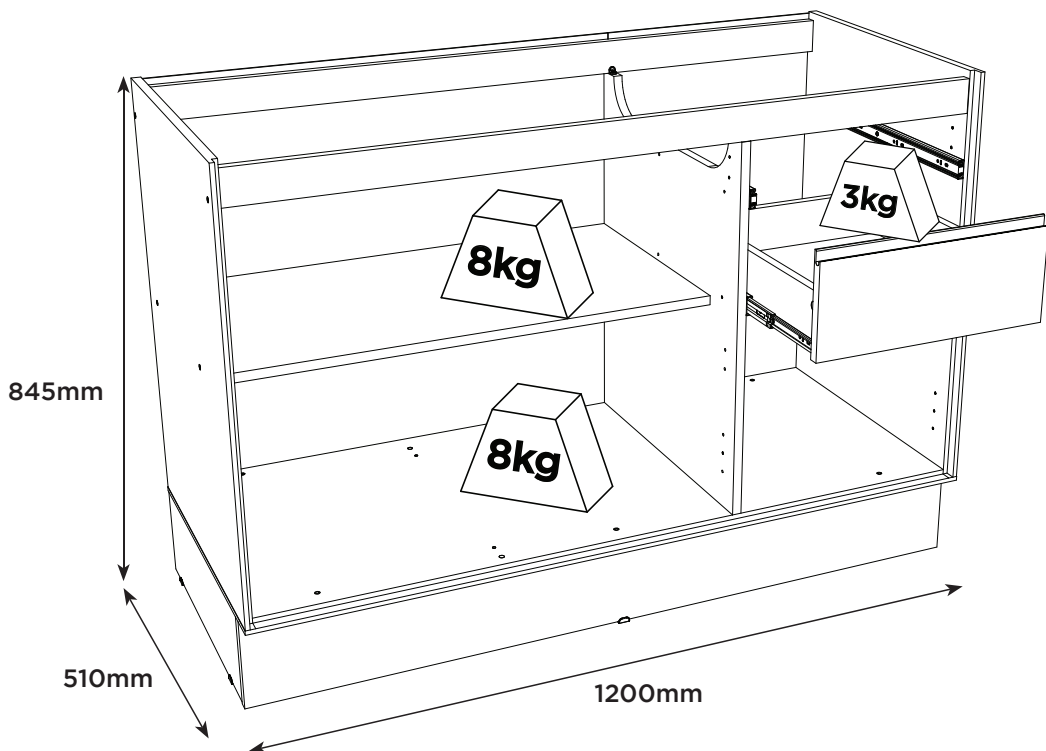

CORREÇÃO PERFEITA
CORRECCIÓN PERFECTA
PERFECT CORRECTION

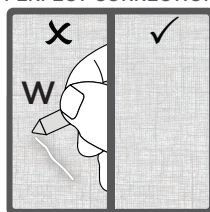
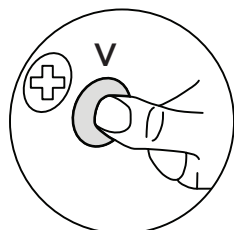



**PRODUTO CONCLUÍDO
PRODUCTO TERMINADO
FINISHED PRODUCT**

OPÇÃO 1 | OPCIÓN 1 | OPTION 1

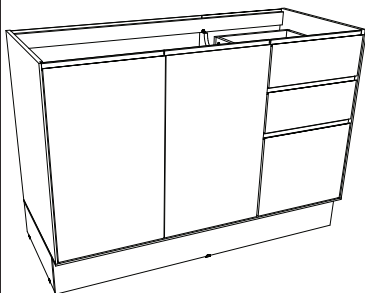

*Tampo não acompanha o produto
*La cubierta no está incluida con el producto.
*Top panel is not included with the product.

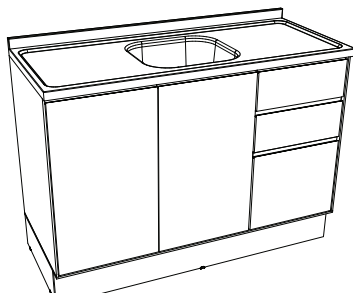
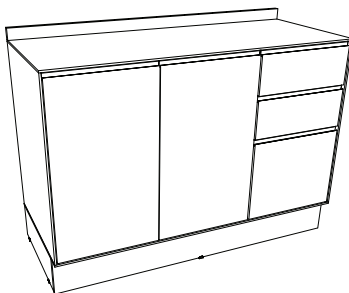

*Cuba não acompanha o produto
*El fregadero no está incluido con el producto.
*The sink is not included with the product.

OPÇÃO 2 | OPCIÓN 2 | OPTION 2

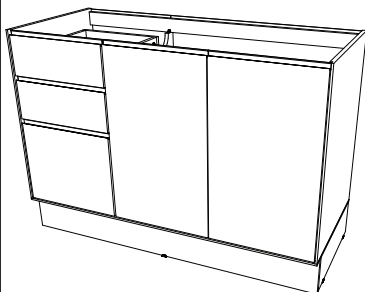

*Tampo não acompanha o produto
*La cubierta no está incluida con el producto.
*Top panel is not included with the product.

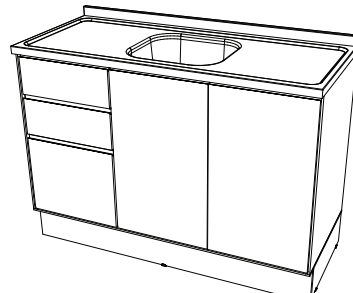
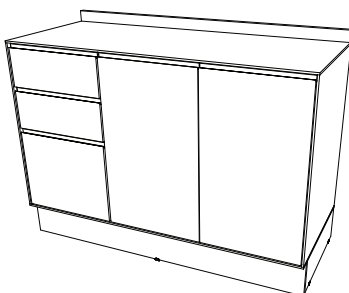

*Cuba não acompanha o produto
*El fregadero no está incluido con el producto.
*The sink is not included with the product.



HENNInd. e Com. de Móveis Henn
Mondai - SC - Brasil

☎ +55 49 3674.3500

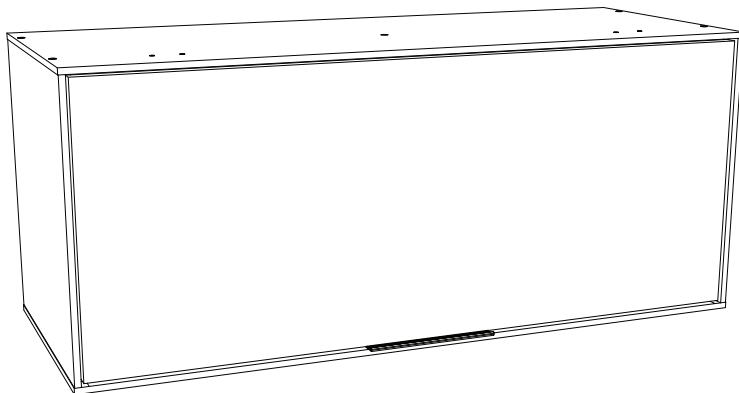
📷 📱 @moveishenn
www.henn.com.br**INSTRUÇÕES DE
MONTAGEM****INSTRUCCIONES DE MONTAJE
ASSEMBLY INSTRUCTIONS****AÉREO 01 PORTA BASCULANTE 800MM FINEZE | PUERTA AIR 01 INCLINABLE
800MM FINEZE | AIR 01 DOOR TILTING 800MM FINEZE****C657-133 Areia HP****AVISO**

Para limpeza de seu móvel, use uma franela seca ou umedecida, e não utilize produtos químicos que possam danificar seu produto.

SISTEMA DE MONTAGEM

O sistema de montagem dos produtos, funciona de acordo com a ordem crescente dos números indicados no desenho. Ex: 01, 02, 03, 04... até a conclusão da montagem.

ASSISTÊNCIA TÉCNICA

Para solicitação de Assistência Técnica você consumidor deverá entrar em contato com o Lojista o qual você realizou a compra deste produto e solicitar a assistência técnica das peças avariadas. A garantia abrange todas as peças, partes e componentes que eventualmente venham apresentar defeito de fabricação no prazo de 03 (três) meses, contando a partir da entrega do produto ao consumidor, mediante nota fiscal de compra. Se houver qualquer alteração na estrutura do produto ou ocorrer defeito por negligência do montador/consumidor em relação a instrução de montagem e manuseio, não será fornecido assistência técnica gratuita.

ADVERTENCIA

Para limpieza de su móvil, use una franela seca o húmeda, y no utilice productos químicos que puedan dañar su producto.

SISTEMA DE MONTAJE

El sistema de montaje de los productos funciona de acuerdo con el orden creciente de los números indicados en el dibujo. Ej.: 01, 02, 03, 04... hasta la conclusión del montaje.

ASISTENCIA TÉCNICA

Para solicitar Asistencia Técnica, el consumidor debe comunicarse con el Comercio que usted realizó la compra de este producto y solicita asistencia técnica para las partes dañadas. La garantía cubre todas las partes, piezas y componentes que eventualmente puedan presentar defecto de fabricación en el plazo de 03 (tres) meses, contados a partir de la entrega del producto al consumidor, mediante factura de compra. Si se produce algún cambio en la estructura del producto o se produce un defecto por negligencia del montador/consumidor en relación con las instrucciones de montaje y manipulación, no se prestará asistencia técnica gratuita.

NOTICE

To clean your furniture, use a dry or wet cloth, and do not use chemicals that may damage your product.









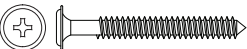

ASSEMBLY SYSTEM

The products' assembly system works according to the increasing order of the indicated numbers. For example: 01, 02, 03, 04 ... to the end of the assembly.

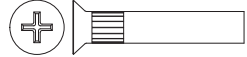
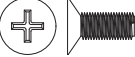
TECHNICAL ASSISTANCE

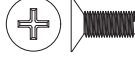
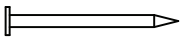
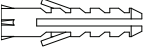
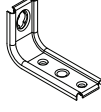
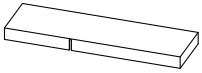
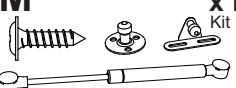
To request Technical Assistance, the consumer must contact the retailer from whom you purchased this product and request technical assistance for the damaged parts. The warranty covers all parts, parts and components that may eventually present a manufacturing defect within a period of 03 (three) months, counting from the delivery of the product to the consumer, by means of a purchase invoice. If there is any change in the structure of the product or defect occurs due to negligence of the assembler/consumer in relation to the assembly and handling instruction, free technical assistance will not be provided.

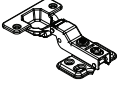
ACESSÓRIOS | ACCESORIOS | ACCESSORIES

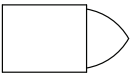
<p>A x2</p>  <p>Parafuso 5,0x50mm FLA.</p>	<p>B x8</p>  <p>Parafuso 3,5x40mm CHT.</p>	<p>C x12</p>  <p>Parafuso 4,0x14mm CHT.</p>	<p>D x2</p>  <p>Parafuso 3,5x12mm CHT.</p>
<p>E x4</p>  <p>Parafuso União Fêmea 27mm CHT</p>	<p>F x4</p>  <p>Parafuso União Macho 12mm CHT</p>	<p>G x4</p>  <p>Parafuso União Fêmea 15mm CHT</p>	<p>H x4</p>  <p>Parafuso União Macho 11mm CHT</p>
<p>I x22</p>  <p>Prego 10x10mm</p>	<p>J x2</p>  <p>Bucha Plástica 8mm</p>	<p>K x2</p>  <p>Suporte de Fixação</p>	<p>L x2</p>  <p>Proteção Cantoneira</p>
<p>M x1</p>  <p>Kit Pistão a Gás 60N</p>	<p>N x1</p>  <p>Perfil Puxador RX014 150mm</p>	<p>O x2</p>  <p>Dobradiças 35mm Pop Alta + Calço Fixo</p>	<p>P x1</p>  <p>Etiqueta Resinada Henn</p>
<p>Q x8</p>  <p>Adesivo Tapa Parafuso 10mm</p>	<p>R x2</p>  <p>Giz de Correção</p>		

PARAFUSOS EM ESCALA 1:1 | TORNILLOS A ESCALA 1:1 | 1:1 SCALE SCREWS

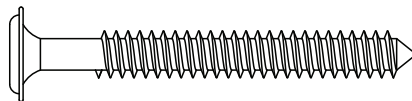
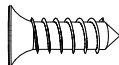
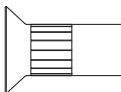
A**B****C****D****E****F****G****H**

LISTA DE PEÇAS | LISTA DE PIEZAS | LIST OF PIECES

Item	Caixa Caja Box	Qty Ctd Qty	Descrição Descripción Description	Dimensões (mm) Dimensiones (mm)		
				Comprimento Largo Length	Largura Ancho Width	Espessura Grosor Thickness
1	1/1	1	BASE BASE BASE	800	312	15
2	1/1	2	LATERAL DIREITA ESQUERDA LATERAL DERECHA IZQUIERDA RIGHT LEFT SIDE	323	312	15
3	1/1	1	TAMPO TAPA TOP	800	312	15
4	1/1	1	FUNDO FONDO BOTTOM	793	331	3
5	1/1	1	PORTA PUERTA DOOR	779	317	15

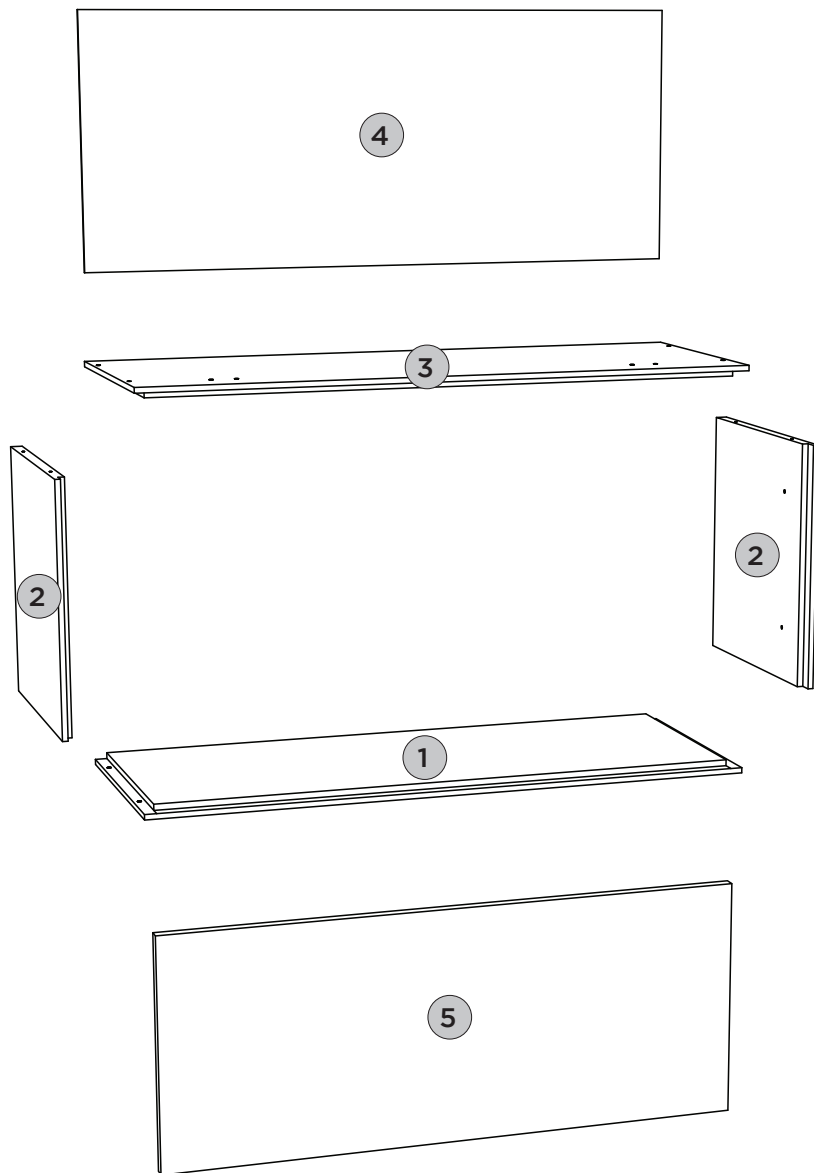

REQUISITOS PARA MONTAGEM

REQUISITOS PARA LA MONTAJE | ASSEMBLY REQUIREMENTS.

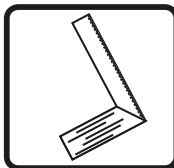
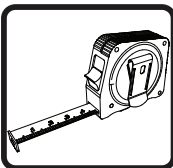
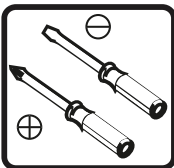
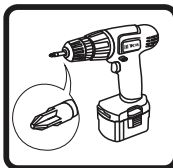

Imagens meramente ilustrativas, não acompanha o produto.







Imágenes ilustrativas, no incluidas con el producto.

Illustrative images, not included with the product.

PEÇAS REQUERIDAS

5	PORTA	x1
---	-------	----

ACESSÓRIOS REQUERIDOS

C	 	04
D	 	02
N		01
O		02

FERRAMENTAS NECESSÁRIAS

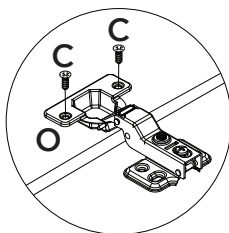
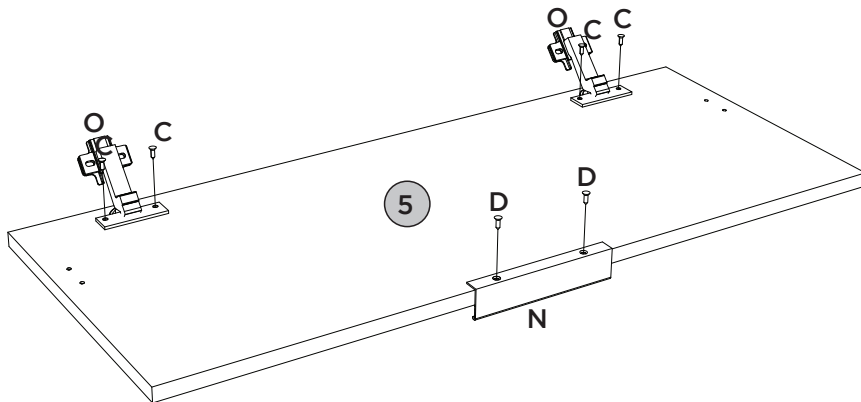
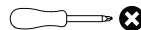

PEÇAS REQUERIDAS

1	BASE	x1
2	LATERAL DIREITA ESQUERDA	x2
3	TAMPO	x1

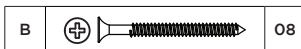
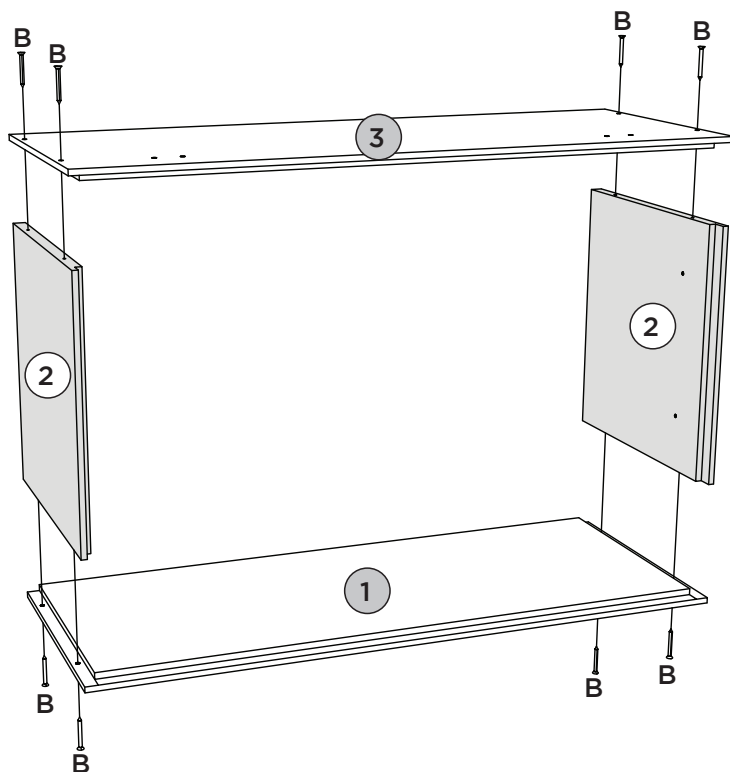
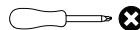
ACESSÓRIOS REQUERIDOS

FERRAMENTAS NECESSÁRIAS

PEÇAS REQUERIDAS

4	FUNDO	x1
---	-------	----

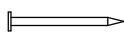
ACESSÓRIOS REQUERIDOS

1		22
---	---	----



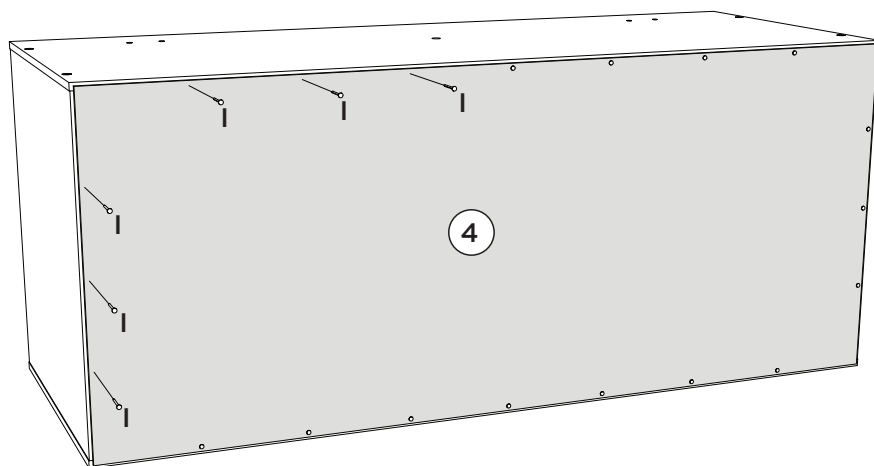
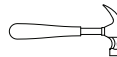

FERRAMENTAS NECESSÁRIAS



PEÇAS REQUERIDAS

5	PORTA	x1
---	-------	----

ACESSÓRIOS REQUERIDOS

C		04
G		04
H		04
M		01

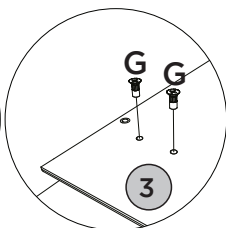
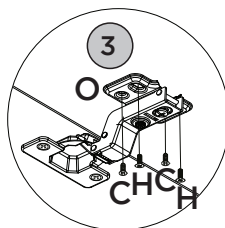
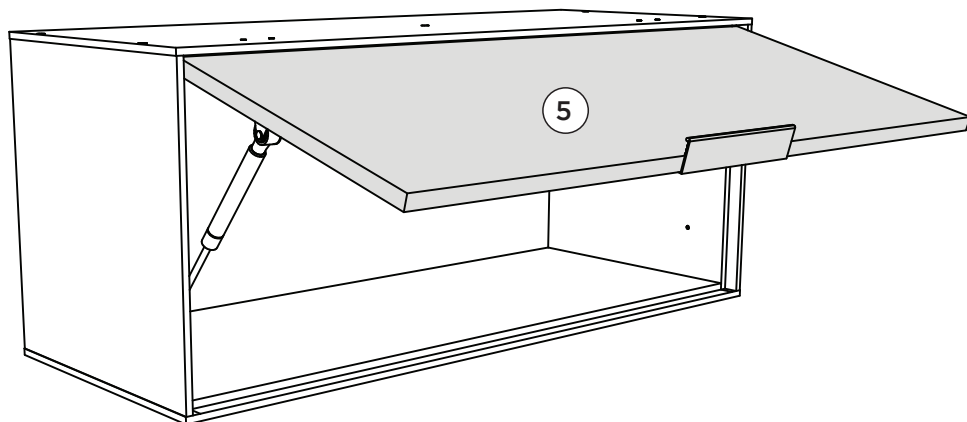
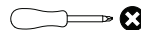
FERRAMENTAS NECESSÁRIAS

Para instalar o pistão, remova as tampinhas de proteção, posicione o pistão no local indicado e, em seguida, recoloque as tampinhas para garantir a fixação correta.

Para instalar el pistón, retire las tapas de protección, coloque el pistón en el lugar indicado y luego vuelva a colocar las tapas para garantizar una fijación correcta.

To install the piston, remove the protective caps, position the piston in the designated place, and then reinsert the caps to ensure proper fastening.

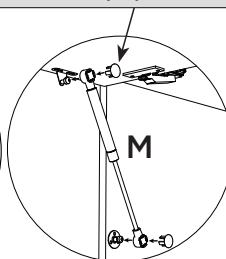
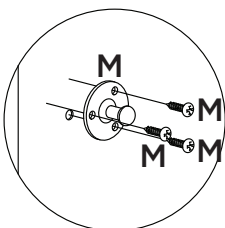
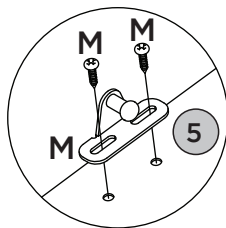

ACESSÓRIOS REQUERIDOS

A		02	J		02
C		04	K		02
			L		02

FERRAMENTAS NECESSÁRIAS

Fixar móvel na Parede
Fijar el mueble a la pared
Secure the furniture to the wall

Parede

8 mm

Parede

J

K

C

C

L



MONTAGEM 5 | MONTAJE 5 | ASSEMBLY 5

ACESSÓRIOS REQUERIDOS

E		04	F		04
---	--	----	---	--	----

FERRAMENTAS NECESSÁRIAS

OBSERVAÇÃO:

Os parafusos (E e F) devem ser usados somente quando esse módulo for acoplado em outro módulo componível.

Observación:

Los tornillos (E y F) deben utilizarse únicamente cuando este módulo se acople a otro módulo componible.

Note:

Screws (E and F) should only be used when this module is attached to another modular unit.

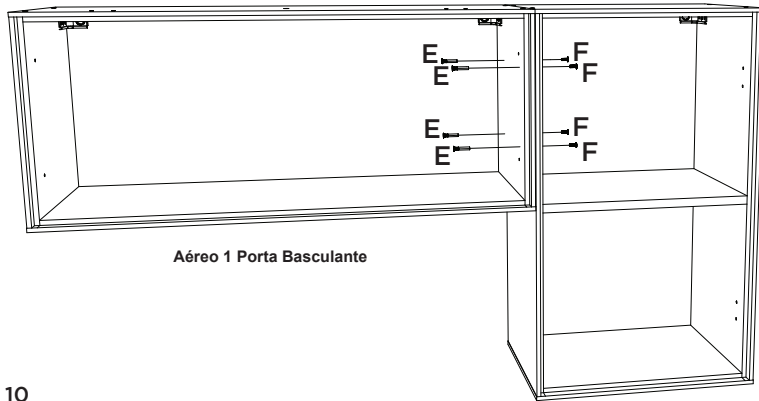

Aéreo 1 Porta Basculante

Módulo Componível

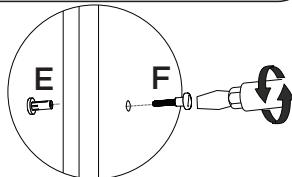



Fazer furação passante assim que os módulos estiverem alinhados.

Realizar la perforación passante una vez que los módulos estén alineados.

Drill a through hole once the modules are aligned.

ACESSÓRIOS REQUERIDOS

P	HENN	01
Q		08
R		02

**Pesos máximos recomendados com carga distribuída.
 Peso máximo recomendado con la carga distribuída.
 Recommended maximum weight with distributed load.**

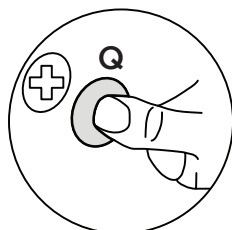
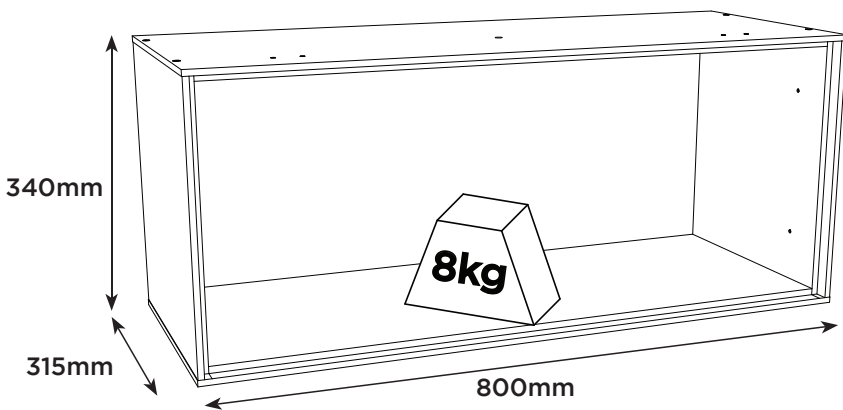

**CORREÇÃO PERFEITA
 CORRECCIÓN PERFECTA
 PERFECT CORRECTION**

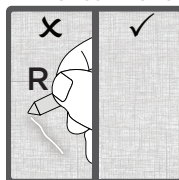

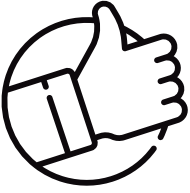

PRODUTO CONCLUÍDO
PRODUCTO TERMINADO
FINISHED PRODUCT

