

neshher

ARMÁRIO AÉREO 2 PORTAS NESHER SIMONE MENDES 120CM 100% MDF

NESHER SIMONE MENDES WALL CABINET W/ 2 DOORS 120 CM 100% MDF
ARMARIO COLGANTE CON 2 PUERTA NESHER SIMONE MENDES DE 120 CM 100 % MDF



A marca da gestão florestal responsável
The mark of responsible forest management
La marca de la gestión forestal responsable
FSC • C168299

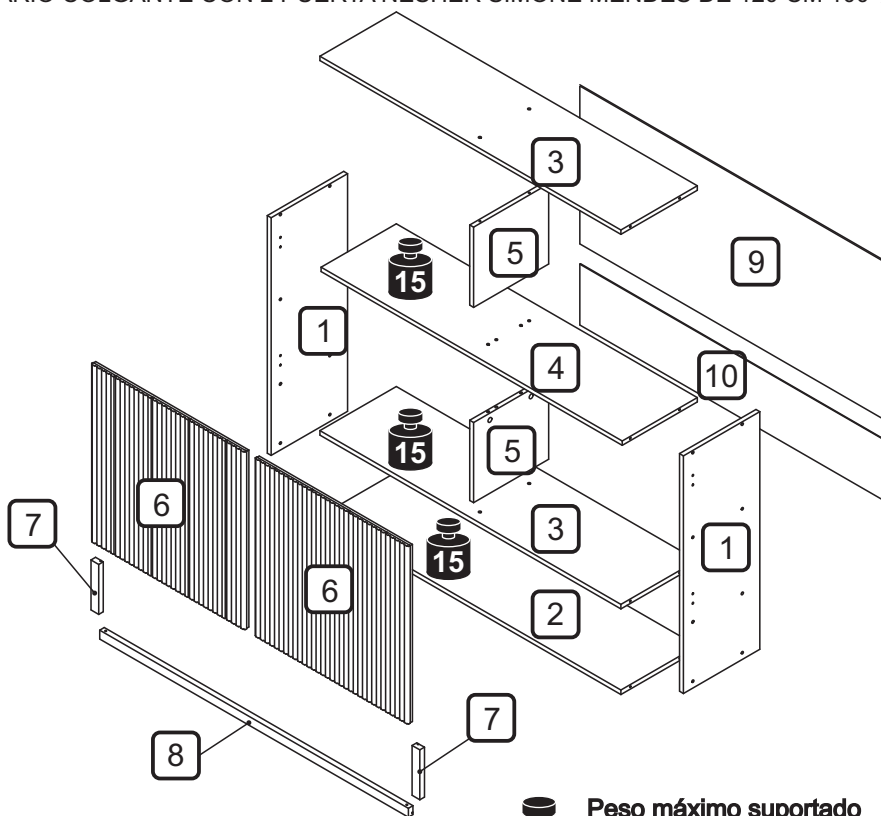
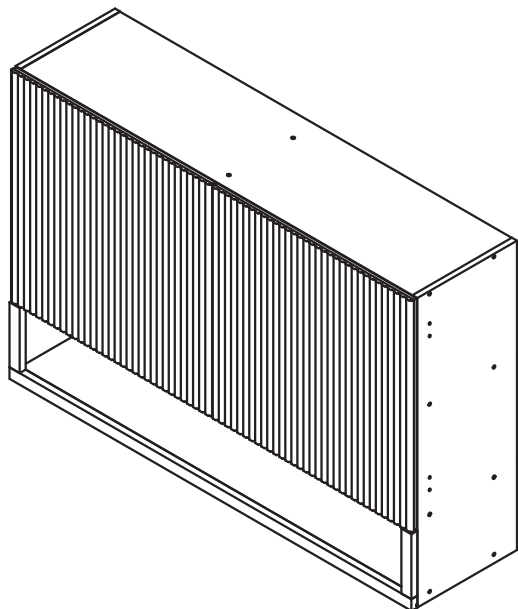

Peso máximo suportado
Maximum weight supported
Peso máximo suportado



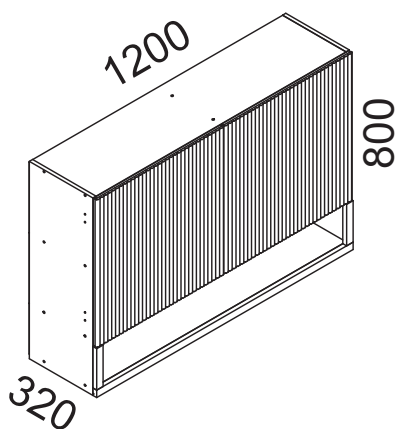



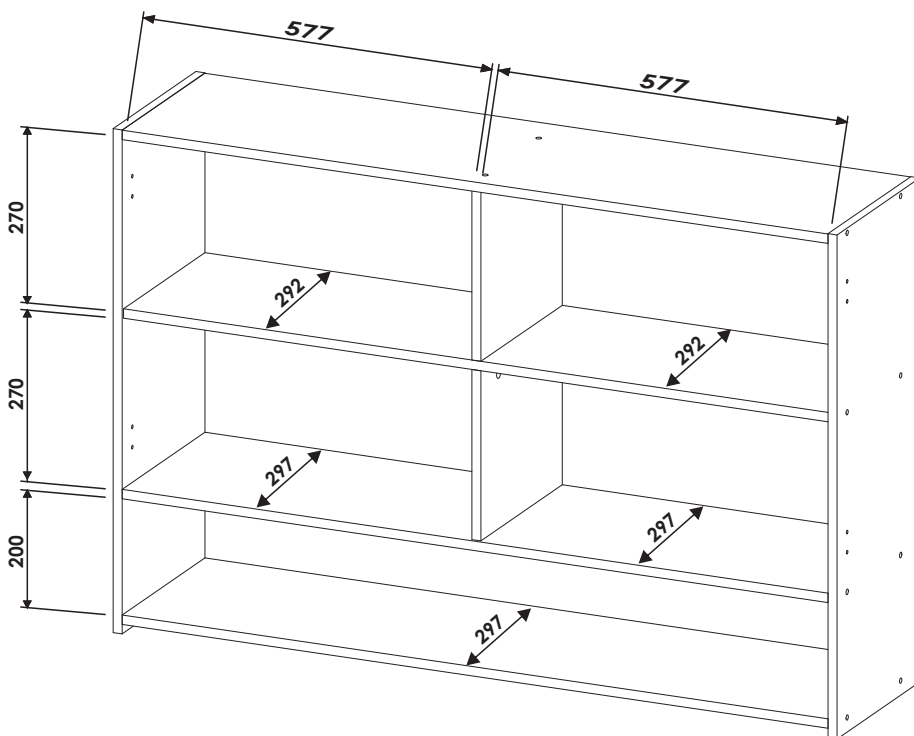

DIMENSÕES MÁXIMAS DO PRODUTO MONTADO
MAXIMUM DIMENSIONS OF THE ASSEMBLED PRODUCT
DIMENSIONES MÁXIMAS DEL PRODUCTO MONTADO

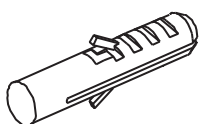
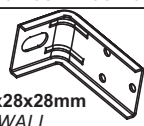
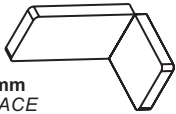

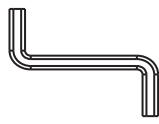
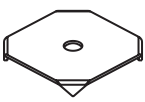
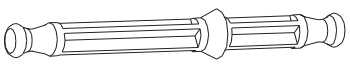
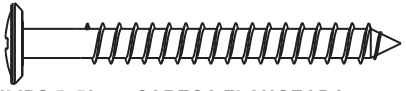
DIMENSÕES DOS ESPAÇOS INTERNOS (MEDIDAS EM MILÍMETROS)
DIMENSIONS OF INTERNAL SPACES (MEASUREMENTS IN MILLIMETERS)
DIMENSIONES DEL ESPACIO INTERNO (MEDIDAS EN MILÍMETROS)

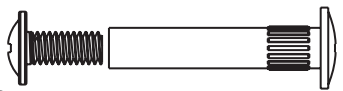
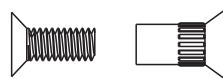
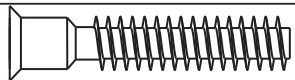
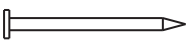

CÓDIGO CODE CÓDIGO	CARVALHO-GREIGE CARVALHO-GREIGE CARVALHO-GREIGE	DESCRIÇÃO DESCRIPTION DESCRIPCIÓN	MAT. PRIMA RAW MATERIAL MATERIA PRIMA	QUANT QTY CANT	COMP MEASUREMENTS MEDICIONES		
1	403562	LATERAL DIREITA/ESQUERDA / RIGHT_LEFT SIDE / LATERAL DERECHO_IZQUIERDO	MDF	2	800	297	15
2	403563	BASE / BASE / BASE	MDF	1	1,170	297	15
3	403564	TAMPO-PRATELEIRA INFERIOR / TOP-SHELF LOWER / TAPA-ESTANTE INFERIOR	MDF	2	1,170	297	15
4	403565	PRATELEIRA CENTRAL / CENTER SHELF / ESTANTE CENTRAL	MDF	1	1,170	292	15
5	403566	DIVISÃO / DIVIDER / DIVISIÓN	MDF	2	270	292	15
6	403535	PORTA / DOOR / PUERTA	MDF	2	598	598	18
7	403479	MOLDURA LATERAL / SIDE MOLDING / MARCO LATERAL	MDF	2	168	30	18
8	403480	MOLDURA INFERIOR / LOWER MOLDING / MARCO INFERIOR	MDF	1	1,200	30	18
9	403462	FUNDO TRASEIRO / BACK PANEL / FONDO POSTERIOR	DURATREE	1	1,195	575	2.5
10	403463	FUNDO TRASEIRO / BACK PANEL / FONDO POSTERIOR	DURATREE	1	1,195	205	2.5

CÓDIGO/DESCRIÇÃO CODE/DESCRIPTION CÓDIGO/DESCRIPCIÓN	QUANTIDADE QUANTITY CANTIDAD	CÓDIGO/DESCRIÇÃO CODE/DESCRIPTION CÓDIGO/DESCRIPCIÓN	QUANTIDADE QUANTITY CANTIDAD
A8  DOBRADIÇA RETA SLOW MOTION COM CALÇO BAIXA CANECO 35mm - CÓDIGO 200162 35 mm SLOW-MOTION STRAIGHT OVERLAY HINGE WITH BASE PLATE - CODE 200162 BISAGRA DE CIERRE DERECHO LENTO BAJA CAZOLETA DE 35 mm CON CUÑA - CÓDIGO 200162	4	F2  BUCHA DE PAREDE PLÁSTICA DE 8mm 8mm PLASTIC WALL ANCHOR TACOS DE PARED PLASTIC DE 8mm	4
F5  CANTONEIRA METÁLICA PARA FIXAÇÃO NA PAREDE 54x28x28mm 54x28x28mm METAL CORNER BRACE FOR SECURING TO WALL CANTONERA METÁLICA PARA FIJACIÓN EN LA PARED 54x28x28mm	4	F6  CAPA PLÁSTICA PARA CANTONEIRA 55x30x30mm 55x30x30mm PLASTIC COVER FOR CORNER BRACE TAPA DE PLÁSTICO PARA ÂNGULO 55x30x30mm	4 NATURE NATURE NATURE
F7  CAVILHA DE MADEIRA 8x30mm 8x30mm WOODEN DOWEL PIN TARUGO DE MADERA 8x30mm	4	F9  CHAVE ZETA 4mm 4mm S-SHAPED HEX KEY LLAVE ZETA 4mm	1
F11  FIXADOR TRASEIRO METÁLICO 14x14mm 14x14mm METAL BACK PANEL FASTENER SUJETADOR METÁLICO DEL FONDO POSTERIOR 14x14mm	12	F12  HASTE DUPLA PARA MINIFIX CAM LOCK DOUBLE SCREW VÁSTAGO DOBLE PARA MINIFIX	2
F22  PARAFUSO PHILIPS 5x50mm CABEÇA FLANGEADA PHILIPS SCREW 5x50 mm FLANG HEAD TORNILLO PHILIPS 5x50 mm CABEZA CON BRIDA	4	F23  PARAFUSO PHILIPS 4x14mm CABEÇA PANELA PHILIPS SCREW 4x14 mm PAN HEAD TORNILLO PHILIPS 4x14 mm CABEZA ALOMADA	36
F25  PARAFUSO UNIÃO 28mm 28mm CONNECTOR SCREW TORNILLO DE UNIÃO 28mm	3	F26  PARAFUSO UNIÃO 17mm 17mm CONNECTOR SCREW TORNILLO DE UNIÃO 17mm	9
F28  PARAFUSO ALLEN S_PONTA 7x40mm CABEÇA CHATA ALLEN SCREW WITOUH TIP 7x40 mm FLAT HEAD TORNILLO ALLEN SIN PUNTA 7x40 mm CABEZA PLANA	22	F29  PREGO 10X10 COM CABEÇA 10x10 NAIL WITH HEAD CLAVO CON CABEZA DE 10x10	65
F31  SUPORTE ANGULAR PLÁSTICA 22x15x12mm 22x15x12mm PLASTIC ANGLE BRACKET ESCUADRA DE ANGULO PLASTIC 22x15x12mm	8 NATURE NATURE NATURE	F32  TAMBOR MINIFIX 15mm 15mm CAM LOCK NUT TAMBOR MINIFIX 15mm	5
F33  TAMPA PLÁSTICA MINIFIX 15mm 15mm PLASTIC CAM LOCK COVER CUBIERTA PLASTIC MINIFIX 15mm	4 NATURE NATURE NATURE	F34  TAPA FURO ADESIVO 12mm 12 mm ADHESIVE HOLE COVERS CUBRE ORIFICIOS ADHESIVO DE 12 mm	30 NATURE NATURE NATURE

Ferramentas para montagem e instalação / Tools for assembly and installation / Herramientas de montaje e instalación
 Não fornecidas / Not Provided / No Provisto



PARAFUSADEIRA
 POWER SCREWDRIVER
 DESTORNILLADOR



FURADEIRA
 DRILL
 TALADRO



NÍVEL
 LEVEL
 NIVEL



TRENA
 TAPE MEASURE
 CINTA METRICA



MARTELO
 HAMMER
 MARTILLO



CHAVE PHILIPS E FENDA
 PHILLIPS SCREWDRIVER
 LLAVE PHILIPS



MONTAGEM
 ASSEMBLY
 MONTAJE

PASSO 1

STEP 1

PASO 1

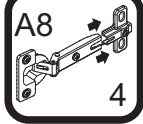
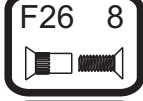
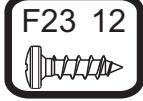

- 1 - Posicione as cantoneiras F5 na borda traseira das peças 1, e fixá-las com os parafusos F23 (4x14mm)
- 2 - Inserir as cavilhas F7 (8x30mm) nas peças 5
- 3 - Retirar o calço da dobradiça A8 e fixá-los nas peças 1, utilizando os parafusos de união F26 (17mm)

- 1 - Position corner braces F5 on the back edge of parts 1 and secure them with screws F23 (4x14 mm)
- 2 - Insert dowel pins F7 (8x30 mm) into parts 5
- 3 - Remove the shim from hinge A8 and attach them to pieces 1, using the F26 (17mm) joint screws.

- 1 - Coloque las cantoneras F5 en el borde posterior de las piezas 1 y fijelas con los tornillos F23 (4x14 mm)
- 2 - Inserte los tarugos F7 (8 x 30 mm) en las piezas 5
- 3 - Fije las cuñas A8 a las piezas 1 con los tornillos de unión F26 (17 mm)

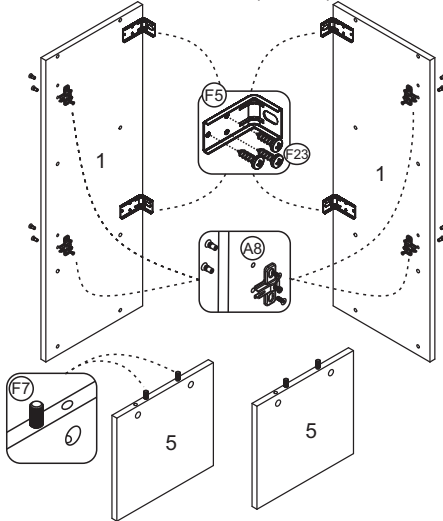

PASSO 3

STEP 3

PASO 3

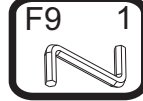
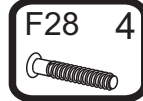
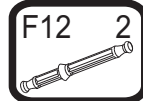

- 1 - Fixar as prateleira 4, nas laterais 1 com item F28 (7x40mm), utilizando chave zeta F9
- 2 - Inserir o acessório F12 na furação da prateleira 4, encaixar a peça 5 na furação da prateleira 4, inserir o acessório F32, utilizar uma chave de fenda para girar o tambor até travar

- 1 - Fix shelf 4 into sides 1 with item F28 (7x40 mm) using F9 shaped hex key
- 2 - Insert accessory F12 into the hole on the shelf 4, Fit part 5 into the hole on shelf 4, insert accessory F32, and use a screwdriver to turn the cam until it locks

- 1 - Fije los al estante 4 en la laterales 1 con el elemento F28 (7x40 mm). utilizando la llave zeta F9
- 2 - Insertar el accesorio F12 en el orificio de la estante 4, encajar la pieza 5 en el orificio de la estante 4, insertar el accesorio F32 y utilizar un destornillador para girar el tambor hasta que se trabé

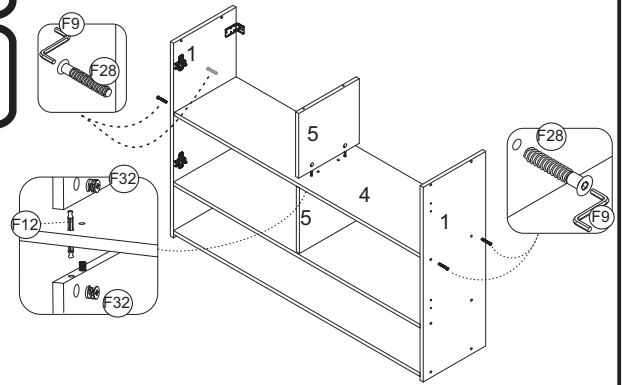

PASSO 2

STEP 2

PASO 2

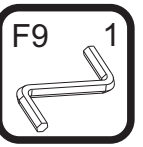

- 1 - Fixar as laterais 1 na base 2 com parafusos F28 (7x40mm), utilizando a chave zeta F9
- 2 - Fixar as peças 5 na prateleira 3 com parafusos F28 (7x40mm), utilizando a chave zeta F9
- 3 - Fixar as peças 1 na prateleira 3 com parafusos F28 (7x40mm), utilizando a chave zeta F9

- 1 - Fix the sides 1 to the base 2 with screws F28 (7x40mm), using the zeta F9 key
- 2 - Fix parts 5 on shelf 3 with screws F28 (7x40mm), using the zeta wrench F9
- 2 - Fix parts 1 on shelf 3 with screws F28 (7x40mm), using the zeta wrench F9

- 1 - Fijar los lados 1 a la base 2 con tornillos F28 (7x40mm), usando la tecla zeta F9
- 2 - Fijar las piezas 5 en el estante 3 con tornillos F28 (7x40mm), usando la llave zeta F9
- 3 - Fijar las piezas 1 en el estante 3 con tornillos F28 (7x40mm), usando la llave zeta F9

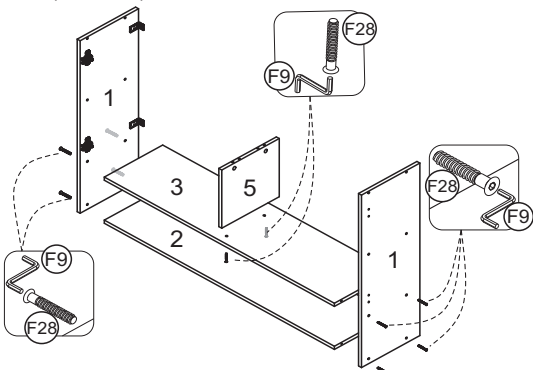

PASSO 4

STEP 4

PASO 4

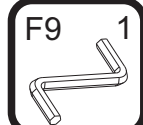

- 1 - Fixar o tampo 3 nas laterais 1 e na divisão 5, com parafusos F28 (7x40mm), utilizando a chave zeta F9

- 1 - Secure top 3 on the sides 1 and on divider 5, with screws F28 (7x40 mm), using S-shaped hex key F9

- 1 - Fije la tapa 3 a los laterales 1 y a la división 5, con tornillos F28 (7x40 mm), utilizando la llave de zeta F9

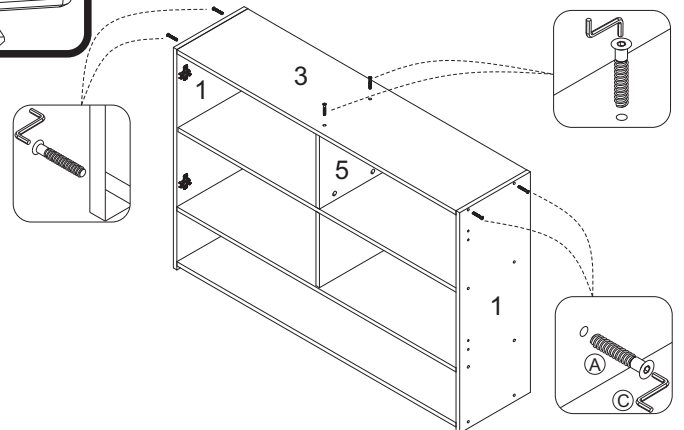

PASSO 5

STEP 5

PASO 5

F29 65



F11 12



- 1 - Alinhar a peça 9 e fixá-la com pregos F29 (10x10) na parte de cima e nas laterais, depois fixar a outra peça 10 com pregos F29 (10x10) na parte inferior e laterais
- 2 - Na junção entre as peças 9 e 10 utilizar os pregos F29 (10x10) com o fixador metálico F11

- 1 - Alinee la pieza 9 y fijela con clavos F29 (10x10) en la parte superior y en los laterales. Después fije la otra pieza 10 con clavos F29 (10x10) en la parte inferior y en los laterales.
- 2 - Para unir las piezas 9 y 10, utilice clavos F29 (10x10) con sujetador metálico F11

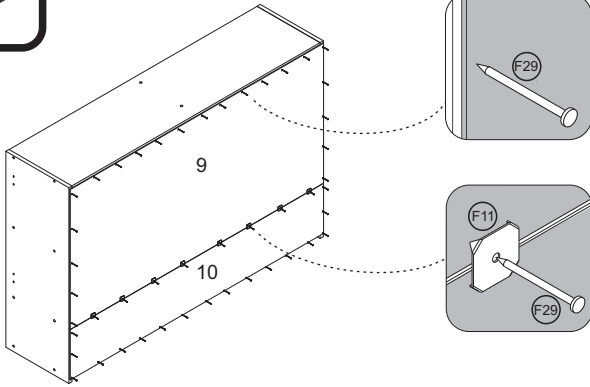

PASSO 7

STEP 7

PASO 7

F31 8



F23 16



- 1 - Fixar a moldura 8, e molduras laterais 7 com suporte angular F31 e parafuso F23 (4x14)

- 1 - Fix molding 8, side moldings 7 with angle bracket F31 and screw F23 (4x14)

- 1 - Fije el marco 10, los marcos laterales 7 con la escuadra de ángulo F31 y los tornillos F23(4x14 mm)

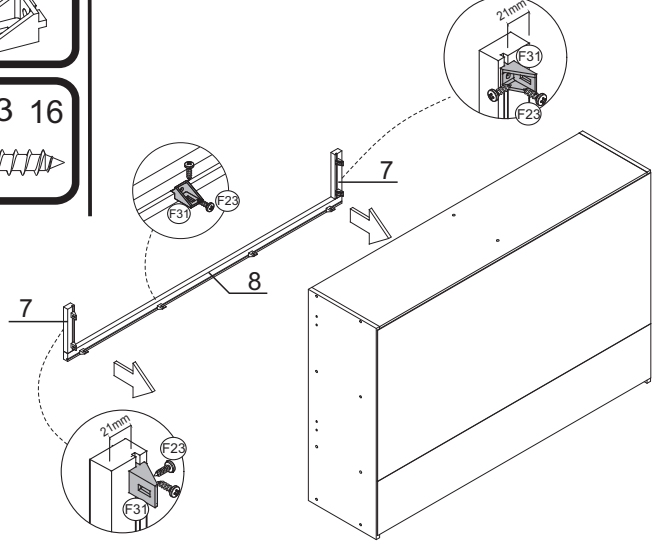

PASSO 6

STEP 6

PASO 6

F2 4



F22 4

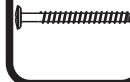

FIXAÇÃO NA PAREDE (ALVENARIA)

ATENÇÃO: Antes de fixar o armário na parede verifique se o local possui condições adequadas para suportar o produto.

- 1 - Posicione o armário na parede e alinhe-o utilizando um nível
- 2 - Fure a parede com a broca de 8mm através do furo da cantoneira
- 3 - Insira o conjunto de parafuso e bucha no furo e aperte até o final para travar

SECURING TO WALL (MASONRY)

ATTENTION: Before securing the cabinet to the wall, check whether the location has suitable conditions to support the product.

- 1 - Position the cabinet on the wall and align it using a level
- 2 - Drill wall with 8 mm bit through the hole in the corner brace
- 3 - Insert the screw and anchor assembly into the hole and tighten to the end in order to lock into place

FIJACIÓN EN LA PARED (MAMPOSTERÍA)

ATENCIÓN: Antes de fijar el mueble a la pared, compruebe que la ubicación es adecuada y puede soportar el peso del producto.

- 1 - Coloque el armario en la pared y alinéelo con un nivel
- 2 - Taladre la pared con la broca de 8 mm a través del orificio de la cantonera
- 3 - Inserte el conjunto de tornillo y taco en el orificio y apriételo hasta el

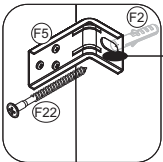

FURAR AQUI / DRILL HERE / PERFORAR

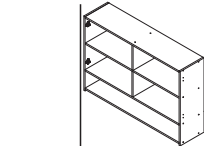

OBS: No final deste manual, verifique sugestões alternativas de instalação do produto em paredes que não sejam de alvenaria (gesso acartonado/drywall)

NOTE: At the end of this manual, see alternative suggestions for installing the product on non-masonry walls (plasterboard/drywall)

OBS: Al final de este manual, consulte las sugerencias alternativas para instalar el producto en paredes que no sean de mampostería (yeso acartonado/pared seca)

PASSO 8

STEP 8

PASO 8

F23 8

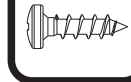

A8 4

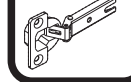

- 1 - Encaixar a dobradiça A8 nas portas e fixá-las com os parafusos F23 (4x14mm)

- 1 - Fit hinge A8 to the doors and secure them with screws F23 (4x14 mm)

- 1 - Coloque la bisagra A8 en las puertas fijelas con los tornillos F23 (4x14 mm)

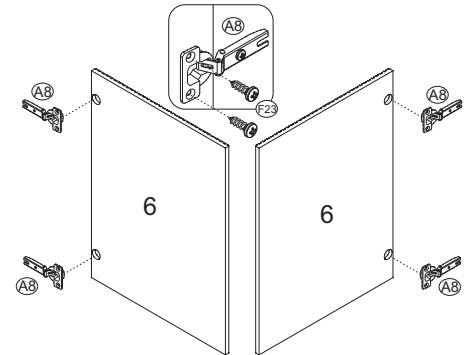

PASSO 9

STEP 9

PASO 9

A8 4

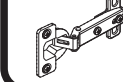

- 1 - Para montar a porta, encaixe a dobradiça no calço travando-a no parafuso indicado com o número 1 abaixo:

- 1 - To assemble the door, fit hinge onto hinge base plate, locking it onto the screw indicated with # 1 below:

- 1 - Para montar la puerta, encaje la bisagra en la cuña, bloqueándola en el tornillo indicado con el número 1 a continuación:

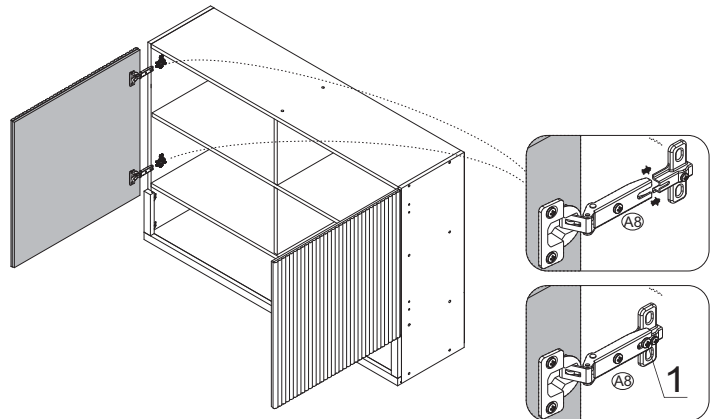

PASSO 10

STEP 10

PASO 10

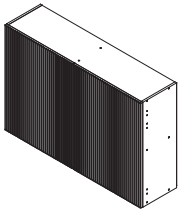

Para regulagem das portas siga as instruções conforme números abaixo:

- 1 - Se precisar subir ou abaixar um pouco a porta desaperte um pouco os parafusos indicados com o número 1, reposicione e aperte novamente
- 2 - Se precisar empurrar a porta um pouco mais para dentro ou puxá-la para fora, desaperte um pouco o parafuso indicado com o nº 2, reposicione e aperte novamente
- 3 - Se precisar alinhar as portas um pouco mais para o centro ou em direção as laterais, utilize uma chave philips para girar o parafuso indicado com o nº 3 até posicionar a porta da forma desejada

To adjust the doors, follow the instructions according to the numbers below:

- 1 - If you need to raise or lower the door a little, loosen the screws indicated with # 1, reposition and tighten again
- 2 - If you need to push the door a little further in or pull it out, loosen the screw indicated by # 2 a little, reposition it and tighten it again
- 3 - If you need to align the doors a little more towards the center or towards the sides, use a Philips screwdriver to turn the screw indicated by # 3 until you position the door as desired.

Para ajustar las puertas, siga las instrucciones de las figuras siguientes:

- 1 - Si necesita subir o bajar un poco la puerta, afloje los tornillos indicados con el número 1, vuelva a colocarlos y apriételes de nuevo
- 2 - Si necesita empujar la puerta un poco más hacia dentro o afuera, afloje un poco el tornillo indicado con el número 2, vuelva a colocarlo y apriétele de nuevo
- 3 - Si necesita alinear las puertas un poco más hacia el centro o hacia los lados, utilice un destornillador philips para girar el tornillo indicado con el número 3 hasta que la puerta quede colocada de la forma deseada

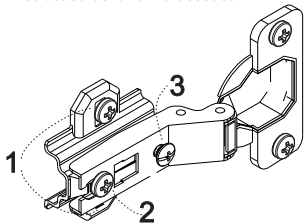

PASSO 11

STEP 11

PASO 11



Para fazer o acabamento dos módulos siga os passos abaixo:

- 1 - Cole o tapa furo adesivo F34 (12mm) sobre todos os parafusos aparentes
- 2 - Encaixe a tampa plástica F6 sobre todas as cantoneiras metálicas
- 3 - Cole os batentes de silicone F33 nos cantos inferiores e superiores de todas as portas

To finish the modules, follow the steps below:

- 1 - Stick adhesive hole covers F 34(12 mm) over all visible screws
- 2 - Fit plastic covers F6 over all metal corners
- 3 - Stick silicone bumpers F33 to the bottom and top corners of all doors

Para terminar el armado de los módulos, siga los pasos que se indican a continuación:

- 1 - Pegue el cubre orificio adhesivo F34 (12 mm) sobre todos los tornillos a la vista
- 2 - Coloque la cubierta de plástico F6 sobre todas las cantoneiras metálicas
- 3 - Pegue los topes de silicona F33 en las esquinas inferior y superior de todas las puertas

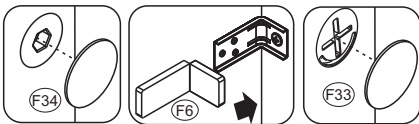

ATENÇÃO: Caro(a) cliente, na ferragem desse produto contém componentes para instalação do móvel em parede de alvenaria. Para fixação do armário em paredes de gesso acartonado/drywall, é necessário adquirir, em uma loja de material de construção, a ferragem específica para esses tipos de parede.

ATTENTION: Dear customer, the hardware of this product contains components for installing the unit on a masonry wall. To secure the cabinet to plasterboard/drywall walls, it is necessary to purchase specific hardware for these types of walls at a hardware store.

ATENCIÓN: Estimado cliente, los herrajes de este producto contienen componentes para instalar el mueble en un muro de mampostería. Para fijar el armario a las paredes de yeso acartonado/pared seca, tendrá que comprar los herrajes específicos para este tipo de paredes en una tienda de materiales de construcción

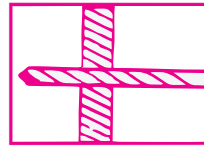

1 - Fure a parede de acordo com o diâmetro da bucha

1 - Drill the wall according to the anchor diameter

1 - Taladre la pared en función

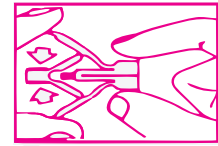

2 - Comprima as asas da bucha antes de introduzi-la

2 - Compress the wings of the anchor before inserting it

2 - Comprima las alas del taco antes de insertarlo

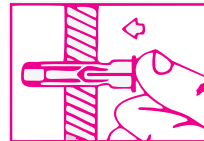

3 - Introduza a bucha no furo da parede

3 - Insert the anchor into the hole in the wall

3 - Inserte el taco en el agujero de la pared

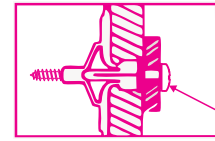

Aperte o parafuso até a fixação estar segura

Tighten the screw until securely affixed

Apriete el tornillo hasta que la fijación quede firme

4 - Posicione o armário com a cantoneira sobre a bucha e fixe-o com um parafuso

4 - Position the cabinet with the corner brace over the anchor and secure it with a screw

4 - Coloque el armario con la cantonera sobre el taco y fijela con un tornillo

OPÇÃO 1 - FIXAÇÃO GESSO/DRYWALL - BUCHA FLY
OPTION 1 - SECURING ON PLASTERBOARD/DRYWALL - WINGED ANCHOR
OPCIÓN 1 - FIJACIÓN EN YESO/PARED SECA - TACO CON ALAS

ATENÇÃO: Caro(a) cliente, na ferragem desse produto contém componentes para instalação do móvel em parede de alvenaria. Para fixação do armário em paredes de gesso acartonado/drywall, é necessário adquirir, em uma loja de material de construção, a ferragem específica para esses tipos de parede

ATTENTION: Dear customer, the hardware of this product contains components for installing the unit on a masonry wall. To secure the cabinet to plasterboard/drywall walls, it is necessary to purchase specific hardware for these types of walls at a hardware store.

ATENCIÓN: Estimado cliente, los herrajes de este producto contienen componentes para instalar el mueble en un muro de mampostería. Para fijar el armario a las paredes de yeso acartonado/pared seca, tendrá que comprar los herrajes específicos para este tipo de paredes en una tienda de materiales de construcción

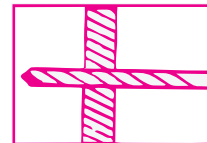

1 - Fure a parede de acordo com o diâmetro da bucha

1 - Drill the wall according to the diameter of the anchor

1 - Taladre la pared en función del diámetro del taco

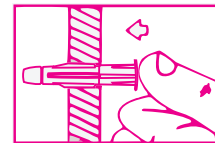

2 - Introduza a bucha no furo da parede

2 - Insert the anchor into the hole in the wall

2 - Inserte el taco en el agujero de la pared

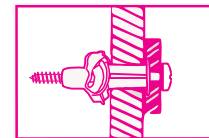

3 - Posicione o armário com a cantoneira sobre a bucha e fixe-o com um parafuso. Aperte o parafuso até a fixação estar segura

3 - Position the cabinet with the corner brace over the anchor and secure it with a screw. Tighten the screw until securely affixed

3 - Coloque el armario con la cantonera sobre el taco y fijela con un tornillo. Apriete el tornillo hasta que la fijación quede firme

OPÇÃO 2 - FIXAÇÃO GESSO/DRYWALL - BUCHA MU
OPTION 2 - SECURING ON PLASTERBOARD/DRYWALL - M.U. ANCHOR
OPCIÓN 2 - FIJACIÓN EN YESO/PARED SECA - TACO MU



neshher

ARMÁRIO AÉREO 2 PORTAS NESHER SIMONE MENDES 80CM 100% MDF

NESHER SIMONE MENDES WALL CABINET W/ 2 DOORS
80 CM 100% MDF /

ARMARIO COLGANTE CON 2 PUERTA
NESHER SIMONE MENDES DE 80 CM 100 % MDF



A marca da gestão florestal responsável

The mark of responsible forest management

La marca de la gestión forestal responsable

FSC® C168299

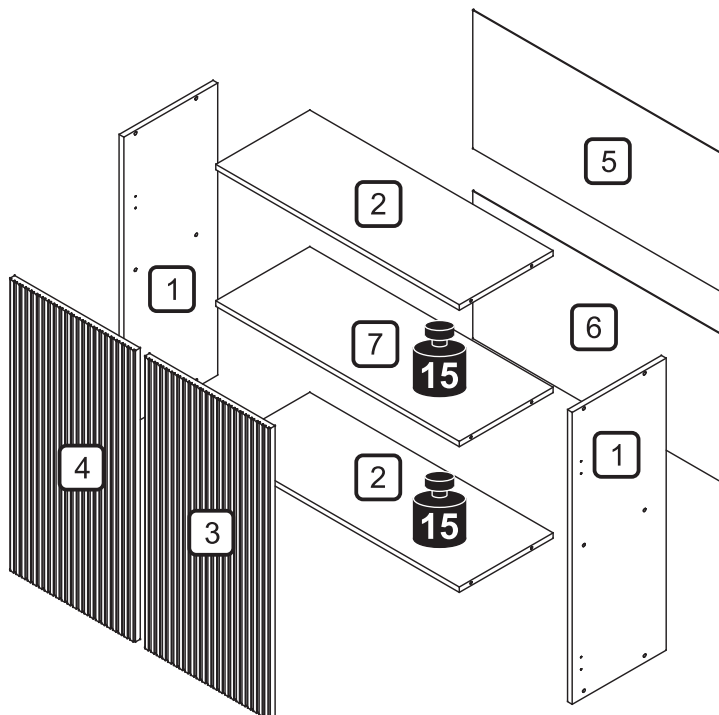
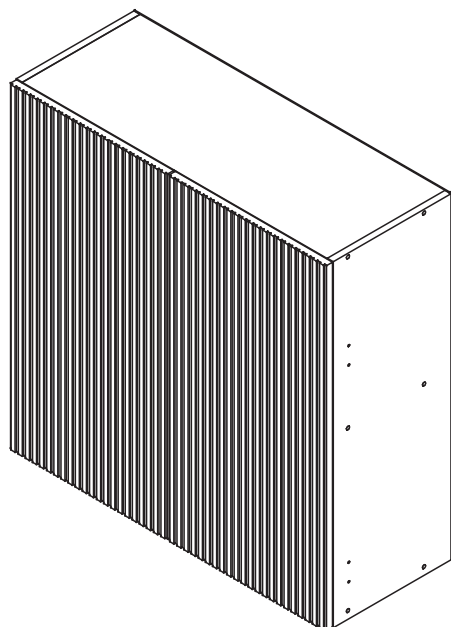

Peso máximo suportado

Maximum weight supported

Peso máximo suportado

DIMENSÕES MÁXIMAS DO PRODUTO MONTADO

MAXIMUM DIMENSIONS OF THE ASSEMBLED PRODUCT

DIMENSIONES MÁXIMAS DEL PRODUCTO MONTADO

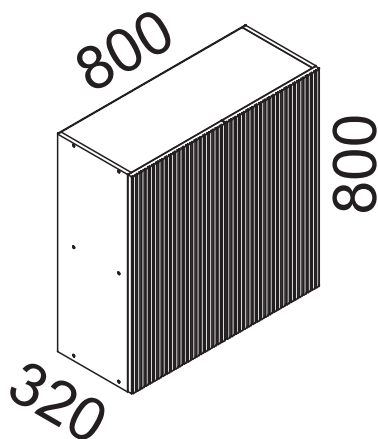





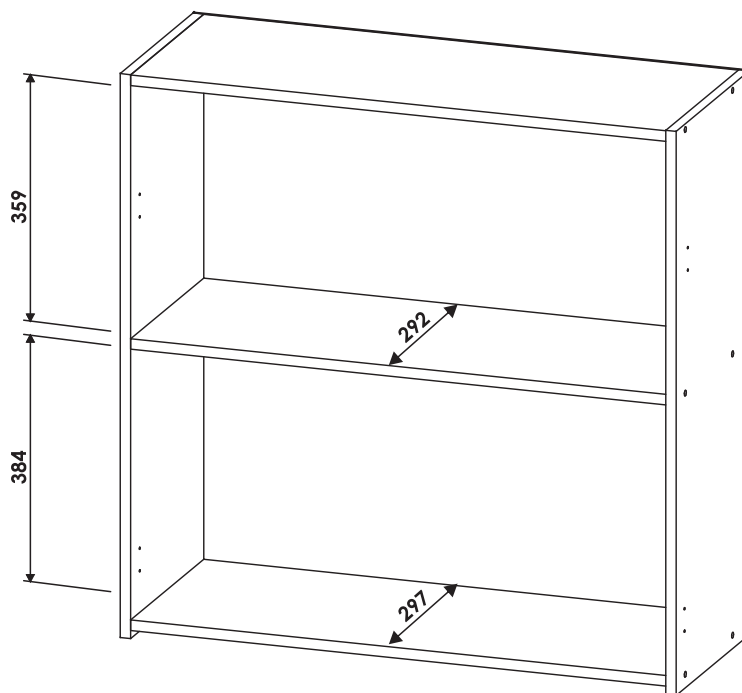

DIMENSÕES DOS ESPAÇOS INTERNOS (MEDIDAS EM MILÍMETROS)

DIMENSIONS OF INTERNAL SPACES (MEASUREMENTS IN MILLIMETERS)

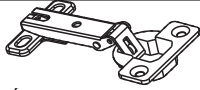
DIMENSIONES DEL ESPACIO INTERNO (MEDIDAS EN MILÍMETROS)

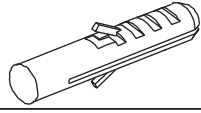

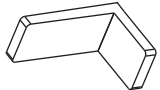
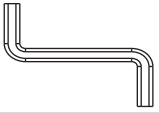
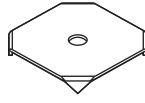
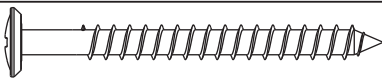
CÓDIGO CODE CÓDIGO	CARVALHO/GREIGE CARVALHO/GREIGE CARVALHO/GREIGE	DESCRIÇÃO DESCRIPTION DESCRIPCIÓN	MAT. PRIMA RAW MATERIAL MATERIA PRIMA	QUANT QTY CANT	MEDIDAS MEASUREMENTS MEDICIONES		
1	403546	LATERAL DIREITA_ESQUERDA / RIGHT_LEFT SIDE / LATERAL DERECHO_IZQUIERDO	MDF	2	800	297	15
2	403503	BASE_TAMPO / BASE_TOP / BASE_TAPA	MDF	2	770	297	15
3	403547	PORTA DIREITA MONTADA / RIGHT DOOR ASSEMBLED / PUERTA DERECHA MONTAJE	MDF	1	770	292	15
4	403536	PORTA ESQUERDA MONTADA / LEFT DOOR ASSEMBLED / PUERTA IZQUIERDA MONTAJE	MDF	1	798	397	18
5	403537	FUNDO TRASEIRO / BACK PANEL / FONDO POSTERIOR	DURATREE	1	798	397	18
6	402853	FUNDO TRASEIRO / BACK PANEL / FONDO POSTERIOR	DURATREE	1	795	379	2.5
7	402854	PRATELEIRA / SHELF / ESTANTE	MDF	1	795	404	2.5

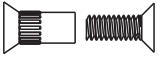
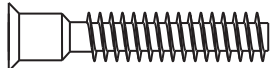
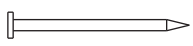
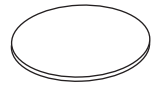
CÓDIGO/DESCRIÇÃO CODE/DESCRIPTION CÓDIGO/DESCRIPCIÓN	QUANTIDADE QUANTITY CANTIDAD	CÓDIGO/DESCRIÇÃO CODE/DESCRIPTION CÓDIGO/DESCRIPCIÓN	QUANTIDADE QUANTITY CANTIDAD
A8 DOBRADIÇA SLOW CI / CALÇO RETA CANECO 35mm - CÓDIGO 200162 35mm STRAIGHT OVERLAY HINGE WITH BASE PLATES - CODE 200162 BISAGRA DE CIERRE LENTO CON CUÑA DE BISAGRA RECTA DE 35mm - CÓDIGO 200162	 4	F1 BATENTE DE SILICONE 12MM SILICONE BUMPER 12MM TOPE DE SILICONA 12MM	 4
F2 BUCHA DE PAREDE PLÁSTICA DE 8mm 8mm PLASTIC WALL ANCHOR TACOS DE PARED PLASTIC DE 8mm	 4	F5 CANTONEIRA METÁLICA PARA FIXAÇÃO NA PAREDE 54x28x28mm 54x28x28mm METAL CORNER BRACE FOR SECURING TO WALL CANTONERA METÁLICA PARA FIJACIÓN EN LA PARED 54x28x28mm	 4
F6 CAPA PLÁSTICA PARA CANTONEIRA 55X30X30mm 55X30X30mm PLASTIC COVER FOR CORNER BRACE TAPA DE PLÁSTICO PARA ÂNGULO 55X30X30mm	 4 NATURE NATURE NATURE	F9 CHAVE ZETA 4mm 4mm S-SHAPED HEX KEY LLAVE ZETA 4mm	 1
F11 FIXADOR TRASEIRO METÁLICO 14x14mm 14x14mm METAL BACK PANEL FASTENER SUJETADOR METÁLICO DEL FONDO POSTERIOR 14x14mm	 6	F22 PARAFUSO PHILIPS 5x50mm CABEÇA FLANGEADA PHILIPS SCREW 5x50 mm FLANG HEAD TORNILLO PHILIPS 5x50 mm CABEZA CON BRIDA	 4
F23 PARAFUSO PHILIPS 4x14mm CABEÇA PANELA PHILIPS SCREW 4x14 mm PAN HEAD TORNILLO PHILIPS 4x14 mm CABEZA ALOMADA	 20	F25 PARAFUSO UNIÃO 28mm 28mm CONNECTOR SCREW TORNILLO DE UNIÃO 28mm	 3
F26 PARAFUSO UNIÃO 17mm 17mm CONNECTOR SCREW TORNILLO DE UNIÃO 17mm	 9	F28 PARAFUSO ALLEN S_PONTA 7x40mm CABEÇA CHATA ALLEN SCREW WITOUH TIP 7x40 mm FLAT HEAD TORNILLO ALLEN SIN PUNTA 7x40 mm CABEZA PLANA	 12
F29 PREGO 10X10 COM CABEÇA 10x10 NAIL WITH HEAD CLAVO CON CABEZA DE 10x10	 40	F34 TAPA FURO ADESIVO 12mm 12mm ADHESIVE HOLE COVERS CUBRE ORIFICIOS ADHESIVO DE 12mm	 20 NATURE NATURE NATURE

Ferramentas para montagem e instalação / Tools for assembly and installation / Herramientas de montaje e instalación
Não fornecidas / Not Provided / No Provisto



PARAFUSADEIRA
POWER SCREWDRIVER
DESTORNILLADOR



FURADEIRA
DRILL
TALADRO



NÍVEL
LEVEL
NIVEL



TRENA
TAPE MEASURE
CINTA METRICA



MARTELO
HAMMER
MARTILLO



CHAVE PHILIPS E FENDA
PHILLIPS SCREWDRIVER
LLAVE PHILIPS



MONTAGEM
ASSEMBLY
MONTAJE

PASSO 1

STEP 1

PASO 1

- 1 - Posicione as cantoneiras F5 na borda traseira das peças 1 e fixe-as com os parafusos F23 (4x14mm)
- 2 - Fixar os calços das dobradiças A8 com parafuso de união F26 17MM

- 1 - Position corner braces F5 on the back edge of parts 1 and secure them with screws F23 (4x14 mm)
- 2 - Secure hinge base plates A8 with connector screw F26 17MM

- 1 - Coloque las cantoneras F5 en el borde posterior de las piezas 1 y fíjelas con los tornillos F23 (4x14 mm)
- 2 - Fije las cuñas de las bisagras A8 con el tornillo de unión F26 17 mm

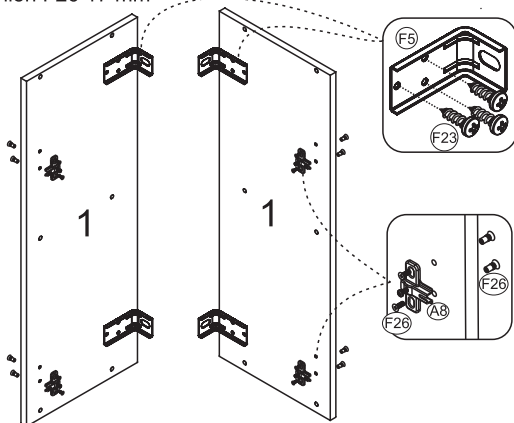
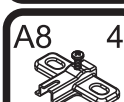
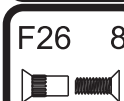
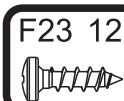

PASSO 4

STEP 4

PASO 4

FIXAÇÃO NA PAREDE (ALVENARIA)

ATENÇÃO: Antes de fixar o armário na parede verifique se o local possui condições adequadas para suportar o produto.

- 1 - Posicione o armário na parede e alinhe-o utilizando um nível
- 2 - Fure a parede com a broca de 8mm através do furo da cantoneira
- 3 - Insira o conjunto de parafuso e bucha no furo e aperte até o final para travar

SECURING TO WALL (MASONRY)

ATTENTION: Before securing the cabinet to the wall, check whether the location has suitable conditions to support the product.

- 1 - Position the cabinet on the wall and align it using a level
- 2 - Drill wall with 8 mm bit through the hole in the corner brace

- 3 - Insert the screw and anchor assembly into the hole and tighten to the end in order to lock into place

FIJACIÓN EN LA PARED (MAMPOSTERÍA)

ATENCIÓN: Antes de fijar el mueble a la pared, compruebe que la ubicación es adecuada y puede soportar el peso del producto.

- 1 - Coloque el armario en la pared y alínelo con un nivel
- 2 - Taladre la pared con la broca de 8 mm a través del orificio de la cantonera

- 3 - Inserte el conjunto de tornillo y taco en el orificio y apriételo hasta el

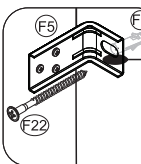

FURAR AQUI / DRILL HERE / PERFORAR

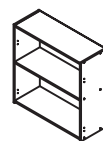

PASSO 2

STEP 2

PASO 2

- 1 - Fixar as peças 1 nas peças 2 e 7 com os parafusos F28 (7x40mm), utilizando a chave zeta F9

- 1 - Secure sides 1 to parts 2 and 7 with screws F28 (7x40 mm), using S-shaped hex key F9

- 1 - Fije las piezas 1 a las piezas 2 con tornillos F28 (7x40 mm), utilizando la llave zeta F9

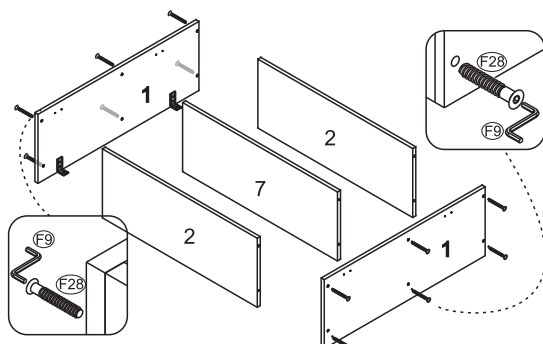
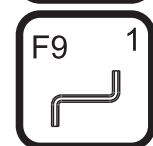
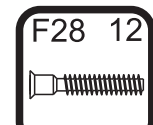

OBS: No final deste manual, verifique sugestões alternativas de instalação do produto em paredes que não sejam de alvenaria (gesso acartonado/drywall)

NOTE: At the end of this manual, see alternative suggestions for installing the product on non-masonry walls (plasterboard/drywall)

OBS: Al final de este manual, consulte las sugerencias alternativas para instalar el producto en paredes que no sean de mampostería (yeso acartonado/pared seca)

PASSO 5

STEP 5

PASO 5

- 1 - Encaixar as dobradiças A8 nas portas, e fixá-las com os parafusos F23 (4x14mm)

- 1 - Fit hinges A8 onto the doors, and secure them with screws F23 (4x14 mm)

- 1 - Coloque las bisagras A8 en las puertas fijelas con los tornillos F23 (4x14 mm)

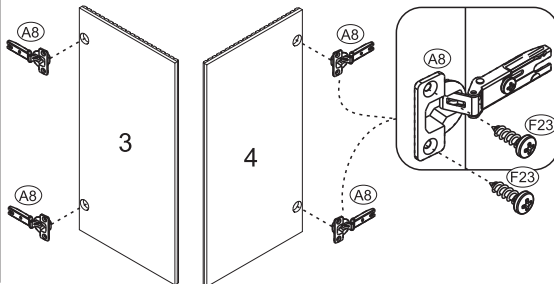
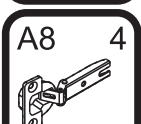
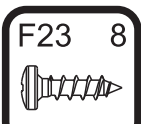

PASSO 3

STEP 3

PASO 3

- 1 - Alinhar a peça 5 e fixá-la com pregos F29 (10x10) na parte de cima e nas laterais

- 2 - Alinhar a peça 6 inferior e fixá-la com pregos F29 (10x10) na parte inferior e laterais

- 3 - Na junção entre as peças 5 e 6 utilizar os pregos F29 (10x10) com o fixador metálico F11

- 1 - Align part 5 and secure it with nails F29 (10x10) on the top and sides

- 2 - Align the lower part 6 and secure it with nails F29 (10x10) on the bottom and sides

- 3 - At the junction between parts 5 and 6, use nails F29 (10x10) with metal fastener F11

- 1 - Alinee la pieza 5 y fíjela con clavos F29 (10x10) en la parte superior y en los laterales

- 2 - Alinee la pieza inferior 6 y fíjela con clavos F29 (10x10) en la parte inferior y en los laterales

- 3 - Al unir las piezas 5 y 6, utilice clavos F29 (10x10) con el sujetador metálico F11

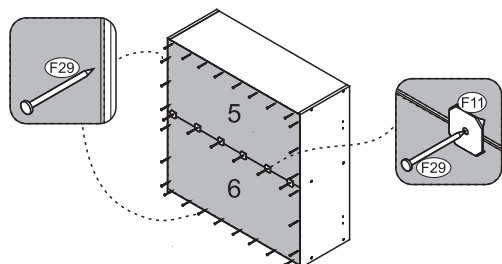
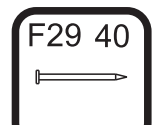

PASSO 6

STEP 6

PASO 6

- 1 - Para montar a porta, encaixe a dobradiça no calço travando-a no parafuso indicado com o número 1 abaixo:

- 1 - To assemble the door, fit hinge onto hinge base plate, locking it onto the screw indicated with # 1 below:

- 1 - Para montar la puerta, encaje la bisagra en la cuña, bloqueándola en el tornillo indicado con el número 1 a continuación:

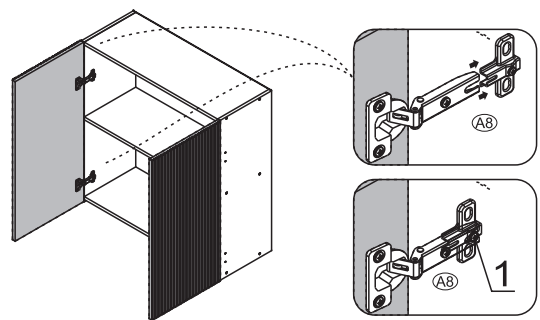
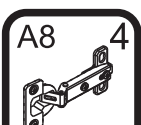

PASSO 7
STEP 7
PASO 7

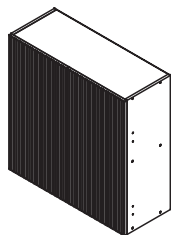

- Para regulagem das portas siga as instruções conforme números abaixo:
- 1 - Se precisar subir ou abaixar um pouco a porta desaperte um pouco os parafusos indicados com o nº 1, reposicione e aperte novamente
 - 2 - Se precisar empurrar a porta um pouco mais para dentro ou puxá-la para fora, desaperte um pouco o parafuso indicado com o nº 2, reposicione e aperte novamente
 - 3 - Se precisar alinhar as portas um pouco mais para o centro ou em direção as laterais, utilize uma chave philips para girar o parafuso indicado com o nº 3 até posicionar a porta da forma desejada

To adjust the doors, follow the instructions according to the numbers below:

- 1 - If you need to raise or lower the door a little, loosen the screws indicated with # 1, reposition and tighten again
- 2 - If you need to push the door a little further in or pull it out, loosen the screw indicated by # 2 a little, reposition it and tighten it again
- 3 - If you need to align the doors a little more towards the center or towards the sides, use a Philips screwdriver to turn the screw indicated by # 3 until you position the door as desired.

Para ajustar las puertas, siga las instrucciones de las figuras siguientes:

- 1 - Si necesita subir o bajar un poco la puerta, afloje los tornillos indicados con el número 1, vuelva a colocarlos y apriételes de nuevo
- 2 - Si necesita empujar la puerta un poco más hacia dentro o afuera, afloje un poco el tornillo indicado con el número 2, vuelva a colocarlo y apriétele de nuevo
- 3 - Si necesita alinear las puertas un poco más hacia el centro o hacia los lados, utilice un destornillador philips para girar el tornillo indicado con el número 3 hasta que la puerta quede colocada de la forma deseada

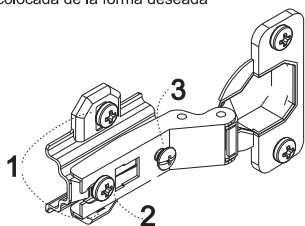

PASSO 8
STEP 8
PASO 8

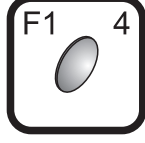

- Para fazer o acabamento dos módulos siga os passos abaixo:
- 1 - Cole o tapa furo adesivo F34 (12mm) sobre todos os parafusos aparentes
 - 2 - Encaixe a tampa plástica F6 sobre todas as cantoneiras metálicas
 - 3 - Cole os batentes de silicone F1 nos cantos inferiores e superiores de todas as portas

To finish the modules, follow the steps below:

- 1 - Stick adhesive hole covers F34(12 mm) over all visible screws
- 2 - Fit plastic covers F6 over all metal corners
- 3 - Stick silicone bumpers F1 to the bottom and top corners of all doors

Para terminar el armado de los módulos, siga los pasos que se indican a continuación:

- 1 - Pegue el cubre orificio adhesivo F34 (12 mm) sobre todos los tornillos a la vista
- 2 - Coloque la cubierta de plástico F6 sobre todas las cantoneiras metálicas
- 3 - Pegue los toques de silicona F1 en las esquinas inferior y superior de todas las puertas

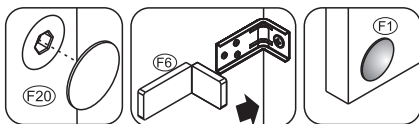

ATENÇÃO: Caro(a) cliente, na ferragem desse produto contém componentes para instalação do móvel em parede de alvenaria. Para fixação do armário em paredes de gesso acartonado/drywall, é necessário adquirir, em uma loja de material de construção, a ferragem específica para esses tipos de parede.

ATTENTION: Dear customer, the hardware of this product contains components for installing the unit on a masonry wall. To secure the cabinet to plasterboard/drywall walls, it is necessary to purchase specific hardware for these types of walls at a hardware store.

ATENCIÓN: Estimado cliente, los herrajes de este producto contienen componentes para instalar el mueble en un muro de mampostería. Para fijar el armario a las paredes de yeso acartonado/pared seca, tendrá que comprar los herrajes específicos para este tipo de paredes en una tienda de materiales de construcción

OPÇÃO 1 - FIXAÇÃO GESSO/DRYWALL - BUCHA FLY
OPTION 1 - SECURING ON PLASTERBOARD/DRYWALL - WINGED ANCHOR
OPCIÓN 1 - FIJACIÓN EN YESO/PARED SECA - TACO CON ALAS

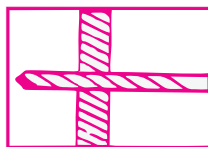

- 1 - Fure a parede de acordo com o diâmetro da bucha
1 - Drill the wall according to the anchor diameter
1 - Taladre la pared en función

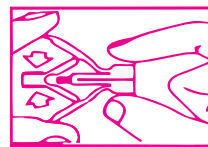

- 2 - Comprima as asas da bucha antes de introduzi-la
2 - Compress the wings of the anchor before inserting it
2 - Comprima las alas del taco antes de insertarlo

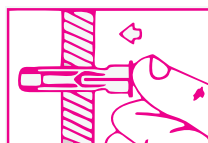

- 3 - Introduza a bucha no furo da parede
3 - Insert the anchor into the hole in the wall
3 - Inserte el taco en el agujero de la pared

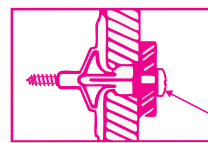

- 4 - Posicione o armário com a cantoneira sobre a bucha e fixe-o com um parafuso
4 - Position the cabinet with the corner brace over the anchor and secure it with a screw
4 - Coloque el armario con la cantonera sobre el taco y fijela con un tornillo

Aperte o parafuso até a fixação estar segura
Tighten the screw until securely affixed
Apriete el tornillo hasta que la fijación quede firme

ATENÇÃO: Caro(a) cliente, na ferragem desse produto contém componentes para instalação do móvel em parede de alvenaria. Para fixação do armário em paredes de gesso acartonado/drywall, é necessário adquirir, em uma loja de material de construção, a ferragem específica para esses tipos de parede

ATTENTION: Dear customer, the hardware of this product contains components for installing the unit on a masonry wall. To secure the cabinet to plasterboard/drywall walls, it is necessary to purchase specific hardware for these types of walls at a hardware store.

ATENCIÓN: Estimado cliente, los herrajes de este producto contienen componentes para instalar el mueble en un muro de mampostería. Para fijar el armario a las paredes de yeso acartonado/pared seca, tendrá que comprar los herrajes específicos para este tipo de paredes en una tienda de materiales de construcción

OPÇÃO 2 - FIXAÇÃO GESSO/DRYWALL - BUCHA MU
OPTION 2 - SECURING ON PLASTERBOARD/DRYWALL - M.U. ANCHOR
OPCIÓN 2 - FIJACIÓN EN YESO/PARED SECA - TACO MU

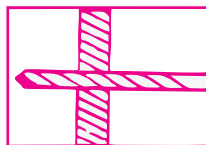

- 1 - Fure a parede de acordo com o diâmetro da bucha
1 - Drill the wall according to the diameter of the anchor
1 - Taladre la pared en función del diámetro del taco

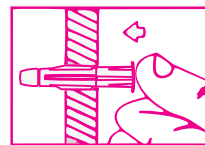

- 2 - Introduza a bucha no furo da parede
2 - Insert the anchor into the hole in the wall
2 - Inserte el taco en el agujero de la pared

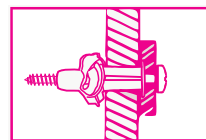

- 3 - Posicione o armário com a cantoneira sobre a bucha e fixe-o com um parafuso. Aperte o parafuso até a fixação estar segura
3 - Position the cabinet with the corner brace over the anchor and secure it with a screw. Tighten the screw until securely affixed
3 - Coloque el armario con la cantonera sobre el taco y fijela con un tornillo. Apriete el tornillo hasta que la fijación quede firme