

ARTESANO

Criador de Ambientes

Dicas de Conservação / Maintenance Tips / Dicas para Conservación

*Para limpar ou tirar manchas, utilize uma flanela umedecida em solução de água e álcool, na mesma proporção.

*Evite exposição ao sol.

*To clean or remove stains, use a piece of flannel dampened with a water and alcohol solution, in the same proportion.

*Avoid direct sunlight.

*Para limpiar o sacar manchas, utilice una flanela humedecida en solución de agua y alcohol, en la misma proporción.

*Evite la exposición directa al sol.

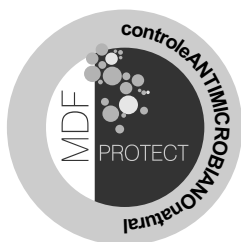

ARTESANO MÓVEIS LTDA.
Estrada da Uva e do Vinho, nº 2347, Bairro São Valentim
Caixa Postal 509 - CEP 95709-210
Bento Gonçalves - RS - Brasil
Fone: +55 54 3458 3400
e-mail: artesano@artesano.com.br

www.artesano.com.br

REF.: 14025/14026/14027/14028

ARTESANO
Criador de Ambientes

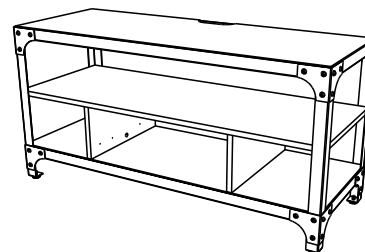

14025

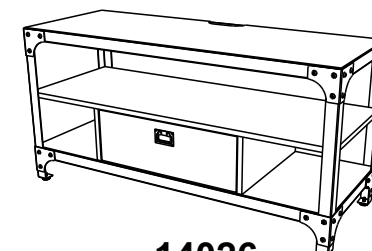

14026

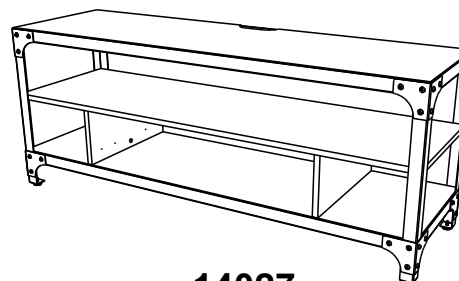

14027

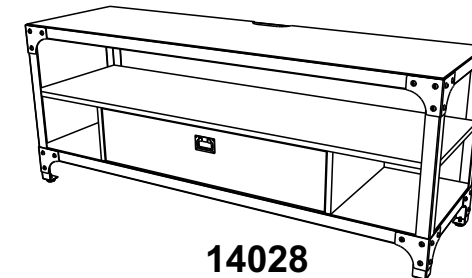

14028

INSTRUÇÕES DE MONTAGEM
ASSEMBLING INSTRUCTIONS / INSTRUCCIONES DE MONTAJE

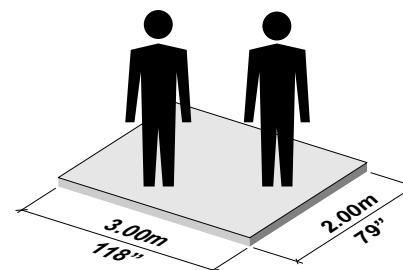



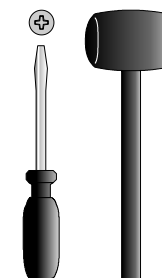





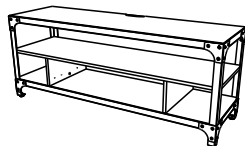

100 min.

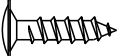
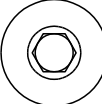
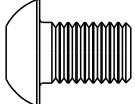

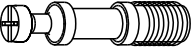
FERRAGENS
HARDWARE LIST
LISTA DE MATERIALES

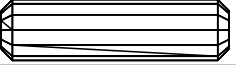
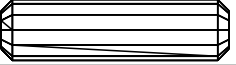



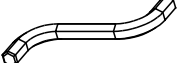
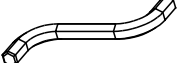







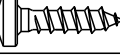



P655/P656



A			3,5 x 14mm	16
B			M8 x12mm	48
C				04
D				04
E			8 x 30mm	12
F			1ª COR Ø18mm	04
G			1/4" x 30	04
H			5mm	01

P657/P658



I			3,0 x 12mm ZINCADO PRETO	04
J			3,5 x 14mm	08
K			4,5 x 45mm	02
L				02
M				02
N			8 x 30mm	08
O			1ª COR Ø18mm	02
P			350mm	02
Q				01

14 Passo
Step
Paso

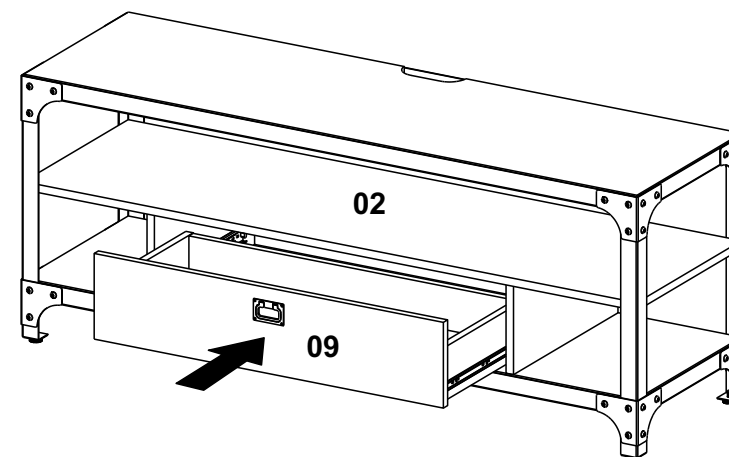

MONTE O MÓVEL COMO NÓS O PRODUZIMOS: COM CARINHO.

ASSEMBLE THE FURNITURE AS WE PRODUCE IT: WITH LOVE.

MONTE EL MUEBLE COMO NOSOTROS LO PRODUCIMOS: CON CARIÑO.

12 Passo
Step
Paso

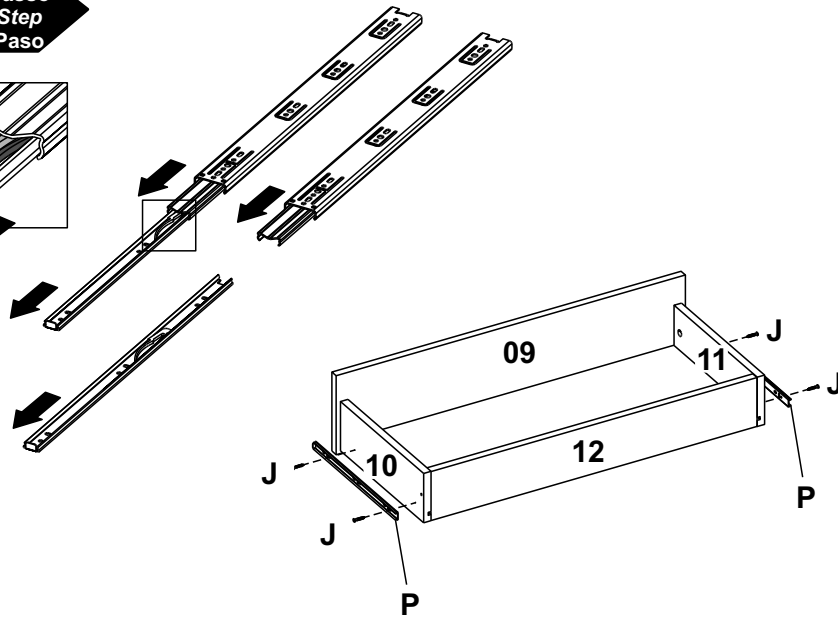
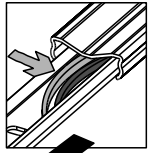

13 Passo
Step
Paso

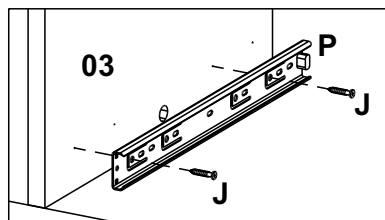
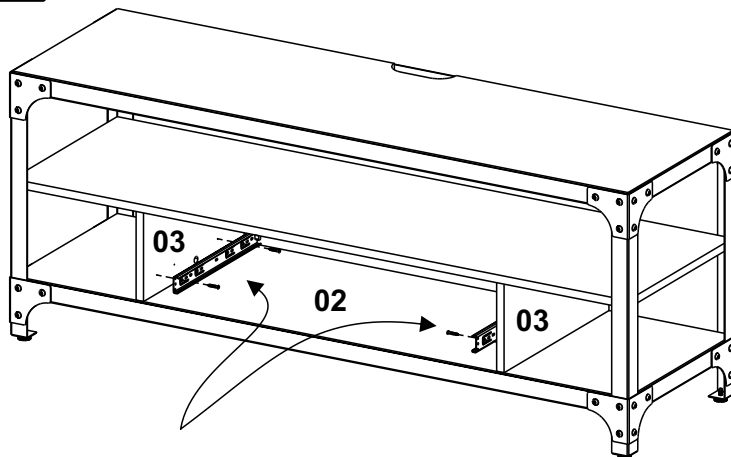

P655/P656

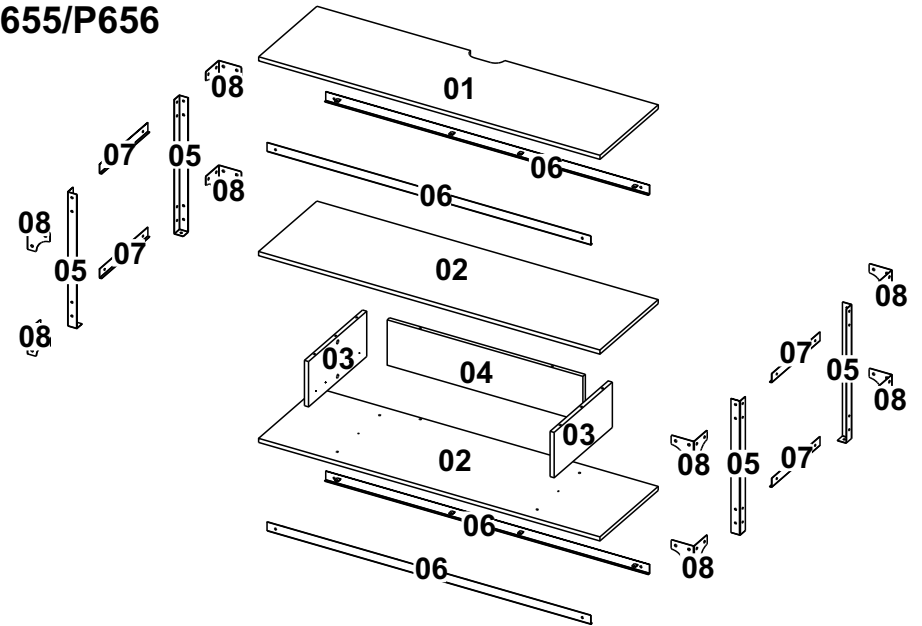

Denominação	Description	Denominación
01 - Tampo	01 - Top	01 - Tapa
02 - Base	02 - Base	02 - Base
03 - Divisão	03 - División	03 - División
04 - Costa	04 - Back	04 - Revés
05 - Perna	05 - Leg	05 - Pierna
06 - Longarina	06 - Stringer	06 - Larguero
07 - Travessa	07 - Crossbar	07 - Travessaño
08 - Cantoneira	08 - Metallic Angle	08 - Rincón

P657/P658

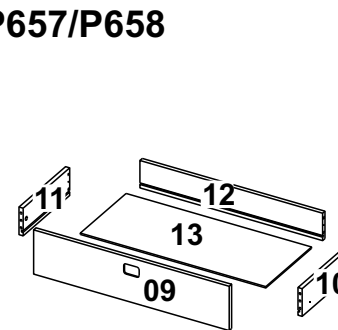

Denominação
09 - Frente Gaveta
10 - Lateral Direita Gaveta
11 - Lateral Esquerda Gaveta
12 - Costa Gaveta
13 - Fundo

Description
09 - Front Drawer
10 - Right Side Drawer
11 - Left Side Drawer
12 - Back Drawer
13 - Bottom Drawer

Denominación
09 - Frente Cajón
10 - Lateral Drecha Cajón
11 - Lateral Izquierda Cajón
12 - Revés Cajón
13 - Fondo Cajón

**ETAPA DE PREPARAÇÃO DAS PEÇAS.
STAGE OF PREPARATION OF THE PIECES.
FASE DE PREPARACIÓN DE LAS PIEZAS.**



PREPARE TODAS AS PEÇAS ANTES DE INICIAR A MONTAGEM.
PREPARE ALL THE PIECES BEFORE BEGINNING THE ASSEMBLY.
PREPARAR TODAS LAS PIEZAS ANTES DE INICIAR EL MONTAJE.

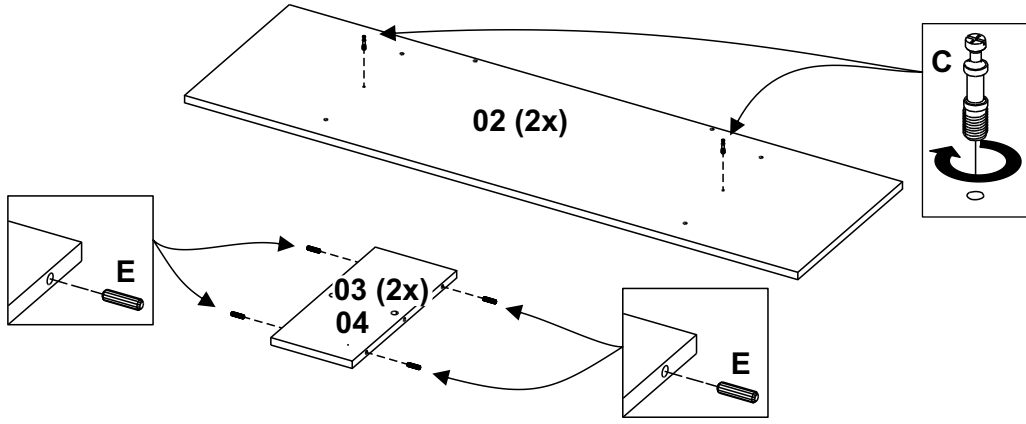

9 Passo
Step
Paso

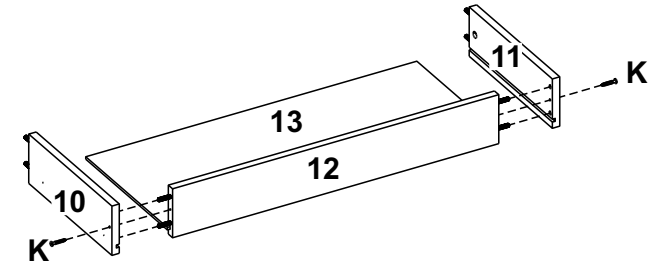

**ETAPA DE MONTAGEM.
STAGE OF ASSEMBLY.
FASE DE MONTAJE.**

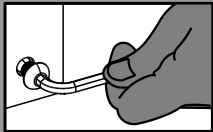

FAZER A MONTAGEM MANUALMENTE COM O USO DA CHAVE ALLEN PARA DAR APERTO AOS PARAFUSOS M8, NÃO UTILIZAR PARAFUSADEIRA.
MAKE HAND ASSEMBLY WITH THE USE OF KEY ALLEN TO GIVE TIGHTENING THE SCREWS M8, DO NOT USE SCREWDRIVER.
HACER EL MONTAJE A MANO CON EL USO DE LLAVE ALLEN PARA APRETAR LOS TORNILLOS M8, NO USE DESTORNILLADOR.

10 Passo
Step
Paso

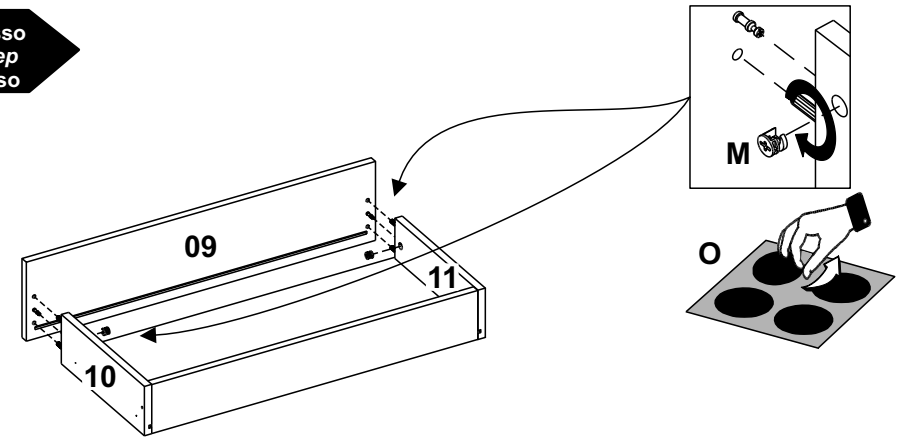

1 Passo
Step
Paso **2x**

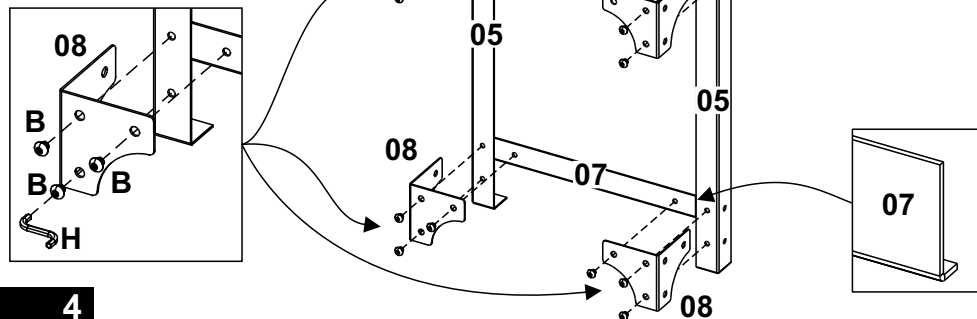

11 Passo
Step
Paso

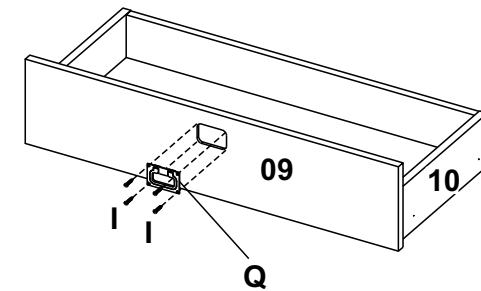

8 Passo
Step
Paso

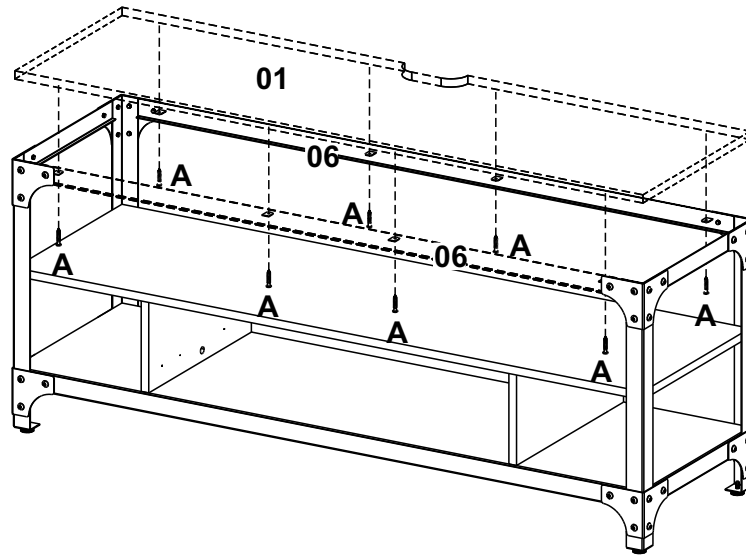

P657/P658

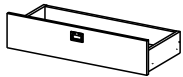

**ETAPA DE PREPARAÇÃO DAS PEÇAS.
STAGE OF PREPARATION OF THE PIECES.
FASE DE PREPARACIÓN DE LAS PIEZAS.**

**PREPARE TODAS AS PEÇAS ANTES DE INICIAR A MONTAGEM.
PREPARE ALL THE PIECES BEFORE BEGINNING THE ASSEMBLY.
PREPARAR TODAS LAS PIEZAS ANTES DE INICIAR EL MONTAJE.**

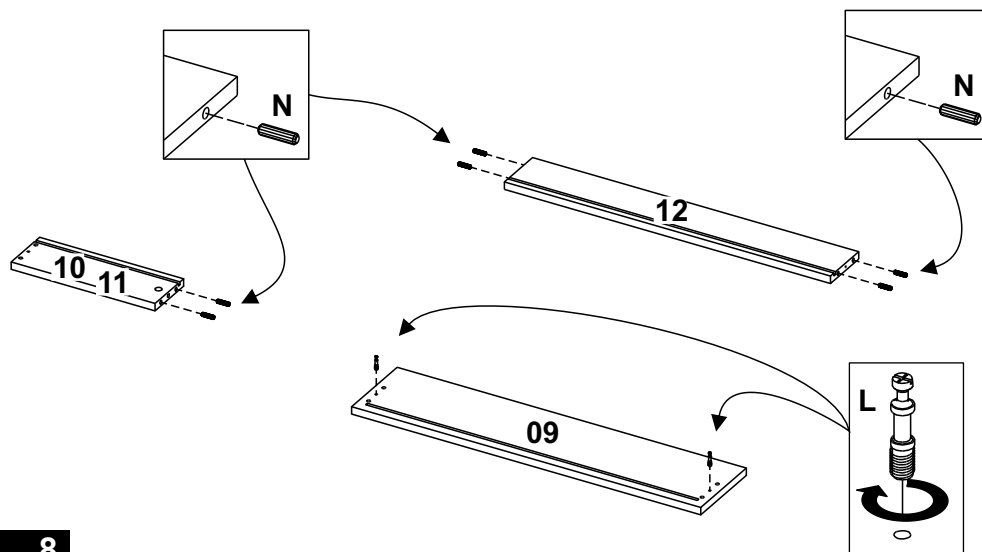

2 Passo
Step
Paso

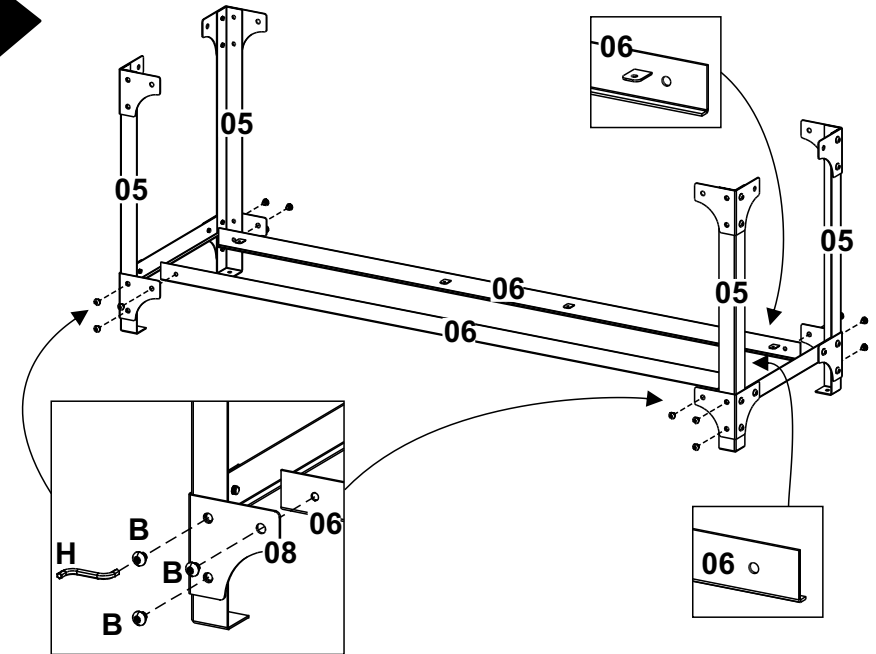

3 Passo
Step
Paso

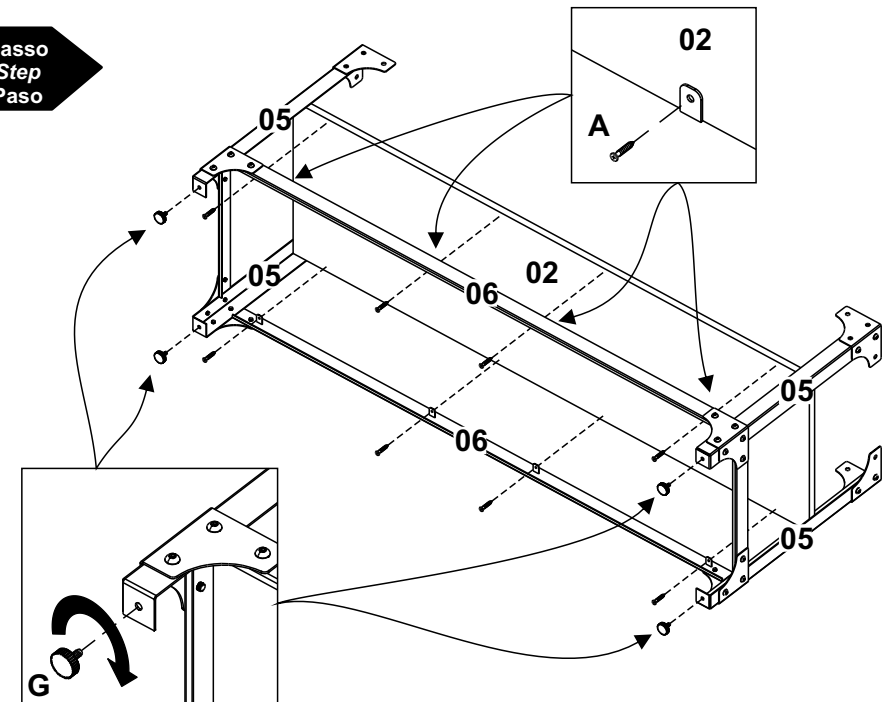

4 Passo
Step
Paso

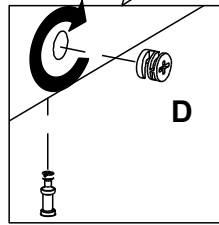
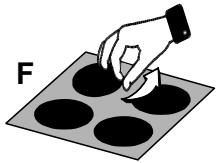
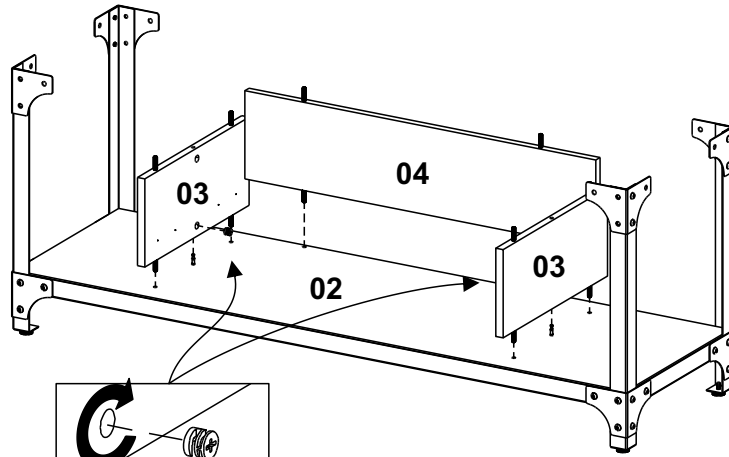

5 Passo
Step
Paso

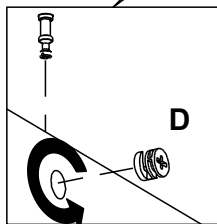
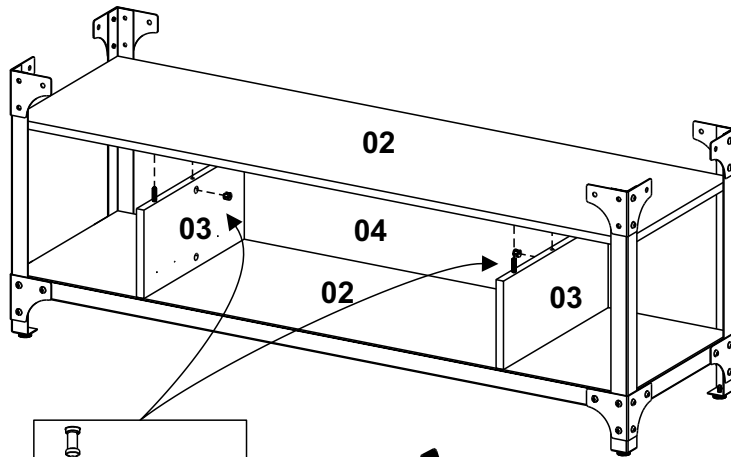

6 Passo
Step
Paso

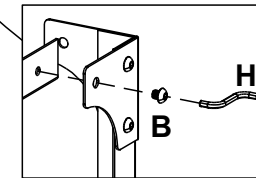
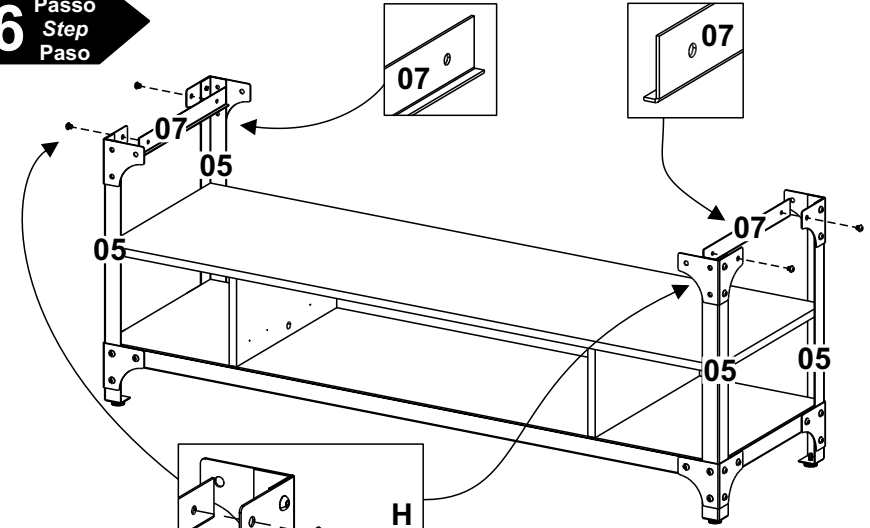

7 Passo
Step
Paso

